

Product Overview

LOW VOLTAGE SWITCHGEAR

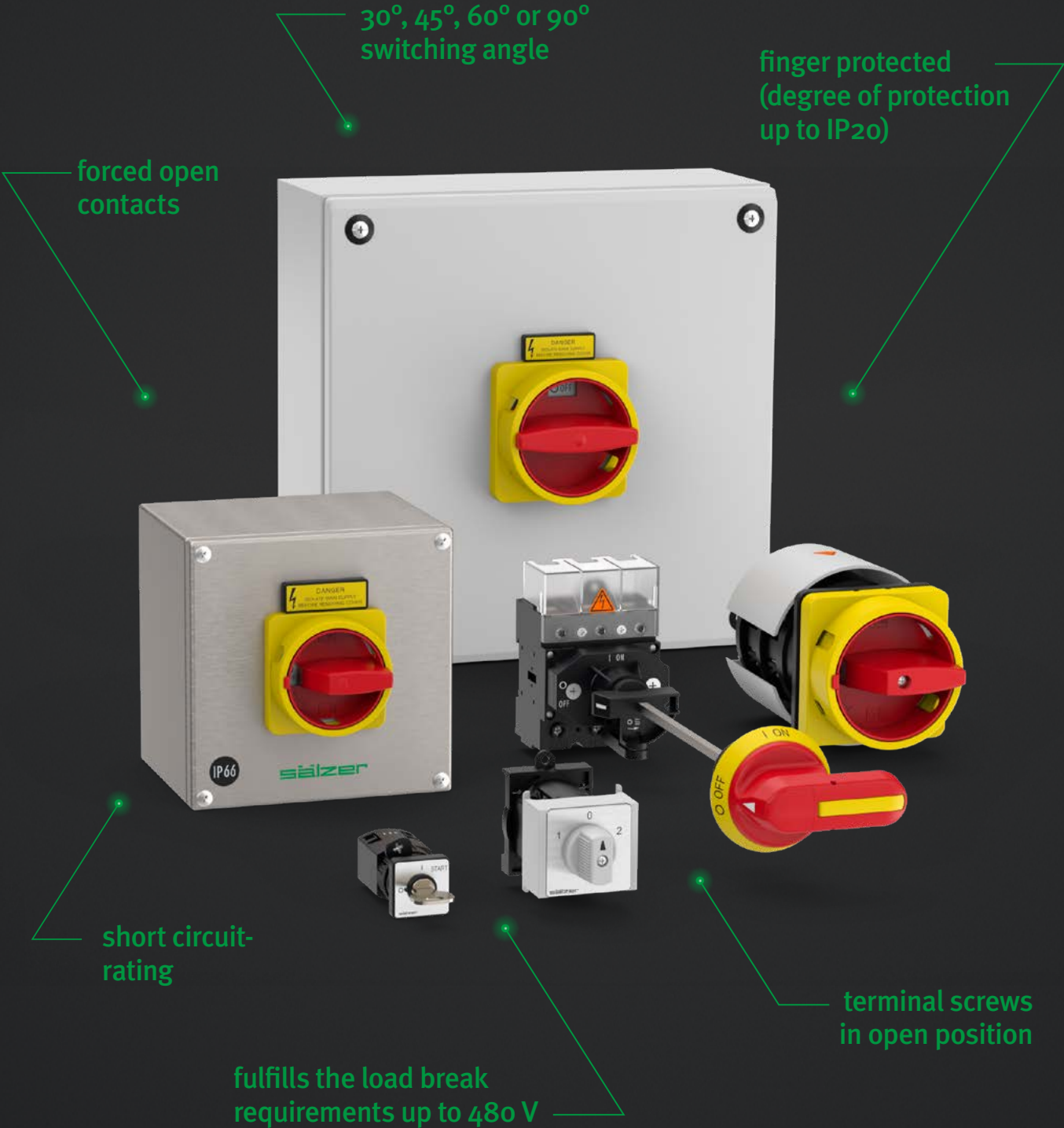



Innovation. Technology. Quality.

Switchgear from Sälzer: Solutions for the future!
Since 1956 Sälzer has specialised in the development, manufacture and sale of low voltage switchgear.

The large selection of types, switching programmes and mounting forms mean that practical reliable solutions can be achieved quickly. Whatever the switch, all individual parts are optimally co-ordinated, easy to assemble and combine.

Whether in switching and automation systems, mechanical engineering and construction, in the heating, climatic and ventilation industry, environmental technology or other areas: Sälzer switches provide safety!

Product support, training and service as well as a Certified Quality Management to DIN EN ISO 9001 are an essential part of our daily work. Our switches comply with national and international standards (IEC / cUL) and are suitable for world-wide application.

Special requirements?

Call us, we'll help you find an individual solution for your switching needs. Our project engineers are here to understand the special requirements of your project and assist to develop a solution as a partner.

Should your requirements not be covered by our extensive standard product range we have our own Design and Development Department for special switches in order to flexibly, promptly and cost effectively meet your individual requirements.

sälzer

Disconnect Switches

Safe Switching and Disconnecting



Rotary Cam Switches

Safe Switching and Controlling



SMD – Sälzer Modular Design

Faster delivery by SMD!

The SMD (Sälzer Modular Design) is based on a modular product idea so that very high flexibility in product options is possible.

SMD modules are individually prefabricated and tested complete modules. By combining these basic elements, different switch configurations can be realised within short time spans. The switches required by you, the customer, are available for despatch following the assembly of the basic switch module to the mounting form and operator modules (SMD Service).

Within 24 hours, the solution matched to your requirements is ready for despatch – worldwide.



Disconnect Switches

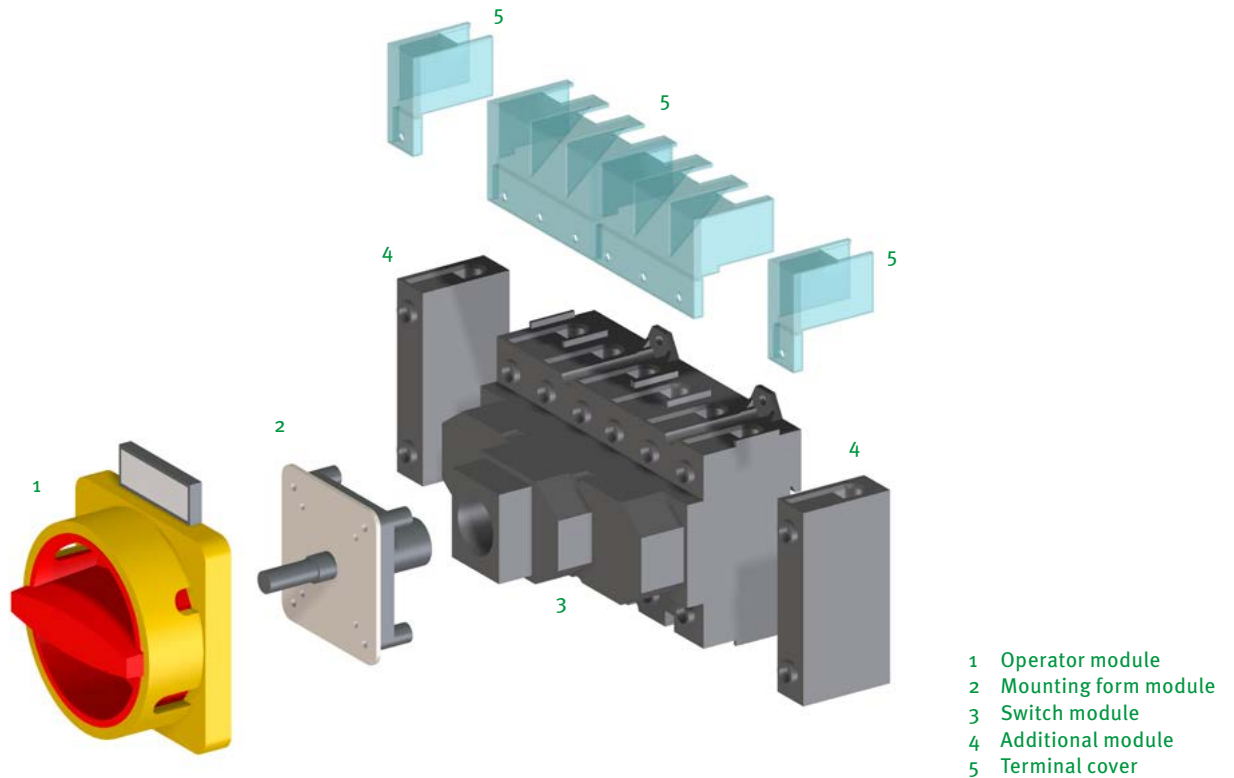

Disconnect Switches

Safe Switching and Disconnecting

Disconnect Switches from Sälzer Electric are hand-operated switchgear for main circuits with 90° switching angle and are offered as ON-OFF Switches (2, 3, 4, 6 and 8 pole) or as Changeover Switches with centre OFF (2, 3 and 4 pole).

Design and Function

- 90° switching angle
- forced open contacts
- finger protected (degree of protection up to IP20)
- short-circuit rating
- fulfills the load break requirements up to 690 V and 1000 V
- terminal screws in open position

Applications

Disconnect Switches offer ideal features for their use as:

- ON-OFF Switches
- Main Switches
- Emergency-Off Switches
- Maintenance Switches
- Safety Switches
- Distribution Switches
- Motor Switches

Conformity

Our products are designed, manufactured and tested according to the following standards:

- IEC 60947
- IEC 60204-1
- EN 60947
- EN 60204-1
- cUL 508

Mounting options:



Front Mounting

- Four hole mounting
- Single hole mounting



Base Mounting

- Snap-on mounting (DIN rail 35 mm DIN EN 60715)
- Four hole mounting



Enclosed Switches

- Insulated enclosure
- Mild steel enclosure
- Stainless steel enclosure

With a broad range of mounting and operator options, Sälzer Electric can provide economical, versatile and reliable solutions!

All products are available in different versions

Disconnect Switches

Rated data

Rated data	H216	H220	H226	H233	B240	B250	B263	H406	H408	H410	H412	K616	K830	
Operational voltage U_e (V AC)	690	690	690	690	690	690	690	690 ¹	690 ¹	690 ¹	690 ¹	690	690	
Impulse withstand voltage U_{imp} (kV)	6	6	6	6	6	6	6	8	8	8	8	6	6	
Overtoltage category	III	III	III	III	III	III	III	III	III	III	III	III	III	
Pollution degree	3	3	3	3	3	3	3	3	3	3	3	3	3	
Uninterrupted current $I_u / I_{th} / I_{the}$ (A)	20	25	32	40	40	50	63	63	80	100	125	160	315	
Load capacity in intermittent operation (class 12) (AB)	DF: 60% = $1.3 \times I_e$ / 40% = $1.6 \times I_e$ / 25% = $2 \times I_e$													
Breaking capacity	220–240V (A)	150	250	300	330	340	340	340	500	550	600	800	900	1800
	380–440V (A)	150	250	300	330	340	340	340	500	550	600	750	850	1650
	500–690V (A)	100	150	190	220	200	200	200	270	285	300	320	340	350
Short-circuit rating (max. fuse) (gL)	20	25	35	40	40	50	63	63	80	100	125	160	315	
Conditional short-circuit current (kA_{eff})	15	15	15	15	—	—	—	25	25	25	25	25	—	
Short-circuit making capacity I_{cm} (kA)	—	—	—	—	1.4	1.6	1.8	—	—	—	—	—	10	
Short-time withstand current (1 s) (A)	—	—	—	—	500	600	750	—	—	—	—	—	4200	
UL Short-circuit 600 V ac, 3 phase (kA)	—	—	—	—	—	—	—	—	—	—	—	—	10	
Isolating characteristics (to EN 60947) (up to ... V AC)	690	690	690	690	690	690	690	1000	1000	1000	1000	690	690	
Switching angle	90°	90°	90°	90°	90°	90°	90°	90°	90°	90°	90°	90°	90°	
Contacts (Current paths) (max.)	8	8	8	8	8	8	8	8	8	8	8	8	8	
Current heat loss per contact at I_u (W)	0.8	0.8	1.8	2.1	2.0	2.4	3.0	3.0	4.1	5.5	6.9	11	28.5	
Terminal capacity (ON-OFF Switches)														
solid or stranded	min. (mm ²)	1	1	1	1	6	6	6	4	4	4	4	95 ²	185 ²
max. (mm ²)		10	10	10	10	25	25	25	50	50	50	50	95 ²	185 ²
flexible or multiwire (including ferrule)	min. (mm ²)	0.75	0.75	0.75	0.75	4	4	4	2.5	2.5	2.5	2.5	95 ²	185 ²
max. (mm ²)		6	6	6	6	16	16	16	35	35	35	35	95 ²	185 ²
American Wire Gauge (ON-OFF Switches) (AWG)		8	8	8	8	4	4	4	1/0	1/0	1/0	1/0	4/0	350MCM
Terminal capacity (Changeover Switches with jumper)														
solid or stranded	min. (mm ²)	1	1	1	1	6	6	6	4	4	4	4	95 ²	185 ²
max. (mm ²)		6	6	6	6	16	16	16	35	35	35	35	95 ²	185 ²
flexible or multiwire (including ferrule)	min. (mm ²)	0.75	0.75	0.75	0.75	4	4	4	2.5	2.5	2.5	2.5	95 ²	185 ²
max. (mm ²)		4	4	4	4	10	10	10	25	25	25	25	95 ²	185 ²
American Wire Gauge (Changeover Switches with jumper) (AWG)		10	10	10	10	6	6	6	2	2	2	2	4/0	350MCM
Thread dimensions for terminal screw		M4	M4	M4	M4	M4	M4	M4	M5	M5	M5	M5	M10	M12
Terminal tightening torque	min. (Nm)	1.2	1.2	1.2	1.2	1.2	1.2	1.2	3.0	3.0	3.0	3.0	10	14
	max. (Nm)	2.5	2.5	2.5	2.5	1.8	1.8	1.8	5.0	5.0	5.0	5.0	20	25
Operational current I_e														
AC-21A (A)		20	25	32	40	40	50	63	63	80	100	125	160	315
AC-22A	220–500V (A)	20	25	32	40	40	50	63	63	80	100	125	160	315
	660–690V (A)	16	20	32	40	40	50	63	63	80	100	100	125	125
AC-23A ($\cos \phi = 0.65$)	400V (A)	12	16	24	32	32	38	47	47	65	80	97	120	231
cUL General Use	300V AC (A)	20	25	30	40	40	50	60	63	80	100	125	175	—
	600V AC (A)	20	25	30	40	40	50	60	63	80	100	125	175	310
Operational power 50–60 Hz (3 phase)														
AC-23A	220–240V (kW)	3	4	5.5	7.5	7.5	11	15	18.5	22	30	37	90	
	380–440V (kW)	5.5	7.5	11	15	15	18.5	22	22	30	37	45	132	
	500V (kW)	5.5	7.5	11	15	18.5	18.5	22	22	30	37	45	—	
	660–690V (kW)	5.5	7.5	11	15	15	18.5	22	22	30	37	45	55	
AC-3	220–240V (kW)	2.2	3	4	5.5	7.5	7.5	11	11	15	22	30	22	37
	380–440V (kW)	3.7	5.5	7.5	11	11	15	18.5	18.5	22	30	37	45	55
	500V (kW)	3.7	5.5	7.5	11	15	15	18.5	18.5	30	37	45	45	—
	660–690V (kW)	3.7	5.5	7.5	11	11	15	18.5	18.5	22	30	37	45	55
	110–120VAC (HP)	1	1.5	2	3	3	5	5	5	7.5	10	15	15	40
	208V AC (HP)	2	3	5	7.5	—	—	—	—	10	15	—	15	75
cUL	220–240VAC (HP)	2	3	5	7.5	7.5	10	10	15	20	25	30	15	75
	440–480VAC (HP)	3	5	10	15	15	20	20	30	30	30	60	40	75
	550–600VAC (HP)	5	5	10	15	15	20	20	30	30	30	50	50	60

¹ 1000V, AC-20, no load switching

² with terminal extensions for cable lug connection

Rated data

Rated data (auxiliary contacts)	H216	H220	H226	H233	B240	B250	B263	H406	H408	H410	H412	K616	K830
Operational voltage U_e (V AC)	500	500	500	500	500	500	500	500	500	500	500	500	500
Uninterrupted current $I_u / I_{th} / I_{the}$ (A)	10	10	10	10	16	16	16	16	16	16	16	20	20
Operational current I_e													
AC-21A (A)	10	10	10	10	10	10	10	10	10	10	10	20	20
110–240V (A)	2,5	2,5	2,5	2,5	6	6	6	6	6	6	6	6	6
AC-15 (A)	1,5	1,5	1,5	1,5	4	4	4	4	4	4	4	4	4
380–440V (A)	1,5	1,5	1,5	1,5	4	4	4	4	4	4	4	4	4
500V (A)	1	1	1	1	1,5	1,5	1,5	1,5	1,5	1,5	1,5	2	2
cUL General Use 600V AC (A)	10	10	10	10	10	10	10	10	10	10	10	20	20
Heavy Pilot Duty	A600	A600	A600	A600	A600	A600	A600	A600	A600	A600	A600	A600	A600
short-circuit rating (max. fuse) (gL)	10	10	10	10	16	16	16	16	16	16	16	20	20
Conditional short-circuit current (kA_{eff})	3	3	3	3	3	3	3	3	3	3	3	10	10
Terminal capacity													
flexible or multiwire (including ferrule) min. (mm ²)	1	1	1	1	1	1	1	1	1	1	1	1	1
max. (mm ²)	2,5	2,5	2,5	2,5	2,5	2,5	2,5	2,5	2,5	2,5	2,5	2,5	2,5
American Wire Gauge (AWG)	14	14	14	14	14	14	14	14	14	14	14	12	12

General

General	H216	H220	H226	H233	B240	B250	B263	H406	H408	H410	H412	K616	K830
Standards	IEC 60947 / EN 60947 / IEC 60204 / UL 508 / CSA 22.2, No. 14 / VDE 0660 part 107												
Mechanical lifespan	>10 ⁵	>10 ⁵	>10 ⁵	>10 ⁵	>10 ⁵	>10 ⁵	>10 ⁵	>10 ⁵	>10 ⁵	>10 ⁵	>10 ⁵	>10 ⁵	>10 ⁵
Max. operating frequency / h	50	50	50	50	50	50	50	50	50	50	50	50	50
Climatic resistance (damp heat)	constant to DIN IEC 60068-2-78												
	cyclic to DIN IEC 60068-2-30												
Ambient temperature (min. / max.)	open (°C) –25 / +50												
	enclosed (°C) –25 / +40												
Mounting position	as required												
Mechanical shock resistance (shock duration 20ms) (g)	>25	>25	>25	>25	>25	>25	>25	>25	>25	>25	>25	>10	>10
Rated frequency (Hz)	50 to 60 (other frequencies on request)												

Conformity

Sälzer Electric Disconnect Switches are conform to the regulations of 'Directive 2014/35/EU on the harmonisation of the laws of the Member States relating to the making available on the market of electrical equipment designed for use within certain voltage limits', specified as Low Voltage Directive.

The conformity is proved by the by the complete compliance of the harmonized EN 60947-1, EN 60947-3, EN 60947-5-1, EN 60204-1.

Sälzer Electric products are developed, manufactured and tested according to these standards. The CE marking on all our products prove the conformity to the directives.

Disconnect Switches from Sälzer are approved according to UL 60947. The Disconnect Switches H216, H220, B240, B250, B263, H406, H408, H410 and H412 are suitable for use as a motor disconnect.



Rotary Cam Switches

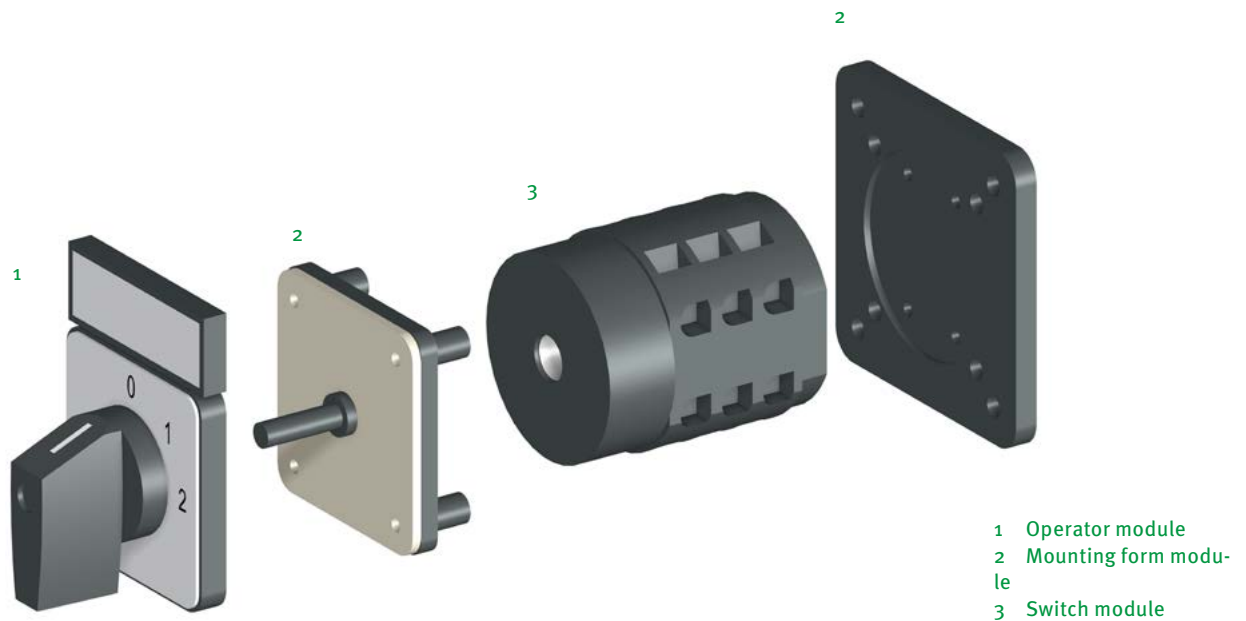

Rotary Cam Switches

Safe Switching and Controlling

Rotary Cam Switches from Sälzer Electric are independently programmable, manually operated control switches for main and auxiliary circuits with up to 24 contacts and are offered with switching angles of 30°, 45°, 60° or 90°. Therefore a maximum of 12 switching positions can be provided.

Design and Function

- 30°, 45°, 60° or 90° switching angle
- forced open contacts
- finger protected (degree of protection up to IP20)
- short-circuit rating
- fulfills the load break requirements up to 480 V
- terminal screws in open position

Applications

Rotary Cam Switches offer ideal features for their use as:

- ON-OFF Switches
- Changeover Switches
- Multi-step Switches
- Code Switches
- Gang Switches
- Instrument Switches
- Motor Switches

Conformity

Our products are designed, manufactured and tested according to the following standards:

- IEC 60947
- IEC 60204-1
- EN 60947
- EN 60204-1
- cUL 508

Mounting options:



Front mounting

- Two hole mounting
- Four hole mounting
- Single hole mounting
- Flush wall mounting



Base mounting

- Snap-on mounting
(DIN rail 35 mm DIN EN 60715)
- Four hole mounting



Enclosed switches

- Insulated enclosure

Our modular technology allows us to build custom switching solutions for up to 24 poles!

All products are available in different versions

Rotary Cam Switches

Rated data

Rated data		P110	M220 P220	M221* P221*	P225	M225 P226*	T225	S432	S440	S606	S608	S612	S825	
Operational voltage U _e	(V AC)	440	690	690	690	690	690	690	690	690	690	690	690	
Impulse withstand voltage U _{imp}	(kV)	4	4	4	6	6	6	6	6	6	6	6	6	
Overvoltage category		III	III	III	III	III	III	III	III	III	III	III	III	
Pollution degree		3	3	3	3	3	3	3	3	3	3	3	3	
Uninterrupted current I _u / I _{th} / I _{the}	(A)	10	20	20	25	25	32	50	63	80	100	160	315	
Load carrying capacity in intermittend operation (class 12)	(AB)	DF: 60% = 1.3 × I _e / 40% = 1.6 × I _e / 25% = 2 × I _e												
Breaking capacity	220–240V	(A)	90	180	180	255	255	370	520	550	600	700	900	1800
	380–440V	(A)	70	150	150	230	230	300	430	500	550	600	850	1650
	500–690V	(A)	—	90	90	270	270	210	280	380	420	450	340	350
short-circuit rating (max. fuse)	(gL)	10	20	20	25	25	32	50	63	80	100	160	315	
Conditional short-circuit current	(kA _{eff})	3	10	10	10	10	15	20	20	25	25	25	—	
Short-circuit making capacity I _{cm}	(kA)	—	—	—	—	—	—	—	—	—	—	—	10	
Short-time withstand current (1 s)	(A)	—	—	—	—	—	—	—	—	—	—	—	4200	
UL Short-circuit 600 V ac, 3 phase	(kA)	—	—	—	—	—	—	—	—	—	—	—	10	
Isolating characteristics (to EN 60947)	(up to ... V AC)	480	480	480	690	690	690	690	690	690	690	690	690	
Switching angle		30° / 45° / 60° / 90°												
Contacts (Current paths) (max.)		16	24	24	24	24	24	24	24	24	24	24	24	
Current heat loss per contact at I _u	(W)	0.3	0.65	0.65	0.75	0.75	1	3	3.5	4	5	11	28.5	
Terminal capacity														
solid or stranded	min.	(mm ²)	0.75	1	1	1.5	1.5	2.5	2.5	4	6	10	10	185 ¹
	max.	(mm ²)	1.5	2.5	2.5	4	4	6	10	16	25	35	70	185 ¹
flexible or multiwire (including ferrule)	min.	(mm ²)	0.75	1	1	1.5	1.5	1.5	2.5	2.5	6	10	10	185 ¹
	max.	(mm ²)	1.5	2.5	2.5	2.5	2.5	4	6	10	16	25	50	185 ¹
American Wire Gauge	(AWG)	16	12	12	10	10	10	6	4	4	1/0	2/0	350MCM	
Thread dimensions for terminal screw		M2.5	M3	M3	M3.5	M3.5	M4	M5	M5	2×M4	2×M5	2×M6	M12	
Terminal tightening torque	min.	(Nm)	0.4	0.5	0.5	0.8	0.8	1.2	2	2	1.2	2	2.5	14
	max.	(Nm)	0.6	1	1	1.5	1.5	2.5	4	4	2.5	4	6	25
Operational current I _e														
AC-21A	220–500V	(A)	10	20	20	25	25	32	50	63	80	100	160	315
	660–690V	(A)	—	20	20	25	25	32	50	60	80	80	125	125
AC-22A	440V	(A)	6	16	16	22	22	30	44	50	65	80	120	231
cUL General Use	300V AC	(A)	10	20	20	25	25	35	55 ¹	70 ¹	95 ¹	110 ¹	175 ¹	—
	600V AC	(A)	—	—	20	—	25	35	55 ¹	70 ¹	95 ¹	110 ¹	175 ¹	310
Operational power 50–60 Hz (3 phase)														
AC-23A	220–240V	(kW)	1.8	4	4	5.5	5.5	7.5	11	15	30	30	37	90
	380–440V	(kW)	3	7.5	7.5	11	11	15	22	30	45	55	75	132
	500V	(kW)	—	7.5	7.5	11	11	15	30	45	55	55	90	—
	660–690V	(kW)	—	7.5	7.5	11	11	15	30	37	45	45	55	55
AC-3	220–240V	(kW)	1.5	3	3	4	4	5.5	11	15	15	22	22	37
	380–440V	(kW)	2.2	5.5	5.5	7.5	7.5	11	22	30	30	37	45	55
	500V	(kW)	—	5.5	5.5	7.5	7.5	11	22	30	30	37	45	—
	660–690V	(kW)	—	5.5	5.5	7.5	7.5	11	22	30	30	37	45	55
cUL	110–120V AC	(HP)	0.5	1	1	1.5	1.5	3	5	7.5	10	10	15	40
	208V AC	(HP)	0.5	2	2	5	5	7.5	7.5	7.5	10	15	15	75
	220–240V AC	(HP)	0.5	2	2	5	5	7.5	10	15	15	15	15	75
	440–480V AC	(HP)	—	—	5	—	10	10	20	30	30	30	40	75
	550–600V AC	(HP)	—	—	5	—	10	10	25	40	50	50	50	60

¹ use this version for 600V AC UL/CSA application

¹ with terminal extensions for cable lug connection

Rated data

Rated data (auxiliary contacts)		P110	M220 P220	M221* P221*	P225	M225 P226*	T225	S432	S440	S606	S608	S612	S825
Operational voltage U_e	(V AC)	440	500	500	500	500	500	500	500	500	500	500	500
Uninterrupted current $I_u / I_{th} / I_{the}$	(A)	10	20	20	25	25	32	50	63	80	100	160	315
Operational current I_e													
AC-21A	(A)	10	20	20	25	25	32	50	63	80	100	160	315
	110–240V (A)	2.5	6	6	6	6	14	16	16	16	16	16	16
AC-15	380–440V (A)	1.5	4	4	5	5	6	7	7	7	7	7	7
	500V (A)	0.8	2	2	2.5	2.5	3	3.5	3.5	3.5	3.5	3.5	3.5
cUL General Use	600V AC (A)	—	—	20	—	25	35	55	70	70	110	175	240
Heavy Pilot Duty		B300	A300	A600	A300	A600	A600	A600	A600	A600	A600	A600	A600
Short-circuit rating (max. fuse)	(gL)	10	20	20	25	25	32	50	63	80	100	160	315
Conditional short-circuit current	(kA_{eff})	3	10	10	10	10	15	20	20	25	25	25	25
Terminal capacity													
flexible or multiwire	min. (mm ²)	0.75	1	1	1.5	1.5	1.5	2.5	2.5	6	10	10	185 ¹
(including ferrule)	max. (mm ²)	2.5	2.5	2.5	2.5	2.5	2.5	2.5	2.5	2.5	2.5	2.5	2.5
American Wire Gauge	(AWG)	16	12	12	10	10	10	6	4	4	1/0	2/0	350MCM

* use this version for 600V AC UL/CSA application ¹ with terminal extensions for cable lug connection

General

General		P110	M220 P220	M221* P221*	P225	M225 P226*	T225	S432	S440	S606	S608	S612	S825
Standards		IEC 60947 / EN 60947 / IEC 60204 / UL 60947-1 / CSA 22.2, No. 14 / VDE 0660 Teil 107											
Mechanical lifespan		≥10 ⁶	≥10 ⁶	≥10 ⁶	≥10 ⁶	≥10 ⁶	≥10 ⁶	≥10 ⁶	≥10 ⁶	≥10 ⁵	≥10 ⁵	≥10 ⁵	≥10 ⁵
Max. operating frequency/h		50	50	50	50	50	50	50	50	50	50	50	50
Climatic resistance	constant	to IEC 60068-2-78											
(damp heat)	cyclic	to IEC 60068-2-30											
Ambient temperature	open (°C)	–25 / +50											
(min. / max.)	enclosed (°C)	–25 / +40											
Mounting position		as required											
Mechanical shock resistance	(g)	≥10	≥10	≥10	≥10	≥10	≥10	≥10	≥10	≥10	≥10	≥10	≥10
(shock duration 20 ms)													
Rated frequency	(Hz)	50 to 60 (other frequencies on request)											

* use this version for 600V AC UL/CSA application

Conformity

Sälzer Electric Rotary Cam Switches are conform to the regulations of 'Directive 2014/35/EU on the harmonisation of the laws of the Member States relating to the making available on the market of electrical equipment designed for use within certain voltage limits', specified as Low Voltage Directive (LVD).

The conformity is proved by the complete compliance of the harmonized european standards EN 60947-1, EN 60947-3, EN 60947-5-1, EN 60204-1. Rotary Cam Switches from Sälzer are approved according to ANSI/UL 60947-1 and ANSI/UL 60947-4-1A.

Sälzer Electric products are developed, manufactured and tested according to the UL, IEC and EN standards. The markings on all our products prove the conformity to the directives.

The latest information concerning the regulatory requirements (LVD, RoHS, REACH) can be found on our website.



Sälzer Electric GmbH
Clemens-Pfau-Platz 27
09306 Rochlitz

Vertriebszentrum:
T: +49 (0) 37 37 / 87 280
sales@salzer.de

www.saelzer.com

Follow
us on 