

Polarwall Ltd

5 Exe Units
Cofton Road
Marsh Barton
Exeter EX2 8QW

Tel: 0845 8382181

e-mail: info@polarwall.co.uk

website: www.polarwall.co.uk



Agrément Certificate

14/5127

Product Sheet 1

POLARWALL FORMWORK SYSTEMS

POLARWALL INSULATING CONCRETE FORMWORK SYSTEM

This Agrément Certificate Product Sheet⁽¹⁾ relates to Polarwall Insulating Concrete Formwork System, a range of formwork and moulded elements for use in the formation of loadbearing and non-loadbearing internal, external and separating walls in residential and commercial buildings of similar occupancy. Height restrictions apply in some cases.

(1) Hereinafter referred to as 'Certificate'.

CERTIFICATION INCLUDES:

- factors relating to compliance with Building Regulations where applicable
- factors relating to additional non-regulatory information where applicable
- independently verified technical specification
- assessment criteria and technical investigations
- design considerations
- installation guidance
- regular surveillance of production
- formal three-yearly review.



KEY FACTORS ASSESSED

Structural aspects — the system components have adequate strength to resist the loads associated with installation loading (see section 6).

Thermal performance — the system contributes to the overall thermal performance of the wall construction (see section 7).

Risk of condensation — walls, openings and junctions with other elements will adequately limit the risk of surface condensation (see section 8).

Behaviour in relation to fire — the system is not classified as non-combustible or of limited combustibility and is restricted in some cases (see section 9).

Sound insulation — separating and internal walls with a minimum concrete core density and detailing stated in this Certificate will provide sufficient sound resistance (see section 14).

Durability — the system components are durable (see section 16).

The BBA has awarded this Certificate to the company named above for the product described herein. This product has been assessed by the BBA as being fit for its intended use provided it is installed, used and maintained as set out in this Certificate.

On behalf of the British Board of Agrément

A handwritten signature in black ink that reads 'B Chamberlain'.

Date of First issue: 5 June 2014

Brian Chamberlain
Head of approvals - Engineering

A handwritten signature in black ink that reads 'Claire'.

Claire Curtis-Thomas
Chief Executive

Certificate amended on 22 April 2020 to include Regulation 7(2) for England and Wales and new regulatory guidance for fire in Scotland.

The BBA is a UKAS accredited certification body – Number 113.

*The schedule of the current scope of accreditation for product certification is available in pdf format via the UKAS link on the BBA website at www.bbacerts.co.uk
Readers MUST check the validity and latest issue number of this Agrément Certificate by either referring to the BBA website or contacting the BBA directly.*

Any photographs are for illustrative purposes only, do not constitute advice and should not be relied upon.

British Board of Agrément

Bucknalls Lane
Watford
Herts WD25 9BA

©2014

tel: 01923 665300
clientservices@bbacerts.co.uk
www.bbacerts.co.uk

Regulations

In the opinion of the BBA, the Polarwall Insulating Concrete Formwork System, , if installed, used and maintained in accordance with this Certificate, can satisfy or contribute to satisfying the relevant requirements of the following Building Regulations (the presence of a UK map indicates that the subject is related to the Building Regulations in the region or regions of the UK depicted):



The Building Regulations 2010 (England and Wales) (as amended)

Requirement:	A1	Loading
Requirement:	A2	Ground movement
Requirement:	A3	Disproportionate collapse
Comment:		Walls formed from the system will have adequate strength and stiffness to satisfy these Requirements. See sections 6.1 and 6.13 of this Certificate.
Requirement:	B3(4)	Internal fire spread (structure)
Comment:		The system is restricted by this Requirement in some cases. See section 9.1 of this Certificate.
Requirement:	B4(1)	External fire spread
Comment:		The system is restricted by this Requirement in some cases. See sections 9.1, 9.2 and 9.4 of this Certificate.
Requirement:	C2(a)	Resistance to moisture
Comment:		Walls formed from the system can adequately limit the risk of moisture ingress from the ground. See section 11.1 of this Certificate.
Requirement:	C2(c)	Resistance to moisture
Comment:		Walls formed from the system can adequately limit the risk of surface condensation and contribute to minimising the risk of interstitial condensation. See sections 8.1 and 8.2 of this Certificate.
Requirement:	E1	Protection against sound from other parts of the building and adjoining buildings
Requirement:	E2(a)	Protection against sound within a dwelling-house etc
Comment:		Walls formed from the system can adequately meet these Requirements. See sections 14.1 to 14.3 of this Certificate.
Requirement:	L1(a)(i)	Conservation of fuel and power
Comment:		Walls formed from the system can contribute to a building meeting its Target Emission Rate. See sections 7.1 to 7.3 and 7.5 of this Certificate.
Regulation	7(1)	Materials and workmanship
Comment:		The system elements are acceptable. See section 16 of this Certificate.
Regulation:	7(2)	Materials and workmanship
Comment:		The system is restricted by this Regulation. See sections 9.1 to 9.3 of this Certificate.
Regulation:	26	CO₂ emission rates for new buildings
Regulation:	26A	Fabric energy efficiency rates for new dwellings (applicable in England only)
Comment:		Walls formed from the system can satisfy or contribute to satisfying this Regulation. See sections 7.1 to 7.3 and 7.5 of this Certificate.



The Building (Scotland) Regulations 2004 (as amended)

Regulation:	8(1)	Durability, workmanship and fitness of materials
Comment:		The system can contribute to a construction meeting this Regulation. See sections 15 and 16 of this Certificate.

Regulation:	9	Building Standards in relation to construction
Standard:	1.1(a)(b)	Structure
Standard:	1.2	Disproportionate collapse
Comment:		Walls formed from the system will have adequate strength and stiffness to satisfy this Standard, with reference to clauses 1.1.1 ⁽¹⁾⁽²⁾ to 1.1.3 ⁽¹⁾⁽²⁾ and, when suitably reinforced, clause 1.2.1 ⁽¹⁾⁽²⁾ . See sections 6.1 and 6.13 of this Certificate.
Standard:	2.1	Compartmentation
Standard:	2.2	Separation
Standard:	2.3	Structural protection
Comment:		The system is restricted by these Standards in some cases with reference to clauses 2.1.12 ⁽²⁾ , 2.2.4 ⁽²⁾ , 2.2.5 ⁽²⁾ , 2.2.6 ⁽¹⁾ , 2.2.7 ⁽¹⁾ , 2.2.8 ⁽¹⁾ and 2.3.2 ⁽¹⁾⁽²⁾ . See sections 9.1, 9.2 and 9.5 of this Certificate.
Standard:	2.4	Cavities
Comment:		The system is restricted by this Standard, with reference to clauses 2.4.2 ⁽¹⁾⁽²⁾ , 2.4.4 ⁽¹⁾ and 2.4.6 ⁽²⁾ . See section 9.1, 9.2 and 9.5 of this Certificate.
Standard:	2.6	Spread to neighbouring buildings
Comment:		The system is restricted by this Standard, with reference to clauses 2.6.5 ⁽¹⁾ and 2.6.6 ⁽²⁾ . See sections 9.1, 9.2 and 9.5 of this Certificate.
Standard:	3.4	Moisture from the ground
Comment:		Walls formed from the system can satisfy this Standard, with reference to clauses 3.4.1 ⁽²⁾ and 3.4.5 ⁽¹⁾ . See section 11.1 of this Certificate.
Standard:	3.15	Condensation
Comment:		Walls formed from the system can adequately limit the risk of surface condensation, with reference to clauses 3.15.1 ⁽¹⁾⁽²⁾ and 3.15.3 ⁽¹⁾ . Walls can contribute to minimising the risk of interstitial condensation, with reference to clauses 3.15.1 ⁽¹⁾ , 3.15.4 ⁽¹⁾ and 3.15.5 ⁽¹⁾⁽²⁾ . See sections 8.1 and 8.2 of this Certificate.
Standard:	5.1	Noise separation
Standard:	5.2	Noise reduction between rooms
Comment:		Separating walls formed from the system satisfy these Standards, with reference to clauses 5.1.1 ⁽¹⁾⁽²⁾ , 5.1.2 ⁽¹⁾⁽²⁾ , 5.1.4 ⁽¹⁾⁽²⁾ , 5.1.7 ⁽²⁾ , 5.1.8 ⁽¹⁾ , 5.2.1 ⁽¹⁾⁽²⁾ and 5.2.2 ⁽¹⁾⁽²⁾ . See section 14.1 of this Certificate.
Standard:	6.1(b)	Carbon dioxide emission
Standard:	6.2	Building insulation envelope
Comment:		The system will enable a wall to satisfy the Elemental Method of limiting fabric heat loss, with reference to clause 6.1.1 ⁽¹⁾⁽²⁾ , 6.1.4 ⁽¹⁾ , 6.1.5 ⁽¹⁾ and 6.2.1 ⁽¹⁾ of this Standard. The junctions and openings can also adequately limit heat loss by conduction and by air infiltration, with reference to clauses 6.2.4 ⁽¹⁾ and 6.2.5 ⁽¹⁾ of this Standard respectively. See sections 7.1 to 7.3, 7.5, 13.1 and 13.3 of this Certificate.
Standard:	7.1(a)(b)	Statement of sustainability
Comment:		The system can contribute to meeting the relevant requirements of Regulation 9, Standards 1 to 6 and therefore will contribute to a construction meeting a bronze level of sustainability as defined in this Standard. In addition, the system can contribute to a construction meeting a higher level of sustainability as defined in this Standard, with reference to clauses 7.1.4 ⁽¹⁾⁽²⁾ [Aspects 1 ⁽¹⁾⁽²⁾ and 2 ⁽¹⁾], 7.1.6 ⁽¹⁾⁽²⁾ [Aspects 1 ⁽¹⁾⁽²⁾ and 2 ⁽¹⁾] and 7.1.7 ⁽¹⁾⁽²⁾ [Aspect 1 ⁽¹⁾⁽²⁾]. See sections 7.1 to 7.3 and 7.5 of this Certificate.

(1) Technical Handbook (Domestic).

(2) Technical Handbook (Non-Domestic).



The Building Regulations (Northern Ireland) 2012 (as amended)

Regulation:	23(a)(i)	Fitness of materials and workmanship
Comment:	(iii)(b)	The system is acceptable. See section 16 of this Certificate.
Regulation:	28(a)(b)	Resistance to moisture and weather
Comment:		Walls formed from the system can adequately limit the risk of moisture ingress from the ground and weather. See section 11.1 of this Certificate.
Regulation:	29	Condensation
Comment:		Walls formed from the system can contribute to minimising the risk of interstitial condensation. See sections 8.1 and 8.2 of this Certificate.
Regulation:	30	Stability
Comment:		Walls formed from the system will have adequate strength and stiffness to satisfy this Regulation. See sections 6.1 to 6.13 of this Certificate.
Regulation:	31	Disproportionate collapse
Comment:		Walls formed from the system when suitably reinforced, will have adequate strength and stiffness to satisfy this Regulation. See sections 6.2 to 6.3 of this Certificate.
Regulation:	35(4)	Internal fire spread – Structure
Comment:		The system is restricted by this Regulation in some cases. See section 9.1 of this Certificate.
Regulation:	36(a)	External fire spread
Comment:		The system is restricted by this Regulation in some cases. See sections 9.1, 9.2 and 9.4 of this Certificate.
Regulation:	39(a)(i)	Conservation measures
Regulation:	40(2)	Target carbon dioxide Emissions Rate
Comment:		The system components will enable a wall or roof to satisfy the Elemental Method of limiting fabric heat loss. See sections 7.1 to 7.3, 7.5, 13.1 and 13.2 of this Certificate.
Regulation:	49	Resistance to the passage of sound
Regulation:	50(a)(b)	Protection against sound within a dwelling or room for residential purposes
Regulation:	51	Reverberation in the common internal parts of a buildings containing flats or rooms for residential purposes
Comment:		Separating walls formed from the system can satisfy this Regulation. See sections 14.1 and 14.2 of this Certificate.

Construction (Design and Management) Regulations 2007

Construction (Design and Management) Regulations (Northern Ireland) 2007

Information in this Certificate may assist the client, CDM co-ordinator, designer and contractors to address their obligations under these Regulations.

See sections: 3 *Delivery and site handling* (3.4) and 16 *General* (16.1) of this Certificate.

Additional Information

NHBC Standards 2014

NHBC accepts the use of the Polarwall Insulating Concrete Formwork System, when installed and used in accordance with this Certificate, in relation to *NHBC Standards*.

General

Polarwall Insulating Concrete Formwork System provides permanent formwork for in-situ dense aggregate concrete walls (reinforced or plain) and contributes to the thermal insulation of the finished construction. The system is for use in loadbearing and non-loadbearing internal, external and separating walls in residential and commercial buildings subject to structural and fire considerations and building use.

The system can also be used below ground, including basement construction, subject to design by a suitable qualified and experienced individual and adherence to structural design to British or European Standards (see section 6.2) and detailing in accordance with BS 8102 : 2009. However, below-ground watertight construction and protection against ingress of ground water has not been assessed and is outside the scope of this Certificate. Use of the system in any structure is subject to design limitations in accordance with British or European Standards.

Technical Specification

1 Description

1.1 Polarwall Insulating Concrete Formwork System (see Figures 1 and 2) consists:

- extruded polystyrene planking — up to 2500 mm long by 298 mm deep by 50 mm to 150 mm thick insulating boards manufactured from extruded polystyrene (see Table 1)
- plywood board — generally 2400 mm wide by 1200 high by a minimum 12 mm thick as alternative to XPS planking to either or both faces to act as temporary shuttering
- end pieces — usually extruded polystyrene cut on site from planking
- U-rail — 1524 mm in length by 50 mm wide polyvinylchloride profiled rail used to assemble formwork and located at the top and bottom of the wall. The rail has an integral arrowhead on one side to allow connection of the cross tie
- H-rail — 1524 mm in length by 50 mm wide polyvinylchloride profiled rail used to connect intermediate courses of the planking together or as an alternative to U-rail. The rail has an integral arrowhead on one side to allow connection of the cross tie
- R-rail — 1200 mm in length by 45 mm wide polyvinylchloride profiled rail used where temporary formwork is specified allowing the wall to be built without any insulating material to one or both faces. The R-rail is attached to the temporary cement particleboard or plywood shuttering
- cross-ties — nominal lengths of 100 mm, 150 mm, 200 mm, 250 mm and 300 mm and manufactured from acetal. Cross ties are used to attach the inner and outer formwork together. Each tie has locating pins (either 18 mm wide for the 100 mm and 150 mm ties, and 25 mm wide for the 250 mm and 300 mm) positioned across the cross tie to securely fasten any reinforcing bars
- corner rail pieces — H-and U corner profiles with an external dimension leg of 200 mm. The internal sides have an arrowhead allowing cross-ties to be attached to the rail opposite.

Figure 1 XPS Polarwall System

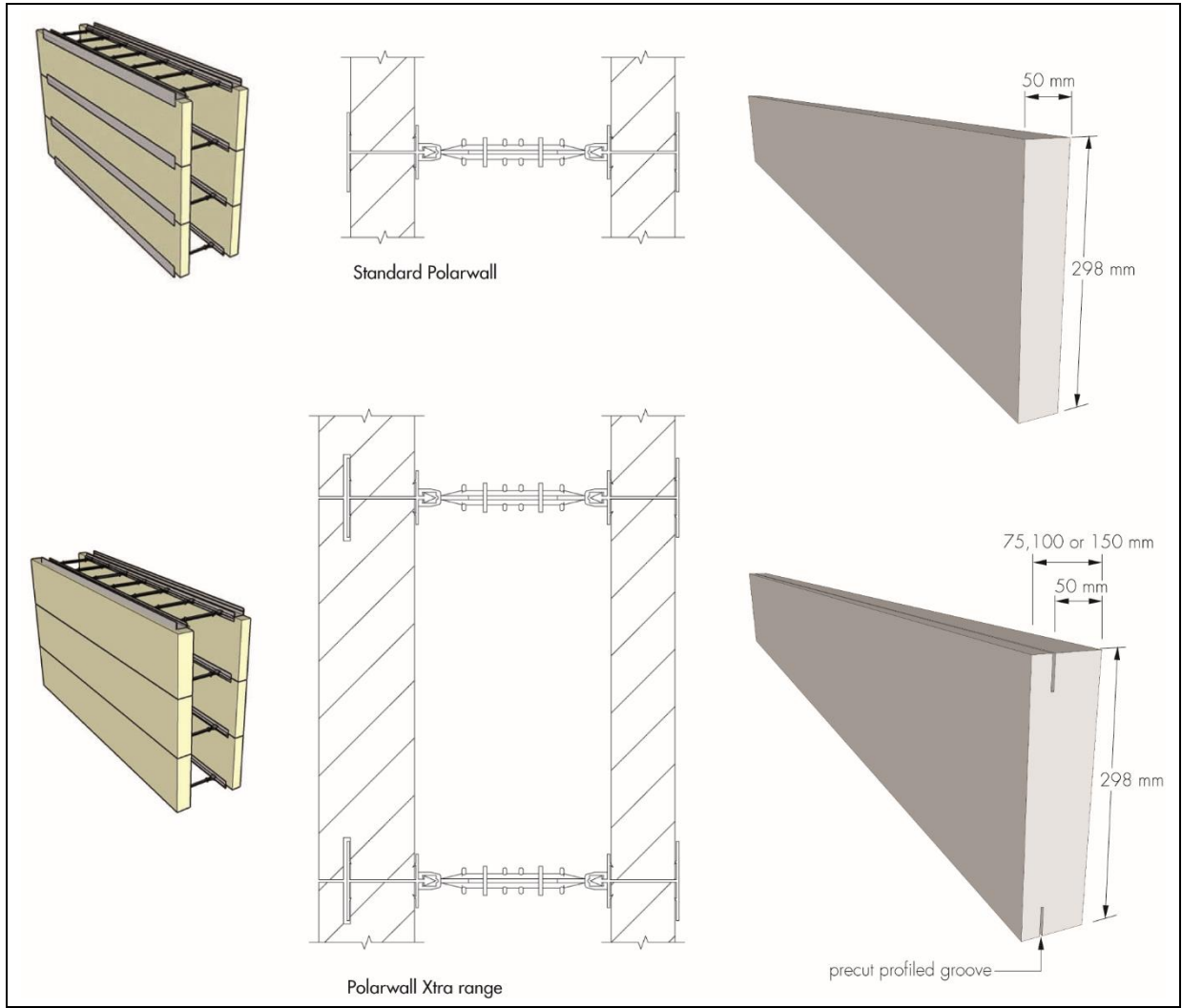

Figure 2 System components

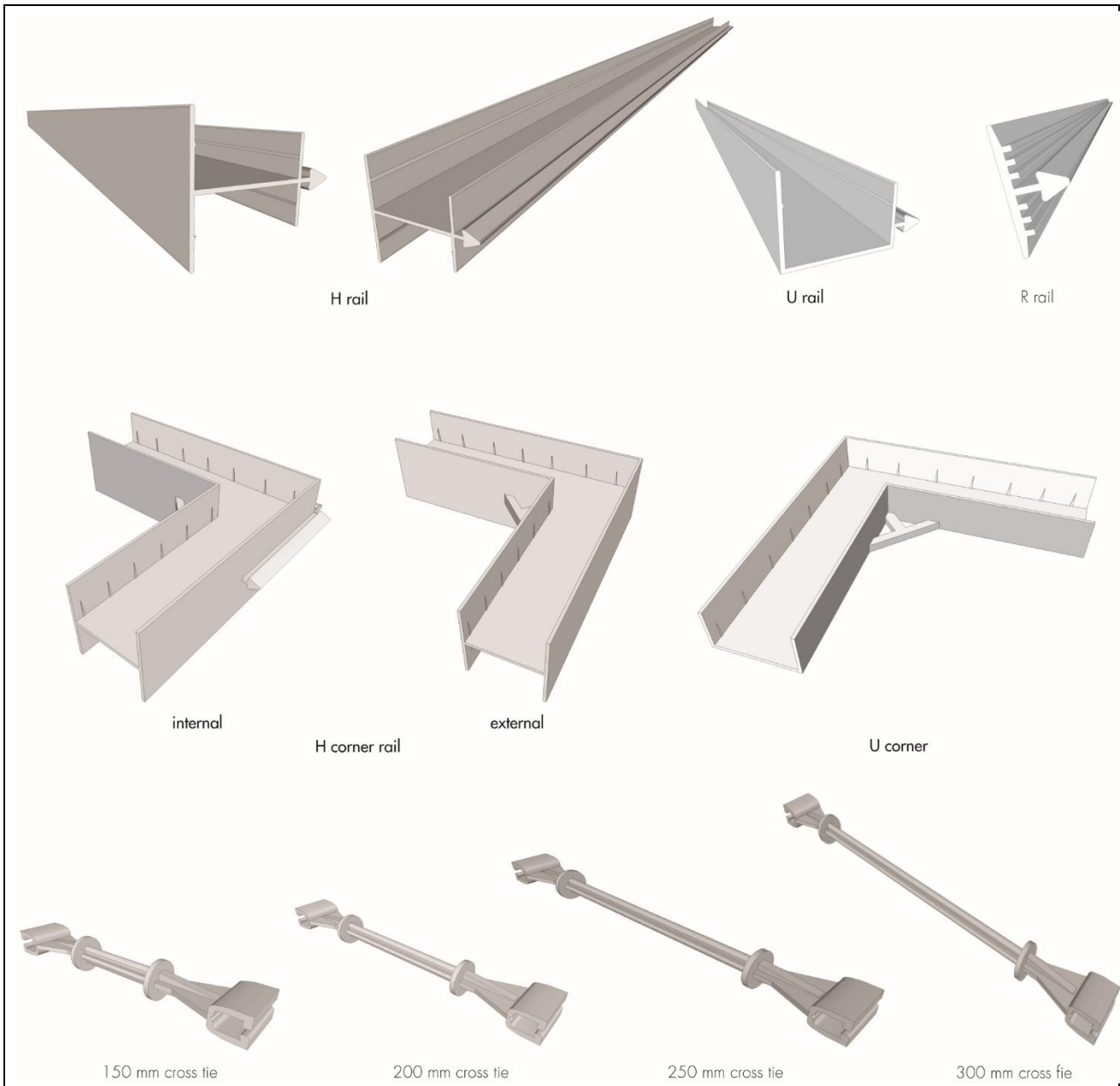

Table 1 XPS Planking specification

Board type	Length (mm)	Height (mm)	Thickness outer (mm)	Thickness inner (mm)
Standard Polarwall	2400	298	50	50
Polarwall Xtra Range – X25	2400	298	75	50
Polarwall Xtra Range – X50	2400	298	100	50
Polarwall Xtra Range – X100	2400	298	150	50

1.2 The concrete infill core used in conjunction with system is outside the scope of this Certificate should be sourced from a QSRMC⁽¹⁾-registered or BSI-Kitemarked supplier and must be of the specification given in Table 2. The Certificate holder recommends a pumpable grade concrete. Admixtures used to assist placement must comply with BS EN 934-2 : 2001 or BS EN 480-1 : 2006.

(1) Quality Scheme for Ready Mixed Concrete.

Table 2 Concrete specification

Characteristic (units)	Specification
Unreinforced	C20/25
Reinforced	C28/35
Minimum density (kg·m ⁻³)	2000
Minimum mass (acoustic) (kg·m ⁻²)	415
Slump class	S2
Target slump (mm) ⁽¹⁾	70-80
Maximum aggregate size (mm)	10
Water : cement ratio (%)	<60%

(1) In accordance with BS EN 206-1 : 2000 and BS EN 12350-2 : 2000.

1.3 Other component items and finishes specified for use with the system, but not assessed or covered by this Certificate are:

- steel reinforcement (bar or mesh) — where required, should comply with BS 4449 : 2005 or BS 4483: 2005 and sourced from a CARES registered supplier
- external masonry — brickwork, or stonework fixed in accordance with the provisions of BS EN 1996-1-2 : 2005 or the appropriate part of BS 8298 : 2010 respectively
- external render — in accordance with BS EN 13914-1 : 2005 and suitable for use with the system
- acrylic or silicone render — suitable render products in accordance with BS EN 13914-1 : 2005 for use with the system
- brick slip systems — the Certificate holder's advice should be sought for systems having third-party certification
- brickwork/stonework ties — to BS EN 845-1 : 2003
- alignment/support system — as recommended by the Certificate holder
- basement waterproofing membrane — the Certificate holder's advice should be sought
- plasterboard internal linings — to BS EN 520 : 2004 and BS 8212 : 1995
- fire barriers.

2 Manufacture

2.1 The insulation formwork planking is manufactured from extruded polystyrene (XPS) and the rails and associated elements from polyvinylchloride or acetal.

2.2 As part of the assessment and ongoing surveillance of product quality, the BBA has:

- agreed with the manufacturer the quality control procedures and product testing to be undertaken
- assessed and agreed the quality control operated over batches of incoming materials
- monitored the production process and verified that it is in accordance with the documented process
- evaluated the process for management of nonconformities
- checked that equipment has been properly tested and calibrated
- undertaken to carry out the above measures on a regular basis through a surveillance process, to verify that the specifications and quality control operated by the manufacturer are being maintained.

3 Delivery and site handling

3.1 Good site practice should be observed to prevent damage to the formwork elements.

3.2 The formwork elements and rails are supplied in shrink wrapped packs. All packaged components are clearly labelled with product type and code number, allowing full traceability of supply. The wrapping should not be opened until the contents are required.

3.3 The formwork planks and rails must be stored in their shrink wrapped packs on firm, level and dry ground. If stored outside packs must be further protected from the weather using opaque plastic sheeting or tarpaulin. The cross-ties and 'H' and 'U' profiled rail corners are supplied in cardboard boxes and should be similarly stored.

3.4 Care must be taken when handling the XPS elements to avoid damage and contact with solvents or materials containing volatile organic components such as newly treated timber. The elements must not be exposed to open flame or other ignition sources.

Assessment and Technical Investigations

The following is a summary of the assessment and technical investigations carried out on Polarwall Insulating Concrete Formwork System.

Design Considerations

4 Use

4.1 Polarwall Insulating Concrete Formwork System is for use as permanent formwork for in-situ dense aggregate concrete walls with the XPS component contributing to the thermal insulation of the finished construction to loadbearing and non-loadbearing reinforced and unreinforced concrete external, internal and separating walls in domestic and commercial buildings, subject to design limitations regarding height and fire risk. Use in any structures is subject to design limitations in accordance with British or European Standards.

4.2 Consideration should be given at the design stage to the positioning of damp-proof courses and gas membranes, wall fixings, service pipes and joists, relative to the position of connecting assemblies. They can be incorporated by following the Certificate holder's details. Care must be taken not to damage the elements and cold bridging effects must be considered.

4.3 Subject to design by a suitable qualified and experienced individual, the formwork may be used for constructing basement walls. The BBA has not assessed the system for forming watertight construction or for forming buildings subjected to ground water or hydrostatic pressure.

4.4 The system is for use with the internal and external finishes specified in section 1.3 of this Certificate.

4.5 Foundations should be adequate to support the intended loads.

5 Practicability of installation

The system must only be installed by trained and/or approved by the Certificate holder.

6 Structural performance

General



6.1 The system is satisfactory for use in loadbearing and non-loadbearing walls as permanent formwork for in-situ dense aggregate concrete.

6.2 Structures subject to the national Building Regulations incorporating the system should be designed to the relevant sections of BS 8007 : 1987, BS 8102 : 2009, BS 8110-1 : 1997 or BS EN 1991-1-4 : 2005, BS EN 1992-1-1 : 2004 and BS EN 1992-1-2 : 2004 and certified by a suitable qualified and experienced individual.

6.3 Other buildings not subject to any of the Regulations defined in section 6.2 should also be built in accordance with the same Standards.

6.4 The concrete cannot be readily examined after casting, therefore, care must be taken to ensure full compaction is achieved as specified in BS 8110-1 : 1997, Section 2, or BS EN 1992-1-1 : 2004, Sections 4 and 8. If required, compaction may be checked by removal of a section of plank to allow observation and securely replaced.

6.5 Storey-height walls using the system are normally constructed in one continuous lift (see sections 17.4). Particular care is necessary to maintain alignment during concrete filling, and checking between lifts. Propping

systems (see section 19.6) used in conjunction with the formwork must be checked prior to and during the concrete pour to ensure stability and alignment is maintained.

6.6 With respect of concrete placement and particularly use of poker vibration for compaction of wet concrete (see also section 17.5), the *Polarwall Insulating Concrete Formwork Technical Manual* must be consulted.

6.7 When the formwork is used to construct a watertight basement, an effective waterproofing method should be employed, ensuring correct detailing and jointing methodology to Certificate holder's instructions and the requirements of BS 8102 : 2009 for Types A, B and C watertight construction.

6.8 Generally, facing brickwork or stonework should be attached using suitable wall ties that are fixed through the formwork and into the concrete core with suitable fixings. Fixings should be applied to the depth recommended by the Certificate holder.

6.9 Heavy attachments or finishes, fixed either internally or externally, must be attached via support systems designed to take account of the applied load using suitable fixings or plates fixed or cast into the concrete core. The H, R and U rails must not be used to support any internal or external loads.

Strength and stability

6.10 The XPS has the following declared strength properties given in Table 3.

Characteristic	Standard	value
Bending strength ($\text{kN}\cdot\text{m}^{-2}$)	BS 3837-1 and BS EN 13164	350
Compressive strength ($\text{kN}\cdot\text{m}^{-2}$)	BS 826	300
Nominal density ($\text{kg}\cdot\text{m}^{-3}$)	BS EN 602	35

6.11 Walls constructed using the formwork may be treated as conventional reinforced or unreinforced (plain) concrete walls. Particular attention should be made to the type of concrete mix used to ensure segregation does not occur and the wet concrete is allowed to flow freely around formed openings and through congested areas of reinforcement, particularly when the system is used in basement construction.

6.12 The nominal concrete cover to reinforcement should be that appropriate to exposure classes X0 and XC1 described in BS 8500-1 : 2006, Table A.1, and BS EN 206-1 : 2000, Table 1.

6.13 To achieve structurally stable formwork during the construction process, the formwork must be braced sufficiently to resist the loads imparted by wind action and construction loads. A typical system of temporary bracing should be designed to give lateral support during the pouring of the concrete and curing stage. The Certificate holder is able to provide an alignment/propping system that includes screw props on one side that can be adjusted prior to, during and immediately following pouring operations.

7 Thermal performance



7.1 The thermal performance of each building incorporating the forms must be evaluated in accordance with the relevant national Building Regulations, and is the responsibility of the overall designer of the building.

7.2 Calculations of the thermal transmittance (U value) of a specific wall construction should be carried out in accordance with BS EN ISO 6946 : 2007 and BRE Report 443 : 2006, using the following thermal conductivity $\lambda_{90/90}$ value.

7.3 Typical extruded polystyrene insulation thermal conductivity (λ_D) values are given in Table 4.

Table 4 Typical thermal properties

Thickness (mm)	λ_D value ($W \cdot m^{-1} \cdot K^{-1}$)
50	0.034
75	0.036
100	0.036
150	0.036

7.4 The overall U value will depend on the construction adopted, the Certificate holder can provide further details on request.



7.5 Junctions with other elements should be designed to limit heat loss. Detailed guidance for junctions and on limiting heat loss by air infiltration can be found in:

England and Wales — Approved Documents to Part L and, for new thermal elements to existing buildings, Accredited Construction Details (version 1.0) (for new-build, see also SAP 2009, Appendix K, and the *iSBEM User Manual*)

Scotland — Accredited Construction Details (Scotland)⁽¹⁾

Northern Ireland — Accredited Construction Details (version 1.0).

(1) Flexible approaches on existing buildings are given in the Technical Handbooks.

8 Risk of condensation

Surface condensation



8.1 External walls can adequately limit the risk of surface condensation.

Interstitial condensation

8.2 Subject to the construction used and amount of vapour being produced, the risk of interstitial condensation will be minimal. Any vapour build-up will be low and will dissipate during the summer months. For the purposes of calculating condensation risk a water vapour resistance factor (μ) of 150 may be taken for the XPS planks.

9 Behaviour in relation to fire



9.1 The XPS component has a declared Euroclass E reaction to fire rating (to BS EN 13501 : 2007 + A1 : 2009).

9.2 The system is not classified as non-combustible or of limited combustibility.



9.3 In England and Wales, the system should not be used for external walls of buildings with a storey 18 m or more above ground level and which contains: one or more dwellings, an institution, a room for residential purposes (excluding any room in a hostel, hotel or boarding house), student accommodation, care homes, sheltered housing, hospitals or dormitories in boarding schools or non-domestic buildings less than one meter from a boundary.



9.4 In England, Wales and Northern Ireland, the system is unrestricted in terms of proximity to a boundary and, for constructions comprising an outer leave of brick or concrete at least 75 mm thick and with cavities closed (with cavity barriers in Northern Ireland) around openings and at the top of the wall, is unrestricted in terms of height, other than those described in section 9.3. For other constructions, the product should not be used in buildings with a floor more than 18 m above the ground.



9.5 In Scotland, the system may be used without restriction on height or proximity to a relevant boundary, provided it is installed with an outer leave of masonry at least 75 mm thick, and has a cavity barrier around all openings in the wall and at the top of the wall head. For other constructions, the system should not be used 1 m or less from a boundary or in a building with a floor more than 11 m above the ground. Additional restrictions apply to separating elements.

9.6 Designers should refer to the relevant national Building Regulations and guidance for detailed conditions of use, particularly in respect of requirements for fire resistance, cavity closers and barriers, fire stopping of service penetrations and combustibility limitations for other materials and components used in the overall wall construction.



9.7 Concrete walls constructed from the system have been assessed in accordance with BS 8110-2 : 1985, Table 4.6. Fire resistance values for various reinforced concrete wall thicknesses formed using the elements are given in this table. Alternatively, if reinforced concrete walls are designed in accordance with BS EN 1992-1-1 : 2004, fire resistance values for various concrete wall thicknesses set out in BS EN 1992-1-2 : 2004, Table 5.4, can be used, subject to cover and design load considerations. For unreinforced walls acting as fire walls, the minimum thickness requirements set out in BS EN 1992-1-2 : 2004, clause 5.4.2, must be taken into account. This assessment does not take account of any additional protection provided by the internal and external finishes. The use of the formwork with the specified finishes will not reduce the fire resistance of the concrete wall. Fire resistance values achievable using the system are set out in Tables 5 and 6.

Table 5 Minimum concrete core thickness for walls with vertical reinforcement (BS 8110-2 only)⁽¹⁾

Reinforcement and concrete specification	Minimum thickness (mm) of concrete required in the formwork excluding any combustible finish for a fire resistance (loadbearing capacity, integrity and insulation)				
	Duration (minutes)				
	30	60	90	180	240
Walls with less than 4% reinforcement made from dense aggregate	150	150	200		
Walls with 0.4% to 1% reinforcement made from dense aggregate with 25 mm cover to reinforcement	100	150	150	200	
Walls with over 1% reinforcement made from dense aggregate with 25 mm cover to reinforcement			100	150	200

(1) Concrete walls constructed from the formwork system have been assessed in accordance with BS 8110-2 : 1985, Table 4.6 (note: actual core widths stated in Table 4).

Table 6 Minimum concrete core thickness for loadbearing reinforced concrete walls (from BS EN 1992-1-2 : 2004, Table 5.4)

Standard fire resistance	Minimum dimensions (mm) Wall thickness/axis distance ⁽¹⁾ for			
	$\mu_{fi}^{(2)} = 0.35$		$\mu_{fi}^{(2)} = 0.7$	
	wall exposed on one side	wall exposed on two sides	wall exposed on one side	wall exposed on two sides
REI 30	100/10 ⁽³⁾	120/10 ⁽³⁾	120/10 ⁽³⁾	120/10 ⁽³⁾
REI 60	110/10 ⁽³⁾	120/10 ⁽³⁾	130/10 ⁽³⁾	140/10 ⁽³⁾
REI 90	120/20 ⁽³⁾	140/10 ⁽³⁾	140/25 ⁽³⁾	170/25

(1) Centre of reinforcement to nearest exposed surface.

(2) The definition of μ_{fi} is given in BS EN 1992-1-1 : 2004, section 5.3.2(3).

(3) Normally, the cover specified in BS EN 1992-1-1 : 2004 will control this distance.

10 Weathertightness

Resistance to rain ingress is provided by the external finishes but this has not been assessed by the BBA. Care should be taken to ensure the design and construction comply with the relevant good practice described in the applicable codes and the Certificate holder's Installation procedures.

11 Damp-proofing and waterproofing



11.1 The formwork elements will not transmit moisture by capillary action. The concrete wall formed with the system should be constructed using the specified concrete recommended by the Certificate holder.

11.2 Use of the system below ground to resist the effects of hydrostatic head or ground water ingress has not been assessed and is not covered by this Certificate. The recommendations given in BS 8102 : 2009 should be adopted in respect to the watertightness of the whole structure (see also section 4.3). A suitable collector drain and backfilling medium should be provided to eliminate the build-up of hydrostatic head behind the wall, where required. The Certificate holder should be consulted for advice on suitable waterproofing materials and methods of waterproofing.

11.3 Window and door openings and penetrations of the concrete, such as pipe entries or formwork ties, must also be securely sealed to maintain watertightness. The advice of the Certificate holder should be sought on suitable details.

12 Proximity of flues and appliances

When installing the product in close proximity to certain flue pipes and/or heat-producing appliances, the following provisions to the national Building Regulations are acceptable:

England and Wales — Approved Document J3

Scotland — Technical Standards 3.18, clause 3.18.5⁽¹⁾, and 3.19, clause 3.19.4⁽¹⁾

Northern Ireland — Technical Booklet L.

(1) Technical Handbook (Domestic).

13 Airtightness



13.1 Buildings can achieve adequate resistance to heat loss by air infiltration provided there is effective sealing around junctions between units during site assembly. Care should be taken to ensure that junctions with other elements and openings comply with the relevant guidance for airtightness as given in the relevant documents referred to in section 7.5.



13.2 In England, Wales and Northern Ireland, completed buildings are subject to pre-completion testing for airtightness in accordance with the requirements of:

England and Wales — Approved Document L1A (section 43) L2A (section 20B)

Northern Ireland — Technical Booklets F1 (Sections 2.59 to 2.69) and F2 (Sections 2.72 to 2.77).



13.3 In Scotland, completed dwellings are subject to testing air permeability in accordance with the requirements of Mandatory Standard 6.2 (clause 6.2.5). Alternatively, where a default design value of $15 \text{ m}^3 \cdot \text{m}^{-2} \cdot \text{h}^{-1}$ at 50 Pa is stated in demonstrating compliance under Mandatory Standard 6.1, testing is not required.

14 Sound insulation



14.1 Separating walls are subject to pre-completion testing in accordance with the national Building Regulations:

England and Wales — Approved Document E, Section 1

Scotland — Technical Standard 5.1, section 5.1.2(1)

Northern Ireland — Technical Booklet G.

14.2 Internal walls and walls flanking separating walls in new dwellings and rooms for residential purposes should have a minimum mass per unit area, excluding finishes, in excess of $120 \text{ kg} \cdot \text{m}^{-2}$.



14.3 Separating walls with a concrete core density greater than $2200 \text{ kg}\cdot\text{m}^{-3}$ and thickness of 200 mm, will achieve a minimum mass per unit area for the core of $415 \text{ kg}\cdot\text{m}^{-2}$ and can contribute to providing the requirements of Approved Document E, Section 2.

15 Maintenance and repair



Minor repairs to the formwork can be carried out prior to concrete pouring using plywood strapping.

16 Durability



Concrete walls constructed with the system will have a service life of not less than 60 years provided they are designed in accordance with section 6. The formwork will have a similar service life provided it is protected from damage by the external and internal finishes of the wall construction (constituting a 'mild' exposure environment) and these are adequately maintained.

Installation

17 General

17.1 Installation of the Polarwall Insulating Concrete Formwork System is carried out in accordance with the Certificate holder's installation instructions, by trained and/or approved operatives and the requirements of BS 5975 : 2008 and BS 8000-2.1 : 1990. Continuous supervision during placing and compacting of the concrete must be provided by the contractor. The formwork elements can be cut using conventional woodworking tools.

17.2 Attention is drawn to the need for accurate levelling of the foundation and initial setting out of the propping which should prevent the need for significant adjustments to be made.

17.3 In general, concrete should be placed by boom pump and nozzle although small quantities of concrete, e.g. to window sills, can be placed by hand. The requirements given in sections 17.4 and 17.5 must be observed during placing and compacting of the concrete.

17.4 Concrete must be compacted in accordance with the requirements of BS 8110-1 : 1997 or BS EN 1992-1-1 : 2004. Concrete placement should not exceed a flow rate of 12 cubic metres per hour, in passes not exceeding 0.5 metre high for reinforced concrete and 0.9 metre high for unreinforced walls. The total daily pour height must not exceed 3 metres.

17.5 For unreinforced walls placement of the concrete hand tamping or rodding is adequate. For reinforced walls poker vibrators, not exceeding 35 mm diameter, should be employed as the ties, rails and XPS planking are easily damaged. Alternatively, external vibration on the rails can be applied with care.

17.6 The concrete can be placed in freezing conditions as it will be thermally protected by insulation provided by the formwork. However, the temperature of the concrete being placed must be between 5°C and 30°C . In air temperatures below 5°C or temperatures above 25°C the top of the formwork should be protected to aid curing.

17.7 Suitably durable and mechanically adequate fixings, reinforcing starter bars or support brackets must be used for all structural elements, e.g. floors and roofs, and must be post-drilled or cast into the concrete core. The XPS planks forming each of the system elements must not be used as a structural medium.

18 Preparation

18.1 The preparation, installation and support of the panels must be in accordance with the Certificate holder's installation instructions.

18.2 The foundation must be level, smooth finished, cleaned off and within a tolerance of ± 10 mm in any direction. Any out-of-tolerances must be made good prior to placement of formwork. The system can accommodate stepped foundations.

18.3 As part of the pre-assembly process ladders are formed using the rails and cross-ties (see Figure 3). The cross-ties are snap fixed to the rails, either by hand or using a snapper machine supplied by the Certificate holder. Typically the cross-ties are at 225 mm centres with a minimum of seven cross-ties per 1524 mm ladder length.

Figure 3 Typical Polarwall Ladder

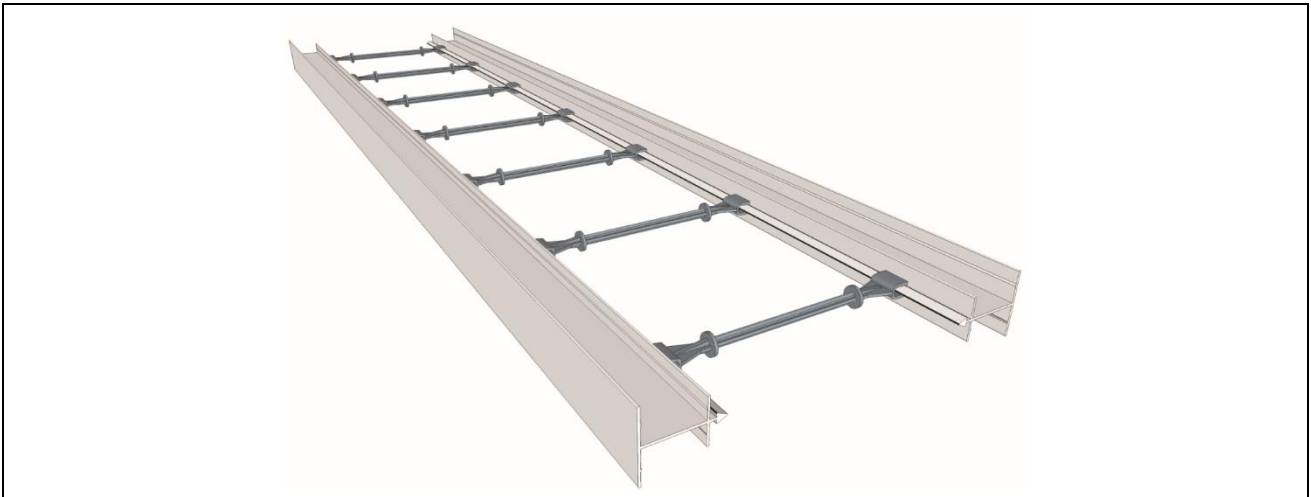

19 Procedure

Wall assembly

19.1 The line of the walls to be built is first checked and the two 'H' or 'U' rails fixed to the foundation.

19.2 Starting at the corners and working into the centre point of each wall, the first plank course is pushed firmly into the U or H-rails allowing the Polarwall Standard planking to be constructed into a tight, rigid formwork. Where the Xtra Polarwall planking is used, to accommodate the extra thickness, the U and H-Rails are inserted using the pre-cut profiled groove within the planking.

19.3 The pre-constructed H-rail/cross-tie ladders (see section 18.3) are next pushed onto the base course planks ensuring a tight fit. The line and level is then checked.

19.4 Depending on the footing detail required, the following and subsequent courses are then built up ensuring that vertical joints do not coincide. End pieces must be inserted into any opening sides and any reinforcement required for structural design purposes as erection of the formwork proceeds.

19.5 It is recommended that structural steel mesh reinforcement is used and laid along the cross-ties. However, the type and quantities of reinforcement placed within the system are dependent on design and detail requirements. Alternatively, where horizontal reinforcing bars are used these can be wired to the cross-ties, where required. Vertical reinforcement is secured to horizontal reinforcement at the required centres and secured using standard fixing methods. Bar lapping lengths in accordance with BS 8110-1 : 1997 or BS EN 1992-1-1 : 2004 should be adopted. All reinforcement should be accurately positioned to ensure that the minimum required cover to the concrete is provided. Starter or dowel bars are recommended depending on reinforcement requirements or engineer's specification. Ties can be moved but should not be cut or modified when locating reinforcement.

19.6 During construction, it is essential that effective temporary bracing and propping of the formwork takes place to ensure stability, level, straightness and plumb of walls during erection and concrete pour operations. The installer must ensure that adequate bracing is provided to cope with site conditions. As a minimum the full height of the assembled formwork must be supported at corners and along the wall lengths with bracings at a maximum 2 metre centres. As the rigidity of the formwork is reduced by openings additional bracing and propping must be introduced to maintain stability.

19.7 Where the specified storey height is not a multiple of the plank width the top plank can be cut to suit.

Windows and doors

19.8 Window and door openings are formed by cutting the formwork planks and rails at the desired locations. Once formed plank inserts are used to close the void soffit, sill and reveals. Alternatively openings can be lined with timber framing, to receive door and window frames. All openings and lintels formed as part of the erection works must be adequately braced and supported until the concrete has attained its minimum design strength.

Penetrations

19.9 Sleeves for ducts or service penetrations can be positioned within the formwork prior to concrete pouring. Service entry points to basement walls should be avoided.

Concrete placement

19.10 Prior to concrete pouring, a check is carried out on the formwork system to ensure conformity to design and layout, correct alignment and plumb, and that temporary bracings and props are secured. Reinforcement should be checked for correct cover distance and rigidity. Where reinforcement is only provided above openings the individual bars should extend at least 500 mm beyond the opening span.

19.11 The wall core is formed by placing or pouring concrete into the formwork. For concrete pumping, a 75 mm reducer and hose should be used. The concrete pump should be set at a pumping rate such that excessive pressure is not allowed on the sides of the formwork. The stream of concrete should be aimed directly into the void and away from corners.

19.12 The formwork should also be checked for alignment and plumb before proceeding with the next traverse. This will also allow the first pour to stiffen. The next traverse proceeds in the same manner until the first storey-height has been reached. At window and door openings, concrete should be poured either side of each opening up to sill level and the concrete allowed to begin its initial set before the next pour is commenced.

19.13 A typical wall construction details are shown in Figure 4.

Heavy wall loads

19.14 Heavy wall loads (such as structural members) should be supported by the concrete core and not the formwork planks or rails. This can be achieved by the use of timber blocks screwed or bolted into the concrete core, or cast-in anchor bolts and metal plates.

Figure 4 Typical installation details

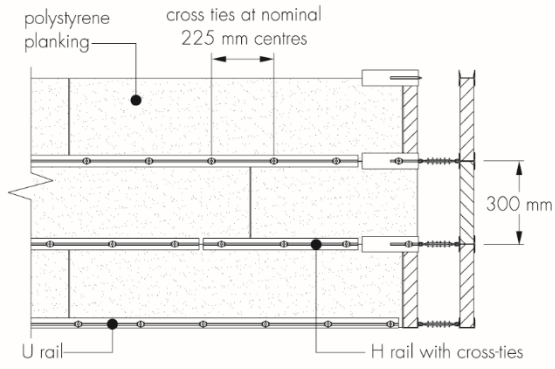

standard detail (internal view)

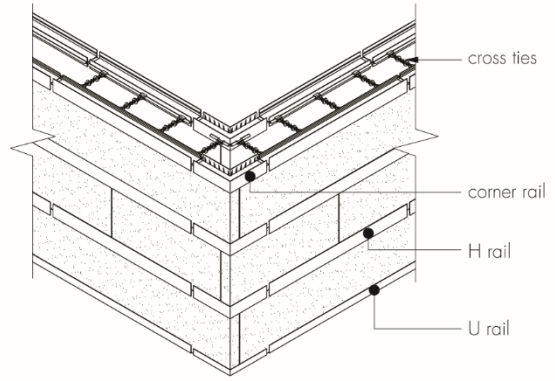

corner detail (external view)

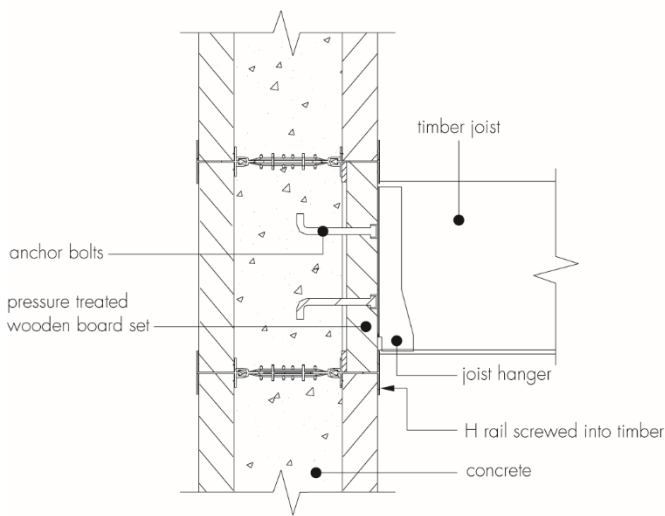

suspended floor detail (cross section)

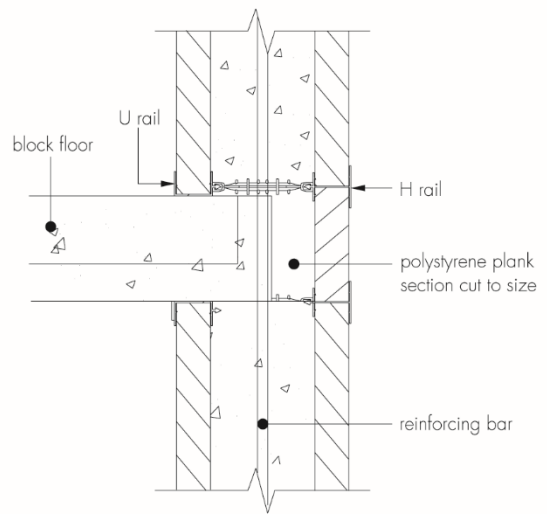

beam and block floor detail (cross section)

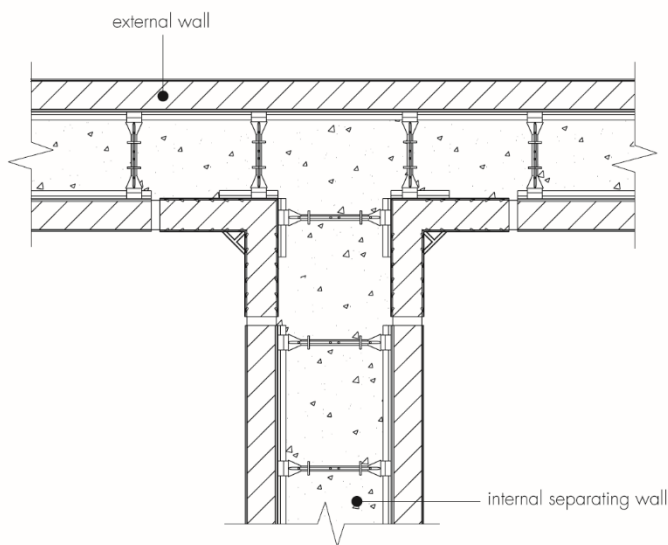

connecting wall detail (plan view)

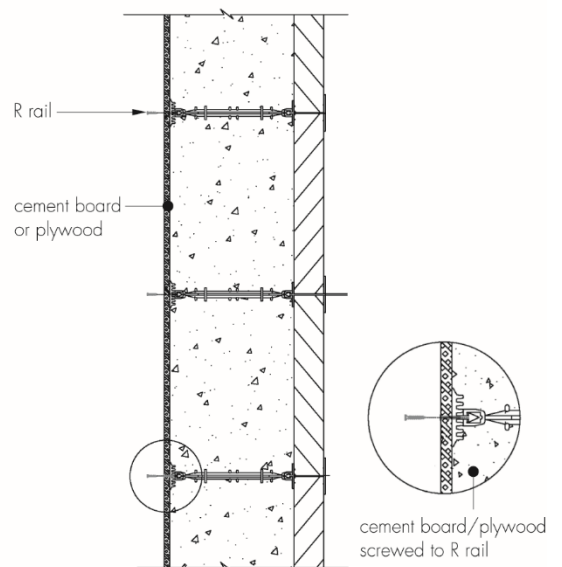

wall detail using r rail

Figure 4 Typical installation details (continued)

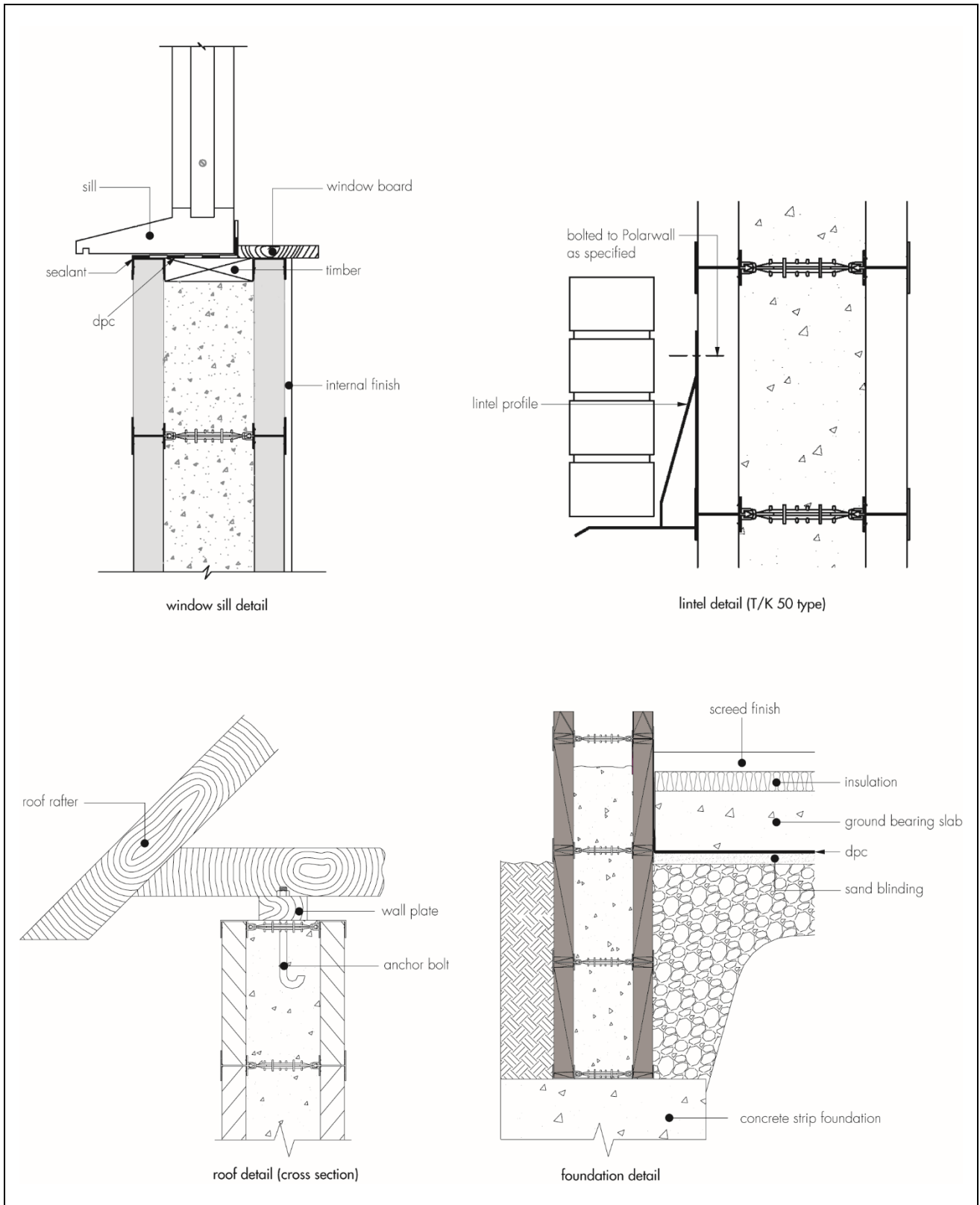

20 Finishing

Backfilling

20.1 Backfilling around bottom layers of formwork to the ground floor or basement walls should not take place until the floor has been placed.

Electrical and plumbing installation

20.2 Electrical and plumbing services can be fixed within the formwork or into the concrete core by cutting chases into the XPS using a router. All electrical services should be ducted. Any services introduced should conform to national Building Regulation and Health and Safety requirements. Further details on fixing methods can be obtained from the Certificate holder

Wall penetrations

20.3 Penetrations of the concrete, such as pipe entries or formwork ties, must be securely sealed to maintain watertightness. The advice of the Certificate holder should be sought on suitable details.

Internal wall finishes

20.4 A range of internal lightweight finishes can be applied or fixed directly to the rails of the system. These can be screw-fixed into the rails or glued to the XPS using compatible adhesive subject to Certificate holder's advice.

External wall finishes

20.5 Subject to structural design considerations, external cladding systems can be fixed via battens or rails into the concrete core using stainless steel fixings. Render systems can be applied directly to the XPS surface in conjunction with metal or plastic lathing and suitable fixings. Further details can be obtained from the Certificate holder.

20.6 The recommendations given in BS 8102 : 2009 should be adopted in respect of the watertightness of the whole structure. The advice of the Certificate holder should be sought on particular applications.

Technical Investigations

21 Investigations

21.1 A site visit was carried out to witness the installation process including construction of formwork, placement of reinforcement and pouring of concrete and performance of the cross-ties.

21.2 An assessment was made on test data relating to thermal performance.

Bibliography

- BRE Report 443 : 2006 *Conventions for U-value calculations*
- BS 826 : 1996 *Thermal insulating products for building applications. Determination of compression behaviour*
- BS 3837-1 : 2004 *Expanded polystyrene boards — Boards and blocks manufactured from expandable beads. Requirements and test methods*
- BS 4449 : 2005 *Steel for the reinforcement of concrete — Weldable reinforcing steel — Bar coil and decoiled product — Specification*
- BS 4483 : 2005 *Steel fabric for the reinforcement of concrete — Specification*
- BS 5975 : 2008 + A1 : 2011 *Code of practice for temporary works procedures and the permissible stress design of falsework*
- BS 8007 : 1987 *Code of practice for design of concrete structures for retaining aqueous liquids*
- BS 8102 : 2009 *Code of practice for protection of structures against water from the ground*
- BS 8110-1 : 1997 *Structural use of concrete — Code of practice for design and construction*
- BS 8110-2 : 1985 *Structural use of concrete — Code of practice for special circumstances*
- BS 8212 : 1995 *Concrete — Complementary British Standard to BS EN 206-1 Method of specifying and guidance for the specifier*
- BS 8298-1 : 2010 *Code of practice for the design and installation of natural stone cladding and lining — General*
- BS 8298-2 : 2010 *Code of practice for the design and installation of natural stone cladding and lining Traditional handset external cladding*
- BS 8298-3 : 2010 *Code of practice for the design and installation of natural stone cladding and lining Stone-faced pre-cast concrete cladding systems*
- BS 8500-1 : 2006 *Concrete — Complementary British Standard to BS EN 206-1 Method of specifying and guidance for the specifier*
- BS EN 206-1 : 2000 *Concrete — Specification, performance, production and conformity*
- BS EN 480-1 : 2006 *Admixtures for concrete, mortar and grout — Test methods — Reference concrete and reference mortar for testing*
- BS EN 520 : 2004 *Gypsum plasterboards — Definitions, requirements and test methods*
- BS EN 845-1 : 2003 *Specification for ancillary components for masonry — Ties, tension straps, hangers and brackets*
- BS EN 934-2 : 2001 *Admixtures for concrete, mortar and grout — Concrete admixtures — Definitions and requirements, conformity, marking and labelling*
- BS EN 1991-1-4 : 2004 *Eurocode 1 : Actions on structures — General actions*
- BS EN 1992-1-1 : 2004 *Eurocode 2 : Design of concrete structures — General rules and rules for buildings*
- BS EN 1992-1-2 : 2004 *Eurocode 2 : Design of concrete structures — General rules and rules for buildings — General rules. Structural fire design*
- BS EN 1996-1-2 : 2005 *Eurocode 6 : Design of masonry structures — General rules — Structural fire design*
- BS EN 12350-2 : 2000 *Testing fresh concrete Slump test*
- BS EN 12524 : 2000 *Building materials and products — Hygrothermal properties — Tabulated design values*

22 Conditions

22.1 This Certificate:

- relates only to the product/system that is named and described on the front page
- is issued only to the company, firm, organisation or person named on the front page – no other company, firm, organisation or person may hold or claim that this Certificate has been issued to them
- is valid only within the UK
- has to be read, considered and used as a whole document – it may be misleading and will be incomplete to be selective
- is copyright of the BBA
- is subject to English Law.

22.2 Publications, documents, specifications, legislation, regulations, standards and the like referenced in this Certificate are those that were current and/or deemed relevant by the BBA at the date of issue or reissue of this Certificate.

22.3 This Certificate will remain valid for an unlimited period provided that the product/system and its manufacture and/or fabrication, including all related and relevant parts and processes thereof:

- are maintained at or above the levels which have been assessed and found to be satisfactory by the BBA
- continue to be checked as and when deemed appropriate by the BBA under arrangements that it will determine
- are reviewed by the BBA as and when it considers appropriate.

22.4 The BBA has used due skill, care and diligence in preparing this Certificate, but no warranty is provided.

22.5 In issuing this Certificate the BBA is not responsible and is excluded from any liability to any company, firm, organisation or person, for any matters arising directly or indirectly from:

- the presence or absence of any patent, intellectual property or similar rights subsisting in the product/system or any other product/system
- the right of the Certificate holder to manufacture, supply, install, maintain or market the product/system
- actual installations of the product/system, including their nature, design, methods, performance, workmanship and maintenance
- any works and constructions in which the product/system is installed, including their nature, design, methods, performance, workmanship and maintenance
- any loss or damage, including personal injury, howsoever caused by the product/system, including its manufacture, supply, installation, use, maintenance and removal
- any claims by the manufacturer relating to CE marking.

22.6 Any information relating to the manufacture, supply, installation, use, maintenance and removal of this product/system which is contained or referred to in this Certificate is the minimum required to be met when the product/system is manufactured, supplied, installed, used, maintained and removed. It does not purport in any way to restate the requirements of the Health and Safety at Work etc. Act 1974, or of any other statutory, common law or other duty which may exist at the date of issue or reissue of this Certificate; nor is conformity with such information to be taken as satisfying the requirements of the 1974 Act or of any statutory, common law or other duty of care.