

**NCCTL**  
Non-combustible  
Cavity Tray Lintel

Non-combustible

**Doc B**  
Compliant

# Why NCCTL

## The Non-combustible Challenge

Fire safety is a vital consideration in the design of high rise buildings.



### Regulatory Response

The introduction of Buildings Regulations Document B (Fire Safety) 2019 was an initial regulatory response to the Grenfell tragedy of 2017.

## Document B (Fire Safety) 2019 Section B4 External Fire Spread

### Buildings over 18m in height

Contains one or more dwellings, contains an institution, or contains a room for residential purposes (excludes any room in a hostel, hotel or boarding house).

### Non-Combustible Cavity Trays Required

Materials which become part of an external wall, or specified attachment, of a relevant building are of European Classification A2-s1, d0 or A1, CLASSIFIED IN ACCORDANCE WITH BS EN 13501-1:2007+A1:2009.

### Exemptions

- DPC / Membranes / Cavity Trays when used between two masonry skins
- Windows and Doors
- Fire Barriers etc.

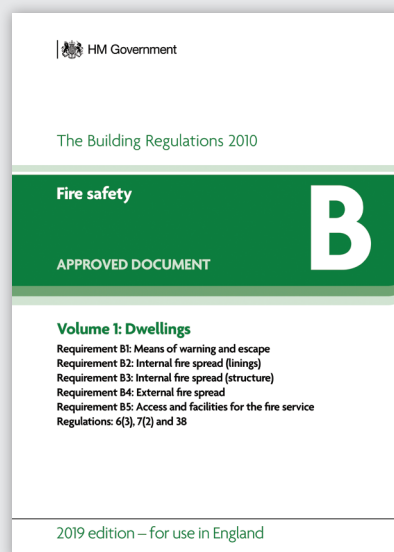

# What does this mean for Lintels?

In buildings over 18m in height, Document B prevents the use of plastic DPCs, galvanised lintels cannot be used without a DPC, as the DPC protects the galvanised surface against attack from chemicals present within mortars etc. Stainless steel trays cannot be used with galvanised lintels due to galvanic corrosion caused by reactions between dissimilar materials.

## IG has developed a solution

The IG Non-combustible Cavity Tray Lintel offers a non-combustible stainless steel single leaf lintel with combined cavity tray.

For use in an exterior masonry skin in conjunction with a non masonry inner leaf such as a steel frame system, the NCCTL is a highly efficient and practical solution to the challenge of non-combustible cavity detailing.

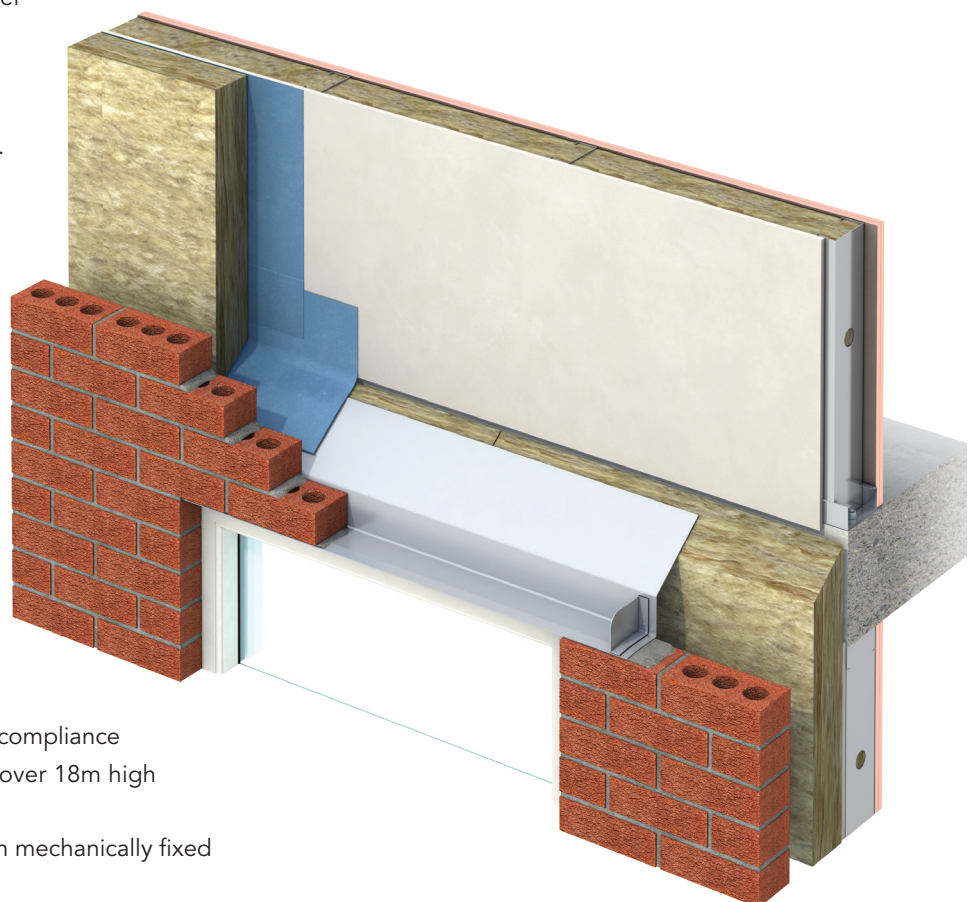

- ✓ Non-combustible Class A1 for compliance with Document B in buildings over 18m high
- ✓ Stainless steel construction with mechanically fixed watertight stop ends
- ✓ Facilitates speedy installation
- ✓ Utilises traditional onsite trades, no special skills required
- ✓ Standard load-bearing capabilities



# Features

## Stainless Steel



Manufactured in Class A1 grade 304 austenitic stainless steel, the NCCTL represents the ideal specification for all applications requiring Document B compliance. The NCCTL can also be ordered in grade 316 austenitic stainless steel if required in coastal locations.

## Ease of Installation

The NCCTL is a practical lintel solution which is built into the outer leaf as normal and gives easy access to membranes and insulation on the inner leaf.

The ease of installation in the outer leaf combines the structural load bearing lintel with the advantages of a self supporting cavity tray. These features allow the profiling of insulation and the overlap positioning of the cavity facing membrane, if required. This should be completed independently, once the lintel is securely built into the brickwork.

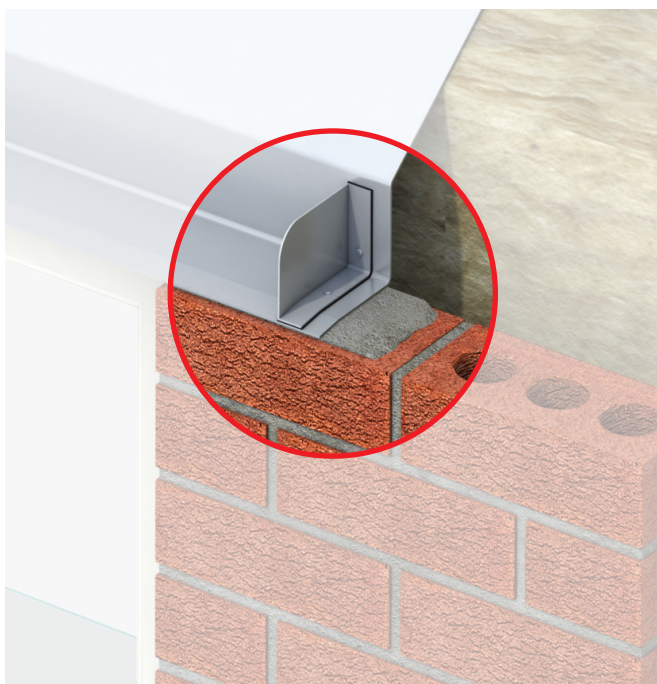
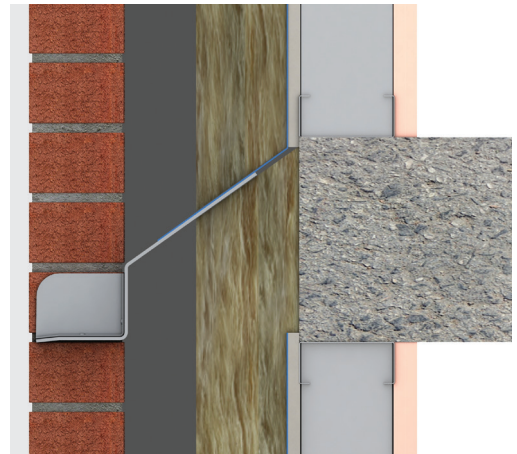

## Patented Mechanically Fixed Stopends

Watertight mechanically fixed sealed stop-ends are positioned within brickwork perpendicular joints. The patented mechanically fixed stop-ends remove additional operations usually performed by the bricklayer and ensure any moisture present on the NCCTL cannot travel horizontally over the ends of the lintel but is channelled outwards instead.

The NHBC states that the single biggest reason for buildings already occupied to be reopened is problems relating to stop-ends, joints in cavity trays and DPCs around lintels. IG's patented mechanically fixed solution alleviates installation errors onsite.

## Requirements of a Cavity Tray

NHBC Standards Chapter 6.1 states that cavity trays should be provided at all interruptions to the cavity (e.g. windows and door openings and air bricks) **Unless Otherwise Protected.**

Cavity trays should:

- provide an impervious barrier and ensure that water drains outwards
- cover the end of the lintel and project at least 25mm beyond the outer face of the cavity closer or, where a combined cavity tray and lintel is acceptable, give complete protection to the top of the reveal and vertical DPC
- provide drip protection to door and window heads
- have a 140mm minimum vertical height from the inside face of the outer leaf to the outside of the inner leaf
- be shaped to provide 100mm minimum vertical protection above points where mortar droppings could collect
- be provided where the cavity is bridged by air bricks, etc. and the DPC should extend 150mm beyond each side of the bridge
- where not otherwise protected (e.g. by a roof at an appropriate level), be provided over meter boxes
- be in one continuous piece or have sealed or welded joints.

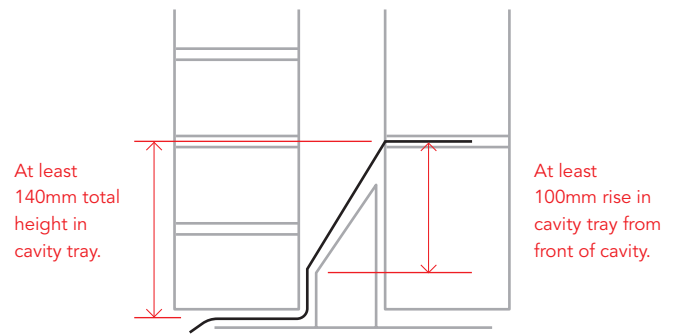

## Loading Assessment



The NCCTL accommodates openings up to 3047.5mm as standard. Contact the IG Lintels technical team for openings over 3047.5mm.

## Adjustability

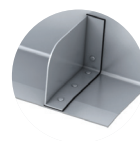

Mechanically fixed stopends are repositioned within the perpend joint to accommodate brickwork openings.

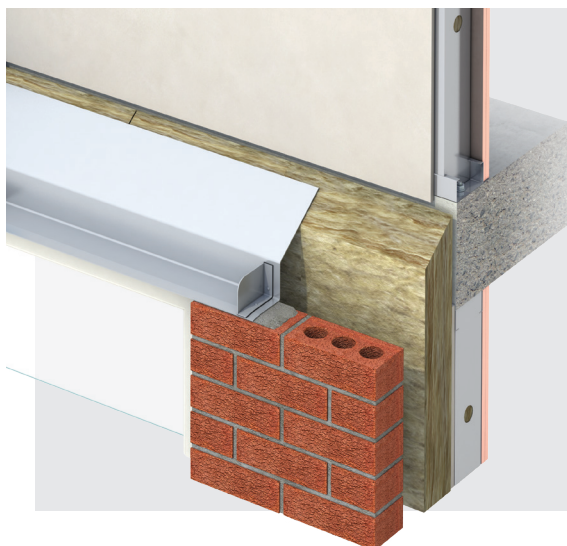

## Standard Range

- Lintel lengths are based on brickwork openings sizes
- Lintel range is based on 215mm stretcher bond as standard
- NCCTLs accommodate openings up to 3047.5mm as standard

Other variations are available on request. Please contact the IG Technical engineers with requirements for any variation from the above.

# How it works

## ✓ Determine brickwork opening

As the IG team prefixes the stopends to the lintel, the NCCTL must be specified by Brickwork opening dimensions. Brickwork course and bond layout immediately below the lintel does not affect overall lintel length but will influence the lintel position over an opening.

NB: Stopend positions are based on 215mm stretcher bond as standard. Please notify IG Technical if you require any variation from this.

Lintel supported on reveals by full bricks

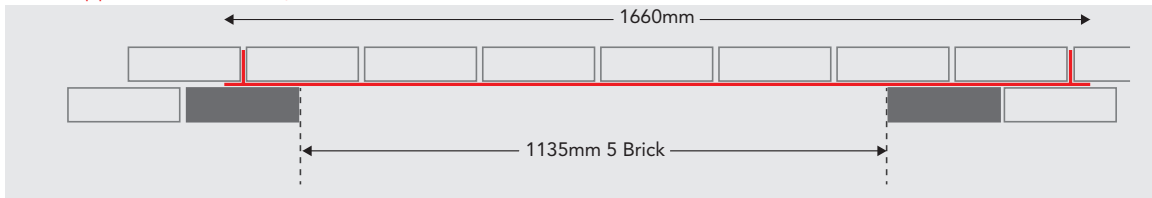

Lintel supported on reveals by half bricks

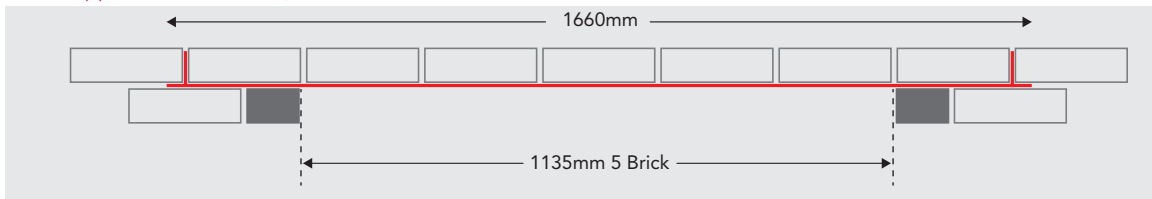

Lintel supported on reveals by a full brick and a half brick

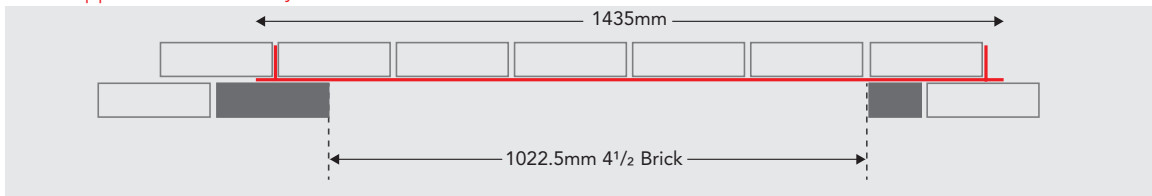

Lintel supported on reveals by a half brick and a full brick

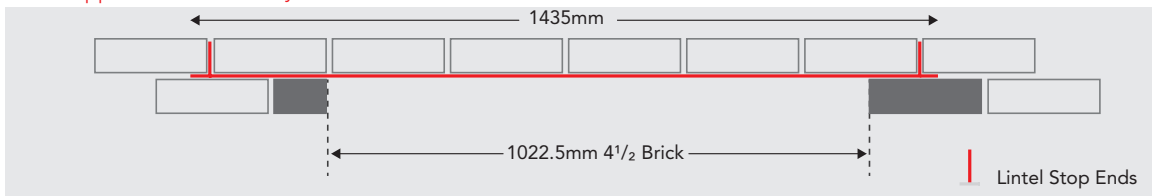

## ✓ Assess loading

The images above demonstrate how the mechanically fixed stopends can be positioned over the same opening dimension widths, taking into account, various brickwork bonds upon which the lintel may be bearing on.

The NCCTL range has been designed to accommodate any of the shown variations, therefore ensure to specify the required product by opening size.

# Brickwork opening and lintel length table

## Brickwork Opening

mm	Brick Modules	Lintel Length (mm)
460	2	985
572	2½	985
685	3	1210
797	3½	1210
910	4	1435
1022	4½	1435
1135	5	1660
1247	5½	1660
1360	6	1885
1472	6½	1885
1585	7	2110
1697	7½	2110
1810	8	2335
1922	8½	2335
2035	9	2560
2147	9½	2560
2260	10	2785
2372	10½	2785
2485	11	3010
2597	11½	3010
2710	12	3235
2822	12½	3235
2935	13	3460
3047	13½	3460

# NCCTL 140 Loading Tables

## Standard Range

Brickwork Opening (mm)	460 - 1472	1585-1922	2035-3047
Lintel Height (mm)	179	229	279
Total UDL (kN)	6	10	8

## Heavy Duty Range

Brickwork Opening (mm)	460 - 1472	1585-1922	2035-3047
Lintel Height (mm)	229	279	279
Total UDL (kN)	13	17	18

## Extra Heavy Duty Range

Brickwork Opening (mm)	460 - 1472	1585-1922
Lintel Height (mm)	279	279
Total UDL (kN)	26	36

\* Other cavity sizes available upon request.

## Lintel Height

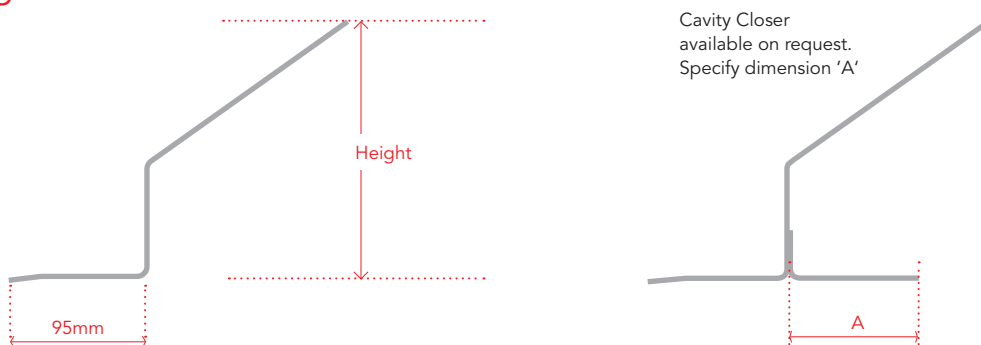



# Installation Guide



Lintels should be installed with a minimum end bearing of 150mm taking into account the positioning of the lintel's stop ends. The Lintel should be bedded in mortar and levelled along its length and across its width.

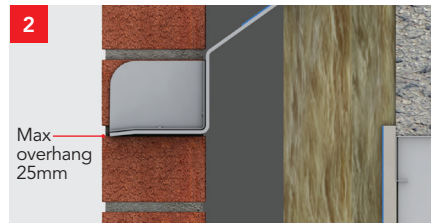

The masonry above the Lintel should be built in accordance with BS EN 1996-2-2006. Masonry must not overhang the lintel flange by more than 25mm.

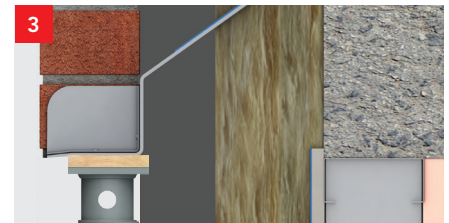

Temporary propping beneath the Lintel can be used to facilitate speed of construction.



The external lintel flange must project beyond the window / door frame.



Do not cut lintels to length or modify them in any way without consulting an IG engineer.

## Other products in the Non-Combustible Range

Non-combustible Cavity Tray

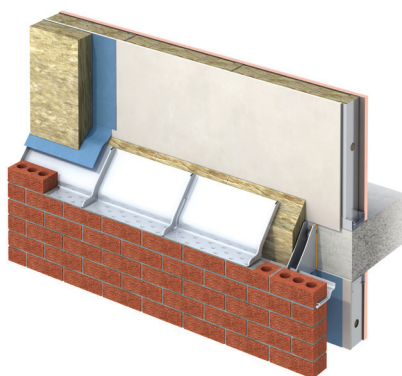

Non-combustible Insulation Retaining Clip

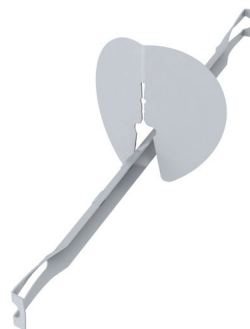

Non-Combustible Weep Vent

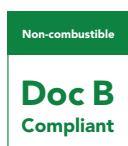



Steel Lintels

**IG Cwmbran**

Avondale Road  
Cwmbran  
Gwent  
NP44 1XY

T +44 (0)1633 486486

**IG Swadlincote**

Ryder Close  
Cadley Hill Industrial Estate  
Swadlincote, South Derbyshire  
DE11 9EU

T +44 (0)1283 200150

**IG Ireland**

Ballyreagh Industrial Estate  
Cookstown, Co. Tyrone  
Northern Ireland  
BT80 9DG

T +44 (0)28 8676 2184

Lintels Hotline

**01633 486486**