

PROFILE

The **Filter Kit** (KTF) has been designed to filter the impurities caused by the oxidation of the molds and of the connections in general. These products allow for a mechanical filtering of the entire plant. They are suitable for new plants or may be retrofitted to those already existing.

Main features:

- High quality stainless steel
- Minimal pressure drops (less than 0,1 bar at the maximum delivery with clean filter)
- Minimal maintenance required (cleaning operations possible even when the unit is functioning)
- Space saving dimensions

The **filter kit** includes two pressure probes that may be connected to the **PMR6-G** to control the filter efficiency level. When the accumulated impurities cause a pressure delta beyond 0,5 bar an alarm will signal the need for maintenance.

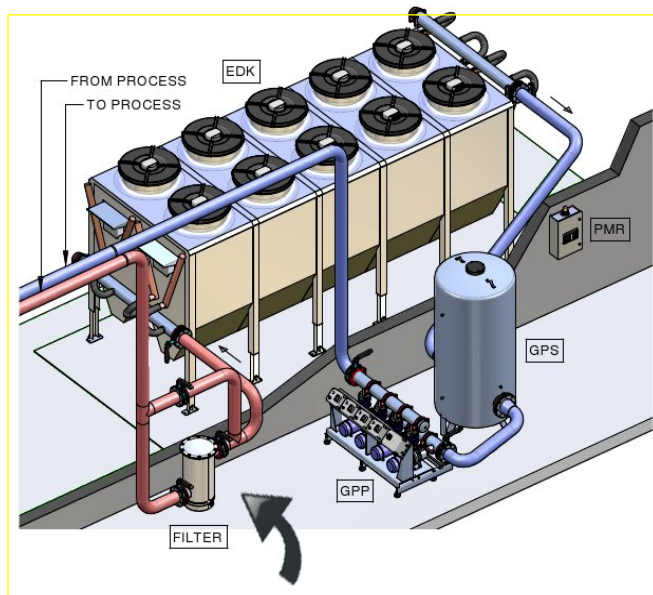
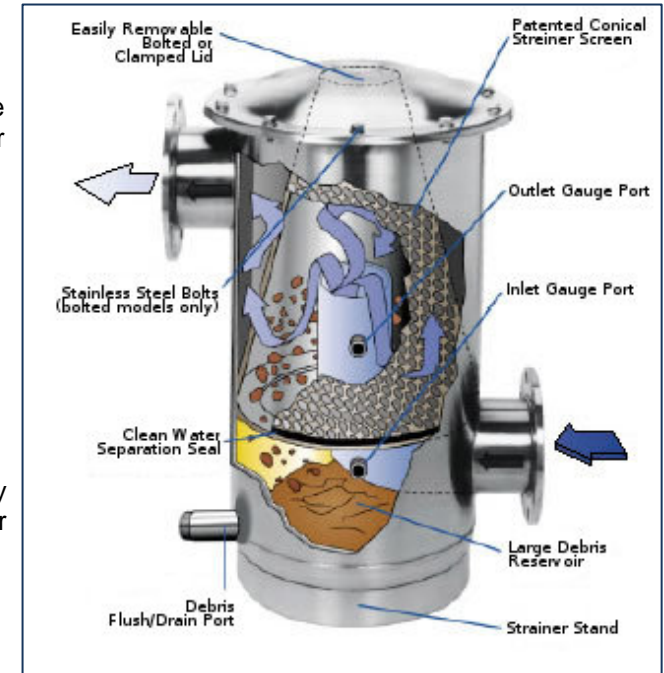

Model	Max flow m ³ /h	inlet diameter		Connect. Victaulic®	Dimensions			Weight kg
		mesh	micron		L mm	P mm	H mm	
Filter kit 2"	22	100	140	2"	261	222	416	7
Filter kit 3"	45	100	140	3"	379	228	562	14
Filter kit 4"	80	100	140	4"	488	292	643	27
Filter kit 6"	165	100	140	6"	622	431	902	57
Filter kit 8"	300	100	140	8"	796	584	1229	91
Filter kit 10"	450	100	140	10"	1100	762	1512	181