

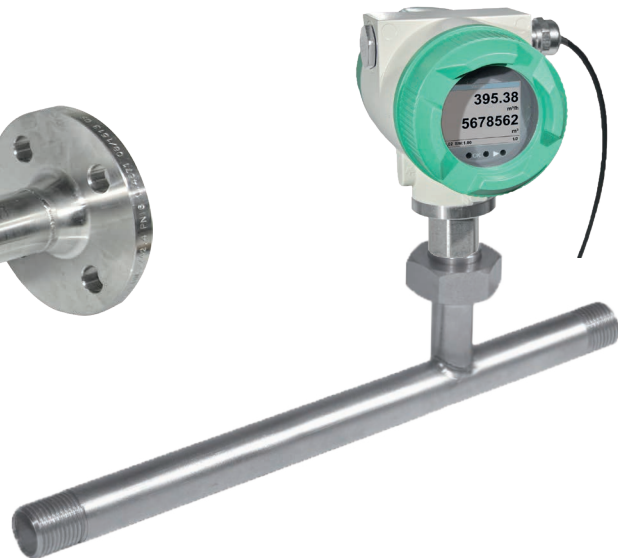

VA 570 - Inline flow meter



Flange version



Version with pipe thread
R thread or NPT thread

VA 570 is supplied with an integrated measuring section. The measuring sections are available in flanged version or with R resp. NPT thread.

A special feature is the removable measuring head. So the measuring unit can be removed easily and quickly for calibration or cleaning purposes without having to dismount the measuring section intricately. During this period the measuring section is sealed by a closing cap (accessory).

The screwing with centering device ensures that the sensor is positioned accurately in the center when screwing it into the measuring section furthermore it grants an exact positioning in the flow direction. This avoids unnecessary measuring faults.

Special measurement technology features:

- 4 values in the display: Flow, total consumption, velocity, temperature. Units freely adjustable
- All measured values, settings like gas type, inner diameter, serial number and so on retrievable via Modbus RTU
- Comprehensive diagnosis functions readable at the display or remote access via Modbus like e. g. exceeding of max/min values °C, calibration cycle, error codes, serial number
- Notification in case of exceeding of the calibration cycle
- Standard version accuracy 1.5 % of m.v. \pm 0.3 % of f.s.
- Precision version accuracy 1.0 % of m.v. \pm 0.3 % of f.s.
- Measuring span of 1 : 1000 (0.1 up to 224 m/s)
- Configuration and diagnosis via display, hand-held instrument PI 500, PC service software on-site
- Gas type (air, nitrogen, oxygen, argon and so on) freely adjustable via PC service software or external device DS 400, DS 500, PI 500
- Reference conditions °C and mbar/hPa freely adjustable
- Zero-point adjustment, leak flow volume suppression
- Pressure loss negligible

Special mechanical features:

- Robust impact-proof aluminum die cast housing for the outdoor area IP 67
- All medium-touching parts made from stainless steel 1,4571
- On request with ATEX approval ATEX II 2G Ex d IIC T4 (up to 120 °C)
- On request with DVGW approval for natural gas (up to 16 bar)
- Pressure rang up to 16 bar, special version up to 40 bar
- Temperature range up to 180 °C
- No moving parts, no wear out
- Sensor tip very robust, easy to clean
- Housing turnable, display turnable by 180°

Measuring range - Flow VA 570

		1/2"	3/4"	1"	1 1/4"	1 1/2"	2"	2 1/2"	3"
		m ³ /h (cfm)	m ³ /h (cfm)	m ³ /h (cfm)	m ³ /h (cfm)	m ³ /h (cfm)	m ³ /h (cfm)	m ³ /h (cfm)	m ³ /h (cfm)
Reference conditions DIN 1945 / ISO 1217: 20 °C, 1000 mbar									
Air	Low Speed (50 m/s)	20 (14)	45 (25)	75 (45)	140 (80)	195 (115)	320 (190)	550 (325)	765 (450)
	Standard (92,7 m/s)	45 (25)	85 (50)	145 (85)	265 (155)	365 (215)	600 (350)	1025 (600)	1420 (835)
	Max (185 m/s)	90 (50)	175 (100)	290 (170)	530 (310)	730 (430)	1195 (700)	2050 (1205)	2840 (1670)
	High Speed (224 m/s)	110(60)	215 (125)	355 (210)	640 (375)	885 (520)	1450 (850)	2480 (1460)	3440 (2025)
Adjustment to DIN 1343: 0 °C, 1013.25 mbar									
Argon (Ar)	Low Speed (50 m/s)	35 (20)	75 (40)	120 (70)	220 (130)	305 (180)	505 (295)	865 (510)	1200 (705)
	Standard (92,7 m/s)	70 (40)	135 (80)	230 (135)	415 (245)	570 (335)	935 (550)	1605 (945)	2225 (1310)
	Max (185 m/s)	140 (80)	275 (160)	460 (270)	830 (485)	1140 (670)	1870 (1100)	3205 (1885)	4440 (2615)
	High Speed (224 m/s)	170 (100)	335 (195)	555 (325)	1005 (590)	1385 (815)	2265 (1330)	3880 (2285)	5380 (3165)
Carbondi-oxide (CO₂)	Low Speed (50 m/s)	20 (14)	45 (25)	75 (45)	140 (80)	195 (115)	320 (185)	545 (320)	760 (445)
	Standard (92,7 m/s)	45 (25)	85 (50)	145 (85)	260 (155)	360 (210)	590 (345)	1015 (595)	1405 (825)
	Max (185 m/s)	90 (50)	175 (100)	290 (170)	525 (305)	720 (425)	1185 (695)	2030 (1190)	2810 (1655)
	High Speed (224 m/s)	105 (60)	210 (125)	350 (205)	635 (370)	875 (515)	1430 (840)	2455 (1445)	3405 (2000)
Nirogen (N₂)	Low Speed (50 m/s)	20 (13)	40 (25)	70 (40)	130 (75)	180 (105)	295 (175)	505 (300)	705 (415)
	Standard (92,7 m/s)	40 (20)	80 (45)	135 (75)	240 (140)	335 (195)	550 (320)	945 (555)	1305 (770)
	Max (185 m/s)	80 (45)	160 (95)	270 (155)	485 (285)	670 (395)	1100 (645)	1885 (1110)	2610 (1535)
	High Speed (224 m/s)	100 (55)	195 (115)	325 (190)	590 (345)	815 (475)	1330 (780)	2280 (1340)	3165 (1860)
Oxygen (O₂)	Low Speed (50 m/s)	20 (13)	45 (25)	75 (40)	135 (80)	185 (110)	305 (180)	525 (310)	730 (430)
	Standard (92,7 m/s)	40 (25)	80 (45)	140 (80)	250 (145)	345 (205)	570 (335)	980 (575)	1355 (795)
	Max (185 m/s)	85 (50)	165 (95)	280 (165)	505 (295)	695 (410)	1140 (670)	1955 (1150)	2710 (1590)
	High Speed (224 m/s)	105 (60)	205 (120)	340 (200)	610 (360)	845 (495)	1380 (810)	2365 (1390)	3280 (1930)
Nitrous Oxide (N₂O)	Low Speed (50 m/s)	20 (14)	45 (25)	75 (45)	140 (80)	190 (110)	315 (185)	540 (320)	750 (440)
	Standard (92,7 m/s)	40 (25)	85 (50)	140 (85)	260 (150)	355 (210)	585 (345)	1005 (590)	1395 (820)
	Max (185 m/s)	85 (50)	170 (100)	285 (170)	520 (305)	715 (420)	1170 (690)	2010 (1180)	2785 (1640)
	High Speed (224 m/s)	105 (60)	210 (120)	345 (205)	630 (370)	865 (510)	1420 (835)	2435 (1430)	3375 (1985)
Natural gas (NG)	Low Speed (50 m/s)	15 (8)	25 (15)	45 (25)	85 (50)	115 (65)	190 (110)	325 (190)	450 (265)
	Standard (92,7 m/s)	25 (15)	50 (30)	85 (50)	155 (90)	215 (125)	355 (205)	605 (355)	840 (495)
	Max (185 m/s)	50 (30)	105 (60)	170 (100)	310 (185)	430 (250)	705 (415)	1210 (710)	1680 (985)
	High Speed (224 m/s)	65 (35)	125 (70)	210 (120)	380 (220)	520 (305)	855 (500)	1465 (865)	2035 (1195)



Optional: Connection to different Bus systems

There are different options available for connection to modern Bus systems:

- Ethernet interface (Modbus-TCP) / PoE
- M-BUS
- Modbus-RTU
- Profibus DP interface (in processing)
- Profinet interface (in processing)
- HART (in processing)



Ethernet Modbus-TCP

M12 Ethernet Port, x-coded

HART

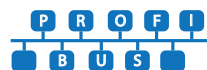

M-Bus

Further accessories see pages 82 to 86

VA 570 - Inline flow sensor

Example order code VA 570:

0695 0570_A1_B1_C1_D1_E1_F1_G1_H1_I1_J1_K1_L1_M1_R1

Outer thread measuring section	
A1	R outer thread
A2	NPT outer thread
A3	Flange version DIN EN 1092-1
A4	Flange ANSI 16.5 Class 150 lbs
A5	Flange ANSI 16.5 Class 300 lbs

Option display	
B1	with integrated display
B2	without display

Option signal output / Bus connection	
C1	2 x 4...20 mA analog output galv. isolated, pulse output RS 485 (Modbus-RTU)
C2	Profibus DP, 2 x 4...20 mA analog output galv. isolated, pulse output RS 485 (Modbus-RTU)
C4	1 x 4...20mA analog output not galvanically isolated, pulse output, RS485 (Modbus RTU)
C5	Ethernet-Interface (Modbus/TCP), 1 x 4...20 mA analog output (not galvanically isolated), pulse output, RS 485 (Modbus-RTU)
C8	M-Bus, 1 x 4 ... 20 mA analog output (not electrically isolated), pulse output, RS 485 (Modbus-RTU)
C9	Ethernet-Interface PoE (Power over Ethernet) (Modbus/TCP), 1 x 4...20 mA analog output (not galvanically isolated), pulse output, RS 485 (Modbus-RTU)

Calibration	
D1	no real gas calibration - gas adjustment via gas constant
D2	real gas calibration in the gas type as selected below

Gas type	
E1	Compressed air
E2	Nitrogen (N2)
E3	Argon (Ar)
E4	Carbon dioxide (CO2)
E5	Oxygen (O2)
E6	Nitrous oxide (N2O)
E7	Natural gas (NG)
E8	Helium (He)
E9	Propane (C3H8)
E10	Methane (CH4)
E11	Biogas (Methan 50% : CO2 50%)
E12	Hydrogen (H2)
E90	Further gas / please indicate gas type (on request)
E91	Gas mixture / please indicate mixture ratio (on request)

Reference conditions	
F1	20°C, 1000 hPa
F2	0°C, 1013,25 hPa
F3	15°C, 981 hPa
F4	15°C, 1013,25 hPa

Maximum pressure	
G1	16 bar
G2	40 bar

Surface condition	
H1	standard version
H2	special cleaning - oil and grease free (e. g. for oxygen applications and so on)
H3	Silicone free version including special cleaning oil and grease free

Accuracy class	
I1	± 1,5% of measure value ± 0,3% of f.s.(standard)
I2	± 1% of measure ± 0,3% of f.s. (precision)

Maximum gas temperature at the sensor tip	
J1	up to 120°C gas temperature (only for ATEX version)
J2	up to 180°C gas temperature (standard version)

Approvals	
K1	Non-explosive area - no approval
K2	ATEX II 2G Ex d IIC T4
K3	DVGW approval for natural gas (maximum pressure 16 bar)

Measuring range (see table)	
M1	Max version (185 m/s)
M2	Low speed version (50 m/s)
M3	Standard version (92,7 m/s)
M4	High Speed version (224 m/s)

Special measuring range	
R1	Special measuring range (Please indicate in case of order)

Order no. VA 570

DESCRIPTION	ORDER-NO.
VA 570 flow meter with integrated 1/2" measuring section	0695 0570 + order code A...R_
VA 570 flow meter with integrated 3/4" measuring section	0695 0571
VA 570 flow meter with integrated 1" measuring section	0695 0572
VA 570 flow meter with integrated 1 1/4" measuring section	0695 0573
VA 570 flow meter with integrated 1 1/2" measuring section	0695 0574
VA 570 flow meter with integrated 2" measuring section	0695 0575
VA 570 flow meter with integrated DN 15 measuring section with flange	0695 2570
VA 570 flow meter with integrated DN 20 measuring section with flange	0695 2571
VA 570 flow meter with integrated DN 25 measuring section with flange	0695 2572
VA 570 flow meter with integrated DN 32 measuring section with flange	0695 2573
VA 570 flow meter with integrated DN 40 measuring section with flange	0695 2574
VA 570 flow meter with integrated DN 50 measuring section with flange	0695 2575
VA 570 flow meter with integrated DN 65 measuring section with flange	0695 2576
VA 570 flow meter with integrated DN 80 measuring section with flange	0695 2577
Further accessories:	
Closing cap for measuring section in aluminium	0190 0001
Closing cap for measuring section stainless steel 1.4404	0190 0002
Connection cable for sensors 5 m with open ends	0553 0108
Connection cable for sensors 10 m with open ends	0553 0109
Ethernet connection cable length 5 m, M12 plug x-coded (8 poles) to RJ 45 plug	0553 2503
Ethernet connection cable length 10 m, M12 plug x-coded (8 poles) to RJ 45 plug	0553 2504
Mains unit in wall housing for maximum 2 sensors of the series VA/FA 5xx, 100-240 V, 23 VA, 50-60 Hz / 24 VDC, 0.35 A	0554 0110
ISO calibration certificate at 5 measuring points for VA sensors	3200 0001
Additional calibration point for volume flow (point freely selectable)	0700 7720
CS Service Software VA 550 incl. interface cable to PC (USB) and power supply - for configuration / parametrization of VA 550	0554 2007
PNG cable screwing - standard VA 550/570	0553 0552
PNG cable screwing - for ATEX version VA 550/570	0553 0551

TECHNICAL DATA VA 570	
Measuring range VA 570:	up to 50 Nm/s, Low Speed version* up to 92,7 Nm/s, Standard version* up to 185 Nm/s, Max version* up to 224 Nm/s, High Speed version*
	* Measuring range Nm ³ / h for different pipe diameters and gases, see table measuring ranges flow * All measurements related to DIN 1343 standard conditions 0 ° and 1013 mbar ex works
Accuracy:	± 1.5 % of m.v. ± 0.3 % of f.s.
accuracy class (m.v.: of meas. value) (f.s.: of full scale)	on request ± 1.0 % of m.v. ± 0.3 % of f.s.
Accuracy indications:	referred to ambient temperature 22 °C ± 2°C, system pressure 6 bar
Repeatability:	0.25 % of m.v. in case of correct mounting (mounting aid, position, inlet section)
Measuring principle:	Thermal mass flow sensor
Response time:	t90 < 3 s
Operating temperature range probe tube/display unit:	-40...180 °C probe tube -40...70 °C display unit -40...120 °C for ATEX version
Adjustment possibilities via display, external hand-held meter PI 500, PC Service Software, remote diagnosis:	Nm ³ /h, Nm ³ /min, NI/min, l/s, ft/min, cfm, kg/h, kg/min, inside diameter, reference conditions ° C/° F, mbar/hPa, zero point correction, low flow cut off, scaling Analog output 4 ... 20 mA, pulse/alarm, error codes etc.
Outputs:	Standard: 1 x 4 ... 20 mA analog output (not electrically isolated), pulse output, RS 485 (Modbus RTU) Optional: 2 x 4 ... 20 mA active, Modbus TCP, HART, Profibus DP, Profinet, M-Bus
Burden:	< 500 Ohm
Additional average value calculation:	for all parameters freely adjustable from 1 minute up to 1 day, e. g. 1/2 hours average value, average day value
Protection class :	IP 67
Material:	Housing aluminium die cast, probe tube stainless steel 1,4571
Operating pressure:	16 bar, in special version 40 bar
Power supply:	18...36 VDC, 5 W
Approval:	ATEX II 2G Ex d IIC T4, DVGW

Techniquip Ltd
The Old Brewery
Norton Fitzwarren
Taunton
TA2 6RN
Tel 01823-351255
eMail sales@techniquip.co.uk
www.techniquip.co.uk



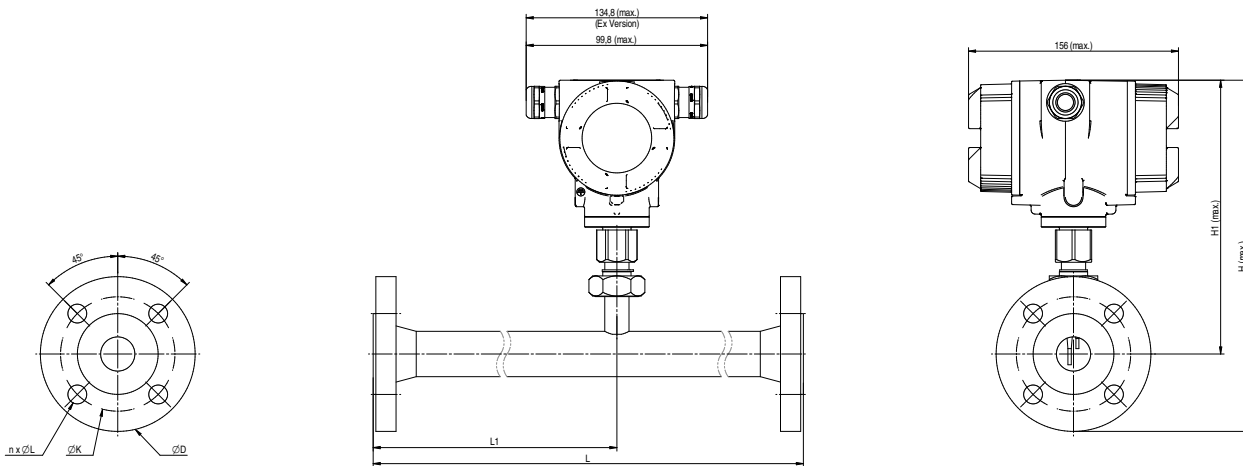

VA 570 - Flange version

Measuring section	Outer pipe diam. - mm	Inner pipe diam. - mm	L - mm	L1 - mm	H - mm	H1 - mm	Flange DIN EN 1092-1		
							Ø D	Ø K	n x Ø L
DN 15	21,3	16,1	300	210	213,2	165,7	95	65	4 x 14
DN 20	26,9	21,7	475	275	218,2	165,7	105	75	4 x 14
DN 25	33,7	27,3	475	275	223,2	165,7	115	85	4 x 14
DN 32	42,4	36,0	475	275	235,7	165,7	140	100	4 x 18
DN 40	48,3	41,9	475*	275	240,7	165,7	150	110	4 x 18
DN 50	60,3	53,1	475*	275	248,2	165,7	165	125	4 x 18
DN 65	76,1	68,9	475*	275	268,2	175,7	185	145	8 x 18
DN 80	88,9	80,9	475*	275	275,7	175,7	200	160	8 x 18

*Attention: Shortened inlet section. Please observe the recommended minimum inlet section (length = 15 x inner diameter)!

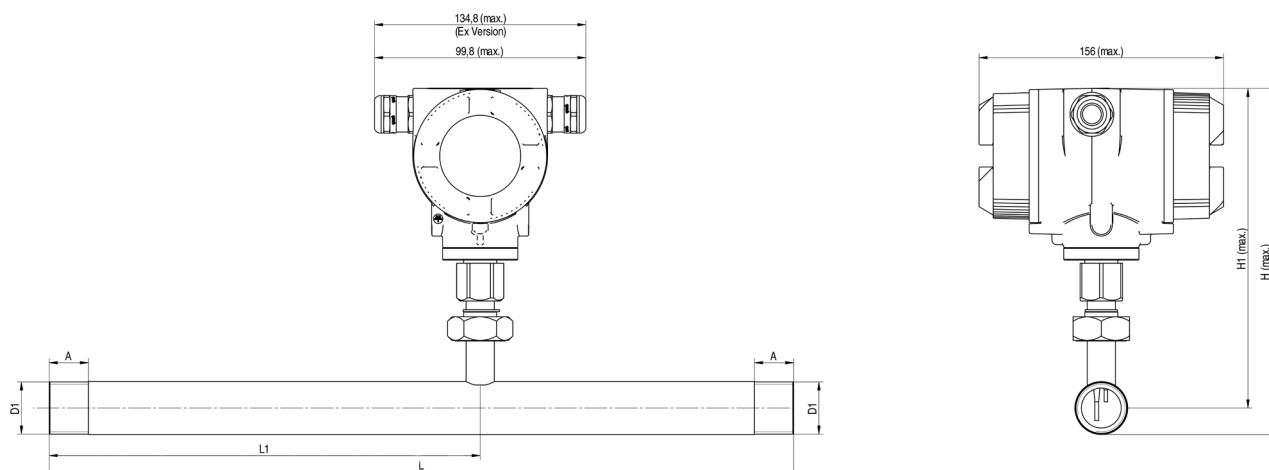

VA 570 - Threaded version

Connection thread	Outer pipe diam. - mm	Outer pipe diam. - mm	L - mm	L1 - mm	H - mm	H1 - mm	A - mm
R 1/2"	21,3	16,1	300	210	176,4	165,7	20
R 3/4"	26,9	21,7	475	275	179,2	165,7	20
R 1"	33,7	27,3	475	275	182,6	165,7	25
R 1 1/4"	42,4	36,0	475	275	186,9	165,7	25
R 1 1/2"	48,3	41,9	475*	275	186,9	165,7	25
R 2"	60,3	53,1	475*	275	195,9	165,7	30

*Attention: Shortened inlet section. Please observe the recommended minimum inlet section (length = 15 x inner diameter)!