

Liquid Soap and Sanitiser Dispensers

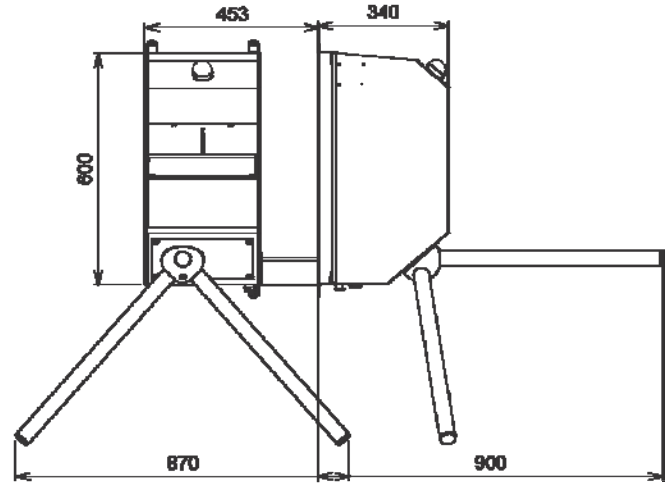

Dimensional Drawing.



2 Nozzle+turnstile unit.



1 Nozzle + Turnstile Unit



2 nozzle Unit



1 Nozzle Unit

Specifications

- 304 stainless steel construction
- Detection by infrared cell (1 or 2 depending on Model)
- Adjustable dose
- Support frame (maximum of 5 litre container)
- Removable drip tray

Power Requirement

-230 V single phase 16A

Options

Mounting Pedestal.



Guide Rail SC03715



Guide rail with sanitiser support plate SC03714



Left or Right Hand Mountable, With Free or Blocked Return

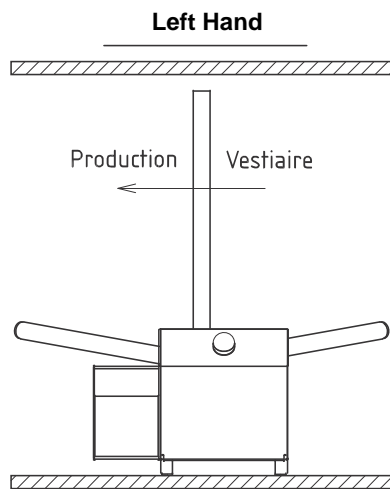
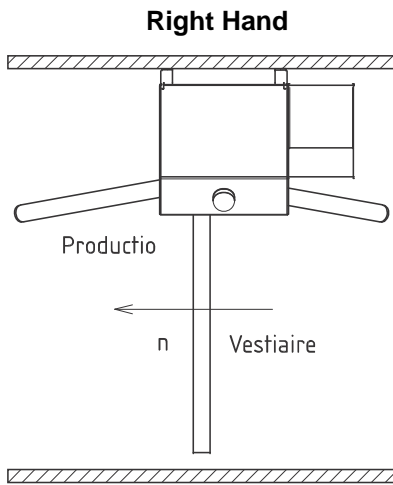

Free Return

The operative must place their hands in to the sanitiser before being allowed into the production area by the turnstile, they can then return freely to the changing room area when required

Blocked Return

The operative must place their hands in to the sanitiser before being allowed into the production area by the turnstile, their exit back to the changing area is blocked via this route

To exit the cloakroom into the production area the operative must place their hands into the sanitiser, the solution is automatically dispensed and the red light turns to green and the turnstile is activated.

Choices Flow Chart

