

• CUSTOMER SERVICE • INNOVATION • MANUFACTURING • QUALITY • TECHNICAL EXPERTISE • EXCELLENCE • DESIGN •



The Right Connection[®]

Loading Arms & Swivel Joints



Customer Service: **+44 (0)1772 323529**

Email: sales@dixoneurope.co.uk

www.dixoneurope.co.uk

Dixon Loading Arms



Loading Arm Swivels

Features:

- TTMA loading arm swivel with heavy duty D style shovel handle
- TTMA flanges on both ends
- Shovel handle is used to guide the API load coupler onto the adapter on the tank truck
- Long radius elbow improves the flow into the API load coupler and provides spacing between the load arm and the tank truck
- Can be used with flange extensions

Applications:

- used in the transfer of liquids and dry bulk in refineries, chemical plants, rail terminals, truck terminals, tote and drum filling and food industry

Sizes:

- 2", 3", 4" and more upon request

Materials:

- various materials available including: hardened carbon steel, 316L stainless steel and aluminum
- seals: Buna, EPDM, FKM A and B, PTFE, Baylast and more on request
- counterbalance housing: steel

Features:

- three options for sealing swivels: O-ring, V-ring and Split Flange
- fast delivery for many sizes and styles
- engineered with easy service in mind
- wide variety of end configurations available
- torsion spring counterbalance:
 - ball screw adjustment mechanism for easy and safe adjustment
 - multiple spring rates available for different load requirements
 - multiple grease ports for ease of service

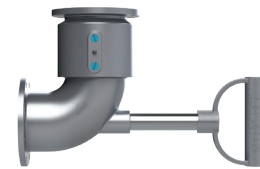

Style 30, short radius

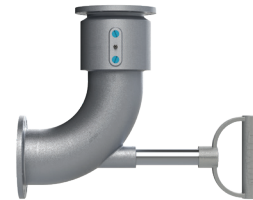

Style 30, long radius



Style 40

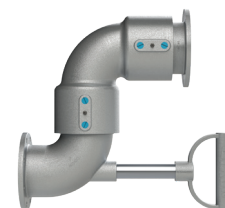

Style 50

Split Flange Swivels

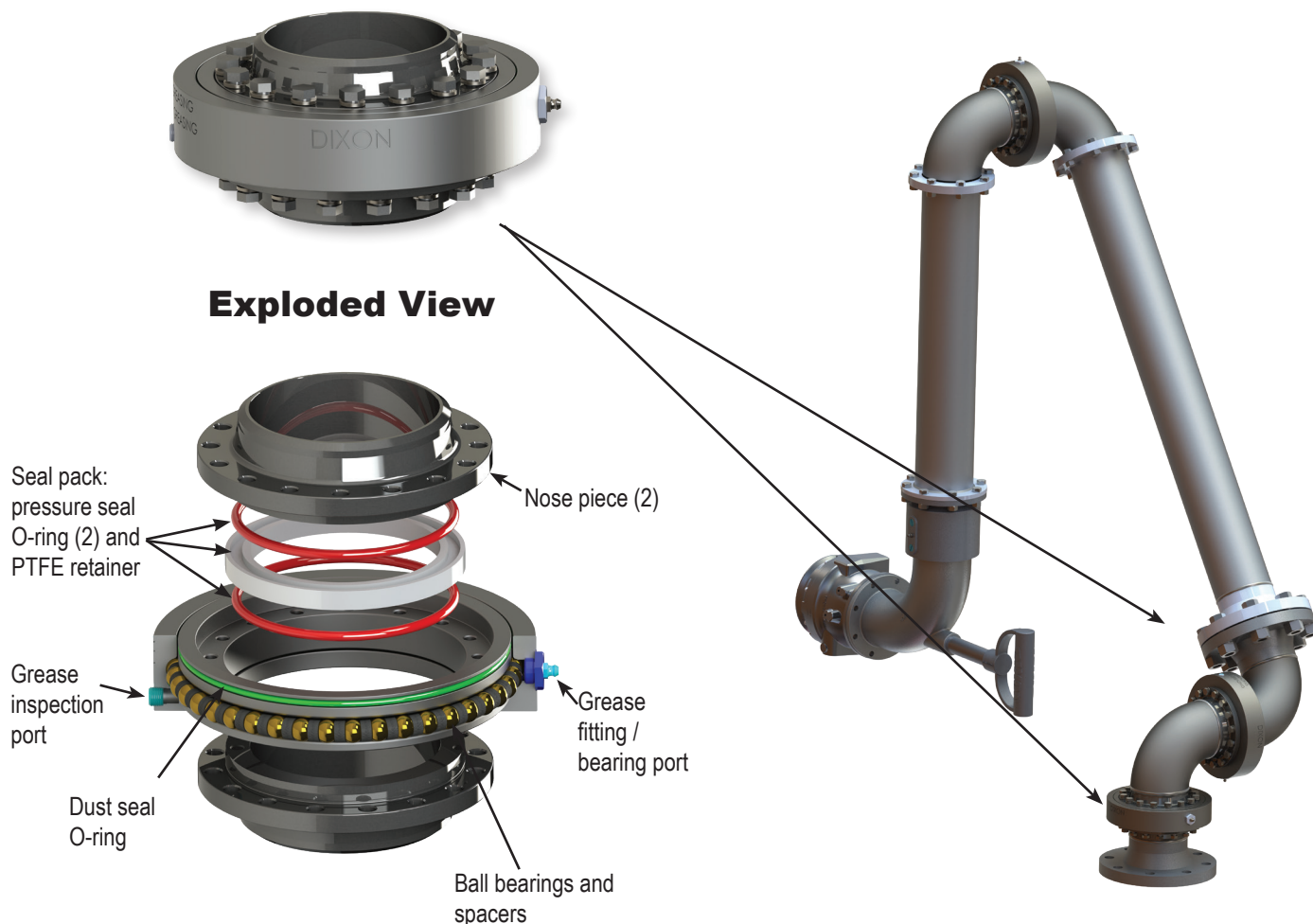

Applications:

- For use in industries from petroleum, blending plants, petrochemical, refining, mining, distilling, paint plants, farm irrigation and fertilizing, wastewater treatment, food and beverage process equipment, marine and more

Features:

- Bearing pack design allows easy seal change without removing the ball bearings.
- Simple maintenance: remove one nose piece, replace seal pack, and reinstall with little down-time.
- Instream seal separates the wetted area from the ball bearings allowing for longer bearing pack life.
- Pressure rating: up to **41 Bar (600 PSI)**
- Temperature: **-40°C to 232°C** depending on seal material (with standard seals: **176°C**)
- Wide set bearing race for higher moment loads
- Compact design for low profile applications

Materials:

- Bearing pack: through hardened forged high carbon alloy
- Material contact surfaces: stainless steel or carbon steel nose pieces

Sizes:

- 2", 3" and 4"

Available options:

- All styles
- Stock end configurations: 150 lb. and 300 lb. flanges, FNPT, butt weld, others per request
- Stock seals: Baylast™, FKM, PTFE others per request
- Full penetration weld

Swivels Joints



Applications:

- Used wherever a leak-proof swivel connection is needed in pipelines or in combination with hoses to eliminate hose twisting
- Industries range from petroleum, petrochemical, refining, mining, distilling, paint, farm irrigation and fertilizing, wastewater treatment plants and food and beverage process equipment.
- Dixon® swivel joints are found in blending plants, drum filling applications, fluid and dry bulk transfer, vacuum trucks, oil and gas trucks and water trucks. Larger swivels can be found in the steel industry, marine bulk transfer and many more.

Features:

- Full 360° rotational movement
- Wide spacing between dual ball bearing raceways ensures greater load bearing capacity
- Precision-machined design ensures alignment and trouble-free service
- O-ring dust seal protects the ball races and seals chamber from outside elements
- Radius elbow design ensures a smooth flow pattern
- Hydrostatic testing is performed on all swivels before shipment

Options Available:

- End configurations: female NPT, 150# flanges, TTMA flange, grooved, weld end and many other variations
- Seal options: Buna, FKM, PTFE, EPDM, FDA Buna, FFKM
- Ball bearing materials: carbon steel, 440 stainless steel and 316 stainless steel
- Grease materials: Lithium, FDA approved/food grade and silicone
- Swivels that include oxygen, steam or submerged service can be specifically designed for unique applications (special order)
- 100% full penetration weld
- Re-build kits
- Custom swivel options available

Online swivel configurator available online
www.dixoneurope.co.uk