



*2020 PRICE LIST / PRODUCT GUIDE*

***DIESEL STORAGE RANGE***





*FUEL PROOF LTD  
MIDDLETON BUSINESS PARK  
MIDDLETON ROAD  
HEYSHAM  
LANGASHIRE  
LA3 3FH*

*TEL: +44 (0) 1524 850685  
FAX: +44 (0) 1524 850685  
WEB: WWW.FUELPROOF.CO.UK  
E-MAIL: INFO@FUELPROOF.CO.UK*

# INFORMATION

- ▶ Details on our range of tanks and bowsers and their product codes are shown on pages 1 - 65
- ▶ Available colours and their codes are listed on **page 67**
- ▶ Pumping equipment options and codes are listed after each product range

**An example product code for a complete unit:**

1000 Litre Fuelstore (Grey) with Dispensing package 1 = **0120-020-FS010**

**0120**      **020**      **FS010**

# CONTENTS

ITEM	PAGE
● FUELCUBES	1
● FORESTRY SPEC FUELCUBES	3
● GENERATOR TANKS	7
● STATIC BUNDED FUELSTORES	11
● FUELSTORES WITH 3 POINT LINKAGE SYSTEM	13
● FORESTRY SPEC BUNDED FUELSTORES	15
● WASTE OIL TANKS	17
● HIGHWAY TOW DIESEL BOWSERS	19
● DE-MOUNTABLE IBC RANGE	21
● SITE TOW DIESEL BOWSERS - 1000 TO 2500 LITRES	23
● FUEL DISPENSING PACKAGES - FUELSTORES / HIGHWAY / DE-MOUNT / SITE	25
● SITE TOW DIESEL BOWSERS - 3000 TO 9000 LITRES	33
● BULK DIESEL TANKS - HORIZONTAL	39
● BULK DIESEL TANKS - VERTICAL	51
● OPTIONAL EQUIPMENT / ACCESSORIES	55
● HORIZONTAL BULK DIESEL TANKS WITH ADBLUE STORAGE	57
● HIGHWAY DIESEL BOWSERS WITH ADBLUE STORAGE	59
● SITE DIESEL BOWSERS WITH ADBLUE STORAGE - 4000 TO 8000 LITRES	63
● COLOUR OPTIONS	67

# STATIC BUNDED FUELCUBES

TOUGH, SECURE AND COMPACT



900 LITRE STATIC BUNDED FUELCUBE



900 LITRE STATIC BUNDED FUELCUBE

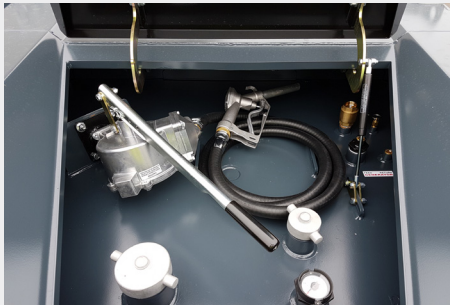

TOP VIEW OF INNER TANK SHOWING FUEL DISPENSING EQUIPMENT AND TANK CONNECTIONS

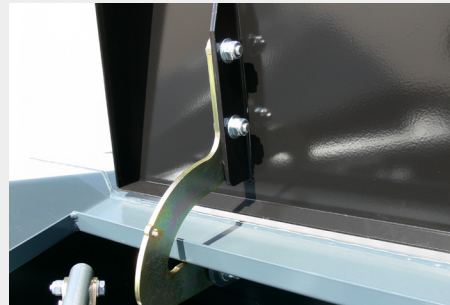

LOCKABLE LID WITH INTERNAL HINGES AND GAS STRUT ASSISTED OPENING



FUEL DISPENSING CABINET WITH ANTI-VANDAL LOCKABLE LID TO KEEP DISPENSING EQUIPMENT AND TANK INLETS/OUTLETS SECURE



4 X GALVANISED LIFTING EYES FOR EASY AND SAFE MOVING ON SITE. THESE ALSO ALLOW THE TANKS TO BE STACKED FOR EFFICIENT TRANSPORT & STORAGE

## OVERVIEW

The 250, 500 and 900 litre Fuelcubes are all well suited to a wide variety of small-to-medium scale applications. These banded diesel tanks feature an all-steel construction and are designed and manufactured in accordance with the latest regulations. The lockable lid with internal hinges and gas strut assisted opening keeps tank inlets/outlets and fuel dispensing equipment secure. The Fuelcubes are stackable and can be lifted full of fuel using the lifting eyes. Generator flow and return connections are fitted as standard.

## KEY FEATURES

- ▶ All-steel construction for unrivalled strength and security
- ▶ Compact, durable and stackable design
- ▶ UN approved for transporting diesel on the highway
- ▶ Fully banded and compliant with current environmental regulations
- ▶ Ideal for refuelling small plant and machinery, groundcare equipment, generators and traffic control equipment
- ▶ Secure lockable lid with anti-vandal door and internal hinges
- ▶ Rotary tank contents gauge
- ▶ 4 x galvanised lifting eyes and forklift pockets for safe lifting/moving
- ▶ 10 year tank warranty for peace of mind

## PRODUCT CODES / PRICES

CAPACITY	UN APPROVED	CODE
250 LITRE (55 GALLON)	✓	0010
500 LITRE (110 GALLON)	✓	0015
900 LITRE (197 GALLON)	✓	0020

Please note tank prices do not include fuel dispensing equipment

FOR FUEL DISPENSING OPTIONS PLEASE TURN TO PAGE 5

# STATIC BUNDED FUEL CUBES

TOUGH, SECURE AND COMPACT

## TECHNICAL DETAILS

CAPACITY	LENGTH (MM)	WIDTH (MM)	HEIGHT (MM)	EMPTY WEIGHT (KG)	FULL WEIGHT (KG)	MAX. HOSE LENGTH (M)	STEEL THICKNESS INNER TANK (MM)	STEEL THICKNESS OUTER TANK (MM)
250 LITRES (55 GALLONS)	784	1,024	922	265	475	3	3 & 4	3
500 LITRES (110 GALLONS)	784	1,024	1,282	320	740	3	3 & 4	3
900 LITRES (197 GALLONS)	1,016	1,220	1,362	460	1,243	5	3 & 4	3



250 LITRE



500 LITRE



900 LITRE

## STANDARD COLOUR:

ANTHRACITE GREY

RAL7016

020

For full details on colour options, codes and lead times please turn to **page 67**

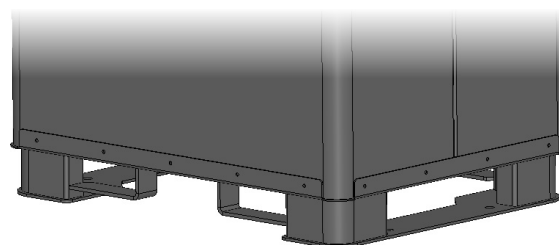

REINFORCED BASE WITH IMPROVED WEIGHT DISTRIBUTION AND TANK PROTECTION

## INNER TANK CONNECTIONS

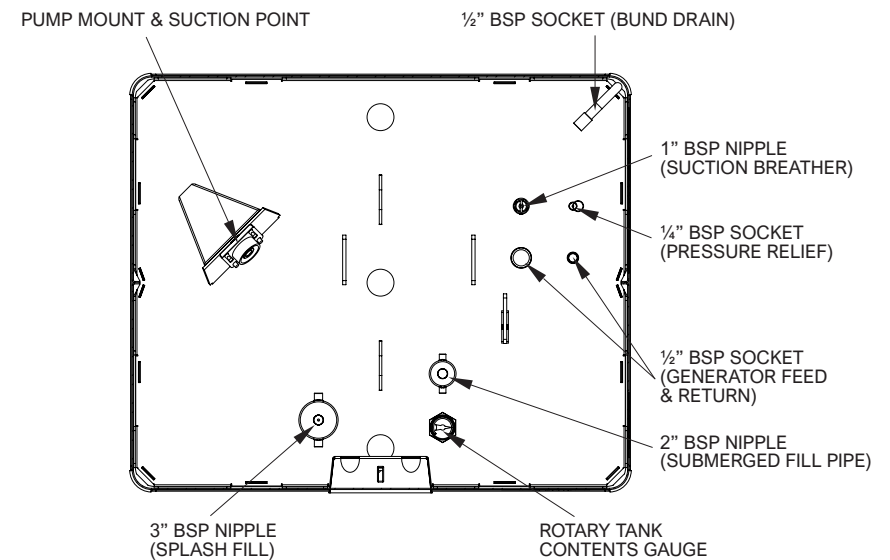

# FORESTRY SPEC BUNDED FUELCUBES

SUPER TOUGH DIESEL TANKS ADAPTED FOR USE IN FORESTRY AND AGRICULTURE



900 AND 500 LITRE FUELCUBES WITH FORESTRY SPEC

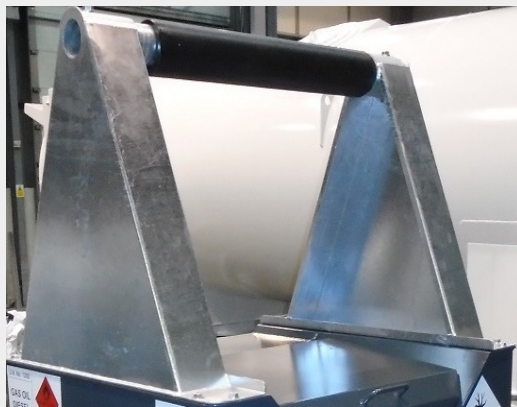

GRAB HANDLE AND BASH GUARD

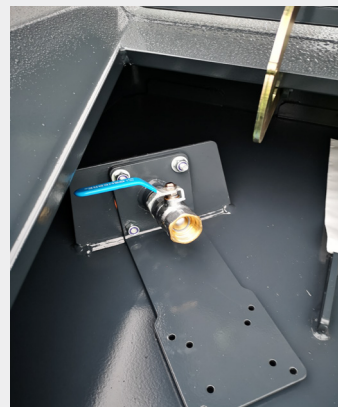

SUCTION POINT AVAILABLE ON REQUEST

## OVERVIEW

Our range of forestry specific bunded diesel tanks includes a host of innovative features tailored specifically to forestry and related applications. Constructed from steel throughout as with all Fuel Proof equipment, these units provide an extremely safe and secure solution for storing fuel. Features include a low ground steel base with integral forklift pockets, heavy duty grab handle with steel bash guard, available with either solid or hollow top bar.

## KEY FEATURES

- ▶ All-steel construction for unbeatable strength and durability
- ▶ 110% bunded and fully compliant with current environmental regulations
- ▶ Steel base with low ground pressure design and forklift pockets
- ▶ Heavy duty grab handle for lifting and moving tank with timber grabs
- ▶ Plastic protector tube (optional) when lifting with harvesting head blades
- ▶ Secure lockable lid with anti-vandal door and internal hinges
- ▶ Bash guard to provide additional protection to top of tank
- ▶ Optional solid or hollow top bar available
- ▶ Available with a range of dispensing equipment
- ▶ 3 year tank warranty for peace of mind

## PRODUCT CODES / PRICES

CAPACITY / ITEM		CODE
500 LITRE	(110 GALLON)	0124
900 LITRE	(197 GALLON)	0125
SOLID TOP BAR UPGRADE		
BLADE PROTECTOR TUBE*		2725-020

Please note tank prices do not include fuel dispensing equipment

\*Only required when tank is to be lifted/moved by machines with harvesting heads

FOR FUEL DISPENSING OPTIONS PLEASE TURN TO PAGE 5



# FORESTRY SPEC BUNDED FUELCUBES

SUPER TOUGH DIESEL TANKS ADAPTED FOR USE IN FORESTRY AND AGRICULTURE

## TECHNICAL DETAILS

CAPACITY	LENGTH (MM)	WIDTH (MM)	HEIGHT (MM)	EMPTY WEIGHT (KG)	FULL WEIGHT (KG)	MAX. HOSE LENGTH (M)	STEEL THICKNESS INNER TANK (MM)	STEEL THICKNESS OUTER TANK (MM)
500 LITRES (110 GALLONS)	784	1,024	2,091	391	819	3	3 & 4	3
900 LITRES (197 GALLONS)	1,016	1,220	2,091	511	1,302	3	3 & 4	3

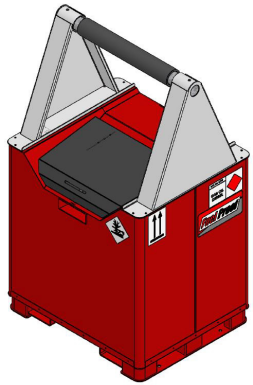

500 LITRE



900 LITRE

Standard Fuel Cubes without grab handle shown for illustrative purposes

## STANDARD COLOUR:

ANTHRACITE  
GREY

RAL7016

020

For full details on colour options, codes and lead times please turn to **page 67**

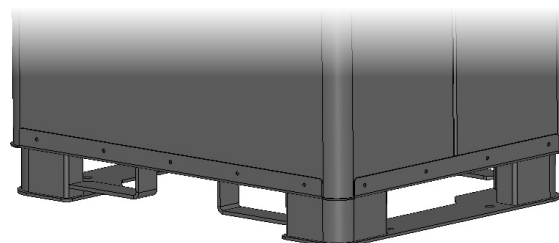

REINFORCED BASE WITH IMPROVED WEIGHT DISTRIBUTION AND TANK PROTECTION

## INNER TANK CONNECTIONS

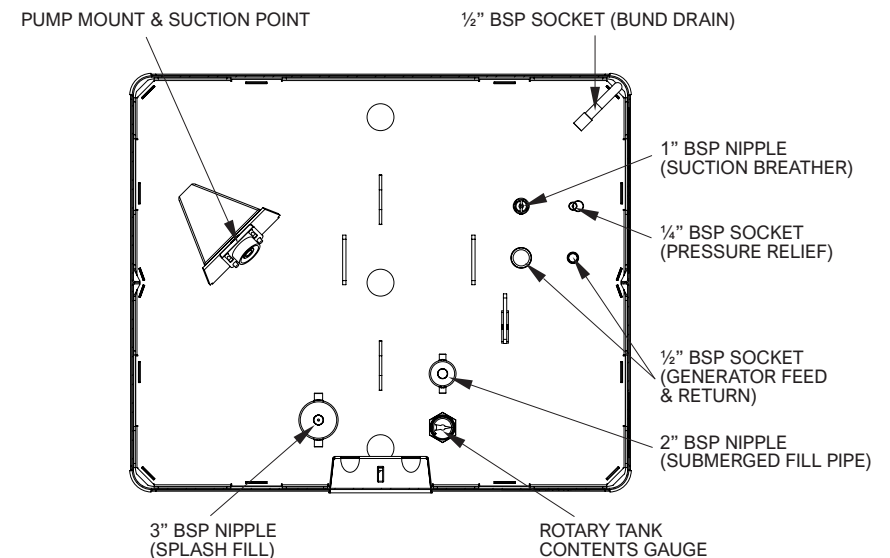

















# STATIC BUNDED FUELCUBES

TOUGH, SECURE AND COMPACT

# FUEL DISPENSING PACKAGES

HAND OPERATED, AND 12V PUMP OPTIONS









PACKAGE CODE	COMPATIBLE WITH	PUMP	HOSE	TRIGGER	FILTER	FLOW METER
<b>FC010</b>	✓ 250L ✓ 500L ✓ 900L					
		GPI HP-100 HAND PUMP 2000-040	3M X 3/4" DIESEL HOSE 2400-280	MANUAL TRIGGER 2100-080		
<b>FC012</b>	✓ 250L ✓ 500L ✓ 900L					
		GPI HP-100 HAND PUMP 2000-040	3M X 3/4" DIESEL HOSE 2400-280	MANUAL TRIGGER 2100-080	PARTICLE FILTER 2300-050	K24 DIGITAL FLOW METER 2200-010
<b>FC050</b>	✓ 250L ✓ 500L ✓ 900L					
		12/24V 50L/MIN PUMP 2001-500	3M X 3/4" DIESEL HOSE 2400-280	AUTO SHUT-OFF TRIGGER 2150-100		
<b>FC051</b>	✓ 250L ✓ 500L ✓ 900L					
		12/24V 50L/MIN PUMP 2001-500	3M X 3/4" DIESEL HOSE 2400-280	AUTO SHUT-OFF TRIGGER 2150-100	PARTICLE FILTER 2300-050	K24 DIGITAL FLOW METER 2200-010

# FUEL DISPENSING PACKAGES

230V PUMP OPTIONS

# STATIC BUNDED FUELCUBES

TOUGH, SECURE AND COMPACT

PACKAGE CODE	COMPATIBLE WITH	PUMP	HOSE	TRIGGER	FILTER	FLOW METER
<b>FC090</b>	<ul style="list-style-type: none"> <li>✓ 250L</li> <li>✓ 500L</li> <li>✓ 900L</li> </ul>					
		56L/MIN 230V PUMP 2020-040	3M X 1" DIESEL HOSE 2400-285	AUTO SHUT-OFF TRIGGER 2150-100		
<b>FC091</b>	<ul style="list-style-type: none"> <li>✓ 250L</li> <li>✓ 500L</li> <li>✓ 900L</li> </ul>					
		56L/MIN 230V PUMP 2020-040	3M X 1" DIESEL HOSE 2400-285	AUTO SHUT-OFF TRIGGER 2150-100	PARTICLE FILTER 2300-050	K24 DIGITAL FLOW METER 2200-010

# BUNDED GENERATOR TANKS

SUPER TOUGH, RELIABLE AND VERSATILE



STACKABLE DESIGN MAKES GENERATOR TANKS IDEAL FOR TRANSPORTING AND STORING

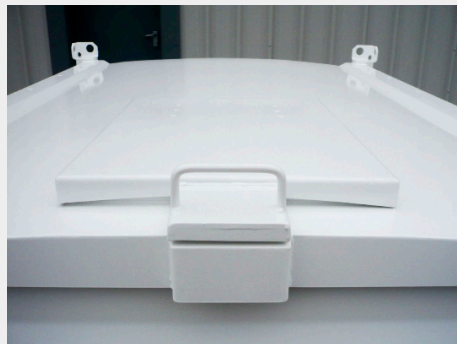

LOCKABLE LID WITH ANTI-VANDAL LOCK COVER AND GAS STRUT OPENING. KEEPS DISPENSING EQUIPMENT AND TANK INLETS/OUTLETS SECURE



MULTIPLE GENERATOR FEED AND RETURN CONNECTIONS FOR A WIDE RANGE OF APPLICATIONS

## OVERVIEW

In developing our range of bundled generator supply tanks we have focused on producing a tough, user-friendly product that provides excellent value for money. With a compact and stackable design, the tanks can be used in a wide variety of applications. Constructed from 3mm & 4mm steel, the tanks are extremely tough and are built to withstand heavy use.

## KEY FEATURES

- ▶ Heavy duty design with all-steel construction
- ▶ UN approved for transporting diesel on the highway
- ▶ Fully compliant with current environmental regulations
- ▶ 3 pairs of generator feed & return connections
- ▶ Compact and stackable design for efficient transporting & storage
- ▶ 4 x lifting eyes and forklift pockets for safe and easy lifting / moving
- ▶ Secure lid with anti-vandal padlock cover and gas strut opening
- ▶ 10 year warranty for peace of mind

## PRODUCT CODES / PRICES

CAPACITY	UN APPROVED	CODE
1,000 LITRE (220 GALLON)	✓	0030
2,000 LITRE (330 GALLON)	✓	0035
3,000 LITRE (440 GALLON)	✓	0040

Please note tank prices do not include fuel dispensing equipment

FOR FUEL DISPENSING OPTIONS PLEASE TURN TO PAGE 9

# BUNDED GENERATOR TANKS

SUPER TOUGH, RELIABLE AND VERSATILE

## TECHNICAL DETAILS

CAPACITY	LENGTH (MM)	WIDTH (MM)	HEIGHT (MM)	EMPTY WEIGHT (KG)	FULL WEIGHT (KG)	MAX. HOSE LENGTH (M)	STEEL THICKNESS INNER TANK (MM)	STEEL THICKNESS OUTER TANK (MM)
1,000 LITRES (220 GALLONS)	1,262	1,262	1,300	470	1,320	3	3	3
2,000 LITRES (440 GALLONS)	2,315	1,262	1,300	725	2,425	3	3	3
3,000 LITRES (660 GALLONS)	2,315	1,705	1,300	865	3,475	3	3	3



1,000 LITRE



2,000 LITRE



3,000 LITRE

## STANDARD COLOUR:

ANTHRACITE  
GREY

RAL7016

020

For full details on colour options, codes and lead times please turn to **page 67**



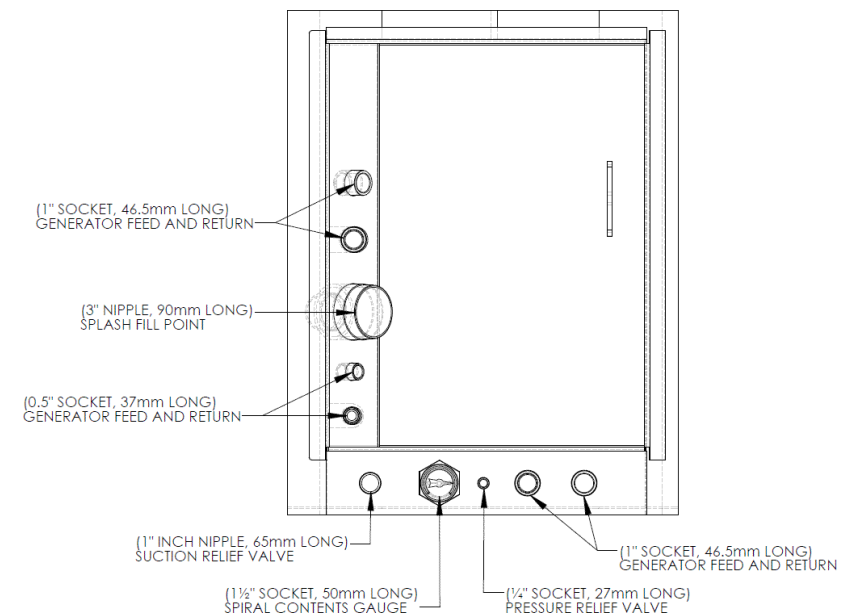



## INNER TANK CONNECTIONS



# BUNDED GENERATOR TANKS

SUPER TOUGH, RELIABLE AND VERSATILE

# FUEL DISPENSING PACKAGES

PACKAGE CODE	PUMP	HOSE	TRIGGER	FILTER		
<b>GT010</b>						
	12/24V 50L/MIN PUMP 2001-500	3M X 3/4" DIESEL HOSE 2400-280	AUTO SHUT-OFF TRIGGER 2150-100			
<b>GT011</b>						
	12/24V 50L/MIN PUMP 2001-500	3M X 3/4" DIESEL HOSE 2400-280	AUTO SHUT-OFF TRIGGER 2150-100	PARTICLE FILTER 2300-050		



# STATIC BUNDED FUELSTORES

UNBEATABLE SECURITY, DURABILITY AND VALUE

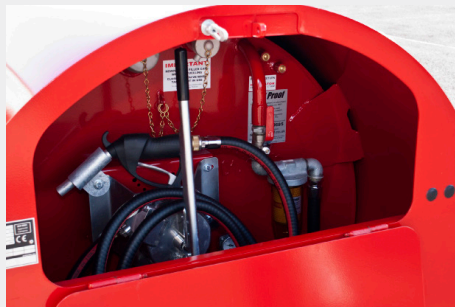

LOCKABLE CABINET KEEPS DISPENSING EQUIPMENT AND TANK INLETS/OUTLETS SECURE



GALVANISED TUBULAR STEEL BASE WITH INTEGRAL FORKLIFT POCKETS FOR EASY LIFTING & MOVING



4 X HEAVY DUTY LIFTING EYES FOR LIFTING AND MOVING SAFELY ON SITE



EASY TO LIFT AND MOVE SAFELY ON SITE

## OVERVIEW

Our industry leading Fuelstore range are the toughest and most secure banded fuel tanks on the market. Constructed from steel throughout and fully compliant with current environmental regulations, these tanks provide unbeatable security, durability and value for money.

## KEY FEATURES

- ▶ The strongest and most secure diesel tanks on the market
- ▶ UN approved for transporting fuel on the highway (*500L-2500L models only\**)
- ▶ Fully compliant with current environmental regulations
- ▶ Lockable door with anti-vandal padlock cover
- ▶ Heavy duty galvanised steel base with integral forklift pockets
- ▶ All-steel construction for long term reliable service
- ▶ 10 year warranty for peace of mind

## PRODUCT CODES / PRICES

CAPACITY		UN APPROVED	CODE
500 LITRE	(110 GALLON)	✓	0110
1,000 LITRE	(220 GALLON)	✓	0120
1,500 LITRE	(330 GALLON)	✓	0130
2,000 LITRE	(440 GALLON)	✓	0140
2,500 LITRE	(550 GALLON)	✓	0150
3,000 LITRE*	(660 GALLON)	✗	0160
4,500 LITRE*	(1,000 GALLON)	✗	0170

Please note tank prices do not include fuel dispensing equipment

\* 3000 and 4500 litre Fuelstores cannot be transported on the highway if they contain any fuel

FOR FUEL DISPENSING OPTIONS PLEASE TURN TO PAGE 25



# STATIC BUNDED FUELSTORES

UNBEATABLE SECURITY, DURABILITY AND VALUE

## TECHNICAL DETAILS

CAPACITY	LENGTH (MM)	WIDTH (MM)	HEIGHT (MM)	EMPTY WEIGHT (KG)	FULL WEIGHT (KG)	MAX. HOSE LENGTH (M)	CABINET DEPTH (MM)	STEEL THICKNESS INNER TANK (MM)	STEEL THICKNESS OUTER TANK (MM)
500 LITRES (110 GALLONS)	1,327	1,072	1,278	450	885	6*	450	3	3
1,000 LITRES (220 GALLONS)	1,587	1,309	1,506	595	1,465	6*	470	3	3
1,500 LITRES (330 GALLONS)	2,087	1,309	1,507	699	2,085	6*	470	3	3
2,000 LITRES (440 GALLONS)	2,087	1,489	1,712	820	2,620	6*	470	3	4
2,500 LITRES (550 GALLONS)	2,597	1,489	1,712	1,000	3,225	12	650	3	4
3,000 LITRES (660 GALLONS)	2,597	1,584	1,835	1,210	3,984	12	650	3	4
4,500 LITRES (1,000 GALLONS)	2,837	1,979	1,958	1,499	5,416	12	610	4	4

\* Extended cabinet option is available if longer hose length is required (see page 32)



500 LITRE



1,000 LITRE



1,500 LITRE



2,000 LITRE



2,500 LITRE



3,000 LITRE



4,500 LITRE

### STANDARD COLOUR

ANTHRACITE  
GREY 020  
RAL7016

For full details on colour options, codes and lead times please turn to page 67

### INNER TANK CONNECTIONS

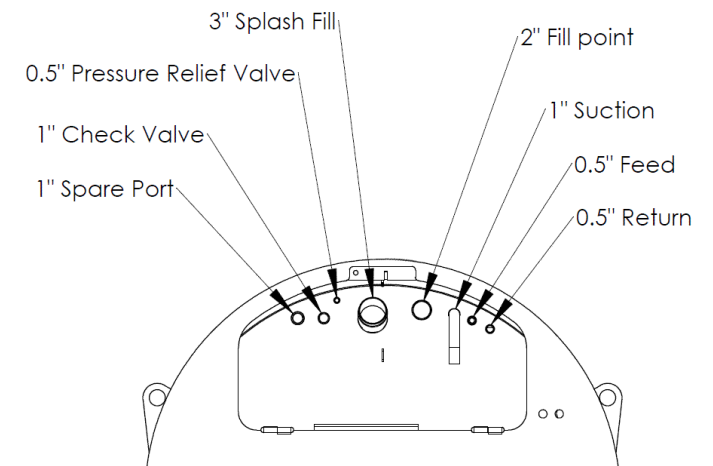

# FUELSTORES WITH 3 POINT LINKAGE SYSTEM

VERSATILE, SECURE AND SUPER TOUGH



500 LITRE FUELSTORE WITH 3 POINT LINKAGE SYSTEM



TANK CAN BE LIFTED AND MOVED EASILY BY ANY MACHINE WITH 3 POINT LINKAGE



CENTRAL LIFTING EYE PROVIDES ADDITIONAL OPTION FOR LIFTING AND MOVING TANK

## OVERVIEW

Available on our 500, 1,000 and 1,500 litre Fuelstores. The 3 point linkage frame enables tractors and other machinery to lift and move our Fuelstores quickly and safely. The linkage system offers increased flexibility and efficiency for a wide range of applications, including agriculture, forestry, construction and industrial.

## KEY FEATURES

- ▶ Heavy duty 3 point linkage frame enables tank to be lifted and moved easily by any vehicle with a 3 point linkage
- ▶ Tank can also be lifted and moved using the forklift pockets, central lift eye and 4 x lifting eyes on side of tank
- ▶ 110% bunded tank in accordance with environmental regulations
- ▶ Steel frame also provides additional protection to tank
- ▶ Secure lockable door with anti-vandal lock cover
- ▶ UN approved for transporting diesel on the highway
- ▶ 10 year warranty for peace of mind

## PRODUCT CODES / PRICES

CAPACITY		UN APPROVED	CODE
500 LITRE	(110 GALLON)	✓	0111
1,000 LITRE	(220 GALLON)	✓	0121
1,500 LITRE	(330 GALLON)	✓	0131

Please note tank prices do not include fuel dispensing equipment

# FUELSTORES WITH 3 POINT LINKAGE SYSTEM

VERSATILE, SECURE AND SUPER TOUGH

## TECHNICAL DETAILS

CAPACITY	LENGTH (MM)	WIDTH (MM)	HEIGHT (MM)	EMPTY WEIGHT (KG)	FULL WEIGHT (KG)	MAX. HOSE LENGTH (M)	CABINET DEPTH (MM)	STEEL THICKNESS INNER TANK (MM)	STEEL THICKNESS OUTER TANK (MM)
500 LITRE (110 GALLON)	1,327	1,534	1,509	550	985	6*	450	3	3
1,000 LITRE (220 GALLON)	1,577	1,654	1,706	695	1,565	6*	468	3	3
1,500 LITRE (330 GALLON)	2,078	1,706	1,654	799	2,185	6*	480	3	3

\* Extended cabinet option is available if longer hose length is required (see page 32)



## INNER TANK CONNECTIONS

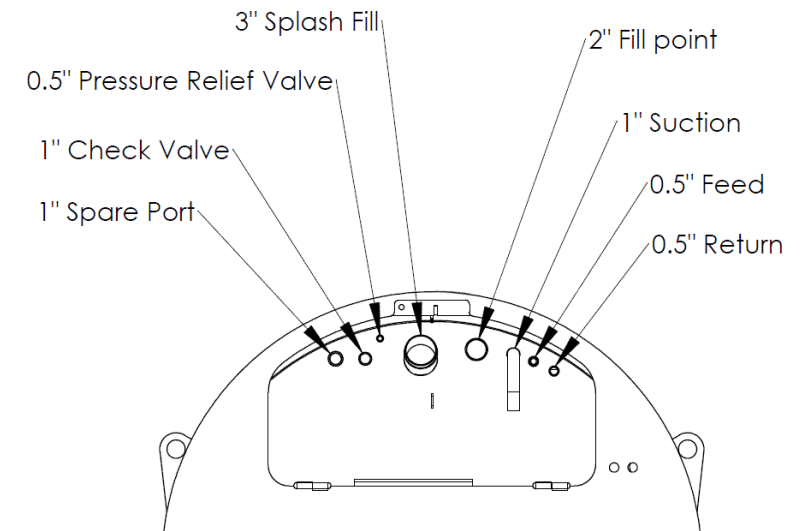

## STANDARD COLOUR

ANTHRACITE  
GREY 020  
RAL7016

For full details on colour options, codes and lead times please turn to **page 67**

# FORESTRY SPEC BUNDED FUELSTORES

## SUPER TOUGH DIESEL TANKS ADAPTED FOR USE IN FORESTRY & AGRICULTURE



1,000 AND 1,500 LITRE FUELSTORES WITH FORESTRY SPEC



ALL MODELS FEATURE LOCKABLE FUEL DISPENSING CABINET WITH FOLD DOWN DOOR



LOW GROUND PRESSURE SKID BASE



GRAB HANDLE AND BASH GUARD



1000 LITRE MODEL AVAILABLE WITH DRUM STORAGE CABINET FOR STORING OIL DRUMS, TOOLS ETC.

## OVERVIEW

Our range of forestry specific bunded diesel tanks includes a host of innovative features tailored specifically to forestry and related applications. Constructed from steel throughout as with all Fuel Proof equipment, these units provide an extremely safe and secure solution for storing fuel. Features include a low ground pressure galvanised steel base with integral forklift pockets, heavy duty grab handle with steel bash guard, plus optional drum store (*1000 litre model only*).

## KEY FEATURES

- ▶ All-steel construction for unbeatable strength and durability
- ▶ 110% bunded and fully compliant with current environmental regulations
- ▶ Galvanised steel base with low ground pressure design and forklift pockets
- ▶ Heavy duty grab handle for lifting and moving tank with timber grabs
- ▶ Plastic protector tubes (optional) when lifting with harvesting head blades
- ▶ Bash guard to provide additional protection to top of tank
- ▶ Lockable fuel dispensing cabinet with fold down door and anti-vandal cover
- ▶ Optional drum storage cabinet with mesh floor & storage shelves (*1000L model only*)
- ▶ Available with a range of dispensing equipment to suit your requirements
- ▶ 10 year warranty for peace of mind

## PRODUCT CODES / PRICES

CAPACITY / ITEM	UN APPROVED	CODE
1,000 LITRE (220 GALLON)	✓	0124
1,000 LITRE (220 GALLON) WITH DRUM STORAGE CABINET	✓	0125
1,500 LITRE (330 GALLON)	✓	0135
BLADE PROTECTOR TUBES*		2725-020

Please note tank prices do not include fuel dispensing equipment

\* Only required when tank is to be lifted/moved by machines with harvesting heads

FOR FUEL DISPENSING OPTIONS PLEASE TURN TO PAGE 25

# FORESTRY SPEC BUNDED FUELSTORES

SUPER TOUGH DIESEL TANKS ADAPTED FOR USE IN FORESTRY & AGRICULTURE

## TECHNICAL DETAILS

CAPACITY	LENGTH (MM)	WIDTH (MM)	HEIGHT (MM)	EMPTY WEIGHT (KG)	FULL WEIGHT (KG)	MAX. HOSE LENGTH (M)	CABINET DEPTH (MM)	STEEL THICKNESS INNER TANK (MM)	STEEL THICKNESS OUTER TANK (MM)
1,000 LITRE (220 GALLON)	1,930	1,388	2,115	1,250	2,110	6	470	3 & 4	3 & 4
1,000 LITRE (220 GALLON) WITH DRUM STORAGE CABINET	2,430	1,388	2,115	1,366	2,226	6	510 / 510	3 & 4	3 & 4
1,500 LITRE (330 GALLON)	2,430	1,388	2,115	1,400	2,260	6	480	3 & 4	3 & 4



1500 LITRE FORESTRY SPEC  
BUNDED FUELSTORE



1000 LITRE FORESTRY SPEC  
BUNDED FUELSTORE



1000 LITRE FORESTRY SPEC  
BUNDED FUELSTORE WITH  
DRUM STORE (OPTIONAL)

## STANDARD COLOUR:

ANTHRACITE  
GREY

RAL7016

020

For full details on colour options, codes and lead times please turn to [page 67](#)

## INNER TANK CONNECTIONS

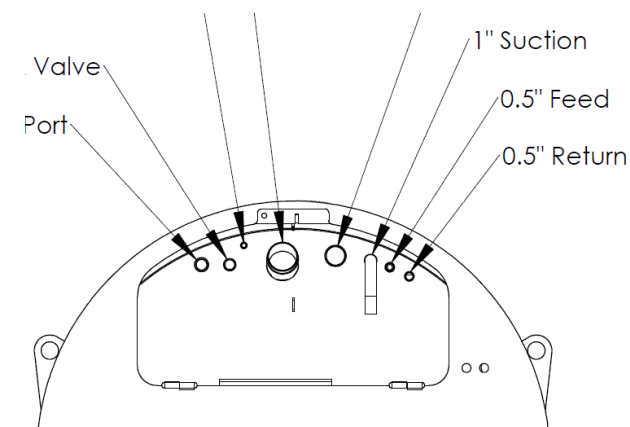

# WASTE OIL SPEC BUNDED FUELSTORES

SUPER TOUGH DIESEL TANKS ADAPTED FOR USE WITH WASTE OIL



1,000 AND 1,500 LITRE FUELSTORES WITH FORESTRY SPEC



SAFE STEP ACCESS POINT TO MANWAY FILLING POINT



LOW GROUND PRESSURE SKID BASE

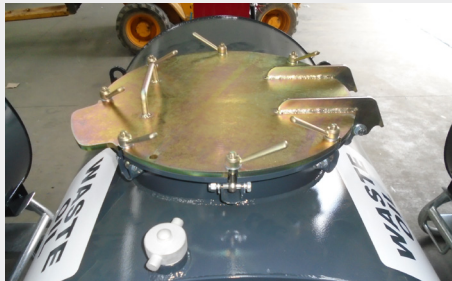

MANWAY FILLING POINT WITH SECURING POINTS AS STANDARD



ALL MODELS AVAILABLE WITH MESH STRAINER SYSTEM TO AVOID OBJECTS ENTERING TANK

## OVERVIEW

Our range of waste oil specific bunded tanks includes a host of innovative features tailored specifically to waste oil storage and related applications. Constructed from steel throughout as with all Fuel Proof equipment, these units provide an extremely safe and secure solution for storing waste oil. Features include a low ground pressure galvanised steel base with integral forklift pockets, manway access point with steel securing pegs, plus safe access step and bund drain access point.

## KEY FEATURES

- ▶ All-steel construction for unbeatable strength and durability
- ▶ 110% bunded and fully compliant with current environmental regulations
- ▶ Galvanised steel base with low ground pressure design and forklift pockets
- ▶ Manway access pouring point with safe access step system
- ▶ Lockable manway access point
- ▶ Optional bund alarm available on request
- ▶ Oil transfer pump kit available on request
- ▶ 3 year warranty for peace of mind

## PRODUCT CODES / PRICES

CAPACITY	UN APPROVED	CODE
1,400 LITRE (308 GALLON)	✓	0910
2,500 LITRE (550 GALLON)	✓	0915

Please note tank prices do not include fuel dispensing equipment

# WASTE OIL SPEC BUNDED FUELSTORES

SUPER TOUGH DIESEL TANKS ADAPTED FOR USE WITH WASTE OIL

## TECHNICAL DETAILS

CAPACITY	LENGTH (MM)	WIDTH (MM)	HEIGHT (MM)	EMPTY WEIGHT (KG)	FULL WEIGHT (KG)	MAX. HOSE LENGTH (M)	CABINET DEPTH (MM)	STEEL THICKNESS INNER TANK (MM)	STEEL THICKNESS OUTER TANK (MM)
1,400 LITRE (308 GALLON)	2,087	1,309	1,607	597	1,894	N/A	N/A	3 & 4	3 & 4
2,500 LITRE (550 GALLON)	2,597	1,489	1,812	913	3,029	N/A	N/A	3 & 4	3 & 4



1400 LITRE WASTE OIL SPEC BUNDED FUELSTORE

## STANDARD COLOUR:

For full details on colour options, codes and lead times please turn to [page 67](#)

ANTHRACITE  
GREY

RAL7016

020



2500LITRE WASTE OIL SPEC BUNDED FUELSTORE

# HIGHWAY TOW DIESEL BOWSERS

THE INDUSTRY STANDARD FOR TRANSPORTING FUEL



1,000 LITRE SINGLE AXLE HIGHWAY BOWSER

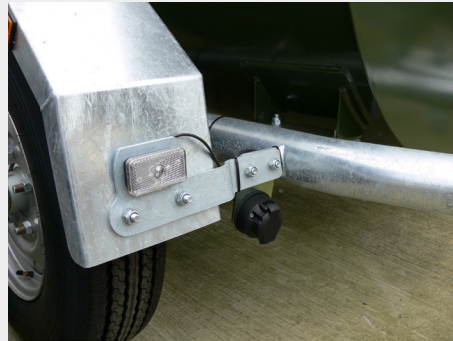

SIDE REFLECTOR AND TRAILER LIGHTING CONNECTION



LOCKABLE FUEL DISPENSING CABINET



HEAVY DUTY GALVANISED MUDGUARDS



HEAVY DUTY RUNNING GEAR



HIGH STRENGTH GALVANISED TUBULAR STEEL CHASSIS WITH HIGHWAY COMPLIANT LIGHTING

## OVERVIEW

Fuel Proof's range of highway towable diesel bowzers are the most innovative, secure and durable products of their type on the market. Reliable, secure and built to last, these units are fully U.N. approved for transporting diesel on the highway. The baffled inner tank ensures excellent stability on the move, and the high quality running gear ensures years of trouble free service.

## KEY FEATURES

- ▶ UN approved for transporting diesel on the highway
- ▶ Fully compliant with current environmental regulations
- ▶ Highway compliant LED Lighting
- ▶ Steel tank and heavy-duty galvanised tubular steel chassis makes these units the strongest and most durable on the market
- ▶ Galvanised mudguards for strength and durability
- ▶ Secure lockable door with anti-vandal padlock cover
- ▶ High quality running gear for years of trouble free service

## PRODUCT CODES / PRICES

CAPACITY	AXLES	UN APPROVED	CODE
500 LITRE (110 GALLON)	SINGLE	✓	0305
1,000 LITRE (220 GALLON)	SINGLE	✓	0310
1,000 LITRE (220 GALLON)	TWIN	✓	0320
2,000 LITRE (440 GALLON)	TWIN	✓	0330

Please note bowser prices do not include fuel dispensing equipment

FOR FUEL DISPENSING OPTIONS PLEASE TURN TO PAGE 25



# HIGHWAY TOW DIESEL BOWSERS

THE INDUSTRY STANDARD FOR TRANSPORTING FUEL

## TECHNICAL DETAILS

CAPACITY	AXLES	LENGTH (MM)	WIDTH (MM)	HEIGHT (MM)	EMPTY WEIGHT (KG)	FULL WEIGHT (KG)	MAX. HOSE LENGTH (M)	CABINET DEPTH (MM)	STEEL THICKNESS INNER TANK (MM)	STEEL THICKNESS OUTER TANK (MM)
500 LITRES (110 GALLONS)	SINGLE	2,895	1,744	1,495	495	945	6*	450	3	3
1,000 LITRES (220 GALLONS)	SINGLE	3,175	1,815	1,683	640	1,500	6*	468	3	3
1,000 LITRES (220 GALLONS)	TWIN	3,175	1,760	1,568	740	1,590	6*	480	3	3
2,000 LITRES (440 GALLONS)	TWIN	3,838	1,819	1,895	1,235	2,835	6*	460	3	4

\* Extended cabinet option is available if longer hose length is required (see page 32)



### INNER TANK CONNECTIONS

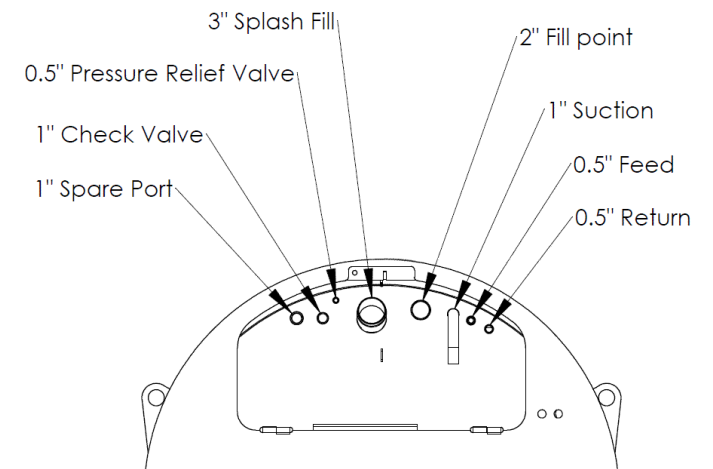

## STANDARD COLOUR:

ANTHRACITE GREY

RAL7016

020

For full details on colour options, codes and lead times please turn to **page 67**

# DE-MOUNTABLE IBC RANGE

THE INDUSTRY STANDARD FOR TRANSPORTING FUEL



1,000 LITRE DE-MOUNT IBC'S STACKED ON HIGHWAY TOWABLE CHASSIS (TOOLBOX OPTIONAL)



TOP MOUNTED FORKLIFT POCKET OPTION FOR SAFE AND EASY LIFTING AND MOVING OF TANKS

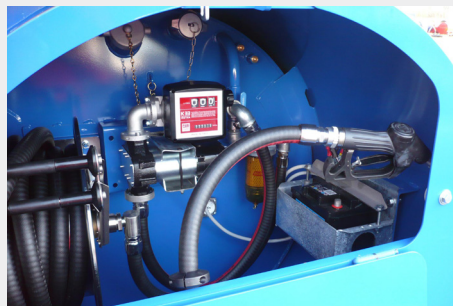

EXTENDED CABINET OPTION WITH HOSE REEL, FLOW METER, HIGH FLOW 12V PUMP WITH BATTERY, AND AUTOMATIC SHUT-OFF TRIGGER (OPTIONAL)

## OVERVIEW

Fuel Proof's range of De-mountable IBC's takes the industry leading Fuelstore concept a stage further, with a range of 1,000 litre units available in six different configurations to suit your specific requirements - making your fuel storage and refuelling operation even more efficient. The range includes a twin axle towable chassis for transporting the units on the road.

## KEY FEATURES

- ▶ UN approved for transporting diesel on the highway
- ▶ Fully compliant with current environmental regulations
- ▶ Steel tank and heavy duty galvanised tubular steel chassis make these units the strongest and most durable on the market
- ▶ Stackable design ideal for transportation and storage
- ▶ 10 year warranty for peace of mind

## PRODUCT CODES / PRICES

CONFIGURATION	CODE
DE-MOUNT IBC	0122-050
DE-MOUNT IBC WITH EXTENDED CABINET*	0122-100
DE-MOUNT IBC WITH TOP BRACKETS	0122-150
DE-MOUNT IBC WITH EXTENDED CABINET & TOP BRACKETS*	0122-200
DE-MOUNT IBC WITH TOP BRACKETS & FORKLIFT POCKETS	0122-250
DE-MOUNT IBC WITH EXTENDED CABINET, TOP BRACKETS & FORK. POCKETS*	0122-300
TRAILER FOR 1000L DE-MOUNT IBC - 50MM BALL / 40MM RING	0122-500/505

Please note bowser prices do not include fuel dispensing equipment

\* Price includes spring rewind hose reel

## TECHNICAL DETAILS

CONFIGURATION	LENGTH (MM)	WIDTH (MM)	HEIGHT (MM)	EMPTY WEIGHT (KG)	FULL WEIGHT (KG)	MAX. HOSE LENGTH (M)	STEEL THICKNESS INNER TANK (MM)	STEEL THICKNESS OUTER TANK (MM)
DE-MOUNT IBC	1,608	1,248	1,473	483	1,343	6	3	3
DE-MOUNT IBC WITH EXTENDED CABINET	1,863	1,263	1,473	547	1,408	12	3	3
DE-MOUNT IBC WITH TOP BRACKETS	1,608	1,248	1,473	483	1,343	6	3	3
DE-MOUNT IBC WITH EXTENDED CABINET & TOP BRACKETS	1,863	1,263	1,473	547	1,408	12	3	3
DE-MOUNT IBC WITH TOP BRACKETS & FORKLIFT POCKETS	1,608	1,248	1,473	483	1,343	6	3	3
DE-MOUNT IBC WITH EXT. CABINET, TOP BRACKETS & FORK. POCKETS	1,863	1,263	1,473	547	1,408	12	3	3

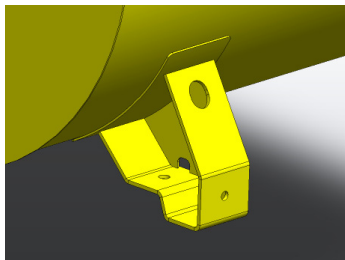

DEMOUNT TANK FEET

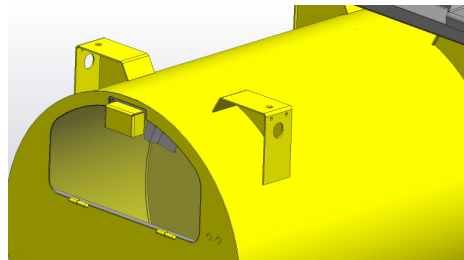

TOP BRACKETS

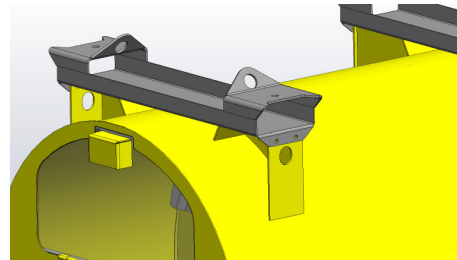

TOP BRACKETS AND FORKLIFT POCKETS

### INNER TANK CONNECTIONS

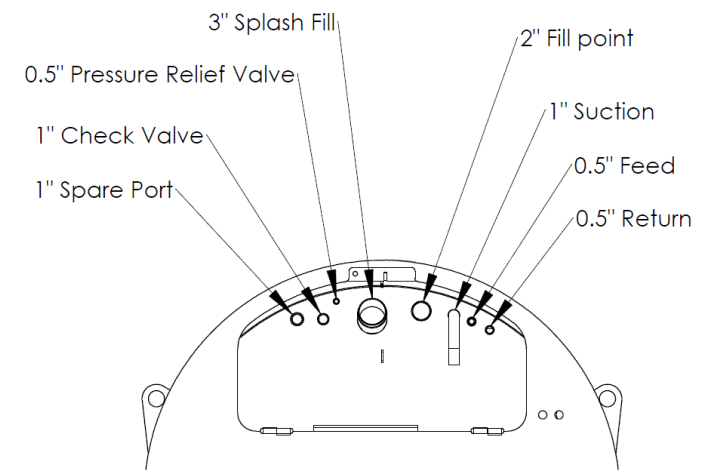

## STANDARD COLOUR:

ANTHRACITE  
GREY

RAL7016

020

For full details on colour options, codes and lead times please turn to **page 67**

# SITE TOW DIESEL BOWSERS - 1000 TO 2500 LITRES

THE TOUGHEST SITE TOW BOWSERS ON THE MARKET



1,000 LITRE SITE TOW DIESEL BOWSER



LOCKABLE FUEL DISPENSING CABINET WITH FOLD DOWN DOOR



REINFORCED GALVANISED TUBULAR STEEL CHASSIS FOR EXTRA STRENGTH AND DURABILITY



FLOTATION TYRES FOR ROUGH TERRAIN



HEAVY DUTY AXLES, WHEELS AND TYRES



HEAVY DUTY TOWING HITCH

## OVERVIEW

The Fuel Proof range of bunded site tow bowzers combines safe, secure fuel storage with on-site mobility. Both the inner and outer tanks are constructed from steel throughout, with a 110% bund capacity in accordance with the PPG2 Pollution Prevention guidelines. Heavy duty reinforced galvanised tubular steel chassis is extremely strong and durable. Flotation tyres ideal for off-road use.

## KEY FEATURES

- ▶ The toughest site towable bowzers on the market
- ▶ Fully compliant with current environmental regulations
- ▶ All-steel construction for strength and durability
- ▶ Reinforced, heavy duty galvanised tubular steel chassis
- ▶ Tough site specification with heavy duty running gear
- ▶ Baffled inner tank for increased stability when in transit
- ▶ 10 year warranty for peace of mind

## PRODUCT CODES / PRICES

CAPACITY	UN APPROVED	CODE
1,000 LITRE (220 GALLON)	✓	0410
2,000 LITRE (440 GALLON)	✓	0420
2,500 LITRE (550 GALLON)	✓	0430

Please note bowser prices do not include fuel dispensing equipment

FOR FUEL DISPENSING OPTIONS PLEASE TURN TO PAGE 25

# SITE TOW DIESEL BOWSERS - 1000 TO 2500 LITRES

THE TOUGHEST SITE TOW BOWSERS ON THE MARKET

## TECHNICAL DETAILS

CAPACITY	LENGTH (MM)	WIDTH (MM)	HEIGHT (MM)	EMPTY WEIGHT (KG)	FULL WEIGHT (KG)	MAX. HOSE LENGTH (M)	CABINET DEPTH (MM)	STEEL THICKNESS INNER TANK (MM)	STEEL THICKNESS OUTER TANK (MM)
1,000 LITRE (220 GALLON)	3,148	1,779	1,675	737	1,598	6*	470	3	3
2,000 LITRE (440 GALLON)	3,693	1,879	1,886	1,040	2,743	6*	470	3	4
2,500 LITRE (550 GALLON)	3,918	2,002	1,933	1,167	3,301	12	650	3	4

\* Extended cabinet option is available if longer hose length is required (see page 32)



### INNER TANK CONNECTIONS

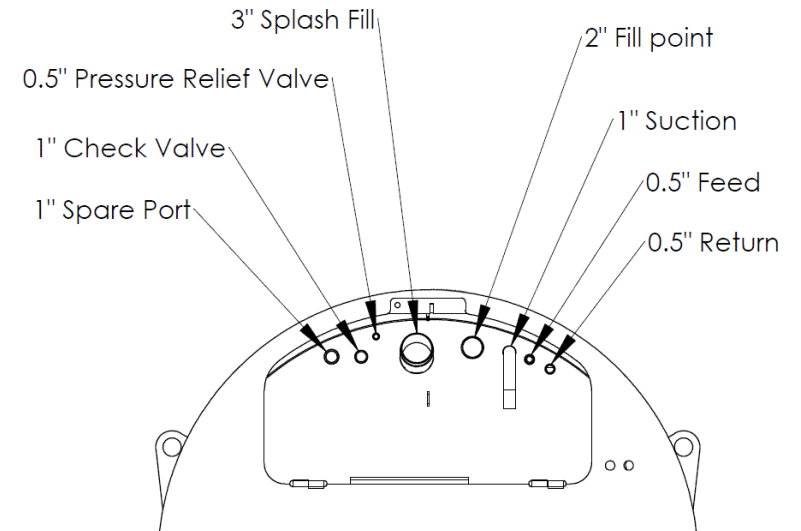









## STANDARD COLOUR:

ANTHRACITE GREY  
RAL7016

For full details on colour options, codes and lead times please turn to **page 67**

020

PACKAGE CODE	PUMP	HOSE	TRIGGER	FILTER	FLOW METER	
<b>FS010</b>						
	<p>GPI HP-100 HAND PUMP 2000-040</p>	<p>4M X 3/4" DIESEL HOSE 2400-290</p>	<p>MANUAL TRIGGER 2100-080</p>	<p>PARTICLE FILTER 2300-020</p>		
<b>FS020</b>						
	<p>GPI HP-100 HAND PUMP 2000-040</p>	<p>4M X 3/4" DIESEL HOSE 2400-290</p>	<p>MANUAL TRIGGER 2100-080</p>	<p>PARTICLE FILTER 2300-020</p>	<p>3 DIGIT FLOW METER 2200-040</p>	

# FUEL DISPENSING PACKAGES

12V PUMP OPTIONS

# FUELSTORE / HIGHWAY / DE-MOUNT / SITE

PACKAGE CODE	PUMP	HOSE	TRIGGER	FILTER	FLOW METER	BATTERY AND CARRIER
<b>FS050</b>						
	12/24V 50L/MIN PUMP 2001-500	4M X 3/4" DIESEL HOSE 2400-290	AUTO SHUT-OFF TRIGGER 2150-100	PARTICLE FILTER 2300-020		
<b>FS060</b>						
	12/24V 50L/MIN PUMP 2001-500	4M X 3/4" DIESEL HOSE 2400-290	AUTO SHUT-OFF TRIGGER 2150-100	PARTICLE FILTER 2300-020	3 DIGIT FLOW METER 2200-040	
<b>FS070</b>						
	12/24V 50L/MIN PUMP 2001-500	4M X 3/4" DIESEL HOSE 2400-290	AUTO SHUT-OFF TRIGGER 2150-100	PARTICLE FILTER 2300-020		12V BATTERY / CARRIER 2550-040
<b>FS080</b>						
	12/24V 50L/MIN PUMP 2001-500	4M X 3/4" DIESEL HOSE 2400-290	AUTO SHUT-OFF TRIGGER 2150-100	PARTICLE FILTER 2300-020	3 DIGIT FLOW METER 2200-040	12V BATTERY / CARRIER 2550-040









PACKAGE CODE	PUMP	HOSE	TRIGGER	FILTER	FLOW METER	BATTERY AND CARRIER
<b>FS 130</b>						
	12V 85 LITRE/MIN PUMP 2010-100	4M X 1" DIESEL HOSE 2400-295	HIGH FLOW AUTO TRIGGER 2150-122	HIGH FLOW PARTICLE FILTER 2300-380		
<b>FS 140</b>						
	12V 85 LITRE/MIN PUMP 2010-100	4M X 1" DIESEL HOSE 2400-295	HIGH FLOW AUTO TRIGGER 2150-122	HIGH FLOW PARTICLE FILTER 2300-380	3 DIGIT FLOW METER 2200-040	
<b>FS 160</b>						
	12V 85 LITRE/MIN PUMP 2010-100	4M X 1" DIESEL HOSE 2400-295	HIGH FLOW AUTO TRIGGER 2150-122	HIGH FLOW PARTICLE FILTER 2300-380	3 DIGIT FLOW METER 2200-040	12V BATTERY / CARRIER 2550-040



# FUEL DISPENSING PACKAGES

230V ELECTRIC PUMP OPTIONS



# FUELSTORE / HIGHWAY / DE-MOUNT / SITE

PACKAGE CODE	PUMP	HOSE	TRIGGER	FILTER	FLOW METER	BATTERY AND CARRIER
<b>FS250</b>						
	72L/MIN 230V PUMP 2020-080	4M X 1" DIESEL HOSE 2400-295	AUTO SHUT-OFF TRIGGER 2150-100	PARTICLE FILTER 2300-020		
<b>FS260</b>						
	72L/MIN 230V PUMP 2020-080	4M X 1" DIESEL HOSE 2400-295	AUTO SHUT-OFF TRIGGER 2150-100	PARTICLE FILTER 2300-020	3 DIGIT FLOW METER 2200-040	

# FUELSTORE / HIGHWAY / DE-MOUNT / SITE

# FUEL DISPENSING PACKAGES

PETROL ENGINED PUMP OPTIONS

PACKAGE CODE	PUMP	HOSE	TRIGGER	FILTER	FLOW METER
<b>FS340</b>					
	PETROL ENGINED PUMP 2030-020	4M X 1" DIESEL HOSE 2400-295	HIGH FLOW AUTO TRIGGER 2150-122	HIGH FLOW PARTICLE FILTER 2300-380	3 DIGIT FLOW METER 2200-040
<b>FS350</b>					
	PETROL ENGINED PUMP 2030-020	4M X 1" DIESEL HOSE 2400-295	HIGH FLOW AUTO TRIGGER 2150-122	HIGH FLOW PARTICLE FILTER 2300-380	

# OPTIONAL EQUIPMENT

WATER FILTER / SOLAR PANEL

# FUELSTORE / HIGHWAY / DE-MOUNT / SITE

PACKAGE CODE	FILTER	
<b>W</b> TO BE FITTED IN ADDITION TO PARTICLE FILTER		
<b>2 MICRON WATER BLOCKING FILTER + FILTER HEAD</b> 2300-375 / 2300-383		
ITEM CODE	OPTIONAL EQUIPMENT	
<b>2560-102</b>		
<b>20W 12V SOLAR PANEL C/W CHARGE CONTROLLER AND MOUNTING BRACKET</b>		

ITEM CODE

OPTIONAL EQUIPMENT

**5300-100**



SPARE WHEEL AND CARRIER - FITTED  
(HIGHWAY FUEL BOWSERS ONLY)

**4065-050 / 4065-053**



HEAVY DUTY POLYETHYLENE TOOLBOX (250L CAPACITY)  
WITH MOUNTING BRACKET - FITTED (FOR USE ON 1000L/2000L HIGHWAY BOWSERS ONLY)

ITEM	CODE
EXTENDED CABINET ON FUELSTORES	5100-100
SPLIT COMPARTMENT ON FUELSTORES	5101-100

# SITE TOW DIESEL BOWSERS - 3000 TO 9000 LITRES

THE TOUGHEST SITE TOW BOWSERS ON THE MARKET



9,000 LITRE SITE TOW DIESEL BOWSER



4,500 LITRE SITE TOW DIESEL BOWSER



HEAVY DUTY INTEGRAL STEEL CHASSIS BUILT FOR USE ON ROUGH TERRAIN



IMPROVED REAR LIGHTING



LARGE FLOTATION TYRES FOR OFF-ROAD USE GALVANISED REFUELLING PLATFORM (6000 & 9000L)

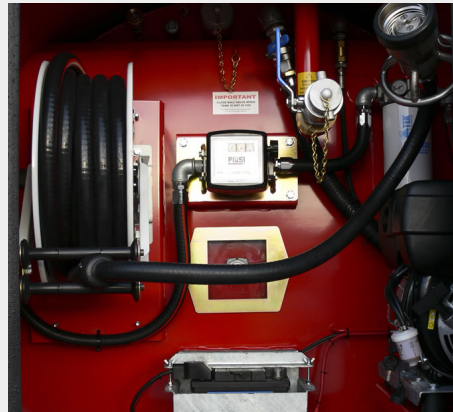

FULL HEIGHT CABINET ON ALL MODELS ALLOWS FOR EASY ACCESS TO FUEL DISPENSING EQUIPMENT

## OVERVIEW

The Fuel Proof range of bunded site tow bowzers combines safe, secure fuel storage with on-site mobility. Both the inner and outer tanks are constructed from steel throughout, with a 110% bund capacity in accordance with the PPG2 Pollution Prevention guidelines.

## KEY FEATURES

- ▶ Fully compliant with current environmental regulations
- ▶ Steel tank and heavy duty integral chassis make these units the strongest and most durable on the market
- ▶ Baffled inner tank ensuring excellent stability
- ▶ Full height cabinet for access to dispensing equipment
- ▶ Galvanised refuelling platform (6,000 and 9,000 litre models)
- ▶ Manway for tank cleaning and inspection
- ▶ Heavy duty running gear and steel mudguards
- ▶ Hydraulic brakes
- ▶ Improved LED rear lights and brighter LED work lights
- ▶ Shot blasted to SA 2.5 and painted in 2-pack polyurethane finish
- ▶ 3 year warranty for peace of mind

## PRODUCT CODES / PRICES

CAPACITY	ACCESS PLATFORM	CODE
3,000 LITRE (660 GALLON)	×	0440
4,500 LITRE (1,000 GALLON)	×	0450
6,000 LITRE (1,310 GALLON)	✓	0460
9,000 LITRE (1,978 GALLON)	✓	0470

Please note bowser prices do not include fuel dispensing equipment

FOR FUEL DISPENSING OPTIONS PLEASE TURN TO PAGE 35

# SITE TOW DIESEL BOWSERS - 3000 TO 9000 LITRES

THE TOUGHEST SITE TOW BOWSERS ON THE MARKET

## TECHNICAL DETAILS

CAPACITY	LENGTH (MM)	WIDTH (MM)	HEIGHT (MM)	EMPTY WEIGHT (KG)	FULL WEIGHT (KG)	MAX. HOSE LENGTH (M)	CABINET DEPTH (MM)	STEEL THICKNESS INNER TANK (MM)	STEEL THICKNESS OUTER TANK (MM)
3,000 LITRES (660 GALLONS)	4,639	2,202	2,313	1,759	4,287	12	886	3	4
4,500 LITRES (1,000 GALLONS)	5,589	2,383	2,535	2,754	6,665	12	793	5	4
6,000 LITRES (1,310 GALLONS)	5,935	2,700	2,712	3,380	8,516	30	991	5	5
9,000 LITRES (1,978 GALLONS)	6,733	2,738	2,713	4,167	11,902	30	1,001	5	5



## TANK CONNECTIONS

- ▶ Rotary tank contents gauge
- ▶ 3" BSP fill point
- ▶ 2" BSP fill point
- ▶ 2" suction line with overflow

## STANDARD COLOUR:

ANTHRACITE  
GREY  
RAL7016

020

For full details on colour options, codes and lead times please turn to **page 67**

# SITE TOW DIESEL BOWSERS - 3000 TO 9000 LITRES

THE TOUGHEST SITE TOW BOWSERS ON THE MARKET

# FUEL DISPENSING PACKAGES

PETROL ENGINED PUMP OPTIONS

PACKAGE CODE	PUMP	HOSE / REEL	TRIGGER	FILTER	FLOW METER
<b>ST010</b>					
	120 L/MIN PETROL ENGINED PUMP 2030-020	6M X 1" DIESEL HOSE 2400-299	HIGH FLOW AUTO TRIGGER 2150-122	HIGH FLOW PARTICLE FILTER 2300-380	3 DIGIT FLOW METER 2200-040
<b>ST020</b>					
	100 L/MIN PETROL ENGINED PUMP 2030-020	REEL WITH 12M X 1" HOSE 2500-096	HIGH FLOW AUTO TRIGGER 2150-122	HIGH FLOW PARTICLE FILTER 2300-380	3 DIGIT FLOW METER 2200-040
<b>ST030</b>					
	150 L/MIN PETROL ENGINED PUMP 2030-020	REEL WITH 10M X 1 1/2" HOSE 2500-140 / 2400-200	HIGH FLOW 1 1/2" AUTO TRIGGER 2150-162	HIGH FLOW PARTICLE FILTER 2300-380	3 DIGIT FLOW METER 2200-260





# FUEL DISPENSING PACKAGES

HYDRAULIC POWERED PUMP OPTIONS

# SITE TOW DIESEL BOWSERS - 3000 TO 9000 LITRES

THE TOUGHEST SITE TOW BOWSERS ON THE MARKET

PACKAGE CODE	PUMP	HOSE	TRIGGER	FILTER	FLOW METER
<b>ST040</b>					
	120 L/MIN HYDRAULIC PUMP / SPOOL VALVE 2050-020 / 2051-010	6M X 1" DIESEL HOSE 2400-299	HIGH FLOW AUTO TRIGGER 2150-122	HIGH FLOW PARTICLE FILTER 2300-380	3 DIGIT FLOW METER 2200-040
<b>ST050</b>					
	110 L/MIN HYDRAULIC PUMP / SPOOL VALVE 2050-020 / 2051-010	REEL WITH 12M X 1" HOSE 2500-096	HIGH FLOW AUTO TRIGGER 2150-122	HIGH FLOW PARTICLE FILTER 2300-380	3 DIGIT FLOW METER 2200-040
<b>ST060</b>					
	150 L/MIN HYDRAULIC PUMP / SPOOL VALVE 2050-020 / 2051-010	REEL WITH 10M X 1 1/2" HOSE 2500-140 / 2400-200	HIGH FLOW 1/2" AUTO TRIGGER 2150-162	HIGH FLOW PARTICLE FILTER 2300-380	3 DIGIT FLOW METER 2200-260

# SITE TOW DIESEL BOWSERS - 3000 TO 9000 LITRES

THE TOUGHEST SITE TOW BOWSERS ON THE MARKET

# FUEL DISPENSING PACKAGES

DIESEL ENGINED PUMP OPTIONS

PACKAGE CODE	PUMP	HOSE / REEL	TRIGGER	FILTER	FLOW METER	BATTERY AND CARRIER
<b>ST070</b>						
	120 L/MIN DIESEL ENGINED PUMP 2033-100	6M X 1" DIESEL HOSE 2400-299	HIGH FLOW AUTO TRIGGER 2150-122	HIGH FLOW PARTICLE FILTER 2300-380	3 DIGIT FLOW METER 2200-040	12V BATTERY / CARRIER 2550-040
<b>ST080</b>						
	110 L/MIN DIESEL ENGINED PUMP 2033-100	REEL WITH 12M X 1" HOSE 2500-096	HIGH FLOW AUTO TRIGGER 2150-122	HIGH FLOW PARTICLE FILTER 2300-380	3 DIGIT FLOW METER 2200-040	12V BATTERY / CARRIER 2550-040
<b>ST090</b>						
	150 L/MIN DIESEL ENGINED PUMP 2033-100	REEL WITH 10M X 1 1/2" HOSE 2500-140 / 2400-200	HIGH FLOW 1 1/2" AUTO TRIGGER 2150-162	HIGH FLOW PARTICLE FILTER 2300-380	3 DIGIT FLOW METER 2200-260	12V BATTERY / CARRIER 2550-040

# OPTIONAL EQUIPMENT

## WATER FILTER OPTION

# SITE TOW DIESEL BOWSERS - 3000 TO 9000 LITRES

## THE TOUGHEST SITE TOW BOWSERS ON THE MARKET

PACKAGE CODE	FILTER	
<b>W</b> TO BE FITTED IN ADDITION TO PARTICLE FILTER		
	2 MICRON WATER BLOCKING FILTER + FILTER HEAD 2300-375 / 2300-383	

# BULK DIESEL TANKS - HORIZONTAL

## THE ULTIMATE FUEL STORAGE SOLUTION



42,000 LITRE HORIZONTAL BULK DIESEL TANK



ROLLER SHUTTER DOOR OPTION ALSO AVAILABLE



FULL HEIGHT LOCKABLE CABINET FOR EASY ACCESS TO DISPENSING EQUIPMENT AND TANK CONNECTIONS



HIGH SECURITY STEEL DOOR FEATURES CONCEALED HINGES AND HEAVY DUTY SLIDING LOCK BOLT TO KEEP FUEL SAFE AND SECURE



AVAILABLE WITH A WIDE RANGE OF DISPENSING EQUIPMENT INCLUDING FUEL MANAGEMENT AND COMBINED ALARM SYSTEMS - AS SHOWN ABOVE

## KEY FEATURES

- ▶ All-steel construction for unbeatable security and durability
- ▶ 110% bunded & fully compliant with current environmental regulations
- ▶ Full height cabinet for easy access to fuel dispensing equipment
- ▶ Self supporting design for low cost and fast installation
- ▶ Unique external overflow prevention system for safe tank filling
- ▶ Electrical connection panel for easy connection to mains power supply
- ▶ Shot blasted and painted in 2-pack polyurethane paint
- ▶ 15 year warranty for peace of mind

## PRODUCT CODES / PRICES

CAPACITY	CODE	
	ROLLER SHUTTER DOOR / STEEL DOOR OPTION	
5,000 LITRE (1,098 GALLON)	0220 / 0221	
7,500 LITRE (1,648 GALLON)	0225 / 0226	
10,000 LITRE (2,200 GALLON)	0227 / 0228	
15,000 LITRE (3,300 GALLON)	0232 / 0233	
22,500 LITRE (5,000 GALLON)	0240 / 0240	
27,500 LITRE (6,000 GALLON)	0244 / 0245	
32,000 LITRE (7,000 GALLON)	0247 / 0248	
42,000 LITRE (9,230 GALLON)	0273 / 0276	
50,000 LITRE (10,990 GALLON)	0274 / 0277	
60,000 LITRE (13,185 GALLON)	0278 / 0279	

Please note tank prices do not include fuel dispensing equipment

## STANDARD COLOURS:

ANTHRACITE GREY

RAL7016

020

DEEP BRONZE GREEN

BS381C/224

060

For full details on colour options, codes and lead times please turn to **page 67**

**FOR FUEL DISPENSING OPTIONS PLEASE TURN TO PAGE 41**

# BULK DIESEL TANKS - HORIZONTAL

## THE ULTIMATE FUEL STORAGE SOLUTION

## TECHNICAL DETAILS

TANK CAPACITY	LENGTH (MM)	WIDTH (MM)	HEIGHT (MM)	EMPTY WEIGHT (KG)	FULL WEIGHT (KG)	MAX. HOSE LENGTH (M)	CABINET DEPTH (MM)	STEEL THICKNESS INNER TANK (MM)	STEEL THICKNESS OUTER TANK (MM)
5,000 LITRES (1,098 GALLONS)	3,147	2,079	2,169	1,834	6,087	30	981	4	4
7,500 LITRES (1,648 GALLONS)	4,137	2,079	2,169	2,187	8,646	30	964	4	4
10,000 LITRES (2,200 GALLONS)	4,137	2,339	2,416	2,638	11,175	30	964	4	4
15,000 LITRES (3,300 GALLONS)	5,647	2,220	2,430	3,361	16,116	30	964	4	4
22,500 LITRES (5,000 GALLONS)	6,655	2,534	2,874	5,450	24,933	30	900	5	5
27,500 LITRES (6,000 GALLONS)	7,653	2,534	2,865	6,062	29,057	30	978	5	5
32,000 LITRES (7,000 GALLONS)	8,666	2,534	2,877	6,752	34,540	30	968	5	5
42,000 LITRES (9,230 GALLONS)	9,290	2,804	3,216	9,315	45,146	30	970	6	6
50,000 LITRES (10,990 GALLONS)	10,810	2,804	3,226	10,514	52,194	30	974	6	6
60,000 LITRES (13,185 GALLONS)	12,969	2,804	3,225	12,190	63,440	30	1,124	6	6



22,500 LITRE HORIZONTAL BULK DIESEL TANK



HEAVY DUTY STEEL CONSTRUCTION PROVIDES OUTSTANDING DURABILITY AND RELIABILITY EVEN IN THE HARSHTEST CONDITIONS

## TANK CONNECTIONS

- ▶ 2" BSP offset fill point
- ▶ External overflow prevention system
- ▶ 1½" suction line dip tube for fuel delivery
- ▶ 1" port for tank level sensor
- ▶ 1" bund drain point
- ▶ ½" port for high level sensor

# BULK DIESEL TANKS - HORIZONTAL

THE ULTIMATE FUEL STORAGE SOLUTION

# FUEL DISPENSING PACKAGES

230V FUEL DISPENSING SYSTEM OPTIONS



PACKAGE CODE	DISPENSING SYSTEM	HOSE / REEL	TRIGGER	FILTER	ELECTRICAL CONNECTION
<b>BH 090</b>					
	CUBE 70L/MIN 230V 2070-080	4M X 1" DIESEL HOSE 2400-295	AUTO SHUT-OFF TRIGGER 2150-100	HIGH FLOW PARTICLE FILTER 2300-380	MAINS PANEL WITH OCIO GAUGE 2570-040
<b>BH 100</b>					
	CUBE 70L/MIN 230V 2070-080	REEL WITH 8M X 1" HOSE 2500-092	AUTO SHUT-OFF TRIGGER 2150-100	HIGH FLOW PARTICLE FILTER 2300-380	MAINS PANEL WITH OCIO GAUGE 2570-040
<b>BH 130</b>					
	CUBE 70L/MIN 230V 2070-080	4M X 1" DIESEL HOSE 2400-295	AUTO SHUT-OFF TRIGGER 2150-100	HIGH FLOW PARTICLE FILTER 2300-380	MAINS PANEL + OCIO + ALARM 2591-025
<b>BH 140</b>					
	CUBE 70L/MIN 230V 2070-080	REEL WITH 8M X 1" HOSE 2500-092	AUTO SHUT-OFF TRIGGER 2150-100	HIGH FLOW PARTICLE FILTER 2300-380	MAINS PANEL + OCIO + ALARM 2591-025

# FUEL DISPENSING PACKAGES

230V FUEL DISPENSING SYSTEM OPTIONS

# BULK DIESEL TANKS - HORIZONTAL

THE ULTIMATE FUEL STORAGE SOLUTION

PACKAGE CODE	DISPENSING SYSTEM	HOSE / REEL	TRIGGER	FILTER	ELECTRICAL CONNECTION
<b>BH 170</b>					
	ALPHA 70L/MIN 230V 2070-310	4M X 1" DIESEL HOSE 2400-295	AUTO SHUT-OFF TRIGGER 2150-100	HIGH FLOW PARTICLE FILTER 2300-380	MAINS PANEL WITH OCIO GAUGE 2570-040
<b>BH 180</b>					
	ALPHA 70L/MIN 230V 2070-310	REEL WITH 8M X 1" HOSE 2500-092	AUTO SHUT-OFF TRIGGER 2150-100	HIGH FLOW PARTICLE FILTER 2300-380	MAINS PANEL WITH OCIO GAUGE 2570-040
<b>BH210</b>					
	ALPHA 70L/MIN 230V 2070-310	4M X 1" DIESEL HOSE 2400-295	AUTO SHUT-OFF TRIGGER 2150-100	HIGH FLOW PARTICLE FILTER 2300-380	MAINS PANEL + OCIO + ALARM 2591-025
<b>BH220</b>					
	ALPHA 70L/MIN 230V 2070-310	REEL WITH 8M X 1" HOSE 2500-092	AUTO SHUT-OFF TRIGGER 2150-100	HIGH FLOW PARTICLE FILTER 2300-380	MAINS PANEL + OCIO + ALARM 2591-025

# BULK DIESEL TANKS - HORIZONTAL

THE ULTIMATE FUEL STORAGE SOLUTION

# FUEL DISPENSING PACKAGES

230V FUEL DISPENSING SYSTEM OPTIONS

PACKAGE CODE	DISPENSING SYSTEM	HOSE / REEL	TRIGGER	FILTER	ELECTRICAL CONNECTION
<b>BH250</b>					
	ALPHA 90L/MIN 230V 2070-320	4M X 1" DIESEL HOSE 2400-295	HIGH FLOW AUTO TRIGGER 2150-122	HIGH FLOW PARTICLE FILTER 2300-380	MAINS PANEL WITH OCIO GAUGE 2570-040
<b>BH260</b>					
	ALPHA 90L/MIN 230V 2070-320	REEL WITH 8M X 1" HOSE 2500-092	HIGH FLOW AUTO TRIGGER 2150-122	HIGH FLOW PARTICLE FILTER 2300-380	MAINS PANEL WITH OCIO GAUGE 2570-040
<b>BH290</b>					
	ALPHA 90L/MIN 230V 2070-320	4M X 1" DIESEL HOSE 2400-295	AUTO SHUT-OFF TRIGGER 2150-100	HIGH FLOW PARTICLE FILTER 2300-380	MAINS PANEL + OCIO + ALARM 2591-025
<b>BH300</b>					
	ALPHA 90L/MIN 230V 2070-320	REEL WITH 8M X 1" HOSE 2500-092	AUTO SHUT-OFF TRIGGER 2150-100	HIGH FLOW PARTICLE FILTER 2300-380	MAINS PANEL + OCIO + ALARM 2591-025























# FUEL DISPENSING PACKAGES

230V FUEL MANAGEMENT SYSTEM OPTIONS

# BULK DIESEL TANKS - HORIZONTAL

THE ULTIMATE FUEL STORAGE SOLUTION

PACKAGE CODE	MANAGEMENT SYSTEM	HOSE / REEL	TRIGGER	FILTER	ELECTRICAL CONNECTION
<b>BH330*</b>					
	CUBE 70MC 230V C/W 10 USER KEYS, MANAGER KEY, SOFTWARE (DOWNLOAD*) & KEY READER - 2070-100	4M X 1" DIESEL HOSE 2400-295	AUTO SHUT-OFF TRIGGER 2150-100	HIGH FLOW PARTICLE FILTER 2300-380	MAINS PANEL WITH OCIO GAUGE 2570-040
<b>BH340*</b>					
	CUBE 70MC 230V C/W 10 USER KEYS, MANAGER KEY, SOFTWARE (DOWNLOAD*) & KEY READER - 2070-100	REEL WITH 8M X 1" HOSE 2500-092	AUTO SHUT-OFF TRIGGER 2150-100	HIGH FLOW PARTICLE FILTER 2300-380	MAINS PANEL WITH OCIO GAUGE 2570-040
<b>BH370*</b>					
	CUBE 70MC 230V C/W 10 USER KEYS, MANAGER KEY, SOFTWARE (DOWNLOAD*) & KEY READER - 2070-100	4M X 1" DIESEL HOSE 2400-295	AUTO SHUT-OFF TRIGGER 2150-100	HIGH FLOW PARTICLE FILTER 2300-380	MAINS PANEL + OCIO + ALARM 2591-021
<b>BH380*</b>					
	CUBE 70MC 230V C/W 10 USER KEYS, MANAGER KEY, SOFTWARE (DOWNLOAD*) & KEY READER - 2070-100	REEL WITH 8M X 1" HOSE 2500-092	AUTO SHUT-OFF TRIGGER 2150-100	HIGH FLOW PARTICLE FILTER 2300-380	MAINS PANEL + OCIO + ALARM 2591-021

\*Cube 70MC software also available on USB drive (£POA)

# BULK DIESEL TANKS - HORIZONTAL

THE ULTIMATE FUEL STORAGE SOLUTION

# FUEL DISPENSING PACKAGES

230V FUEL MANAGEMENT SYSTEM OPTIONS

PACKAGE CODE	MANAGEMENT SYSTEM	HOSE / REEL	TRIGGER	FILTER	ELECTRICAL CONNECTION
<b>BH410</b>					
	ALPHA 70L/MIN 230V 2070-400	4M X 1" DIESEL HOSE 2400-295	AUTO SHUT-OFF TRIGGER 2150-100	HIGH FLOW PARTICLE FILTER 2300-380	MAINS PANEL WITH OCIO GAUGE 2570-040
<b>BH420</b>					
	ALPHA 70L/MIN 230V 2070-400	REEL WITH 8M X 1" HOSE 2500-092	AUTO SHUT-OFF TRIGGER 2150-100	HIGH FLOW PARTICLE FILTER 2300-380	MAINS PANEL WITH OCIO GAUGE 2570-040
<b>BH450</b>					
	ALPHA 70L/MIN 230V 2070-400	4M X 1" DIESEL HOSE 2400-295	AUTO SHUT-OFF TRIGGER 2150-100	HIGH FLOW PARTICLE FILTER 2300-380	MAINS PANEL + OCIO + ALARM 2591-025
<b>BH460</b>					
	ALPHA 70L/MIN 230V 2070-400	REEL WITH 8M X 1" HOSE 2500-092	AUTO SHUT-OFF TRIGGER 2150-100	HIGH FLOW PARTICLE FILTER 2300-380	MAINS PANEL + OCIO + ALARM 2591-025

# FUEL DISPENSING PACKAGES

230V FUEL MANAGEMENT SYSTEM OPTIONS

# BULK DIESEL TANKS - HORIZONTAL

THE ULTIMATE FUEL STORAGE SOLUTION

PACKAGE CODE	MANAGEMENT SYSTEM	HOSE / REEL	TRIGGER	FILTER	ELECTRICAL CONNECTION
<b>BH490</b>					
	ALPHA 90L/MIN 230V 2070-420	4M X 1" DIESEL HOSE 2400-295	HIGH FLOW AUTO TRIGGER 2150-122	HIGH FLOW PARTICLE FILTER 2300-380	MAINS PANEL WITH OCIO GAUGE 2570-040
<b>BH500</b>					
	ALPHA 90L/MIN 230V 2070-420	REEL WITH 8M X 1" HOSE 2500-092	HIGH FLOW AUTO TRIGGER 2150-122	HIGH FLOW PARTICLE FILTER 2300-380	MAINS PANEL WITH OCIO GAUGE 2570-040
<b>BH530</b>					
	ALPHA 90L/MIN 230V 2070-420	4M X 1" DIESEL HOSE 2400-295	AUTO SHUT-OFF TRIGGER 2150-100	HIGH FLOW PARTICLE FILTER 2300-380	MAINS PANEL + OCIO + ALARM 2591-025
<b>BH540</b>					
	ALPHA 90L/MIN 230V 2070-420	REEL WITH 8M X 1" HOSE 2500-092	AUTO SHUT-OFF TRIGGER 2150-100	HIGH FLOW PARTICLE FILTER 2300-380	MAINS PANEL + OCIO + ALARM 2591-025

# BULK DIESEL TANKS - HORIZONTAL

THE ULTIMATE FUEL STORAGE SOLUTION

# OPTIONAL EQUIPMENT

WATER FILTER OPTION

PACKAGE CODE	FILTER	
<b>W</b> TO BE FITTED IN ADDITION TO PARTICLE FILTER		
	<b>2 MICRON WATER BLOCKING FILTER + FILTER HEAD</b> 2300-375 / 2300-383	









<b>ITEM</b>	<b>CODE</b>
<b>SPLIT COMPARTMENT ON 5000L TO 15000L HORIZONTAL BULK TANKS</b>	<b>5101-120</b>
<b>SPLIT COMPARTMENT ON 22500L TO 32000L HORIZONTAL BULK TANKS</b>	<b>5101-140</b>
<b>SPLIT COMPARTMENT ON 42000L TO 60000L HORIZONTAL BULK TANKS</b>	<b>5101-200</b>

# OPTIONAL EQUIPMENT / ACCESSORIES

FUEL PROOF TANK PACK / FUEL MANAGEMENT SYSTEM ACCESSORIES

# BULK DIESEL TANKS - HORIZONTAL

THE ULTIMATE FUEL STORAGE SOLUTION

ITEM CODE	OPTIONAL EQUIPMENT		
2981-020			
<p>FUEL PROOF 'TANK PACK' FOR BULK DIESEL TANKS: 45 LITRE SPILL KIT, 6KG FIRE EXTINGUISHER &amp; 'GLOVE PARK'</p>			
2071-200			
<p>SOFTWARE &amp; KEY KIT FOR PIUSI CUBE 70MC SYSTEM: PC SOFTWARE (DOWNLOAD), 1 MANAGER KEY, 10 USER KEYS, PC KEY READER</p>			
2071-210			
<p>SOFTWARE &amp; KEY KIT FOR PIUSI CUBE 70MC SYSTEM: PC SOFTWARE (USB), 1 MANAGER KEY, 10 USER KEYS, PC KEY READER</p>			
2071-080			
<p>PACK OF 10 USER KEYS FOR PIUSI CUBE 70MC SYSTEM</p>			

# BULK DIESEL TANKS - VERTICAL

BIG STORAGE CAPACITY WITH A SMALL FOOTPRINT



12,500 LITRE VERTICAL BULK DIESEL TANK



**NEW** CABINET DESIGN FOR IMPROVED ACCESS TO FUEL DISPENSING EQUIPMENT AND TANK CONNECTIONS

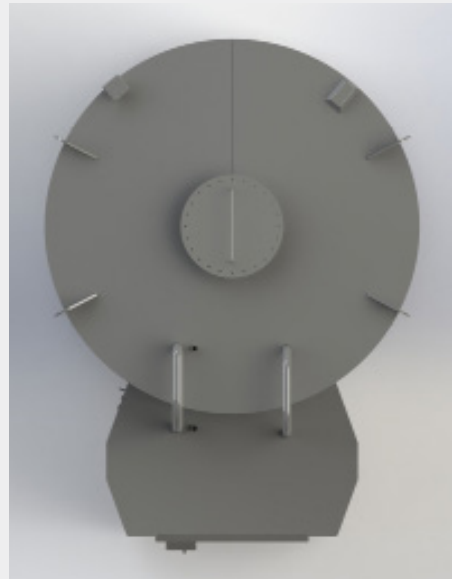

**NEW** IMPROVED PAINT FINISH FOR BETTER DURABILITY AND TANK PROTECTION

## OVERVIEW

Vertical, cylindrical bulk diesel tanks in capacities from 5,200 litres (1,140 gallons) to 18,000 litres (3,950 gallons). Heavy duty double cylinder design with an all-steel construction. Large fuel cabinet provides access to tank connections and dispensing equipment. Fully bunded and pressure tested inner tanks; built in accordance with current environmental regulations. The vertical design makes these tanks ideal when space is limited, and the self-supporting design ensures a quick and hassle-free installation.

## KEY FEATURES

- ▶ All-steel construction for unbeatable strength and durability
- ▶ 110% bunded and fully compliant with current environmental regulations
- ▶ Lockable steel door keeps tank connections safe and secure
- ▶ Vertical design provides high capacity with a small footprint, ideal when space is limited
- ▶ Large fuel dispensing cabinet for access to fuel dispensing equipment
- ▶ Available with a range of dispensing systems to suit your requirements
- ▶ 15 year warranty for peace of mind

## PRODUCT CODES / PRICES

CAPACITY	CODE
5,200 LITRE (1,140 GALLON)	0212
10,000 LITRE (2,200 GALLON)	0213
12,500 LITRE (2,750 GALLON)	0214
18,000 LITRE (3,950 GALLON)	0216

Please note tank prices do not include fuel dispensing equipment

FOR FUEL DISPENSING OPTIONS PLEASE TURN TO PAGE 53



# BULK DIESEL TANKS - VERTICAL

## BIG STORAGE CAPACITY WITH A SMALL FOOTPRINT

## TECHNICAL DETAILS

CAPACITY	LENGTH (MM)	WIDTH (MM)	HEIGHT (MM)	EMPTY WEIGHT (KG)	FULL WEIGHT (KG)	MAX. HOSE LENGTH (M)	CABINET DEPTH (MM)	STEEL THICKNESS INNER TANK (MM)	STEEL THICKNESS OUTER TANK (MM)
5,200 LITRE (1,140 GALLON)	2,804	1,985	2,341	1,341	5,765	10	713	3	3
10,000 LITRE (2,200 GALLON)	2,950	2,200	3,369	2,129	10,651	10	684	4	4
12,500 LITRE (2,750 GALLON)	3,234	2,468	3,376	3,000	13,755	10	684	5	5
18,000 LITRE (3,950 GALLON)	3,769	2,956	3,434	4,127	19,434	10	700	6	6



**NEW DESIGN** 5,200 LITRE VERTICAL BULK DIESEL TANK WITH FULL HEIGHT FUEL DISPENSING CABINET

## STANDARD COLOURS:

ANTHRACITE GREY	DEEP BRONZE GREEN
RAL7016	BS381C/224
020	060

For full details on colour options, codes and lead times please turn to **page 67**

## TANK CONNECTIONS

- ▶ Rotary tank contents gauge
- ▶ 2" BSP fill point with overflow prevention valve
- ▶ 1½" suction line dip tube

# BULK DIESEL TANKS - VERTICAL

BIG STORAGE CAPACITY WITH A SMALL FOOTPRINT

# FUEL DISPENSING PACKAGES

230V FUEL DISPENSING SYSTEM OPTIONS





















PACKAGE CODE	DISPENSING SYSTEM	HOSE / REEL	TRIGGER	FILTER	ELECTRICAL CONNECTION
<b>BV210</b>					
	CUBE 70L/MIN 230V 2070-080	4M X 1" DIESEL HOSE 2400-295	AUTO SHUT-OFF TRIGGER 2150-100	HIGH FLOW PARTICLE FILTER 2300-380	MAINS PANEL WITH OCIO GAUGE 2570-040
<b>BV220</b>					
	CUBE 70L/MIN 230V 2070-080	REEL WITH 8M X 1" HOSE 2500-010 / 2400-180	AUTO SHUT-OFF TRIGGER 2150-100	HIGH FLOW PARTICLE FILTER 2300-380	MAINS PANEL WITH OCIO GAUGE 2570-040
<b>BV250</b>					
	CUBE 70L/MIN 230V 2070-080	4M X 1" DIESEL HOSE 2400-295	AUTO SHUT-OFF TRIGGER 2150-100	HIGH FLOW PARTICLE FILTER 2300-380	MAINS PANEL + OCIO + ALARM 2591-021
<b>BV260</b>					
	CUBE 70L/MIN 230V 2070-080	REEL WITH 8M X 1" HOSE 2500-010 / 2400-180	AUTO SHUT-OFF TRIGGER 2150-100	HIGH FLOW PARTICLE FILTER 2300-380	MAINS PANEL + OCIO + ALARM 2591-021

# FUEL DISPENSING PACKAGES

230V FUEL MANAGEMENT SYSTEM OPTIONS

## BULK DIESEL TANKS - VERTICAL

BIG STORAGE CAPACITY WITH A SMALL FOOTPRINT

PACKAGE CODE	MANAGEMENT SYSTEM	HOSE / REEL	TRIGGER	FILTER	ELECTRICAL CONNECTION
<b>BV290*</b>					
	CUBE 70MC 230V C/W 10 USER KEYS, MANAGER KEY, SOFTWARE (DOWNLOAD*) & KEY READER - 2070-100	4M X 1" DIESEL HOSE 2400-295	AUTO SHUT-OFF TRIGGER 2150-100	HIGH FLOW PARTICLE FILTER 2300-380	MAINS PANEL WITH OCIO GAUGE 2570-040
<b>BV300*</b>					
	CUBE 70MC 230V C/W 10 USER KEYS, MANAGER KEY, SOFTWARE (DOWNLOAD*) & KEY READER - 2070-100	REEL WITH 8M X 1" HOSE 2500-010 / 2400-180	AUTO SHUT-OFF TRIGGER 2150-100	HIGH FLOW PARTICLE FILTER 2300-380	MAINS PANEL WITH OCIO GAUGE 2570-040
<b>BV330*</b>					
	CUBE 70MC 230V C/W 10 USER KEYS, MANAGER KEY, SOFTWARE (DOWNLOAD*) & KEY READER - 2070-100	4M X 1" DIESEL HOSE 2400-295	AUTO SHUT-OFF TRIGGER 2150-100	HIGH FLOW PARTICLE FILTER 2300-380	MAINS PANEL + OCIO + ALARM 2591-021
<b>BV340*</b>					
	CUBE 70MC 230V C/W 10 USER KEYS, MANAGER KEY, SOFTWARE (DOWNLOAD*) & KEY READER - 2070-100	REEL WITH 8M X 1" HOSE 2500-010 / 2400-180	AUTO SHUT-OFF TRIGGER 2150-100	HIGH FLOW PARTICLE FILTER 2300-380	MAINS PANEL + OCIO + ALARM 2591-021

\*Cube 70MC software also available on USB drive (£POA)

# BULK DIESEL TANKS - VERTICAL

BIG STORAGE CAPACITY WITH A SMALL FOOTPRINT

## OPTIONAL EQUIPMENT

WATER FILTER OPTION

PACKAGE CODE

FILTER

**W**

TO BE FITTED IN ADDITION TO  
PARTICLE FILTER









2 MICRON WATER BLOCKING FILTER + FILTER HEAD  
2300-375 / 2300-383

# OPTIONAL EQUIPMENT / ACCESSORIES

FUEL PROOF TANK PACK / FUEL MANAGEMENT SYSTEM ACCESSORIES

# BULK DIESEL TANKS - VERTICAL

BIG STORAGE CAPACITY WITH A SMALL FOOTPRINT

ITEM CODE	OPTIONAL EQUIPMENT		
2981-020			
<p>FUEL PROOF 'TANK PACK' FOR BULK DIESEL TANKS: 45 LITRE SPILL KIT, 6KG FIRE EXTINGUISHER &amp; 'GLOVE PARK'</p>			
2071-200			
<p>SOFTWARE &amp; KEY KIT FOR PIUSI CUBE 70MC SYSTEM: PC SOFTWARE (DOWNLOAD), 1 MANAGER KEY, 10 USER KEYS, PC KEY READER</p>			
2071-210			
<p>SOFTWARE &amp; KEY KIT FOR PIUSI CUBE 70MC SYSTEM: PC SOFTWARE (USB), 1 MANAGER KEY, 10 USER KEYS, PC KEY READER</p>			
2071-080			
<p>PACK OF 10 USER KEYS FOR PIUSI CUBE 70MC SYSTEM</p>			

# HORIZONTAL BULK DIESEL TANKS WITH ADBLUE STORAGE

ALL-IN-ONE SYSTEM FOR STORING AND DISPENSING BOTH DIESEL AND ADBLUE



DISPENSING EQUIPMENT, ADBLUE FILL POINT AND DISTRIBUTION BOARD



DIESEL/ADBLUE DISPENSING SYSTEMS



FULL HEIGHT CABINET HOUSING DUAL DISPENSING SYSTEMS



EXAMPLE OF A RECENT TANK SHIPPED TO NORWAY

## ADBLUE INFO

AdBlue, or DEF (Diesel Exhaust Fluid) as it is otherwise known, is a liquid substance composed of urea and de-ionized water. European Emission Standards have made it a legal requirement for the majority of lorries, buses, agricultural/plant machinery and now some passenger cars to use this fluid to reduce vehicle's diesel exhaust emissions to a certain level.

## OVERVIEW

Our range of dual-compartment highway bowzers are an all-in-one unit built to store, transport and dispense both Diesel and AdBlue. These units feature an all-steel construction with 110% banded Diesel tank, stainless steel AdBlue tank, twin dispensing systems and a tough galvanised chassis with heavy-duty running gear. With full UN approval, these bowzers are fully compliant with current regulations, and thanks to Fuel Proof's industry leading build quality and innovation, provide unrivalled security, durability and efficiency.

## KEY FEATURES

- ▶ Fully compliant with environmental regulations
- ▶ All-steel construction
- ▶ Dual storage: 110% banded Diesel tank & stainless-steel AdBlue tank
- ▶ Dual dispensing systems - one for each tank
- ▶ Choice of pump options to match your requirements
- ▶ Secure full height fuel dispensing cabinet
- ▶ Manway for tank cleaning and inspection
- ▶ Shot blasted to SA 2.5 and painted in 2-pack polyurethane finish

ABOVE PICTURES FOR ILLUSTRATIVE PURPOSES ONLY

# HORIZONTAL BULK DIESEL TANKS WITH ADBLUE STORAGE

ALL-IN-ONE SYSTEM FOR STORING AND DISPENSING BOTH DIESEL AND ADBLUE

## ADBLUE COMPARTMENT OPTIONS:

ADBLUE TANK CAPACITY	900L	1,200L	2,000L	3,200L	4,000L
BASE DIESEL TANK	5,000L	10,000L	10,000L	22,500L	42,000L
	7,500L	15,000L	15,000L	32,000L	50,000L
					60,000L

- ▶ AdBlue compartments include the standard AdBlue dispensing package listed below

## STANDARD ADBLUE DISPENSING PACKAGE:

PACKAGE CODE	PUMP	HOSE	TRIGGER	LEVEL GAUGE
<b>AB100</b> PRICE: INCLUDED				
	230V 35 LITRE/MIN PUMP 2080-100	4M X ADBLUE HOSE 2080-020	AUTOMATIC ADBLUE NOZZLE 2080-015	UNITOP LEVEL GAUGE 2580-030

# HIGHWAY DIESEL BOWSERS WITH ADBLUE STORAGE

FOR STORING, TRANSPORTING AND DISPENSING BOTH DIESEL AND ADBLUE



1000 LITRE HIGHWAY DIESEL BOWSER C/W 200L ADBLUE TANK



HEAVY DUTY GALVANISED STEEL CHASSIS

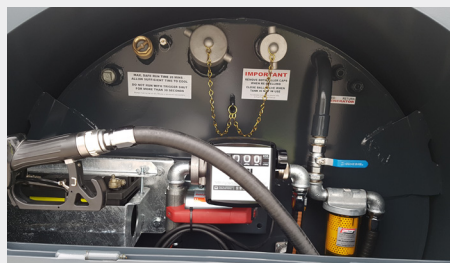

TWIN LOCKABLE DISPENSING CABINETS



STANDARD ADBLUE DISPENSING KIT: 12V PUMP, 4M HOSE, AUTO NOZZLE, UNITOP LEVEL GAUGE



ADBLUE DISPENSING EQUIPMENT / ADBLUE FILL POINT

## OVERVIEW

Our range of dual-compartment highway bowzers are an all-in-one unit built to store, transport and dispense both Diesel and AdBlue. These units feature an all-steel construction with 110% bunded Diesel tank, stainless steel AdBlue tank, twin dispensing systems and a tough galvanised chassis with heavy-duty running gear. With full UN approval, these bowzers are fully compliant with current regulations, and thanks to Fuel Proof's industry leading build quality and innovation, provide unrivalled security, durability and efficiency.

## KEY FEATURES

- ▶ UN approved for transporting diesel on the highway
- ▶ Fully compliant with current environmental regulations
- ▶ All-steel construction and heavy-duty galvanised tubular steel chassis makes these units the strongest and most durable on the market
- ▶ Dual storage: 110% bunded Diesel tank & stainless-steel AdBlue tank
- ▶ Dual dispensing systems - one for each tank
- ▶ Choice of pump options to match your machines, vehicles & application
- ▶ Galvanised mudguards for strength and durability
- ▶ Secure lockable doors with anti-vandal padlock covers
- ▶ High quality running gear for years of trouble free service
- ▶ 10 year warranty for peace of mind

## PRODUCT CODES / PRICES

CAPACITY	AXLES	UN APPROVED	CODE
1,000L DIESEL / 200L ADBLUE	TWIN	✓	0325
1,800L DIESEL / 200L ADBLUE	TWIN	✓	0335

Note: Above prices do not include Diesel dispensing equipment. Standard AdBlue dispensing kit (p.61) is included

FOR DIESEL TANK DISPENSING OPTIONS PLEASE TURN TO PAGE 25  
FOR STANDARD ADBLUE TANK DISPENSING KIT PLEASE SEE PAGE 61



# HIGHWAY DIESEL BOWSERS WITH ADBLUE STORAGE

FOR STORING, TRANSPORTING AND DISPENSING BOTH DIESEL AND ADBLUE

## TECHNICAL DETAILS

CAPACITY	LENGTH (MM)	WIDTH (MM)	HEIGHT (MM)	EMPTY WEIGHT (KG)	FULL WEIGHT (KG)	STEEL THICKNESS INNER TANK (MM)	STEEL THICKNESS OUTER TANK (MM)	DIESEL CABINET		ADBLUE CABINET	
								MAX. HOSE LENGTH (M)	CABINET DEPTH (MM)	MAX. HOSE LENGTH (M)	CABINET DEPTH (MM)
1,000L DIESEL 200L ADBLUE	3,214	1,730	1,609	855	1933	3	3	6*	480	4	-
1,800L DIESEL 200L ADBLUE	3,717	1,800	1,773	1250	2950	3	4	6*	460	4	-

\* Extended cabinet option is available if longer hose length is required (see page 52)



HIGHWAY COMPLIANT LIGHTING / TOUGH, GALVANISED MUDGARDS



4 X SIGHT GLASS ON ADBLUE TANK FOR LEVEL READING

### INNER TANK CONNECTIONS (DIESEL TANK)

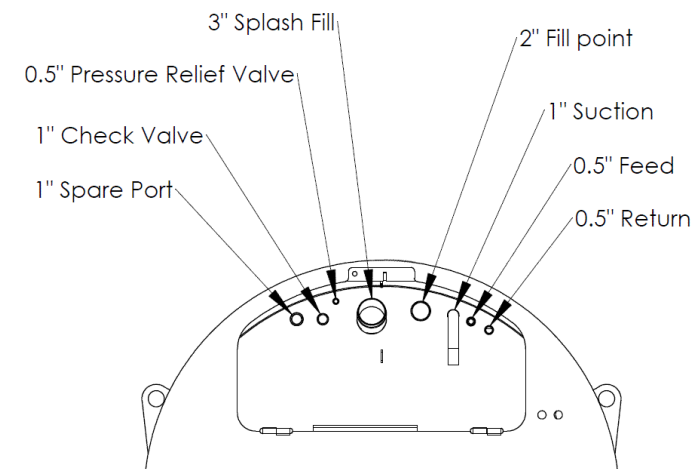

## STANDARD COLOUR:

ANTHRACITE  
GREY

RAL7016

020

For full details on colour options, codes and lead times please turn to **page 67**



# HIGHWAY DIESEL BOWSERS WITH ADBLUE STORAGE

STANDARD ADBLUE DISPENSING PACKAGE

PACKAGE CODE	PUMP	HOSE	TRIGGER	LEVEL GAUGE		
<p><b>AB010</b> PRICE: INCLUDED</p>						
	<p>12V 35 LITRE/MIN PUMP 2080-000</p>	<p>4M X ADBLUE HOSE 2080-020</p>	<p>AUTOMATIC ADBLUE NOZZLE 2080-015</p>	<p>UNITOP LEVEL GAUGE 2580-030</p>		



# SITE DIESEL BOWSERS WITH ADBLUE STORAGE

FOR STORING, TRANSPORTING AND DISPENSING BOTH DIESEL AND ADBLUE



8000 LITRE SITE DIESEL BOWSER C/W 1000L ADBLUE TANK



STAINLESS STEEL ADBLUE TANK / LOCKABLE DOOR



HIGH QUALITY DIESEL & ADBLUE DISPENSING EQUIPMENT



SECURE FULL HEIGHT CABINET HOUSES TANK CONNECTIONS AND DUAL DISPENSING SYSTEMS FOR DIESEL AND ADBLUE

## OVERVIEW

Our range of Diesel+AdBlue site towable bowers are an all-in-one unit built to store, transport and dispense both Diesel and AdBlue. These units feature an all-steel construction with 110% banded Diesel tank, stainless steel AdBlue tank, twin dispensing systems and an integral chassis with heavy-duty running gear and large flotation tyres for rough terrain. These bowers are fully compliant with current regulations, and are ideal for applications where both Diesel and AdBlue need to be transported around sites.

## KEY FEATURES

- ▶ Fully compliant with current environmental regulations
- ▶ All-steel construction and reinforced, integral chassis
- ▶ Dual storage: 110% banded Diesel tank & stainless-steel AdBlue tank
- ▶ Baffled inner diesel tank ensuring excellent stability
- ▶ Dual dispensing systems - one for each tank
- ▶ Choice of pump options to match your machines, vehicles & application
- ▶ Secure full height cabinet for access to dispensing equipment and tank connections
- ▶ Access steps and galvanised refuelling platform (6,000 and 8,000 litre models only)
- ▶ Manway for tank cleaning and inspection
- ▶ Heavy duty running gear and steel mudguards
- ▶ Hydraulic brakes
- ▶ Shot blasted to SA 2.5 and painted in 2-pack polyurethane finish
- ▶ 3 year warranty for peace of mind

## PRODUCT CODES / PRICES

CAPACITY	CODE
4,000L DIESEL / 500L ADBLUE	0445
6,000L DIESEL / 1000L ADBLUE	0462
8,000L DIESEL / 1000L ADBLUE	0465

Note: Above prices do not include Diesel dispensing equipment. Standard AdBlue dispensing kit (p.65) is included

FOR DIESEL TANK DISPENSING OPTIONS PLEASE TURN TO PAGE 35  
FOR STANDARD ADBLUE TANK DISPENSING KIT PLEASE SEE PAGE 65

# SITE DIESEL BOWSERS WITH ADBLUE STORAGE

FOR STORING, TRANSPORTING AND DISPENSING BOTH DIESEL AND ADBLUE

## TECHNICAL DETAILS

CAPACITY	LENGTH (MM)	WIDTH (MM)	HEIGHT (MM)	EMPTY WEIGHT (KG)	FULL WEIGHT (KG)	STEEL THICKNESS INNER TANK (MM)	STEEL THICKNESS OUTER TANK (MM)	DIESEL CABINET		ADBLUE CABINET	
								MAX. HOSE LENGTH (M)	CABINET DEPTH (MM)	MAX. HOSE LENGTH (M)	CABINET DEPTH (MM)
4,000L DIESEL 500L ADBLUE	5,520	2,350	2,350	2,995	6,961	5	4	12	818	4	256
6,000L DIESEL 1000L ADBLUE	5,875	2,687	2,665	3,902	9,823	5	5	12	908	4	502
8,000L DIESEL 1000L ADBLUE	6,733	2,739	2,871	4,195	11,816	5	5	12	829	4	502



FOLD DOWN STEP FOR ACCESS TO DIESEL DISPENSING CABINET



HIGH FLOW DIESEL ENGINED PUMP OPTION ON DIESEL TANK

### DIESEL TANK CONNECTIONS

- ▶ Rotary tank contents gauge
- ▶ 3" BSP fill point
- ▶ 2" BSP fill point
- ▶ 2" suction line with overfill

### ADBLUE TANK CONNECTIONS

- ▶ 2" BSP fill point

## STANDARD COLOUR:

ANTHRACITE  
GREY

RAL7016

020

For full details on colour options, codes and lead times please turn to **page 67**



# SITE DIESEL BOWSERS WITH ADBLUE STORAGE

## STANDARD ADBLUE DISPENSING PACKAGE

\*ONLY APPLICABLE TO PETROL/HYDRAULIC PUMPS

PACKAGE CODE	PUMP	HOSE	TRIGGER	LEVEL GAUGE	BATTERY*	SOLAR PANEL*
<b>AB010</b> PRICE: INCLUDED						
	12V 35 LITRE/MIN PUMP 2080-000	4M X ADBLUE HOSE 2080-020	AUTOMATIC ADBLUE NOZZLE 2080-015	UNITOP LEVEL GAUGE 2580-030		
<b>AB011</b>						
	12V 35 LITRE/MIN PUMP 2080-000	4M X ADBLUE HOSE 2080-020	AUTOMATIC ADBLUE NOZZLE 2080-015	UNITOP LEVEL GAUGE 2580-030	12V BATTERY / CARRIER 2550-040	20W 12V SOLAR PANEL 2560-102
<b>AB012</b>  *UNABLE TO ACCOMMODATE HOSE REEL IN 4,500L						
	12V 35 LITRE/MIN PUMP 2080-000	10M X 3/4" DIESEL HOSE WITH RETRACTABLE REEL*	AUTOMATIC ADBLUE NOZZLE 2080-015	UNITOP LEVEL GAUGE 2580-030		
<b>AB013</b>  *UNABLE TO ACCOMMODATE HOSE REEL IN 4,500L						
	12V 35 LITRE/MIN PUMP 2080-000	10M X 3/4" DIESEL HOSE WITH RETRACTABLE REEL*	AUTOMATIC ADBLUE NOZZLE 2080-015	UNITOP LEVEL GAUGE 2580-030	12V BATTERY / CARRIER 2550-040	20W 12V SOLAR PANEL 2560-102



# COLOUR OPTIONS

**FUELCUBES  
GENERATOR TANKS  
FUELSTORES  
HIGHWAY BOWSERS  
SITE BOWSERS**

**SHORTEST  
LEAD TIME**

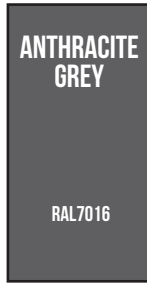

**020**

← **ADDITIONAL 10 DAYS LEAD TIME** →



**010**



**040**



**060**



**080**



**100**

**ADDITIONAL 14 DAYS  
LEAD TIME**



**500**

**£100 charge per unit**  
*Customer must provide RAL code*

## BULK TANKS

← **SHORTEST LEAD TIME** →



**020**



**060**



**010**



**040**



**080**



**100**

**ADDITIONAL 14 DAYS  
LEAD TIME**



**500**

*Customer must provide RAL code*



**Please Note:**

*All information and images in this brochure are for illustrative purposes only. Technical details are included as a guide and should be treated as approximate values. Confirmation of exact figures can be given at time of order and during any subsequent design period.*



*FUEL PROOF LTD  
MIDDLETON BUSINESS PARK  
MIDDLETON ROAD  
HEYSHAM  
LANCASHIRE  
LA3 3FH*

*TEL: +44 (0)1524 850685  
FAX: +44 (0)1524 850685  
WEB: WWW.FUELPROOF.CO.UK  
E-MAIL: INFO@FUELPROOF.CO.UK*