

DMS technologies

**HAWKER CYCLON
VALVE REGULATED LEAD ACID BATTERY**

Application Manual



Revised July 2004

ENGINEERING WITH ENERGY

HAWKER CYCLON

VALVE REGULATED LEAD ACID BATTERY

Application Manual



Introduction	Page 4
Performance Characteristics	Page 4
Storage	Page 5
Charging	Page 5
Service Life	Page 6
Safety Precautions, Disposal and Transportation	Page 7
Discharge Characteristics	Page 7
Cyclon 2V Single Cell Technical Specifications	Page 9
Cyclon Battery Packs	Page 10
Cyclon 4V Monobloc Technical Specifications	Page 12
Cyclon 6V Monobloc Technical Specifications	Page 13
Cyclon Monobloc Dimensions	Page 14
Cyclon Monobloc Configurations	Page 15

Introduction to Cyclon Cells and Monoblocs

Cyclon Valve Regulated Lead Acid (VRLA) Cells and Monoblocs utilise a unique technology using wound electrodes made of pure lead (99.99%) alloyed with 0.65% of tin.

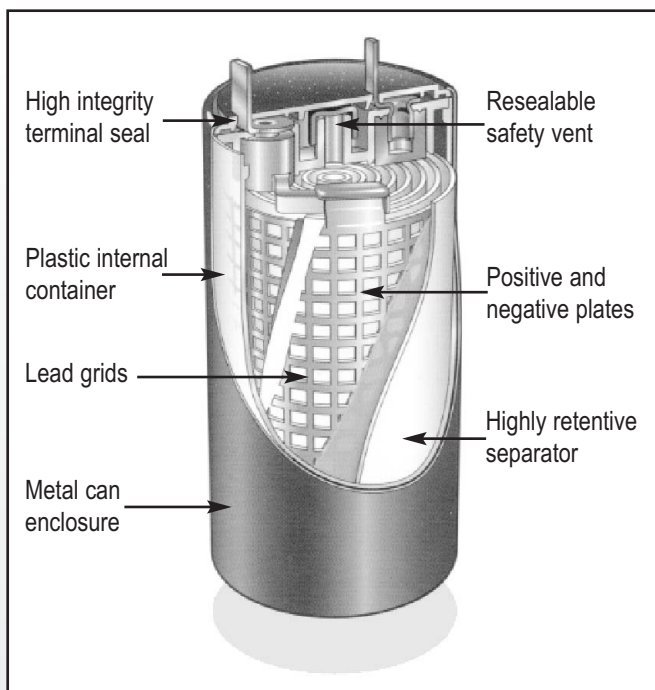

Gasses produced in normal overcharge are recombined within the cell. A re-sealable bunsen valve is incorporated to permit gas venting in the case of abusive overcharge.

Both Cyclon Cells and Cyclon Monoblocs can be charged and discharged in any attitude.

Both Cells and Monoblocs can be assembled into many different configurations providing maximum design flexibility.

Product can be transported by land, sea and air as non-hazardous cargo. Cyclon Cells are a recognised component meeting UL924 and UL1778. Cyclon Monoblocs meet UL924.

Performance Characteristics

Cyclon Cells and Monoblocs have outstanding performance in the following areas.

- Long float life - Cyclon Cells: 15 years at 20°C.
- Cyclon Monoblocs: 10 years at 20°C
- Long storage life (greater than 2 years at 25°C before recharge is necessary).
- Exceptional high rate discharge (Up to 26C).
- Wide operating temperature range
- Cyclon Cells -65°C to +80°C
- Cyclon Monoblocs -40°C to +40°C
- Very high shock and vibration resistance in all planes.
- Cycle life up to 5000 cycles at 10% DOD.

Discharge Characteristics

Maximum current capabilities

Cyclon Type	Pulse Amps	Continuous Amps
D Single Cell (2.5 Ah)	200	65
D Monobloc (2.5 Ah)	200	50
TD Single Cell (4.5 Ah)	200	65
X Single Cell (5.0 Ah)	285	65
X Monobloc (5.0 Ah)	285	50
E Single Cell (8.0 Ah)	330	65
E Monobloc (8.0 Ah)	330	50
J Single Cell (12 Ah)	400	100
BC Single Cell (25.0 Ah)	665	250

Table 1

The extremely low internal resistance of Cyclon cells gives excellent voltage regulation on discharge which is equal to or better than other VRLA systems.

As with all lead battery systems discharge energy available is reduced as temperature decreases.

Variation of discharge capacity with temperature.

% of rated C/10 Capacity Available

Temp °C	C/10	C
80	105	75
60	105	75
40	105	75
20	100	72
0	85	65
-20	70	50
-40	50	30

Table 2

These values should be taken as a guide only.

If the application fully discharges the battery it is recommended that a low voltage cut-out is employed to protect the battery against overdischarge. The end of discharge voltage varies according to the rate of discharge (See Table 3). Overdischarging the battery can lead to recharging difficulties and also damage the battery. For design details of low voltage cut-out circuits please contact our Customer Support Staff on +44 (0) 1794 525463.

Recommended minimum End of Discharge Voltage (EODV).

Discharge Rate Amps	Min. EODV per cell
0.05C (C/20)	1.75V
0.10C (C/10)	1.70V
0.20C (C/5)	1.65V
0.40C (C/2.5)	1.65V
1.00C	1.60V
2.00C	1.55V
>5.00C	1.50V

Discharging the Cyclon cell below these voltage levels or leaving the cell connected to a load in a discharged state may impair the cell's ability to accept a charge.

Table 3

Storage

The state of charge of the Cyclon cell can be estimated by using the graph below.

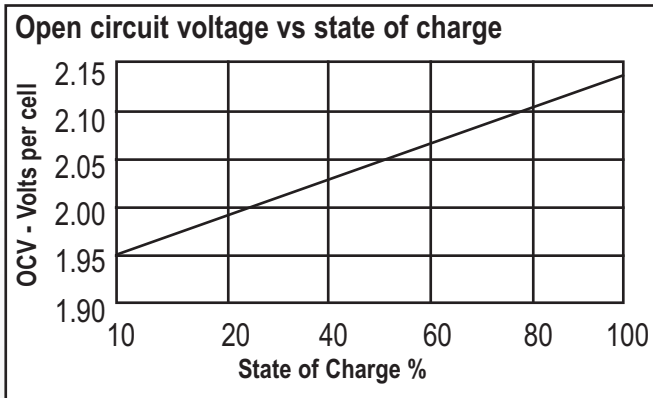

Table 4

Note:- This curve is accurate to within 20% of the cell's rated capacity, if it has not been charged or discharged within the past 24 hours. The curve is accurate to within 5% if the cell has not seen any activity, charge or discharge, for the past 5 days.

Storage

Most batteries lose their stored energy when allowed to stand open circuit. The self discharge rate is dependent both on the system's chemistry and on the temperature at which the battery is stored. Lead-tin technology gives the lowest self discharge and the longest shelf life of any VRLA battery system. Storage life is shown in Table 5 and is dependent on temperature.

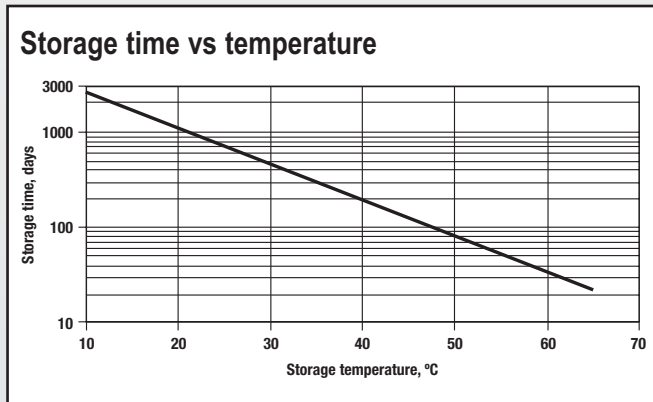

Table 5

Cyclon's self discharge rate is non linear. Table 6 indicates capacity remaining against time.

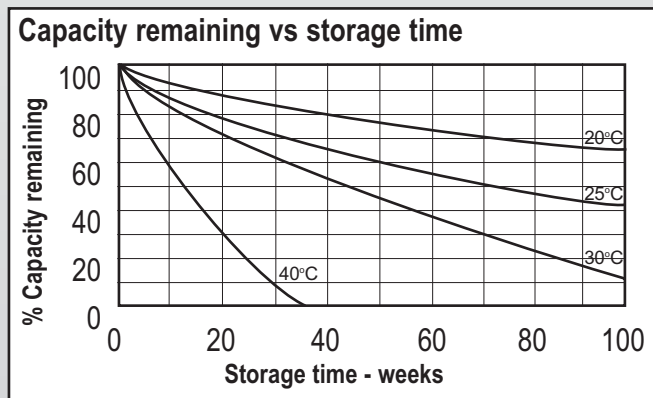

Table 6

Charging

Constant Voltage Charging is the most efficient method of charging Cyclon VRLA products.

To obtain full recharge and maintain the capacity of the cell it is necessary to return a minimum of 110% of the energy that has been removed during the last discharge. Correct voltage setting and good voltage regulation of the charger are essential to maintain an acceptable battery life. Fast recharge is possible with Cyclon products although for economic reasons batteries are usually recharged at the C/10 or C/5 rate.

Voltage levels differ for float and cyclic applications.

The table below shows the correct charger voltage setting for both cyclic and float applications.

Charge Voltages

Float charge = 2.25-2.30V per cell at 25°C

Cyclic charge = 2.45-2.5V per cell at 25°C

Recharge Time

Cyclon products can be recharged to 95% capacity in under one hour. No current limit is necessary at either float or cyclic voltages. If a fast charge regime is used it is necessary to allow a longer period of recharge (typically 7 to 10 hours) every 7-10 cycles. This permits cells to fully recharge and ensures a maximum cycle life.

Charger Rating	Typical recharge time in hours for different current rating chargers at 25°C			
	Charge Voltage			
	2.3VPC (Float)		2.45VPC (Cyclic)	
	90% Rech.	100% Rech.	90% Rech.	100% Rech.
5C	-	-	0.5	7
C	-	-	1.5	8
C/5	7	45	6	16
C/10	12	50	11	24

Table 7

Temperature Compensation

If operating temperatures are extreme, temperature compensation should be applied to the charging voltage as shown below.

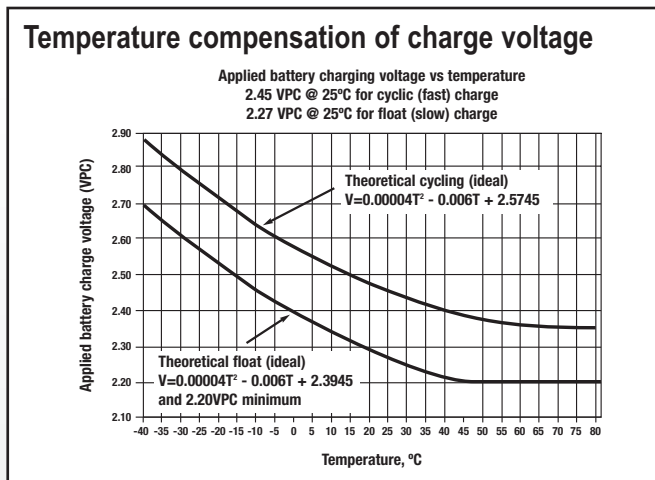

Table 8

Two Stage Constant Voltage Charging

To allow fast recharge but maximise standby life, switched voltage level charging can be used. Charging should commence at the cyclic rate and switch down to the float charge voltage after a preset time has elapsed. The time is established with reference to the charge current limit (See Table 7 page 5).

Constant Current Charging

This technique can be used with Cyclon cells and Monoblocs providing charging is terminated before excessive overcharge occurs. Charge can be terminated by time or voltage sensing but long term overcharge must be limited to C/500. Please contact our Customer Support Staff for further assistance.

Taper Charging

Although taper current chargers are the least expensive type of chargers, their lack of voltage regulation can be detrimental to the life of any cell type. Half wave rectification should be avoided because the high peak-to-average voltage ratio will reduce the service life of the cell. It is recommended that charge rate at 2.50 volts/cell be between C/50 and C/100 to prevent serious overcharge if the charger is left connected for extended periods.

The normal recharge time for a taper charger can be assessed by reference to the charge current available at charge voltage of 2.2VPC allowing for the return of 120% of discharged capacity.

Other Charging Methods

For application engineering support on solar, vehicle systems or other charging methods please refer to our Customer Support Staff.

Service Life

End of service life of Cyclon products is defined as the point when the battery delivers less than 80% of its rated capacity.

Float Life

Cyclon cells have a design life of 15 years at 20°C for float applications.

Cyclon Monoblocs have a design life of 10 years at 20°C for float applications.

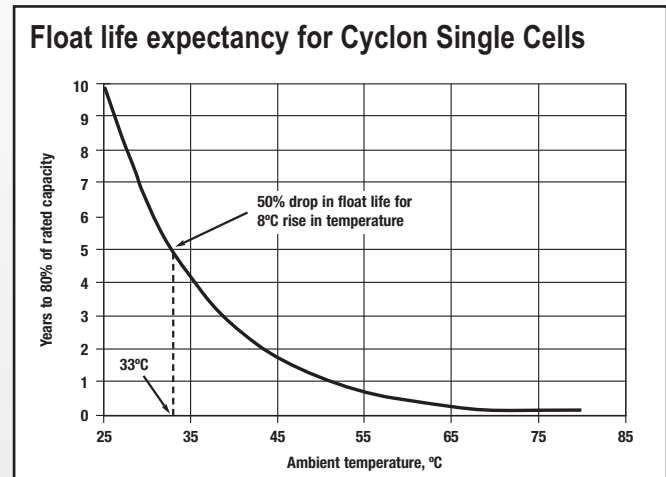

Table 9

Cycle Life

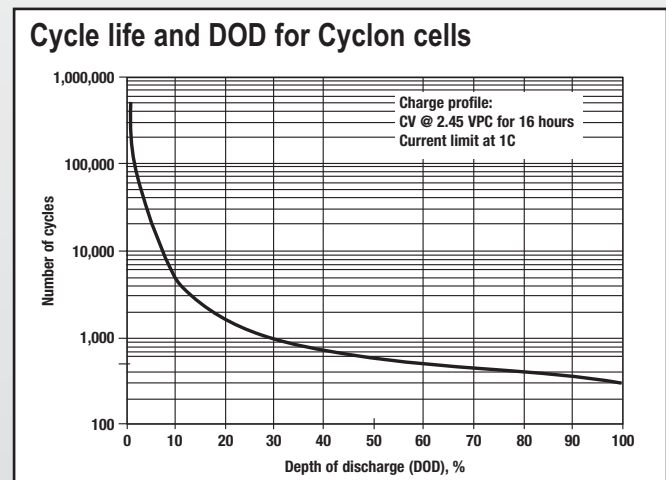

Table 10

N.B. Service life is dependent on correct charging of the product and operating temperature.

Safety Precautions, Disposal and Transportation

Safety Precautions

1. Recombination technology is designed to contain and recombine gas produced in overcharge. In certain circumstances such as abusive overcharge gasses can be vented through the safety valve. To prevent any possibility of explosion.

Never charge in a gas tight container

2. Pure lead/tin batteries have a very low internal impedance and are capable of delivering very high currents if short circuited. The resultant heat could cause severe burns or a fire.

Do not short circuit cells or batteries

3. To ensure correct service life and operation.

Use approved charging methods

Disposal

Cyclon products contain materials capable of being recycled and should be disposed of according to the laws governing the recycling of lead products.

Transportation

All Cyclon products are classified as non-spillable wet electric storage batteries and can be shipped by land, sea and air as non-hazardous cargo.

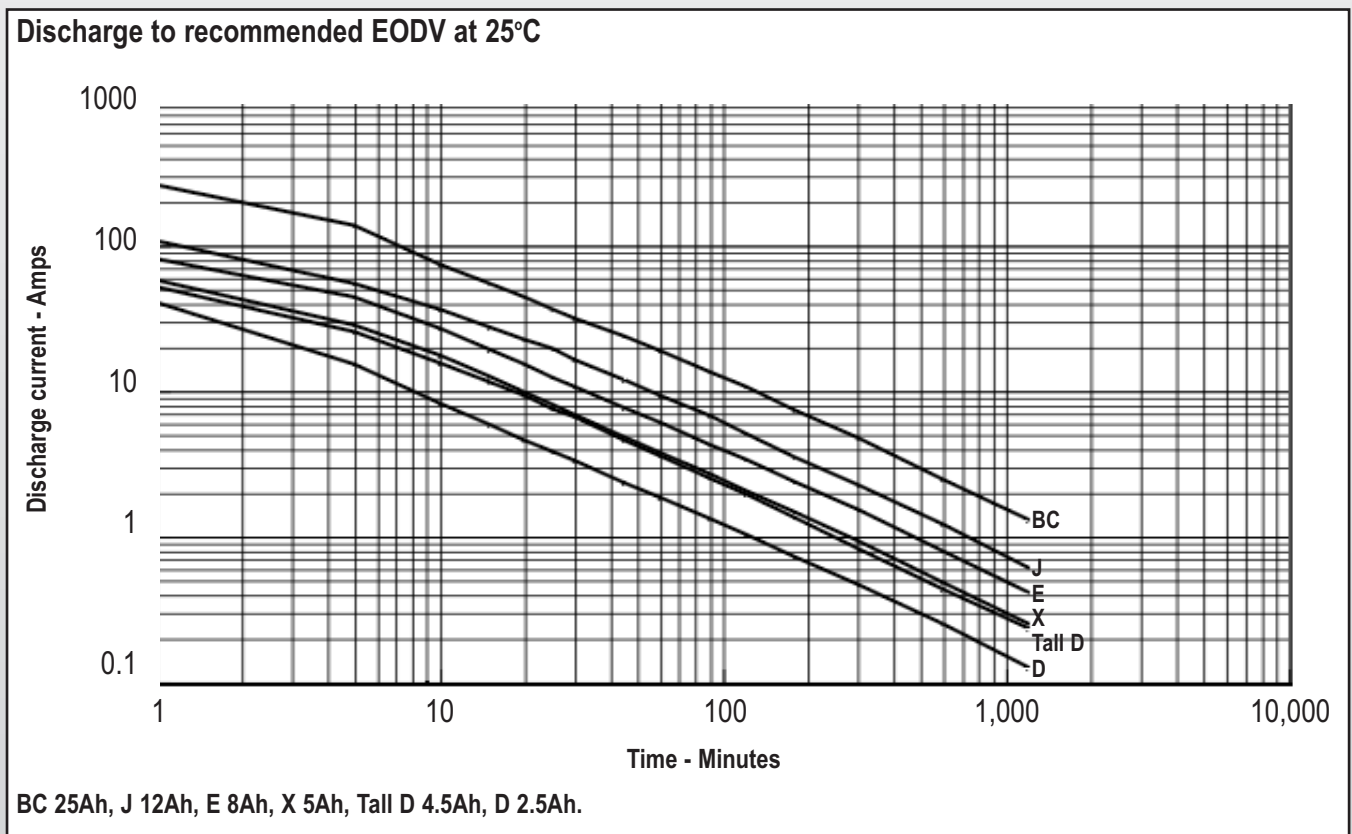

Table 11

Tabular Discharge Data

Cyclon 2V, 2.5Ah D cell and D monobloc
Discharge: Constant Current (Amps) at 25°C

Run Time	1.85VPC	1.75VPC	1.67VPC	1.60VPC	1.50VPC
1 min	21.20	30.10	34.60	38.10	41.60
5 min	10.40	13.50	14.30	15.40	15.80
10 min	6.60	7.70	8.10	8.30	8.40
15 min	5.00	5.60	5.90	5.97	6.04
20 min	4.00	4.50	4.60	4.70	4.75
25 min	3.40	3.80	3.90	3.93	X
30 min	2.90	3.30	3.35	3.40	X
45 min	2.20	2.40	2.42	X	X
60 min	1.75	1.90	1.92	X	X
90 min	1.25	1.34	1.37	X	X
2 hr	1.00	1.05	1.07	X	X
3 hr	0.70	0.74	0.75	X	X
5 hr	0.45	0.47	0.48	X	X
10 hr	0.24	0.25	0.26	X	X
20 hr	0.12	0.13	0.13	X	X

Table 12

Cyclon 2V, 8.0Ah E cell and E monobloc.
Discharge: Constant Current (Amps) at 25°C

Run Time	1.85VPC	1.75VPC	1.67VPC	1.60VPC	1.50VPC
1 min	46.00	60.50	69.50	72.20	81.00
5 min	31.30	38.00	41.70	44.00	45.67
10 min	20.20	24.40	26.40	27.10	27.70
15 min	15.90	18.30	19.00	19.40	19.70
20 min	13.00	14.70	15.20	15.50	15.60
25 min	11.10	12.30	12.70	12.90	X
30 min	9.70	10.70	11.00	11.10	X
45 min	7.10	7.70	7.90	X	X
60 min	5.67	6.10	6.20	X	X
90 min	4.10	4.38	4.40	X	X
2 hr	3.20	3.40	3.50	X	X
3 hr	2.30	2.40	2.46	X	X
5 hr	1.45	1.50	1.56	X	X
10 hr	0.75	0.80	0.81	X	X
20 hr	0.40	0.41	0.42	X	X

Table 15

Cyclon 2V, 4.5Ah TD cell.
Discharge: Constant Current (Amps) at 25°C

Run Time	1.85VPC	1.75VPC	1.67VPC	1.60VPC	1.50VPC
1 min	31.00	42.00	49.50	53.20	57.80
5 min	17.70	20.60	22.80	25.50	26.20
10 min	12.40	13.90	14.90	16.00	16.10
15 min	9.70	10.60	11.20	11.80	11.90
20 min	8.00	8.60	9.10	9.40	9.50
25 min	6.70	7.20	7.60	7.80	X
30 min	5.90	6.30	6.60	6.80	X
45 min	4.30	4.60	4.70	X	X
60 min	3.40	3.60	3.70	X	X
90 min	2.40	2.50	2.60	X	X
2 hr	1.90	1.90	2.00	X	X
3 hr	1.30	1.30	1.40	X	X
5 hr	0.82	0.84	0.85	X	X
10 hr	0.43	0.44	0.45	X	X
20 hr	0.22	0.23	0.34	X	X

Table 13

Cyclon 2V 12Ah J cell.
Discharge: Constant Current (Amps) at 25°C

Run Time	1.85VPC	1.75VPC	1.67VPC	1.60VPC	1.50VPC
2 min	33.5	49.6	63.3	74.0	82.9
5 min	32.2	40.6	47.1	51.8	55.8
10 min	25.9	30.1	33.2	35.4	37.2
15 min	21.4	24.1	26.0	27.3	28.4
20 min	18.3	20.1	21.4	22.3	23.1
25 min	16.25	17.7	18.7	19.4	20.1
30 min	14.2	15.3	16.0	16.5	17.0
45 min	10.7	11.3	11.7	12.0	12.3
60 min	8.6	9.0	9.3	9.5	9.6
90 min	6.7	7.0	7.2	7.3	X
2 hr	4.8	5.0	5.1	5.2	X
3 hr	3.4	3.5	3.6	X	X
5 hr	2.1	2.2	2.3	X	X
10 hr	1.1	1.2	X	X	X
20 hr	0.6	X	X	X	X

Table 16

Cyclon 2V 5.0Ah X cell and X monobloc
Discharge: Constant Current (Amps) at 25°C

Run Time	1.85VPC	1.75VPC	1.67VPC	1.60VPC	1.50VPC
1 min	33.60	44.20	50.70	54.90	59.20
5 min	20.00	24.90	27.30	28.30	29.00
10 min	13.40	16.60	17.80	18.40	18.80
15 min	10.20	12.30	13.20	13.60	13.80
20 min	8.20	9.60	10.00	10.20	10.30
25 min	7.00	7.90	8.20	8.30	X
30 min	6.10	6.80	7.00	7.10	X
45 min	4.40	4.90	5.00	X	X
60 min	3.50	3.80	3.90	X	X
90 min	2.50	2.70	2.75	X	X
2 hr	2.00	2.10	2.14	X	X
3 hr	1.40	1.48	1.51	X	X
5 hr	0.90	0.95	0.96	X	X
10 hr	0.47	0.50	0.50	X	X
20 hr	0.24	0.24	0.26	X	X

Table 14

Cyclon 2V 25.0Ah BC cell.
Discharge: Constant Current (Amps) at 25°C

Run Time	1.85VPC	1.75VPC	1.67VPC	1.60VPC	1.50VPC
1 min	122.90	167.20	199.00	235.00	268.50
5 min	78.90	102.20	118.30	130.50	141.20
10 min	58.10	68.50	72.80	74.70	76.40
15 min	45.60	52.30	54.30	55.30	56.20
20 min	37.70	42.30	43.70	44.40	45.10
25 min	32.80	35.90	36.90	37.40	X
30 min	29.20	31.60	32.00	32.60	X
45 min	22.00	24.00	24.40	X	X
60 min	17.75	18.90	19.30	X	X
90 min	13.10	13.80	14.00	X	X
2 hr	10.20	10.90	11.10	X	X
3 hr	7.10	7.50	7.60	X	X
5 hr	4.60	4.80	4.85	X	X
10 hr	2.40	2.50	2.55	X	X
20 hr	1.25	1.32	1.33	X	X

Table 17

X indicates that the cell should not be discharged at this rate to the specified EODV.

Cyclon 2V Single Cell Technical Specifications at 25°C

Cell type	Product Number	Volts	Nominal Capacity (10hr rate to 1.67VPC) (Ah)	Dimensions(mm)			Weight (Kg)	Tabs (mm)
				Dia	Ht	Ht over tabs		
D cell (2.5Ah)	9810-0004	2	2.5	34	61	68	0.2	4.75x0.64
Tall D cell (4.5Ah)	9860-0004	2	4.5	34	96	103	0.3	4.74x0.64
X cell (5.0Ah)	9800-0004	2	5.0	44	73	82	0.4	6.35x0.64
E cell (8.0Ah)	9850-0004	2	8.0	44	100	109	0.6	6.35x0.64
J cell (12Ah)	9840-0004	2	12.0	52	123	136	0.8	7.92x0.81
BC cell (25Ah)	9820-0004	2	25.0	65	159	174	1.7	M8+M6- studs

Table 18

	D Cell	Tall D Cell	X Cell	E Cell	J cell	BC cell
Internal resistance of fully charged cell (m Ω)	5.0	5.0	3.5	3.0	2.5	1.5
Nominal short circuit current for charged cell	400A	400A	570A	665A	800A	1335A

Temperature Range

Storage	-65°C to +80°C
Discharge	-65°C to +80°C
Charge	-40°C to +80°C

Maximum recommended storage time before recharge 24 months @ 25°C or 2.0VPC, whichever is earlier. Stock should be checked at 6 month intervals or more frequently if the temperature exceeds +25°C

Safety Pressure Release Valve 50 psi (all cells) 3 atmospheres

Atmospheric Pressure Range Vacuum to 8 atmospheres

Life expectancy (to 80% of rated capacity)

Cycle Life (100% DOD, C/5)	300
Cycle life (5% DOD)	10,000
Float Life at 25°C	10 years
Float life at 20°C	15 years

Charging

Constant Voltage (Cyclic) 2.45-2.50VPC
 Constant Voltage (Floating) 2.25-2.30VPC
 N.B. No current limit is required when using a voltage regulated charger.
 Constant Current charging - please contact DMS for specific data.

Caution

Batteries contain toxic materials (Lead, Sulphuric Acid).

Avoid short circuit.

Do not charge in gas tight container.

Must be recycled or disposed of properly.

Cyclon Battery Packs

Product Number	Description	Dimensions (mm)			Weight (Kg)
		L	W	H	
9810-0075	12V 2.5Ah 1x6 ABS Leads	209	39	68	1.19
9810-0016	12V 2.5Ah 1x6 ABS Tags	209	39	68	1.19
9810-0109	12V 2.5Ah 1x6 s/w Leads	203	38	67	1.13
9810-0108	12V 2.5Ah 1x6 s/w Tags	203	38	67	1.13
9810-0067	12V 2.5Ah 2x3 ABS Leads	107	73	68	1.19
9810-0008	12V 2.5Ah 2x3 ABS Tags	107	73	68	1.19
9810-0115	12V 2.5Ah 2x3 s/w Leads	102	72	67	1.13
9810-0114	12V 2.5Ah 2x3 s/w Tags	102	72	67	1.13
9800-0072	12V 5Ah 1x6 ABS Leads	270	49	79	2.40
9800-0016	12V 5Ah 1x6 ABS Tags	270	49	79	2.40
9800-0109	12V 5Ah 1x6 s/w Leads	264	46	78	2.35
9800-0108	12V 5Ah 1x6 s/w Tags	264	46	78	2.35
9800-0047	12V 5Ah 2x3 ABS Leads	138	93	79	2.40
9800-0008	12V 5Ah 2x3 ABS Tags	138	93	79	2.40
9800-0115	12V 5Ah 2x3 s/w Leads	133	91	78	2.35
9800-0114	12V 5Ah 2x3 s/w Tags	133	91	78	2.35
9810-0077	6V 2.5Ah 1x3 ABS Leads	107	39	68	0.60
9810-0011	6V 2.5Ah 1x3 ABS Tags	107	39	68	0.60
9810-0103	6V 2.5Ah 1x3 s/w Leads	102	38	67	0.56
9810-0102	6V 2.5Ah 1x3 s/w Tags	102	38	67	0.56
9800-0071	6V 5Ah 1x3 ABS Leads	138	49	79	1.18
9800-0011	6V 5Ah 1x3 ABS Tags	138	49	79	1.18
9800-0103	6V 5Ah 1x3 s/w Leads	133	47	78	1.12
9800-0102	6V 5Ah 1x3 s/w Tags	133	47	78	1.12

6 volt Shrink wrap.

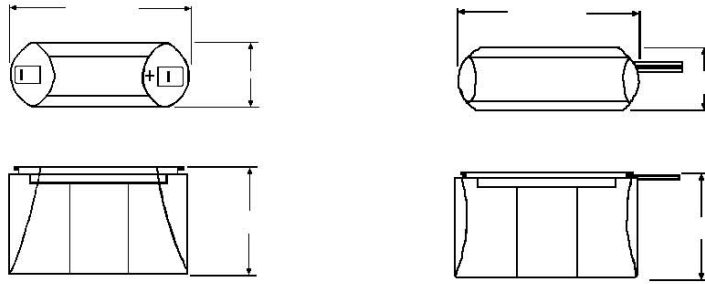

6 volt ABS case.



12 volt 1x6 Shrink wrap.

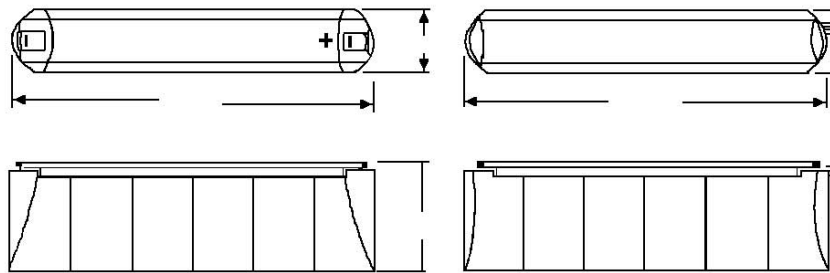

12 volt 2x3 Shrink wrap.

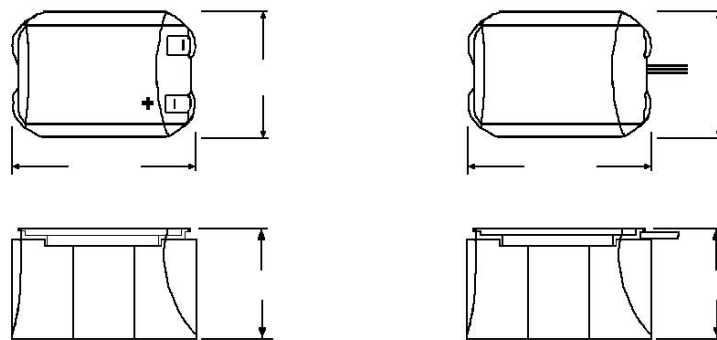

12 volt 2x3 ABS case.

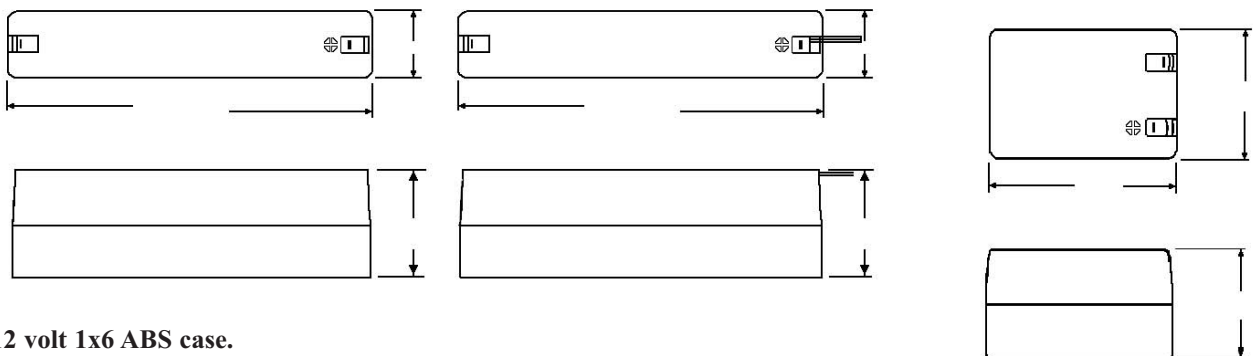

12 volt 1x6 ABS case.

Cyclon 4V Monobloc Technical Specifications

	D (2.5Ah)	X (5.0Ah)	E (8.0Ah)
Part number	9819-0010	9809-0010	9859-0010
Capacity to 1.67 vpc.			
10 hour rate	2.50Ah	5.00Ah	8.00Ah
1 hour rate	1.95Ah	3.99Ah	6.24Ah
15 minute rate	1.49Ah	3.40Ah	4.75Ah
Maximum overall dimensions (mm).			
Length	79.5	96.5	96.8
Width	46.0	53.8	54.1
Height	69.85	76.71	101.60
Weight (kg)	0.36	0.74	0.96
Internal resistance of fully charged monobloc, mΩ at 25°C.	10.0	7.0	6.0
Nominal battery voltage	4.0	4.0	4.0
Nominal short circuit level for charged battery	400A	570A	665A
Temperature range			
Storage	-40°C to +40°C	-40°C to +40°C	-40°C to +40°C
Discharge	-40°C to +40°C	-40°C to +40°C	-40°C to +40°C
Charge	-40°C to +40°C	-40°C to +40°C	-40°C to +40°C
Maximum recommended storage time before recharge	24 months @ 25°C or 2.0vpc, whichever is earlier.		
Safety pressure relief valve	8psi 0.5Atm	8psi 0.5Atm	8psi 0.5Atm
Atmospheric pressure range	Vacuum to 2 atmospheres		
Charging, per 4V battery at 25°C			
Constant voltage (cyclic)	4.90 to 5.0	4.90 to 5.0	4.90 to 5.0
Constant voltage (float)	4.50 to 4.60	4.50 to 4.60	4.50 to 4.60
N.B. No current limit is required when using a voltage regulated charger. Constant Current charging - please contact DMS for specific data.			
Life expectancy (to 80% of rated capacity)			
Cycle Life, 100% DOD, C/5	300*	300*	300*
Float life at 20°C, based on accelerated test methods, 4.50 volts constant voltage charge at 20°C ambient temperature	10 years	10 years	10 years
Mounting	Each monobloc is equipped with 0.216 in./5.49mm mounting holes in the cover. The tightening torque for mounting the monobloc is 25in-lbs. When using 4 mounting bolts, small spacers (washers) 1 to 3mm thick should be placed between the battery and the mounting surface to prevent bowing or stressing the battery case.		
UL Recognised component. Meets UL 924			

*300 cycles at 100% depth of discharge; one cycle per, C/5 (Charge: 5.0V constant voltage, 3C current limit; 16 hour charge).

Cyclon 6V Monobloc Technical Specifications

	D (2.5Ah)	X (5.0Ah)	E (8.0Ah)
Part number	9819-0012	9809-0012	9859-0012
Capacity to 1.67 vpc.			
10 hour rate	2.50Ah	5.00Ah	8.00Ah
1 hour rate	1.95Ah	3.99Ah	6.24Ah
15 minute rate	1.49Ah	3.40Ah	4.75Ah
Maximum overall dimensions (mm).			
Length	113.03	138.94	138.94
Width	45.47	53.59	53.59
Height	69.85	76.71	101.60
Weight (kg)	0.52	0.98	1.43
Internal resistance of fully charged monobloc, mΩ at 25°C.	15.0	10.0	8.0
Nominal battery voltage	6.0	6.0	6.0
Nominal short circuit level for charged battery	400A	600A	750A
Temperature range			
Storage	-40°C to +40°C	-40°C to +40°C	-40°C to +40°C
Discharge	-40°C to +40°C	-40°C to +40°C	-40°C to +40°C
Charge	-40°C to +40°C	-40°C to +40°C	-40°C to +40°C
Maximum recommended storage time before recharge	24 months @ 25°C or 2.0vpc, whichever is earlier.		
Safety pressure relief valve	8psi 0.5Atm	8psi 0.5Atm	8psi 0.5Atm
Atmospheric pressure range	Vacuum to 2 atmospheres		
Charging, per 6V battery at 25°C			
Constant voltage (cyclic)	7.35 to 7.50	7.35 to 7.50	7.35 to 7.50
Constant voltage (float)	6.75 to 6.90	6.75 to 6.90	6.75 to 6.90

N.B. No current limit is required when using a voltage regulated charger.
Constant Current charging - please contact DMS for specific data.

Life expectancy (to 80% of rated capacity)

Cycle Life, 100% DOD, C/5	300*	300*	300*
Float life at 20°C, based on accelerated test methods, 6.75 volts constant voltage charge at 20°C ambient temperature	10 years	10 years	10 years

Mounting

Each monobloc is equipped with 0.216 in./5.49mm. mounting holes in the cover. The tightening torque for mounting the monobloc is 25in-lbs.
When using 4 mounting bolts, small spacers (washers) 1 to 3mm thick should be placed between the battery and the mounting surface to prevent bowing or stressing the battery case.

UL Recognised component. Meets UL 924

*300 cycles at 100% depth of discharge; one cycle per, C/5 (Charge: 7.50V constant voltage, 3C current limit; 16 hour charge).

D Monobloc (6V)

Length mm	113
Width mm	45
Height mm	70
Weight kg	0.52
Tabs mm	4.75x0.64

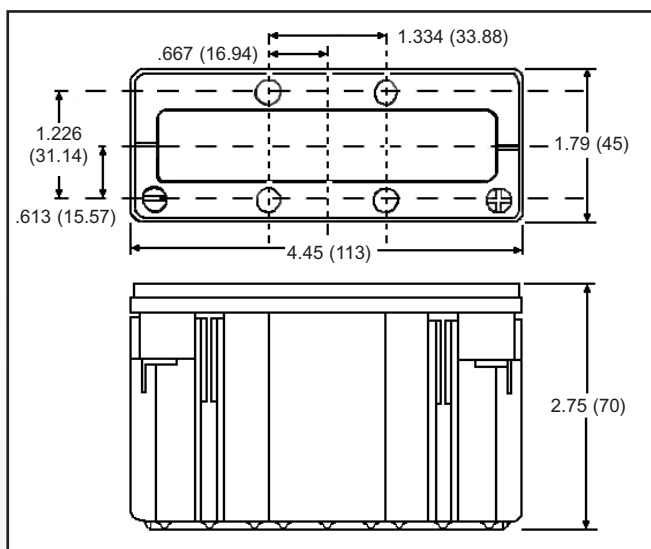

X Monobloc (6V)

Length mm	139
Width mm	54
Height mm	77
Weight kg	0.98
Tabs mm	6.35x0.64

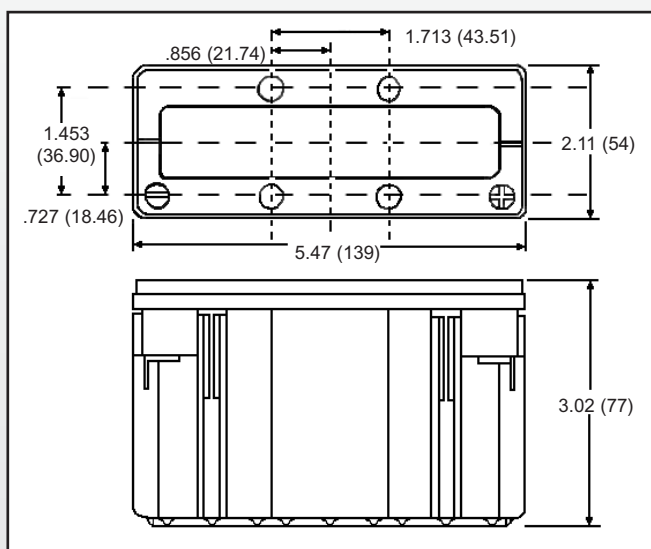

E Monobloc (6V)

Length mm	139
Width mm	54
Height mm	102
Weight kg	1.43
Tabs mm	6.35x0.64

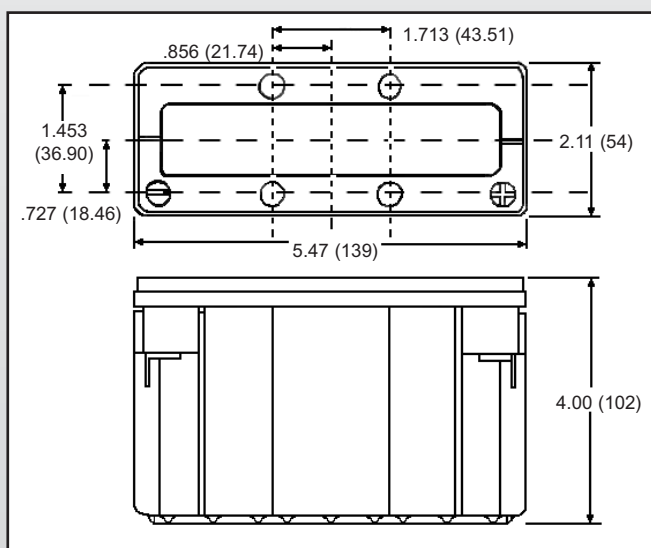

All dimensions = ins (mm).

Monobloc Configurations

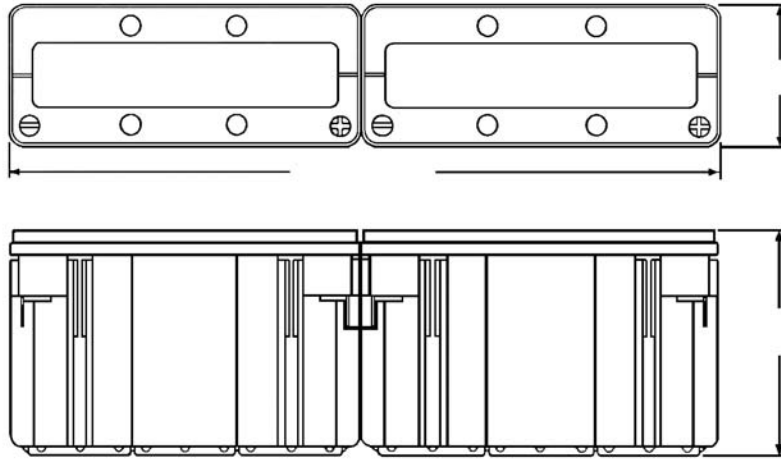

12V 1x6 and 2x3 Monobloc configurations

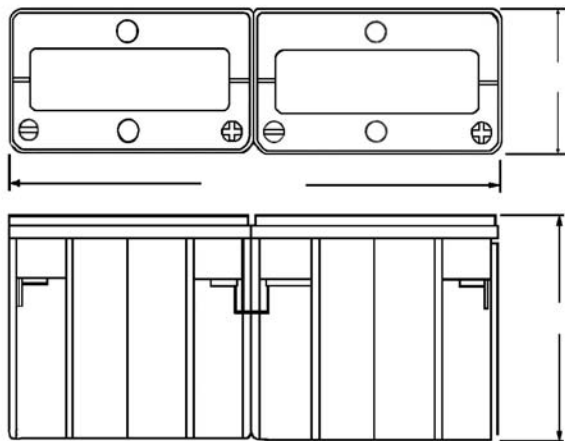
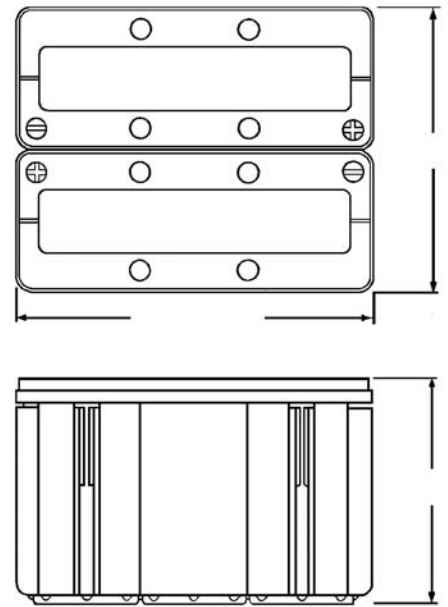

8V 1x4 and 2x2 Monobloc configurations

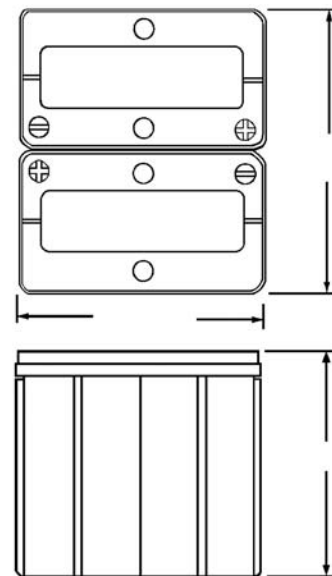

Cyclon Custom Built Power Packs



Railways

The Cyclon cell has been used for many years within the rail industry, applications powered by Cyclon include signalling systems, communications and more recently point end switching stations.

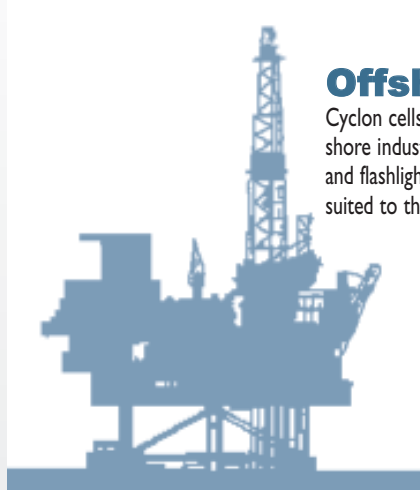
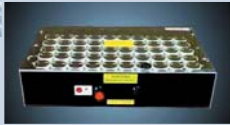

Offshore Oil & Gas

Cyclon cells are used in many products related to the offshore industry such as beacons, transponders, valve actuators and flashlights. The performance of the Cyclon cell is ideally suited to this particularly harsh environment.



Telecommunications

Cyclon battery packs are used by leaders in the communications industry for many applications. Radio base stations, line concentrators and telemetry systems are some of the most popular.



Medical Equipment

Cyclon cells are used extensively in medical equipment throughout the world in products ranging from defibrillators and monitors to pumps and portable x-rays. All require

reliable, versatile, lightweight batteries for these critical applications.



Design, Development, Manufacture and Supply of Batteries and Power Systems

DMS technologies
Belbins Business Park,
Cupernham Lane,
Romsey, Hampshire, SO51 7JF
Telephone +44 (0) 1794 525400
Fax +44 (0) 1794 525450
Email: info@dmstech.co.uk
www.dmstech.co.uk



An ISO 9001
Approved Company



Cyclon cells are manufactured by Hawker Energy Products.
Cyclon is a registered trade mark of Hawker Energy Products Inc.