



## Optima Ultrasonic Transducers



# NDT Systems

## Introduction

Thank you for your interest in the NDT Systems product line. This catalog will provide you with the information you need to select the finest Ultrasonic Transducer for your application requirements. In it you will find a summary of ultrasonic characteristics, some useful application information and technical information. If you should have any questions or require further assistance in selecting the proper transducer for your application, please do not hesitate to contact us. One of our application specialists will be glad to assist you.

For more than 26 years, NDT Systems has been a leader in bringing advanced technology ultrasonic testing products to the non-destructive testing marketplace. These products have included a variety of Ultrasonic Thickness Gages, Bond Testers, Specialized Ultrasonic Flaw Detectors as well as Ultrasonic Transducers and Eddy Current devices.

The Ultrasonic Transducer is probably the most critical component of your ultrasonic inspection. You can't receive better data than what you start with. Picture the transducer as the speakers in a high performance audio system. You have a top of the line high power receiver, CD player the best in wiring and have 3" speakers connected to the system. All the correct parts are there but... it sounds terrible. The same is true with the transducer, if you aren't using the best transducer for the application you will receive sub par results regardless of the thickness gage or flaw detector. NDT Systems remains committed to providing the finest quality in ultrasonic transducers.

There are many providers of transducers available who claim reproducible results. To some degree this is true, but the overall quality in terms of resolution and sensitivity is simply middle of the road! NDT Systems provides reproducible, High Resolution & High Sensitivity transducers.

### **Application Support and Custom Engineered Transducers**

NDT Systems manufactures a full line of standard series Ultrasonic Transducers and offers full in house capability for the design and manufacture of custom engineered probes. In fact NDT Systems offers one of the shortest lead times on custom engineered probes in the industry. Bring us your application and we will have a response and recommendation to you within 72 hours. Within this catalog you will find a few pages exhibiting just a sampling of our custom probe capability. Please give our application specialists a call.

These specialized capabilities together with the vast technological resources of NDT Systems create an unparalleled reservoir of ultrasonic testing expertise for the nondestructive testing community. Contact any representative of NDT Systems for information about the quality products and technical services available for the ideal solution to your ultrasonic NDT problems.

## About This Catalog

The OPTIMA series represents a full line of precision ultrasonic transducers designed and produced to the industry's highest standards. Hundreds of off-the-shelf models are offered to provide you with the widest choice possible for your non destructive testing needs. This catalog will provide you with helpful suggestions and recommendations which you'll find useful in matching the most appropriate transducers to a variety of common applications. Because not all questions can be answered on the few pages that follow, we invite your inquiries. We have an outstanding technical staff both in-house and in the field to provide immediate response to your questions.



# Table of Contents

## Using This Catalog

This catalog is all new in its layout in that it makes extensive use of color to clarify transducer lookup charts. Transducers of a given frequency closely follow the electronic resistor color code for chart background color. Also, the color of chart headers are kept the same where they may apply to an associated chart. For instance, a chart depicting dimensional information for fingertip contact transducers will have the same header color as the part number lookup chart for fingertip contact transducers.

The OPTIMA series represents a full line of precision ultrasonic transducers designed and produced to the industry's highest standards. Hundreds of off-the-shelf models are offered to provide you with the widest choice possible for your nondestructive testing needs.

**NDT Systems** incorporates a part numbering scheme which generally specifies each transducer in this catalog. Each transducer part number is made up of text and numbers which comprise the overall part description.

**TO ORDER OPTIMA transducers, use the Model Number from the associated tables on each page.**  
**Also note:**

The general key for the part number scheme is as follows:

H = High Damped  
F = Flaw Detection (GP)  
G = Gaging - Broadbanded (HR)  
M = Medium Damped - High Gain (HG)

Frequency = First 2 numbers

Size = Next Number(s) in 1/8" increments

TM = Top Mount Connector  
RA = Right Angle connector (standard except Immersion series)

For instance, a general purpose, contact rugged, 5 MHz & 3/4" diameter transducer would read: CHR056

- Complete standard or custom documentation certification is available. See page 6 for details.
- For cables and adaptors, see page 20.
- For test blocks, refer to page 21.

**TRANSDUCER Selection** 4-5

**TRANSDUCER Selection & Certification** 6-7

**CONTACT Transducers** 7-9

**ANGLE BEAM Transducers** 10-11

**GENERAL PURPOSE DUAL ELEMENT** 12

**NOVA SERIES DUAL ELEMENT-Probes** 13

**IMMERSION Transducer Selection** 14-15

**IMMERSION Transducers** 16-17

**NOVA Transducers** 18-19

**CABLES & ACCESSORIES** 20

**TEST BLOCKS** 21

**Custom Engineered Transducers** 22

**Other Products** 23

## General Considerations

Most ultrasonic tests are conducted in accordance with procedures that limit test parameters within rather narrow boundaries. These procedures are often developed with specific combinations of instruments and transducers.

Reference Standards, or test blocks, prove the ability of the derived procedures to detect echos from the artificial flaws by using some combination of instrument/transducer.

## The Instrument

In most practical circumstances, instrument choice is limited to what is at hand. Ultrasonic instruments are expensive, and, while offered in a range of types produced by a variety of manufacturers, most have many similar characteristics, features, and capabilities. Fortunately, it isn't usually necessary to have many different instruments in order to implement fairly diverse inspection/testing requirements. However, the same cannot be said for ultrasonic transducers.

The Transducer is the heart of any ultrasonic test. Test results are highly dependent upon many factors uniquely involving the transducer. Inappropriate transducer selection, or a poorly manufactured or malfunctioning transducer can severely effect test results regardless of instrumentation capability.

Assuming that well-trained competent personnel will perform the required ultrasonic tests using appropriate test instruments, reference standards and high quality, reliable transducer, ultimate test results boil down to a single, most important factor of selection of the most appropriate transducer(s) for the intended test or inspection.

Many factors enter into transducer selection; some are fixed, or measurable, while others may be unknown, uncontrollable, or immeasurable. The more that is known about the physical, mechanical, and geometric properties of the test object, the more precisely can the appropriate transducer(s) be selected. An exhaustive discussion of all such factors is not feasible in this guide, but consideration of the more obvious factors will help. If you have specific questions, an NDT Systems technical representative will be happy to assist you with transducer selection.

It is also helpful to have knowledge of the behavior of sound fields, both within the test object and at it's boundaries. Some of the more important considerations are related to sound beam frequency, beam spread, near and far-field effects, reflection and refraction phenomena.

## Material Factors

In metals, first consideration must be given to the metallurgical structure. Grain type, size and distribution influence the propagation of the ultrasonic sound beam. Large or directionally-oriented grains tend to scatter and otherwise absorb ultrasonic energy to a greater extent than fine, randomly-oriented grains. For instance, cast iron will be far more attenuative to ultrasound than aluminum. Some exotic materials may exhibit a directional attenuation effect.

Polymers and elastomers are often highly sound absorbing or attenuative. Reinforced plastics and other types of multi-phase and composite materials are generally attenuative and produce scattering of the sound field. Most ceramics are likewise attenuative.

Many times the geometry and surface condition of the test object are the most influencing factors in ultrasonic testing.

## Ultrasonic Sound field Factors

The vibrational frequency (or frequencies) of the transducer element determines the wavelength of the ultrasound within the test material. Combined with the geometry of the element, the frequency also establishes the extent of the near-field or natural focusing point and the amount of beam-spreading in the far-field or the points beyond the focal point.



The wavelength (as determined by choice of frequency) influences the probability that a portion of the incident sound beam will reflect from a small internal discontinuity.

The frequency/wavelength relationship depends upon the velocity of sound in the test material. The wavelength is equal to the velocity of sound in the material divided by the frequency.

If ultrasonic noise is a problem in a test procedure, generally reducing frequency reduces the noise (and, the sensitivity, in terms of detectable threshold flaw size). Also, since less reflection and scattering of the sound beam occurs at lower frequencies, the apparent attenuation decreases.

Frequency also influences the length of the near-field in the test material. Within a zone beginning immediately at the surface of a transducer, the sound field is highly irregular, having both very high and very low pressure regions. Beyond the near-field, the sound beam tends to radiate outwardly with a uniform wave-front, more or less semi-spherical in shape (assuming a circular disc shaped piezo element). In the area after the near-field, resides the so-called far-field, or the area where the sound beam diverges, and the sound field pressure, measured along the centerline of the beam, diminishes in a uniform fashion, with the inverse square of distance, neglecting attenuation losses.

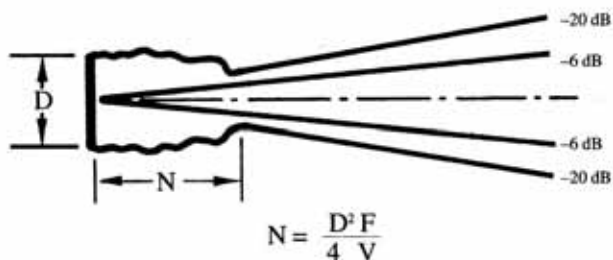

Ideally, all ultrasonic testing should be done monitoring only those echo responses within the far-field. Practically, though, much contact testing is done within the near-field. An extreme example of potential misleading information could be observed in a case where the operator used a 5MHz, 1.0" diameter probe. In this case if an alarm level were to be set in the near-field the effect of this size & frequency transducer may exhibit multiple responses or alarms to a given small defect. However, the probe would also exhibit a deeper penetration capability. Therefore, if the purpose of the inspection was to look for defects close to the surface a smaller diameter probe would be recommended. Please study the near-field or Yo chart elsewhere in this catalog for an idea of where the focal point exists for given transducer frequency and size.

Having more practical importance in immersion testing, the length of the near-field influences choices concerning the advantages of focusing and waterpath.

In transducer selection, whether contact or immersion, a further consideration involving frequency is significant. No practical transducer vibrates at a single frequency. For various applications, it is more desirable to use transducers that vibrate over as narrow a band of frequencies as possible. In other cases, broad banded transducers are more efficient.

Elements (or piezo ceramics) with no damping or very light damping will vibrate over a range of frequencies close to the natural, resonant frequency of the element. Such transducers are narrow-banded; that is, they vibrate over a relatively narrow range of frequencies. Since they vibrate with greater amplitude than heavily damped transducers, they are more energetic, producing greater sound beam penetration, but poorer resolution because of increased ringing. On the other hand, heavily damped elements vibrate over a wide range of frequencies and ring for a few cycles, at most, and, in some cases, only one cycle. These broadband transducers have a very flat response with respect to frequency and are optimum in applications where the greatest resolution is desired.

The ability of NDT Systems to tailor the spectral response of an ultrasonic transducer allows the user to select the transducer most suited to the intended use. NDT Systems provides transducers in three general categories of spectral responses. The figures on P6 show typical spectral responses from a nominal frequency 2.25 MHz transducer for each category. Also, see the section on Transducer Documentation and Certification on the following page for more information.



# TRANSDUCER Selection

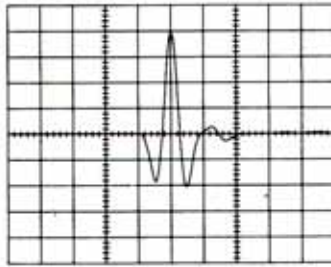

0.50uS/DIV 0.015 V/DIV  
TARGET = .5" SS BALL @ 2"

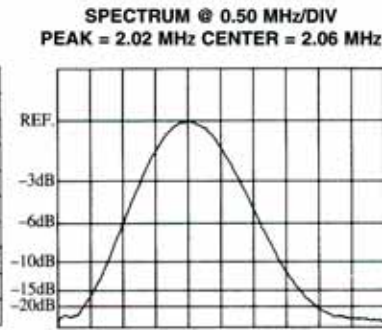

SPECTRUM @ 0.50 MHz/DIV  
PEAK = 2.02 MHz CENTER = 2.06 MHz  
BANDWIDTH @ -6dB = 104.46 %

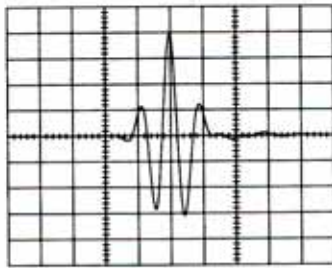

0.50uS/DIV 0.060 V/DIV  
TARGET = .5" S.S. BALL @ 2"

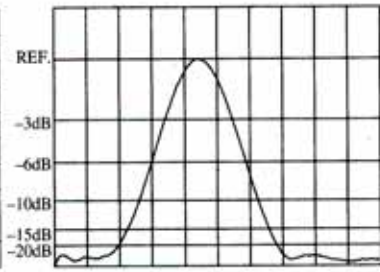

SPECTRUM @ 0.50 MHz/DIV  
PEAK = 2.02 MHz CENTER = 2.21 MHz  
BANDWIDTH @ -6dB = 65.00 %

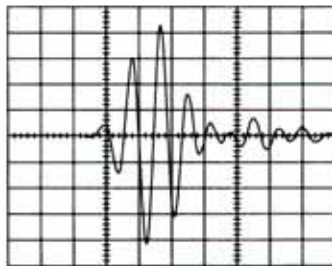

0.50uS/DIV 0.200 V/DIV  
TARGET = .5" S.S. BALL @ 2"

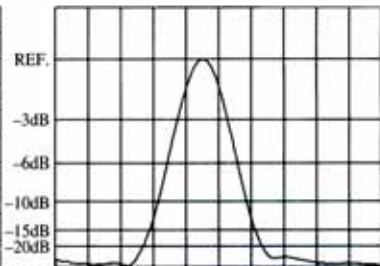

SPECTRUM @ 0.50 MHz/DIV  
PEAK = 2.24 MHz CENTER = 2.25 MHz  
BANDWIDTH @ -6dB = 47.32 %

**High Resolution (HR) Series** transducers are the most heavily damped; hence the most broad banded. While designed to yield maximum near-surface resolution, excellent results are frequently obtained for many flaw detection applications. Even when used with tuned, narrow banded receivers, available in many flaw detectors, the transducer has sufficient frequency components of the tuned frequency to give more than adequate sensitivity and resolution for many flaw detection applications. HR transducers will produce superior results for thickness gaging regardless of the type of receiver/amplifier.

**General Purpose (GP) Series** transducers are usually less damped and, in most cases, tuned and have a bandwidth between the narrow banded and broad banded series. GP transducers offer the best combination of gain, sensitivity, and resolution. The GP Series are generally best for the majority of flaw detection applications.

**High Gain (HG) Series** transducers are less damped, and tuned, and therefore the most narrow banded. This combination produces the most punch in transmission. The very narrow bandwidth, when matched to a narrow banded receiver/amplifier tuned at the same frequency produces high sensitivity (high signal-to-noise). Because of the greater ring-down (or time it takes for the element to stop resonating) with HGs, near surface resolution is sacrificed. Best performance is obtained in applications on highly attenuative, rough surfaced, or relatively thick materials.

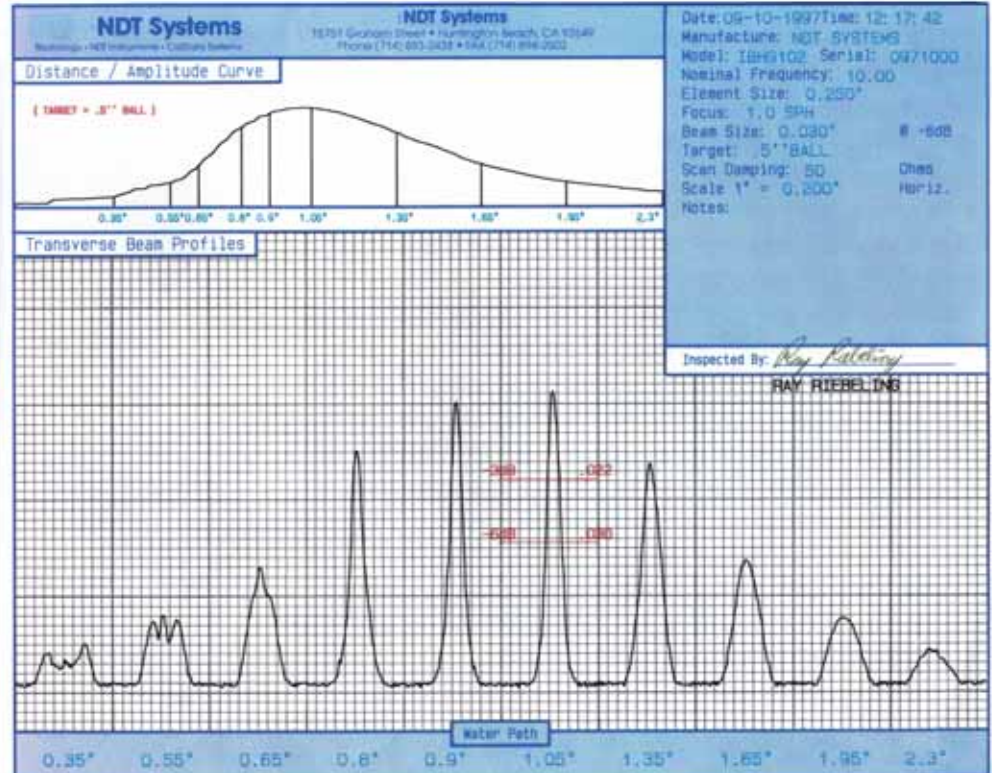
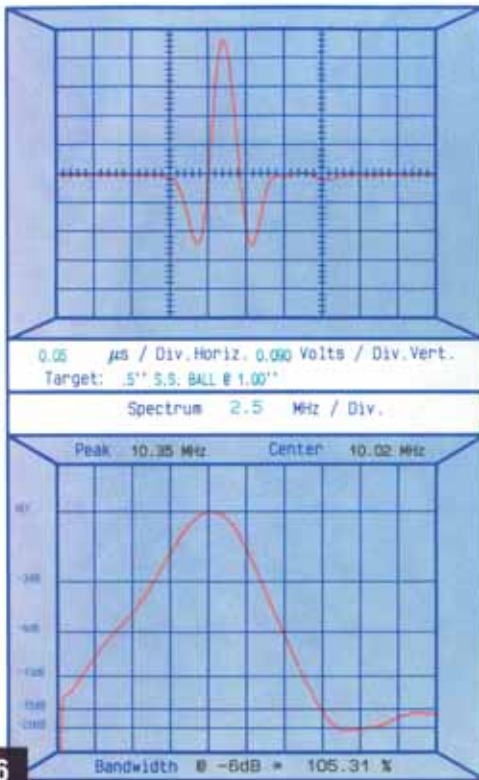

## DOCUMENTATION / CERTIFICATION FORMS

Shown here is the standard Documentation / Certification form as output by NDTSystems Transducer Characterization System. Aside from the information shown in the title block, additional customer requested information can be added.

On the RF waveform, scale information is provided along with a description of the type of target used. The Fast-Fourier Transform (FFT) spectrum is automatically plotted and indicates peak frequency and bandwidth at 6dB.

The distance/amplitude curve is plotted and shows the horizontal position along the beam path where the transverse beam profiles were taken. The beam  $Y_{0+}$  and -6dB distances are clearly indicated, as are the transverse profile distances.

Ten transverse beam profiles are performed at distances defined through software with reference to the distance/amplitude curve, and are performed on the X axis. Profiles at any distance on up to four axes (X, Z, A, B, where A and B are scans at 45° in each direction) can be performed for absolute assurance of beam symmetry at a given distance from the scan target. The beam diameter is also measured at the focal point and the -3dB and -6dB points are displayed.

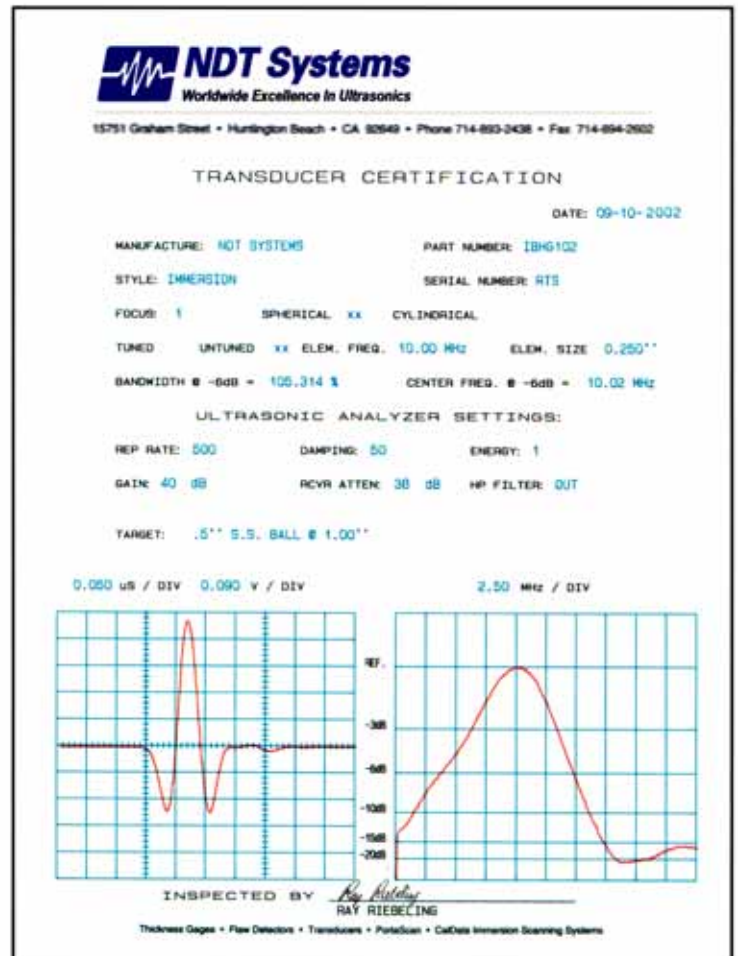

"RTS Certification"

### To Order Transducer Documentation/Certification

If you require transducer documentation at the time of your initial purchase, please specify on your purchase order.

Documentation-RTS  
Documentation-RTSP  
Certification of Conformance-CC

RTS - Documentation can be provided for any transducer, contact or immersion, and includes the Real-Time waveform and FFT Spectrum.

RTSP - Documentation is provided for immersion transducers and includes the Real-Time waveform, the FFT Spectrum, distance/amplitude plot, and Transverse Beam Profiles.

RTSS

Certificate of Conformance-CC is in letter form, and certifies that the transducer meets or exceeds NDT Systems product specifications.

## CONTACT Transducer Selection

Contact Longitudinal Wave Tests are most frequently used on materials or structural forms which are relatively flat. The transducer is generally hand-directed and scanned over one or more exposed surfaces of the test object. In some cases, two transducers are applied on opposite faces of test object, as in through-transmission tests. Application examples for contact transducers include thickness gaging, lamination detection (series dependant) and material sound velocity measurements.

General selection considerations are discussed on page 4. Guidance given in that section along with information presented in the descriptions of each transducer type will help you select the most appropriate transducer for your application.

For longitudinal wave tests where the case of the transducer is in contact with the test specimen, OPTIMA transducers are available in our ALL NEW hardened stainless steel OPTI-GRIP housings.

# CONTACT Transducers

## Fingertip & Standard

**OPTIMA Fingertip Contact Fingertip** transducers are for general purpose use where larger contact transducer won't fit, or where maximum resolution and higher frequencies are needed. With smaller elements and case sizes, these precision fingertip transducers can be used on somewhat smaller contour curvatures than our larger standard models. Best results for precision flaw evaluation will be obtained when used on relatively smooth surfaces.

**Features** - Fingertip models feature low profile, hardened stainless steel cases with NDT Systems' comfortable, positive-control OPTI-GRIP surface. Color-coded labels permit frequency selection at a glance, and have a highly wear-resistant overcoat to protect the label information. OPTIMA contact fingertip transducers are designed for use with all standard flaw detectors.

**OPTIMA Standard Contact** transducers are designed for applications where rough handling is expected, where access is not limited, and/or relatively large element size is needed. These units are commonly used on mill-finished wrought metals, forgings, extrusions and castings, or rough-machined materials.

**Features** - Heavy-duty hardened stainless steel case and wear-resistant alumina wear plate assure long inspection life when used on rough surfaces. These transducers are also easier to handle due to their larger case size. All are tuned with internal matching networks for maximum narrower banded performance giving them extra punchpower, and can be used with any

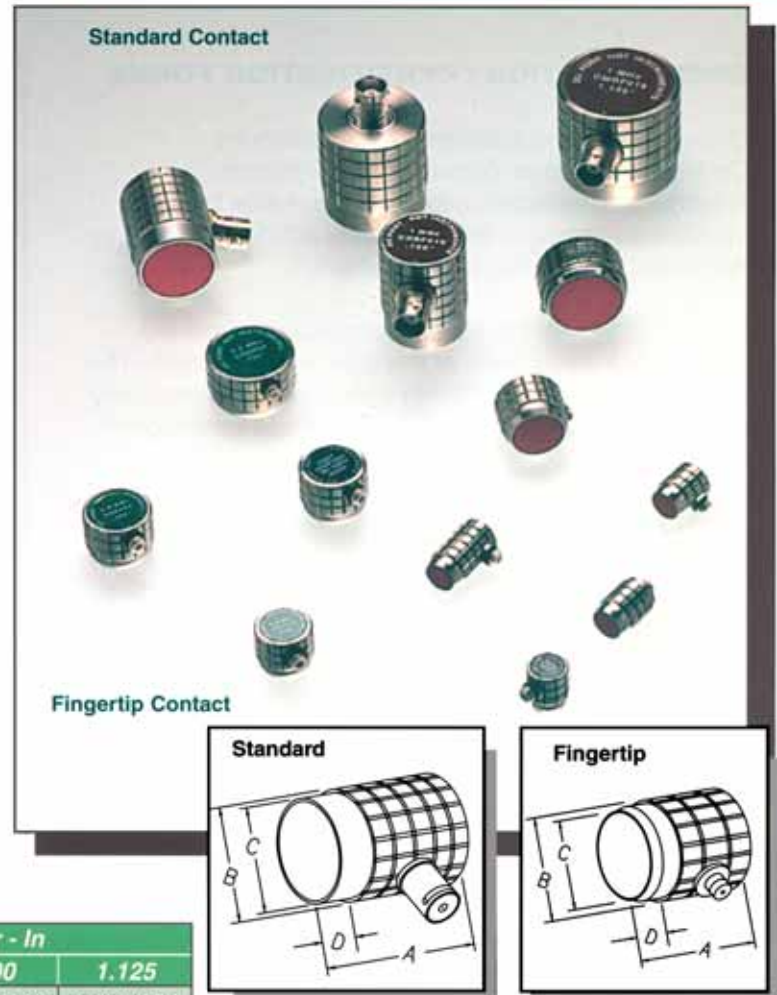

Freq. MHz	Contact Rugged - Element Diameter - In				
	Series	0.50	0.75	1.00	1.125
0.5	General Purpose	CHRF0.54	CHRF0.56	CHRF0.58	CHRF0.59
	Hi Gain	CMRF0.54	CMRF0.56	CMRF0.58	CMRF0.59
1.0	General Purpose	CHRF014	CHRF016	CHRF018	CHRF019
	Hi Gain	CMRF014	CMRF016	CMRF018	CMRF019
2.25	General Purpose	CHRF024	CHRF026	CHRF028	CHRF029
	Hi Gain	CMRF024	CMRF026	CMRF028	CMRF029
3.5	General Purpose	CHRF034	CHRF036	CHRF038	CHRF039
	Hi Gain	CMRF034	CMRF036	CMRF038	CMRF039
5.0	General Purpose	CHRF054	CHRF056	CHRF058	-----
	Hi Gain	CMRF054	CMRF056	CMRF058	-----

Freq. MHz	Fingertip Contact - Element Diameter - In				
	Series	0.250	0.375	0.500	0.750
1.0	General Purpose	CHF012	CHF013	CHF014	CHF016
	Hi Resolution	-----	-----	CHG014	CHG016
2.25	General Purpose	CHF022	CHF023	CHF024	CHF026
	Hi Resolution	CHG022	CHG023	CHG024	CHG026
3.5	General Purpose	CHF032	CHF033	CHF034	CHF036
	Hi Resolution	CHG032	CHG033	CHG034	CHG036
5.0	General Purpose	CHF052	CHF053	CHF054	CHF056
	Hi Resolution	CHG052	CHG053	CHG054	CHG056
7.5	General Purpose	CHF072	CHF073	CHF074	-----
	Hi Resolution	CHG072	CHG073	CHG074	-----
10.0	General Purpose	CHF102	CHF103	CHF104	-----
	Hi Resolution	CHG102	CHG103	CHG104	-----

Element Diameter	Rugged Dimensions - In			
	A	B	C	D
0.5	1.31	0.79	0.74	0.32
0.75	1.31	0.98	0.93	0.32
1.0	1.31	1.25	1.19	0.32

Element Diameter	Fingertip Dimensions - In			
	A	B	C	D
0.25	0.55	0.45	0.36	0.15
0.375	0.56	0.625	0.50	0.16
0.50	0.61	0.75	0.62	0.16
0.75	0.65	1.0	0.87	0.16

**TO ORDER OPTIMA Contact Transducers** use the Model Number from the accompanying table.  
**\*Standard** contact transducers incorporate a side-mounted BNC connector. Top-mounts and UHF connectors are optional and must be designated when ordering.  
**\*Fingertip** models have side-mounted Microdot connectors standard. Top-mounted Microdot connectors are available on some smaller size models.  
**\*For a detailed description of the features** of NDT Systems' GP (General Purpose), HG (High Gain), and HR (High Resolution) series transducers, see page 6.



# CONTACT Transducers

## Delay Line & Protected Element

**OPTIMA Delay Line Contact Transducers** have primary applications in precision thickness gaging and for near-surface, high-resolution flaw detection. Relatively smooth surfaces and fairly thin test objects are generally required for best results.

**Features** of OPTIMA Delay Line Models utilize a plastic stand-off (the delay line) to separate the small, low level echo from the delay-line/test-material interface and the very high amplitude initial pulse-echo at the face of the active element. With a smaller amplitude entry surface echo and higher resolution, more precise distance/thickness measurements can be made than from standard contact style transducers. All OPTIMA Delay Line transducers are highly damped and produce best results when used with broad band receiver settings. Adjustable instrument damping will assure optimum resolution. Delay Line Models are available with both permanent and replaceable delay lines to further enhance the flexibility of this series. Permanent Delay Line Models offer superior handling stability, while Replaceable Delay Lines can be contoured for special applications or replaced when worn.

**OPTIMA Protected Element Transducers** can be fitted with three different types of replaceable protective faces. Used interchangeably, these protective faces extend the use of a single transducer for flaw detection in materials having rough, uneven, abrasive, or hot surfaces. Relatively large element sizes and low-to-midrange frequencies are combined to produce high energy transducers with high penetrating abilities.

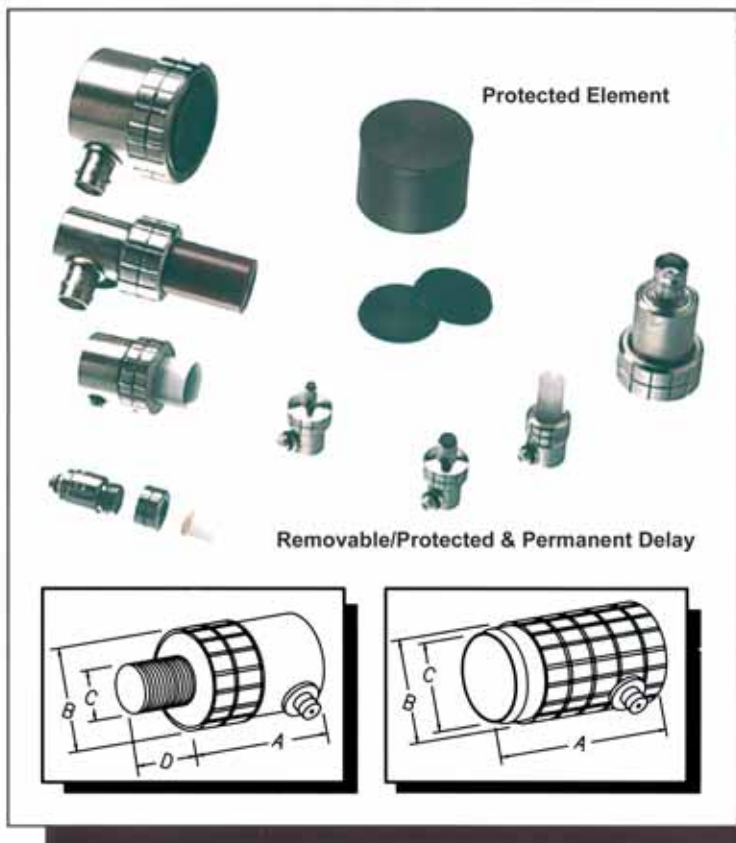

Freq. MHz	Delay Line - Hi Resolution Only - In		
	Style	0.250	0.500
1.0	Permanent Delay	-----	-----
	Replaceable Delay	RDG012	RDG014
2.25	Permanent Delay	-----	PDG024
	Replaceable Delay	RDG022	RDG024
5.0	Permanent Delay	PDG052	PDG054
	Replaceable Delay	RDG052	RDG054
10	Permanent Delay	PDG102	PDG104
	Replaceable Delay	RDG102	RDG104
15	Permanent Delay	PDG152	-----
	Replaceable Delay	PDG152	-----
20	Permanent Delay	PDG202	-----
	Replaceable Delay	RDG202	-----
25	Permanent Delay	PDG252	-----
	Replaceable Delay	RDG252	-----

**Protected Element Models** are fitted with a threaded retaining ring, which retains any of three protective faces in intimate contact with the transducer element. One type of protective face is a somewhat pliable polymeric membrane used to assist coupling to rough or uneven surfaces. The wear-cap face is a short, firm polymeric delay line that can be replaced after use on rough, abrasive surfaces, or where a contoured face is needed. A one-inch long heat-resistant delay line provides protection for the element in high temperature applications (intermittent use up to 600F). All are readily interchangeable.

Element Diameter	Delay Dimensions - In				
	A	B	C	D	
0.25	Permanent Delay	0.80	0.45	0.36	-----
	Replaceable Delay	0.64	0.50	0.30	0.27
0.50	Permanent Delay	0.80	0.75	0.62	-----
	Replaceable Delay	0.87	0.87	0.55	0.38

### Replacement Delays:

RDL - 2

RDL - 4

Freq. MHz	Protected Element Models - Element Diameter - In				
	Series	0.500	0.750	1.000	1.125
0.5	General Purpose	-----	RHF0.56	RHF0.58	RHF0.59
	Hi Gain	-----	RMF0.56	RMF0.58	RMF0.59
1.0	General Purpose	RHF014	RHF016	RHF018	RHF019
	Hi Gain	RMF014	RMF016	RMF018	RMF019
2.25	General Purpose	RHF024	RHF026	RHF028	RHF029
	Hi Gain	RMF024	RMF026	RMF028	RMF029
3.5	General Purpose	RHF034	RHF036	RHF038	-----
	Hi Gain	RMF034	RHF036	RMF038	-----
5.0	General Purpose	RHF054	RHF056	-----	-----
	Hi Gain	RMF054	RMF056	-----	-----

Face Type	Element Diameter - In			
	0.50	0.75	1.00	1.13
Standard Wear Cap	WC4	WC6	WC8	WC9
Elastomeric Membrane	RM4	RM6	RM8	RM9
1 Inch Delay Hi Temp	RD4	RD6	RD8	RD9

Element Diameter	Protected Dimensions - In		
	A	B	C
0.50	0.95	0.70	1.28
0.75	1.18	0.95	1.28
1.00	1.37	1.20	1.28
1.125	1.50	1.33	1.33

TO ORDER OPTIMA Delay Line or Standard Series Transducers use the Model Number from the accompanying table.

- **Delay Line** contact transducers incorporate a side-mounted Microdot connector. Top mounted Microdot connectors are optional and must be designated when ordering.
- **Protected Element** models have side-mounted BNC connectors standard. Top-mounted BNC or UHF connectors are available on some smaller size models.
- All Protected models are supplied with the membrane face. Wear-cap and/or high temperature delay must be ordered separately. (See table for part number.)
- For a detailed description of the features of NDT Systems GP (General Purpose), HG (High Gain), and HR (High Resolution) series transducers, see page 6.

# ANGLE BEAM Transducers

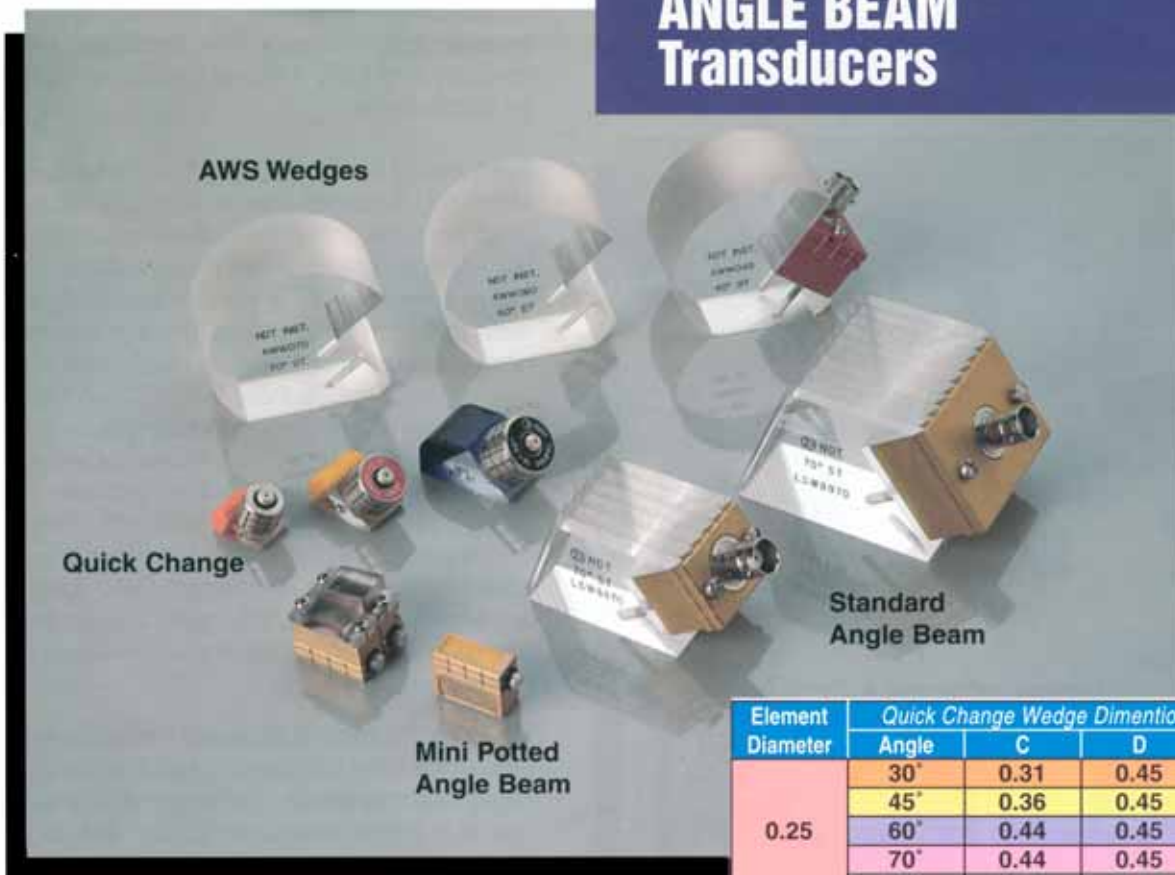

Element Diameter	Quick Change Wedge Dimensions - Inches			
	Angle	C	D	E
0.25	30°	0.31	0.45	0.25
	45°	0.36	0.45	0.39
	60°	0.44	0.45	0.39
	70°	0.44	0.45	0.45
	90°	0.69	0.45	0.51
0.375	30°	0.33	0.55	0.31
	45°	0.38	0.55	0.48
	60°	0.55	0.55	0.54
	70°	0.55	0.55	0.57
	90°	0.84	0.55	0.63
0.50	30°	0.39	0.70	0.39
	45°	0.50	0.70	0.55
	60°	0.57	0.70	0.64
	70°	0.68	0.70	0.69
	90°	1.04	0.70	0.74

**Contact Angle Beam Tests** are a variation of contact testing whereby the sound beam is introduced into the test material at an angle. Plastic wedges of controlled geometry are attached to the transducer active element in order to establish the desired angle. OPTIMA wedges are precision engineered to produce a refracted shear wave within the test object at specific angles, as indicated on the wedge or transducer housing. The refracted beam should be as nearly as possible perpendicular to the plane of expected flaws.

In some cases, the geometry of the test object will dictate the selection of beam angle. With respect to frequency, however, the same general rule applies; that is, select the lowest frequency which provides adequate small-flaw sensitivity. Both noise and attenuation are minimized at lower frequencies.

Probe Dimension	Quick Change - Element Size		
	0.25	0.375	0.50
A	0.45	0.58	0.70
B	0.38	0.38	0.42

**Quick Change Angle Beam Transducers and Wedges** are ideally suited for use where access is limited, on relatively thin materials, or for more precise flaw location and evaluation. The quick change feature is convenient when it is necessary to use different transducer frequencies and /or refracted angle wedges during an inspection or evaluation.

## Quick Change Wedges

These combine our acoustically transmissive sound path material with an attenuating material in the direct path of the internally refracted sound beam. The unique design of these wedges produces a highly noise-free transducer/wedge combination. Because of the compact wedge size, limited contour curvatures are available on special order only.

Frequency MHz	Quick Change Angle Beam Transducers		
	Element Diameter - Inches		
	0.25	0.375	0.50
1.0	-----	-----	TAB014
2.25	TAB022	TAB023	TAB024
3.5	TAB032	TAB033	TAB034
5.0	TAB052	TAB053	TAB054
7.5	TAB072	TAB073	TAB074
10.0	TAB102	TAB103	TAB104

**Quick Change Transducers** feature smaller size circular elements, higher frequencies and a one-quarter wave impedance matching epoxy face. The wear resistant transducer label is also frequency color coded for easy identification. Quick Change models are available with Microdot connectors only.

Refracted Angle	Quick Change Angle Beam Wedges		
	Element Diameter - Inches		
	0.25	0.375	0.50
30°	TAW230	TAW330	TAW430
45°	TAW245	TAW345	TAW445
60°	TAW260	TAW360	TAW460
70°	TAW270	TAW370	TAW470
90°	TAW290	TAW390	TAW490

Element Size	Mini - Dimention - In		
	A	B	C
0.19 x 0.19	0.75	0.34	0.62
0.25 x 0.25	0.75	0.34	0.62
0.38 x 0.38	0.95	0.50	0.82
0.50 x 0.50	1.25	0.62	0.92

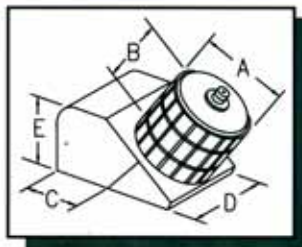

Quick Change

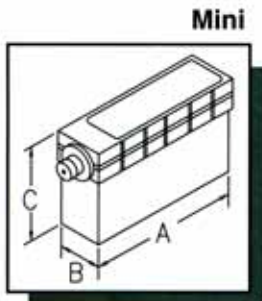

Mini

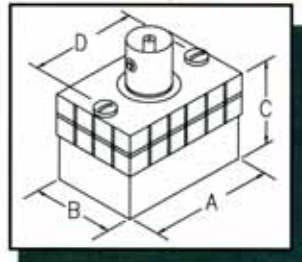

Standard

Frequency MHz	Refracted Angle	Mini Potted Angle Beam Element Dimentions - In			
		0.19 x 0.19	0.25 x 0.25	0.38 x 0.38	0.50 x 0.50
2.25	45°	MPA0214	MPA0224	MPA0234	MPA0244
	60°	MPA0216	MPA0226	MPA0236	MPA0246
	70°	MPA0217	MPA0227	MPA0237	MPA0247
	90°	MPA0219	MPA0229	MPA0239	MPA0249
5.0	45°	MPA0514	MPA0524	MPA0534	MPA0544
	60°	MPA0516	MPA0526	MPA0536	MPA0546
	70°	MPA0517	MPA0527	MPA0537	MPA0547
	90°	MPA0519	MPA0529	MPA0539	MPA0549
10.0	45°	MPA1014	MPA1024	MPA1034	MPA1044
	60°	MPA1016	MPA1026	MPA1036	MPA1046
	70°	MPA1017	MPA1027	MPA1037	MPA1047
	90°	MPA1019	MPA1029	MPA1039	MPA1049

**Standard & AWS Transducer Features** - Standard and AWS Angle Beam transducers feature all-metal cases for maximum durability, epoxy faces for optimum acoustic impedance matching with wedges, frequency color-coded labels, and captive screws for ease of interchanging wedges. Damping is designed to produce an optimum combination of high gain, sensitivity, resolution and signal-to-noise when used with standard pulse-echo ultrasonic flaw detectors. Standard transducer connectors are BNC; UHF is optional and must be specified

**Standard & AWS Wedges** - Acrylic wedges are available in two configurations, each designed to greatly reduce internal reflection noise. Serrated wedges contain integrally machined grooves that reflect and scatter internal reflections; the "snail" wedge, available only for the AWS Series, continuously reflect and reflect the internal sound beam to, in effect, "trap" unwanted noise, providing a better signal-to-noise ratio.

**Mini Potted Angle Beam Transducers** are very small and permit testing in highly confined areas, on small parts, and contoured surfaces and simplify access between closely-spaced fasteners. Having a narrow, restricted sound beam also facilitates more precise evaluation and mapping of flaws.

**Mini Angle Beam Transducer Features** an element and wedge which are permanently mounted in a compact aluminum case with the exclusive OPTI-GRIP surface for ease of handling. Internal serrations and bi-material wedge dampening reduce noise. The wedge material extends slightly beyond the case surfaces, thus permitting a small amount of wedged surface wear before replacement is necessary. Side-mounted connectors are standard. If top-mounted connector is desired, add -TC to Model Number.

Refracted Angle	Standard Series Wedges (Fits Element Dimention)			
	0.50 x 0.50	0.50 x 1.00	0.75 x 1.00	1.00 x 1.00
30°	LSW4430	LSW4830	LSW6830	LSW8830
45°	LSW4445	LSW4845	LSW6845	LSW8845
60°	LSW4460	LSW4860	LSW6860	LSW8860
70°	LSW4470	LSW4870	LSW6870	LSW8870
90°	LSW4490	LSW4890	LSW6890	LSW8890

Element Frequency	Element Size - Inches (Standard Series)			
	0.50 x 0.50	0.50 x 1.00	0.75 x 1.00	1.00 x 1.00
1.0	LSA0144	LSA0148	LSA0168	LSA0188
2.25	LSA0244	LSA0248	LSA0268	LSA0288
3.5	LSA0344	LSA0348	LSA0368	LSA0388
5.0	LSA0544	LSA0548	LSA0568	LSA0588

Probe Dimentions	Standard And AWS Series Dimentions				AWS Type All Sizes
	Element Size - Inches (Standard Series)				
A	0.50 x 0.50	0.50 x 1.00	0.75 x 1.00	1.00 x 1.00	1.25
B	0.75	0.75	1.00	1.25	0.85
C	0.75	0.75	0.75	0.75	0.75
D	0.81	1.31	1.31	1.38	1.00

Element Frequency	Element Size - Inches AWS Type		
	0.625 x 0.625	0.625 x 0.75	0.75 x 0.75
2.25	AWS0255	AWS0256	AWS0256

Refracted Angle	AWS Wedges
45°	AWW045
60°	AWW060
70°	AWW070

TO ORDER Standard and AWS Transducers and Wedges, select the model number from the accompanying tables. Also note: For wedges, refracted beam angles are standard for steel or aluminum. Be sure to specify which! For steel, add -S to Model Number. For aluminum, add -A to Model Number. If unspecified, angles for steel will be supplied. For other test materials, specify the material or submit a sample. Wedges for curved surfaces, metals other than steel or aluminum, elevated temperatures, and other custom designs are manufactured to order and require additional delivery time. Please inquire for price and delivery. 6-32 screw holes are provided standard series Angle Beam Wedges. 4-40 threads can be provided on special order. 4-40 screw holes are provided for AWS series transducers only.

# GENERAL PURPOSE Dual Element

## Finger Tip Series

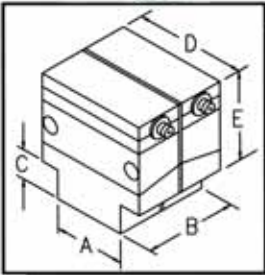

## Rectangular Series

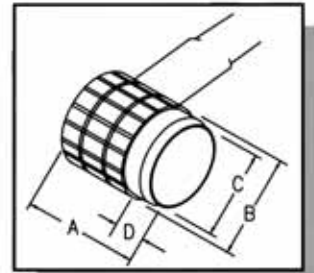

Dual Element Potted Fingertip			
Freq. MHz	Element Size - in		
	0.25"	0.375"	0.50"
1	-----	-----	DVF014
2.25	DVF022	DVF023	DVF024
3.5	DVF032	DVF033	DVF034
5.0	DVF052	DVF053	DVF054
7.5	DVF072	DVF073	DVF074
10.0	DVF102	DVF103	-----

Element Size	Element Dimensions - in			
	A	B	C	D
.250 Dia	0.55	0.45	0.36	0.15
.375 Dia	0.56	0.625	0.50	0.16
.500 Dia	0.61	0.75	0.62	0.16

Element Size	Dual Element Dimensions - in				
	A	B	C	D	E
.50 X .50	0.52	0.70	0.20	0.80	0.83
.50 X 1.00	1.05	0.70	0.25	1.50	1.04

Dual Element Rectangular		
Freq. MHz	Element Size - in	
	0.50 x 0.50"	0.50 x 1.00"
1	DXR0144	DXR0148
2.25	DXR0244	DXR0248
3.5	DXR0344	DXR0348
5.0	DXR0544	DXR0548

**Dual Element Transducers** - These transducers produce improved near-surface resolution when compared with normal single element contact transducers. Used on instruments having isolated pulser/receiver connections (through-transmission mode on many instruments), each of the elements functions independently, one as a transmitter, the other as a receiver. Having a remarkable combination of sensitivity, penetration and resolution, dual element transducers are used in precision thickness gaging applications, and for detection of corrosion, erosion, pits and small internal laminar or elongated flaws.

Replacement Delay Lines		
Delay Type	Delay Size - in	
	0.50 x 0.50"	0.50 x 1.00"
Acrylic	DX44	DX48
Hi Temp	DXH44	DXH48

**Cylindrical Fingertip Models** - Small cylindrical fingertip sizes are provided in hardened Stainless Steel cases and are ideal for areas where access is restricted or when maximum sensitivity and highest resolution are desired. Intermittent operation on hot surfaces up to 400°F is possible using a 15% duty cycle. The cable is permanently side-mounted with two BNC connectors for ultrasonic instrument hook-up.

**Rectangular Duals** are recommended for more rugged applications or applications requiring greater coverage. These models have replaceable delay lines and cross-talk barriers for use in high-wear applications or where shaped delay lines are needed. The standard delay line on rectangular duals is acrylic. A high temperature delay (intermittent operation to 400°F) option is also offered. Side-mounted Microdot connectors are standard.

# NOVA SERIES Dual Element - Probes

Nova TG110DL



Features include:  
 50" Range  
 Time Encoded 'B' Scan  
 50,000 Point Data Logger  
 Min, Max Cap & Alarms  
 AutoProbe Recognition  
 PC Data Transfer Package

**NDT Systems' Nova transducers** listed on this page perform superbly on our older Nova models as well as the current models. Although some older Nova transducer model numbers have changed, the descriptions given here will readily enable you to match earlier models with the new ones. Please choose the appropriate model transducer for the appropriate model thickness gage.

	Model	Range	Freq	Dia	Dia @ tip	Height	Temp		Holder
DV-506	6 100D	0.040-9.999	5.0	0.375	0.56	1.30	600°F	LMD-1	BH-1
DV-507	6 100D	0.060-9.999	5.0	0.375	0.56	1.30	600°F	LMD-1	BH-1
DF-505	4 100D	.040-2.000	5.0	0.300	0.55	0.45	400°F	Side - Int	N/A
DF-505TM	2 100D	.040-2.000	5.0	0.300	0.55	0.45	400°F	Top - Int	N/A
DF-502	3 100D	.060-2.000	5.0	0.220	0.28	0.75	150°F	Side - Int	N/A
DF-502TM	1 100D	.060-2.000	5.0	0.220	0.28	0.75	150°F	Top - Int	N/A
DV-208	7 100D	0.200-9.999	2.0	0.600	0.90	1.50	600°F	LMD-1	BH-2
DQ506	9 100D	0.200-9.999	5.0	0.375	0.60	3.40	1000°F	LMD-1	BH-3
TG-506	6 TG110	0.040-9.999	5.0	0.375	0.56	1.30	450°F	LMD-1	BH-1
TG-556	6 TG110	0.040-9.999	5.0	0.375	0.56	1.30	600°F	LMD-1	BH-1
TG-560P	6 TG110	0.040-9.999*	5.0	0.375	0.90	1.50	450°F	LMD-1	BH-1
TG-790	8 TG110	0.040-9.999	5.0	0.280	0.43	2.50	900°F	LMD-1	N/A
TG-505	4 TG110	0.040-9.999	5.0	0.375	0.60	3.40	450°F	Side - Int	N/A
TG-505TM	2 TG110	0.040-9.999	5.0	0.375	0.56	1.30	450°F	Side - Int	N/A
TG-208	7 TG110	0.200-9.999	2.0	0.375	0.56	0.80	450°F	LMD-1	BH-2
TQ-506	9 TG110	0.200-9.999	2.0	0.600	0.90	1.50	1000°F	LMD-1	BH-3
TG-502	3 TG110	0.060-1.000	10.0	0.280	0.38	0.80	450°F	Side - Int	N/A
TG-502TM	TG110	0.060-1.000	5.0	0.375	0.60	3.40	450°F	Side - Int	N/A

\* 0.110 - 3" in Through Paint Mode

Temperatures indicated are for intermittent applications only. The temperature of the transducer case should not exceed 200 degrees F where no temperature is indicated.

BH style probe holders are made of aluminum with a flared skirt and recessed set screw for attachment to the transducer.

## Immersion Transducer Selection

Ultrasonic soundwaves travel at a much lower velocity in water than in most engineering materials of interest. In aluminum and steel alloys, for instance, the longitudinal wave velocity is roughly four times greater than in water; in common plastics and composites, two to three times greater. Because of this velocity difference, the length of the near-field is proportionately greater in water. Beam divergence (beam spread) is also proportionately greater, causing significant energy dispersion over modest water path lengths between the transducer and test object. While, on the one hand, immersion or squirter-type water coupling the soundbeam from transducer to test object is relatively efficient, near-field and beam spread effects must be considered for optimum testing results.

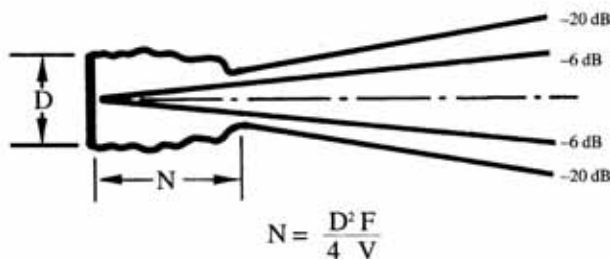

Fortunately, the mere fact that the face of the transducer is in the water permits the soundbeam to be easily focused. Focusing has the dual effect of modifying near-field effects and concentrating the beam energy. Focusing also can enhance soundbeam coupling into curved test object surfaces.

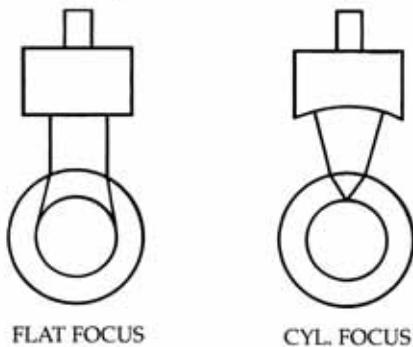

Focusing the ultrasonic soundbeam is accomplished in a manner similar to the way light beams are focused with lenses. An epoxy "lens" bonded to the flat face of a transducer element produces the desired result. Several different lens types have been developed; however, those most commonly used are spherically or cylindrically concave.

In water, with a spherical lens, the soundbeam is focused toward a point. The distance between the lens surface and the focal point depends upon the spherical radius of the lens, as well as the size and frequency of the element. Small radii produce shorter focal lengths.

The same is true of cylindrical lenses; the major difference is that the soundbeam is focused toward a line shape. In neither case can the soundbeam be focused precisely to a point or a line.

At or near the theoretical focus, the soundbeam maintains shape within a short zone before it again diverges and rapidly spreads out and disperses. Spherically focused beams are column-shaped for a short distance near focus, having a circular cross-section, while cylindrically focused beams have a rectangular cross-section.

At water path distances less than the theoretical focus, if the focused soundbeam enters the test material (having greater sound velocity), the soundbeam converges even-

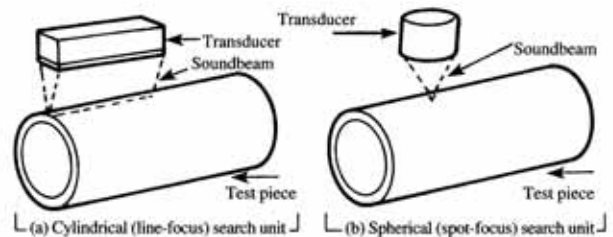

more rapidly than in water. The combined effect of having a convergent beam in water, converging even more so in the test object, concentrates the available energy from the transducer into a highly confined region of the area under test.

The sensitivity of the resultant focused soundbeam and its ability to respond to very small discontinuities is therefore much greater than with a divergent soundbeam. However, the volume of material being instantaneously "illuminated" by a focused beam is substantially smaller than that of a divergent beam. If a large volume of material must be tested, in order to provide complete coverage, the distance between scans (the scan interval) must be very small if focusing is used.

Aside from concentrating the beam energy for test applications requiring small-flaw detection sensitivity, focusing has the added effect of "smoothing" soundwave pressure variations within the near-field. In fact, focal lengths much larger than approximately three-quarters the distance between the theoretical boundary between the near- and far-field have little focusing effect. Longer focal lengths only serve to reduce the effective energy within the soundbeam as compared with an unfocused, flat-faced transducer. There is also a practical minimum focal length that is effective. This distance varies as a combined function of frequency and element size. Both maximum and minimum practical limits of focal length are presented in the table to the right.

The maximum focal length tabulated is approximately three-quarters of the distance to the terminus of the near-field. This theoretical boundary is called  $Y_+$ , and is based on the sound pressure produced from a theoretical, single-frequency transducer. Even the most narrowbanded transducers manufactured by NDT Systems radiate soundfields having a range of frequencies. The lower frequency components tend to reduce the effective  $Y_+$  distance; hence, the 0.75  $Y_+$  maximum. This effect is even more pronounced with broadband transducers such as NDT Systems' High Resolution (HR) Series.

The practical maximum focal length of highly damped transducers tends to be closer to 0.6  $Y_+$ . The minimum practical focal lengths listed in the table to the left can be used to specify transducers useful only for very near-surface applications. Their depth of field is so limited that the soundfield diverges very rapidly beyond the focal point. As a rule of thumb, focal lengths midway between minimum and maximum produce an effective compromise between sensitivity and depth of field.

MHz	Dia - in	Yo+	(-6dB@Yo)	Min	Max	Percentage of Yo+ Shown (in)		
						25%	50%	75%
0.5	0.5	0.53	0.126	N/P	N/P	N/P	N/P	N/P
	0.75	1.2	0.191	N/P	1.00	N/P	0.095	0.143
	1.00	2.14	0.255	1.00	1.50	0.064	0.128	0.191
	1.125	2.74	0.290	1.50	2.00	0.073	0.145	0.218
1.0	0.125	0.06	0.029	N/P	N/P	N/P	N/P	N/P
	0.25	0.27	0.064	N/P	N/P	N/P	N/P	N/P
	0.375	0.6	0.095	N/P	0.50	0.024	0.048	0.072
	0.5	1.07	0.128	N/P	0.75	N/P	N/P	0.096
	0.75	2.41	0.192	1.00	1.75	0.048	0.096	0.144
	1.00	4.28	0.255	1.50	3.00	0.064	0.128	0.191
2.25	1.125	5.41	0.287	1.50	4.00	0.072	0.143	0.215
	0.125	0.15	0.032	N/P	N/P	N/P	N/P	N/P
	0.25	0.6	0.064	N/P	0.50	N/P	N/P	0.048
	0.375	1.35	0.095	N/P	1.00	N/P	N/P	0.072
	0.5	2.4	0.127	1.00	1.75	0.032	0.064	0.095
	0.75	5.41	0.191	1.50	4.00	0.048	0.096	0.143
3.5	1.00	9.63	0.255	2.00	7.00	0.064	0.128	0.191
	1.125	12.19	0.287	2.00	9.00	0.072	0.144	0.215
	0.125	0.23	0.031	N/P	N/P	N/P	N/P	N/P
	0.25	0.94	0.064	N/P	0.75	N/P	N/P	0.048
	0.375	2.11	0.096	0.75	1.50	0.024	0.048	0.072
	0.5	3.75	0.128	1.00	3.00	0.032	0.064	0.096
5.0	0.75	8.43	0.191	1.50	6.00	0.048	0.096	0.144
	1.00	14.98	0.255	2.00	11.00	0.064	0.128	0.191
	1.125	18.96	0.287	4.00	14.00	0.072	0.144	0.215
	0.125	0.33	0.031	N/P	N/P	N/P	N/P	N/P
	0.25	1.34	0.064	0.50	1.00	0.016	0.032	0.048
	0.375	3.01	0.096	0.75	2.00	0.024	0.048	0.072
7.5	0.50	5.35	0.128	1.00	4.00	0.032	0.064	0.096
	0.75	12.04	0.191	1.50	9.00	0.048	0.096	0.144
	1.00	21.4	0.255	4.00	16.00	0.064	0.128	0.191
	0.125	0.5	0.032	N/P	N/P	N/P	N/P	N/P
	0.25	2.01	0.064	0.50	1.50	0.016	0.032	0.048
	0.375	4.51	0.096	0.75	3.50	0.024	0.048	0.072
10	0.50	8.03	0.128	1.50	6.00	0.032	0.064	0.096
	0.75	18.06	0.191	3.50	13.00	0.048	0.096	0.144
	0.125	0.67	0.032	N/P	0.50	N/P	N/P	N/P
	0.25	2.68	0.064	0.50	2.00	0.016	0.032	0.048
	0.375	6.02	0.096	0.75	4.50	0.024	0.048	0.072
	0.50	10.70	0.128	1.00	8.00	0.032	0.064	0.096
15	0.75	24.08	0.191	1.50	10.00	0.048	0.096	0.144
	0.125	1.00	0.032	0.50	0.75	0.008	0.016	0.024
	0.25	4.01	0.064	0.50	3.00	0.016	0.032	0.048
	0.375	9.02	0.096	0.75	7.00	0.024	0.048	0.072
	0.50	16.05	0.128	1.00	12.00	0.032	0.064	0.096
	0.75	24.08	0.191	1.50	10.00	0.048	0.096	0.144
20	0.125	1.34	0.032	0.50	1.00	0.008	0.016	0.024
	0.25	5.35	0.064	0.75	4.00	0.016	0.032	0.048
	0.375	12.03	0.096	1.00	9.00	0.024	0.048	0.072
	0.125	1.67	0.032	0.50	1.25	0.008	0.016	0.024
	0.25	6.99	0.067	0.50	5.00	0.017	0.033	0.050



## A Style Pencil Case Models

Pencil Case Immersion Transducers are designed for use where access is limited, or when small, relatively high frequency, active elements are needed. Exacting manufacturing and quality control methods assure the most uniform characteristics from unit-to-unit.

## B Style Slim Case Models

Slim Case Immersion transducers are offered with a wide range of element sizes and frequencies. Most high-specification and other precision testing requirements are easily satisfied with these versatile transducers.

## C and F Style Models

'C' and 'F' Style Immersion Transducers are designed for exceptional performance in applications requiring higher beam energy and relatively lower frequencies. They are often used to examine products with mill-finish surfaces, such as pipe, forgings, billets, plates, shapes and extrusions. Larger diameter elements permit greater scan indexes for faster coverage of large test objects.

A Style Pencil Case

B Style Slim Case

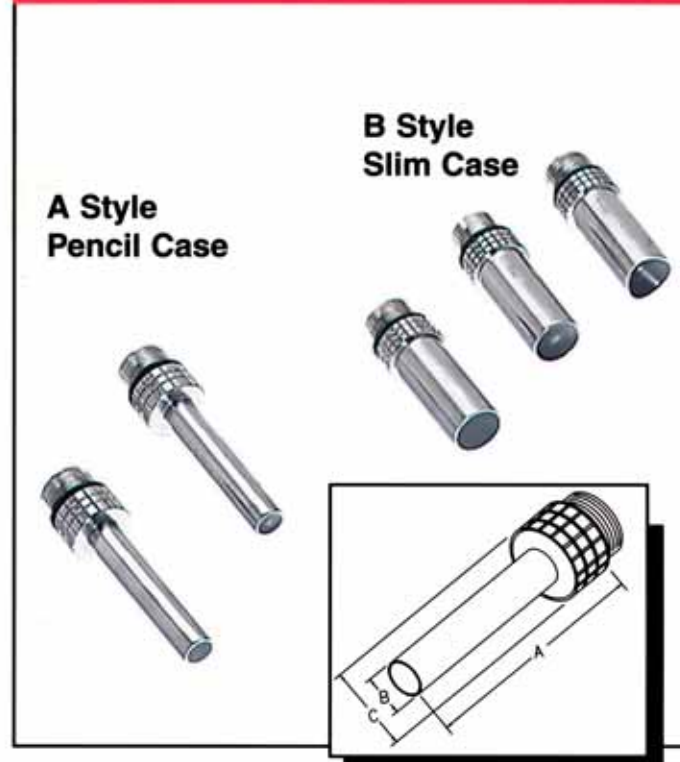

Freq. MHz	Series	A-Style		B-Style			C-Style	
		0.125"	0.250"	0.250"	0.375"	0.500"	0.500"	0.750"
0.50	General Purpose	-----	-----	-----	-----	-----	ICHF0.54	ICHF0.56
	Hi Resolution	-----	-----	-----	-----	-----	-----	-----
	Hi Gain	-----	-----	-----	IBMF0.53	IBMF0.54	ICMF0.54	ICMF0.56
1.0	General Purpose	-----	IAHF012	IBHF012	IBHF013	IBHF014	ICHF014	ICHF016
	Hi Resolution	IAHG011	IAHG012	IBHG012	IBHG013	IBHG014	ICHG014	ICHG016
	Hi Gain	IAMF011	IAMF012	IBMF012	IBMF013	IBMF014	ICMF014	ICMF016
2.25	General Purpose	-----	IAHF022	IBHF022	IBHF023	IBHF024	ICHF024	ICHF026
	Hi Resolution	IAHG021	IAHG022	IBHG022	IBHG023	IBHG024	ICHG024	ICHG026
	Hi Gain	IAMF021	IAMF022	IBMF022	IBMF023	IBMF024	ICMF024	ICMF026
3.5	General Purpose	IAHF031	IAHF032	IBHF032	IBHF033	IBHF034	ICHF034	ICHF036
	Hi Resolution	IAHG031	IAHG032	IBHG032	IBHG033	IBHG034	-----	-----
	Hi Gain	IAMF031	IAMF032	IBMF032	IBMF033	IBMF034	ICMF034	ICMF036
5.0	General Purpose	IAHF051	IAHF052	IBHF052	IBHF053	IBHF054	ICHF054	ICHF056
	Hi Resolution	IAHG051	IAHG052	IBHG052	IBHG053	IBHG054	ICHG054	ICHG056
	Hi Gain	IAMF051	IAMF052	IBMF052	IBMF053	IBMF054	ICMF054	ICMF056
7.5	General Purpose	IAHF071	IAHF072	IBHF072	IBHF073	IBHF074	ICHF074	ICHF076
	Hi Resolution	IAHG071	IAHG072	IBHG072	IBHG073	IBHG074	ICHG074	ICHG076
	Hi Gain	IAMF071	IAMF072	IBMF072	IBMF073	IBMF074	ICMF074	ICMF076
10	General Purpose	IAHF101	IAHF102	IBHF102	IBHF103	IBHF104	ICHF104	-----
	Hi Resolution	IAHG101	IAHG102	IBHG102	IBHG103	IBHG104	ICHG104	-----
	Hi Gain	IAMF101	IAMF102	IBMF102	IBMF103	IBMF104	-----	-----
15	General Purpose	IAHF151	IAHF152	IBHF152	IBHF153	IBHF154	-----	-----
	Hi Resolution	IAHG151	IAHG152	IBHG152	IBHG153	-----	-----	-----
	Hi Gain	-----	-----	IBMF152	-----	-----	-----	-----
20	General Purpose	IAHF201	IAHF202	IBHF202	-----	-----	-----	-----
	Hi Resolution	IAHG201	IAHG202	IBHG202	IBHG203	-----	-----	-----
	Hi Gain	-----	-----	-----	-----	-----	-----	-----
25	General Purpose	IAHF251	IAHF252	IBHF252	-----	-----	-----	-----
	Hi Resolution	IAHG251	IAHG252	IBHG252	-----	-----	-----	-----
	Hi Gain	-----	-----	-----	-----	-----	-----	-----

**Features of All Immersion Transducers** - Stainless Steel cases are incorporated on all standard immersion transducers. An integral UHF connector and OPTI-GRIP flange surface provide for easy attachment and removal from search tubes. The sealed epoxy face prevents water intrusion and provides ideal impedance matching to water. For utmost sensitivity and gain, flat faced models are precision finished to quarter-wavelength thickness which further enhances transmission of the sound beam.

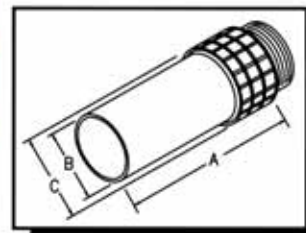

TO ORDER OPTIMA Immersion Transducers, use the Model Number from the accompanying table. For a detailed description of the features of NDT Systems' GP (General Purpose), HG (High Gain), and HR (High Resolution) transducers, see page 6. Also note: Spherical or cylindrical focusing to customer-specified focal lengths (in water) is available. Always Be Sure To Specify Focus, if any. No focus (flat face) will be provided if no focus is defined. See chart on page 15 for practical focal limits. Custom length tip extensions are available on request. Right angle element mounting is offered optionally. Other angles can also be provided. Available with top-mounted UHF connector only. Complete standard or custom documentation/certification is available. See page 6 & 7 for details.



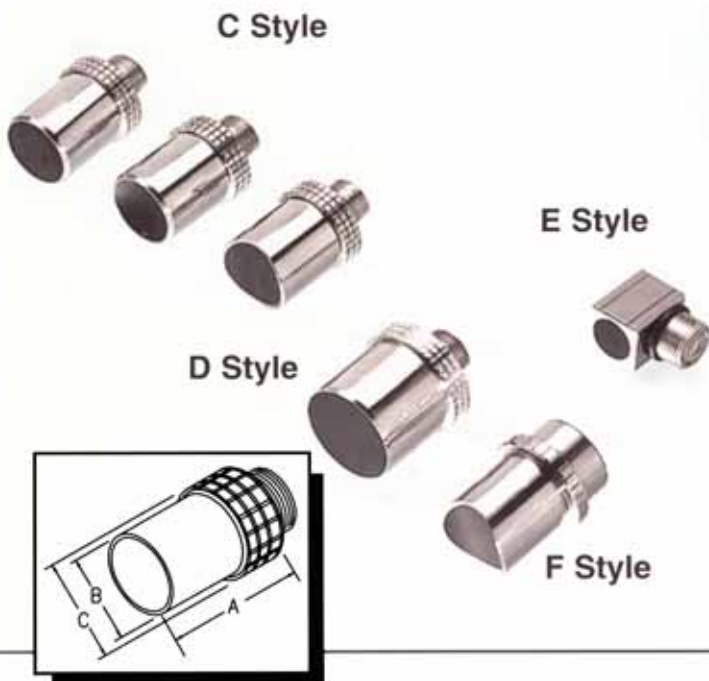

### D Style Models

D Style Immersion Transducers combine large elements with low frequencies for optimum results on rough-surfaced and/or attenuative test objects. Larger element sizes reduce beam-spreading and allow wider scan intervals. This series is often selected for testing inherently "noisy" materials. The right combination of element size and frequency can reduce noise reflections from coarse grain structure, or acceptable, small or scattered inclusions. In such cases, larger rejectable flaws can be more easily detected.

### E Style Models

E-Style Immersion Transducers are the perfect choice for direct right angle beam applications, including through-transmission, inside diameters, bore holes and other limited access conditions. Available in a wide range of frequencies and sizes.

All immersion series transducers are available in three different spectral responses to accommodate a wide range of applications. Optional right angle element mounting or slip-on angle reflectors also increase flexibility. Spherical or cylindrical focusing provides extremely tight access limitations. Focusing can increase sensitivity for the detection of small discontinuities, and enhance near-surface resolution and flaw depth discrimination.

D - Style		F - Style		E - Style			Series	Freq. MHz
1.00"	1.125"	0.500"	0.750"	0.250"	0.375"	0.500"		
IDHF0.58	IDHF0.59	IFHF0.54	IFHF0.56	-----	-----	-----	General Purpose	0.50
-----	-----	-----	-----	-----	-----	-----	Hi Resolution	
IDMF0.58	IDMF0.59	IFMF0.54	IFMF0.56	-----	IEMF0.53	IEMF0.54	Hi Gain	1.0
IDHF0.18	IDHF0.19	IFHF0.14	IFHF0.16	IEHF0.12	IEHF0.13	IEHF0.14	General Purpose	
IDHG0.18	IDHG0.19	IFHG0.14	IFG0.16	IEHG0.12	IEHG0.13	IEHG0.14	Hi Resolution	2.25
IDMF0.18	IDMF0.19	IFMF0.14	IFMF0.16	IEMF0.12	IEMF0.13	IEMF0.14	Hi Gain	
IDHF0.28	IDHF0.29	IFHF0.24	IFHF0.26	IEHF0.22	IEHF0.23	IEHF0.24	General Purpose	3.5
IDHG0.28	IDHG0.29	IFHG0.24	IFHG0.26	IEHG0.22	IEHG0.23	IEHG0.24	Hi Resolution	
IDMF0.28	IDMF0.29	IFMF0.24	IFMF0.26	IEMF0.22	IEMF0.23	IEMF0.24	Hi Gain	5.0
IDHF0.38	-----	IFHF0.34	IFHF0.36	IEHF0.32	IEHF0.33	IEHF0.34	General Purpose	
IDHG0.38	-----	IFHG0.34	IFHG0.36	IEHG0.32	IEHG0.33	IEHG0.34	Hi Resolution	7.5
IDMF0.38	IDMF0.39	IFMF0.34	IFMF0.36	IEMF0.32	IEMF0.33	IEMF0.34	Hi Gain	
IDHF0.58	-----	IFHF0.54	IFHF0.56	IEHF0.52	IEHF0.53	IEHF0.54	General Purpose	10
IDHG0.58	-----	IFHG0.54	IFHG0.56	IEHG0.52	IEHG0.53	IEHG0.54	Hi Resolution	
IDMF0.58	-----	IFMF0.54	IFMF0.56	IEMF0.52	IEMF0.53	IEMF0.54	Hi Gain	15
IFHF0.74	IFHF0.76	IFHF0.74	IFHF0.76	IEHF0.72	IEHF0.73	IEHF0.74	General Purpose	
IFHF0.74	IFHF0.76	IFHF0.74	IFHF0.76	IEHG0.72	IEHG0.73	IEHG0.74	Hi Resolution	20
IFMF0.74	IFMF0.76	IFMF0.74	IFMF0.76	IEMF0.72	IEMF0.73	IEMF0.74	Hi Gain	
IFHF104	-----	IFHF104	-----	IEHF102	IEHF103	IEHF104	General Purpose	25
IFHG104	-----	IFHG104	-----	IEHG102	IEHG103	IEHG104	Hi Resolution	
-----	-----	-----	-----	IEMF102	IEMF103	-----	Hi Gain	20
IEHF152	IEHF153	-----	-----	IEHF152	IEHF153	-----	General Purpose	
IEHG152	IEGH153	-----	-----	IEHG152	IEGH153	-----	Hi Resolution	25
IEMF152	-----	-----	-----	IEMF152	-----	-----	Hi Gain	
IEHF202	-----	-----	-----	IEHF202	-----	-----	General Purpose	20
IEHG202	-----	-----	-----	IEHG202	-----	-----	Hi Resolution	
-----	-----	-----	-----	-----	-----	-----	Hi Gain	25
IEHF252	-----	-----	-----	IEHF252	-----	-----	General Purpose	
IEHG252	-----	-----	-----	IEHG252	-----	-----	Hi Resolution	20
-----	-----	-----	-----	-----	-----	-----	Hi Gain	

Immersion Style	Immersion Case Dimensions		
	A	B	C
A	2.500	0.375	0.750
B	1.750	0.625	0.750
C & F	1.375	1.000	1.125
D	1.375	1.250	1.375
E	0.750	0.620	0.620

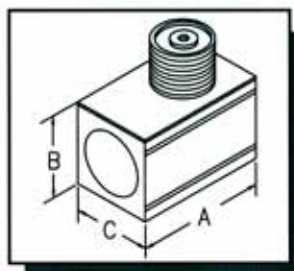

# NOVA Transducers



## Nova and NovaScope Transducers

For many years, NDT Systems has manufactured the highest quality precision ultrasonic thickness gages. The NOVA line continues to provide unmatched performance in a wide range of demanding industry applications.



These transducers exhibit extremely good, high frequency, broad banded responses which are particularly suited to precision thickness gaging. The echo envelope normally exhibits 1-1 1/2 cycles. Designed for use primarily on the NDT Systems Nova series of instrumentation, these transducers will also offer superior response when used with many of today's higher performance pulser-receiver combinations.

## NOVA Precision Transducers

MODEL	APPLICATION	THICKNESS RANGE	ELEMENT		CASE SIZE-INCHES	
			FREQ. MHz.	DIA. IN.	DIA.	HEIGHT
10 C11	General Purpose	0.062-19.999"	5	0.375	0.63	0.56
9 C11L	C11 with LED alarm light	0.062-19.999"	5	0.375	0.63	0.96
11 C11E	For ID cylinder walls .2" radius	0.062-1.000"	5	0.125 x 0.375	0.63	0.56
12 C13	C11 but smaller size	0.062-19.999"	5	0.250	0.45	0.55
C14	C11 subminiature with top connector	0.062-2.000"	5	0.125	0.32	1.16
8 C16	For more attenuative materials	0.200-19.999"	2.25	0.500	0.75	0.61
7 C16L	C16 with LED alarm light. C16 with LED	0.200-19.999"	2.25	0.500	0.75	1.05
8 C17	Very high power on attenuative materials	2.00-199.9"	2.25	0.500	0.75	0.61

MODEL	APPLICATION	THICKNESS RANGE	ELEMENT		CASE SIZE-INCHES	
			FREQ. MHz.	DIA. IN.	DIA.	HEIGHT
IBU-5	Sharp focused type bubbler immersion transducer with plastic cone and metal tip. Use only oscilloscope monitoring.	0.0500-0.7000"	5	0.250	0.88	2.10
IBU-10		0.0300-0.7000"	10	0.250	0.88	2.10
IBU-15		0.0150-0.6000"	15	0.250	0.88	2.10
IBU-25		0.0120-0.5000"	20	0.250	0.88	2.10
E11877		0.0090-0.2000"	30	0.250	0.88	2.10
IBU-C	Replacement plastic cone for IBU models					
IBU-T	Replacement plastic tips (5) for IBU models					
T-300	Bubble tank for IBU models with pump; tank and holder for transducer.					



Miscellaneous Bubbler & Pencil Probes

MODEL	APPLICATION	THICKNESS	ELEMENT		CASE SIZE - INCHES		ACCESSORIES
			FREQ. Mhz	DIA. IN.	DIA.	HEIGHT	
D11 5	General purpose on thin smooth materials. Fixed delay	0.0050-0.7000"	15	0.250	0.45	0.81	
D11TC	D11 with top connector	0.0050-0.7000"	15	0.250	0.45	0.90	
D11R 2	D11 with replaceable delay 0.29" tip diameter	0.0050-0.7000"	15	0.250	0.50	0.90	D11R-T replacement tips
D11RTC 4	D11R with top connector	0.0050-0.7000"	15	0.250	0.50	1.12	
D11L	D11 with LED alarm light	0.0050-0.7000"	15	0.250	0.45	1.19	
D12 6	Similar to D11 with smaller housing and element	0.0500-0.3000"	15	0.188	0.32	1.16	
D13R 1	For more attenuative materials with smooth surfaces	0.4000-1.000"	10	0.500	0.89 0.55 tip	1.25	D13R-T replacement tips
D15	For use on plastic-backed metals (chem-mill) or bonded face sheet laminates	0.0050-0.2500"	15	0.250	0.45	0.70	
D15L	D15 with LED alarm light	0.0050-0.2500"	15	0.250	0.45	1.20	
D16R 2	D11R with extended delay tip and thickness range	0.0250-1.100"	15	0.250	0.45	1.00	D16R-T replacement tips
D17	D15 for thicker materials	0.0220-0.700"	15	0.250	0.45	0.81	
D20R 14	D11 with replaceable delay 0.125" tip diameter	0.0050-0.7000"	15	0.125	0.50	0.90	
DM-123 17	Swivel-mounted on 4" handle. Use only with oscilloscope monitoring	0.0050-0.4000"	15	0.125 x 0.313	0.30 x 0.50	0.35	
AEX-01C 16	Focused beam with .060" diameter replaceable tip and pencil style case. For use on irregular surfaces when used with scope display.	0.0100-0.3100"	12	0.188	0.37	4.50	AEX-T replacement tips
AEX-02C 16	AEX-01C with permanent tip	0.0400-0.3100"	12	0.188	0.37	4.50	
AEX-03C 15	AEX-01C right angle style	0.0100-0.3100"	12	0.188	0.37	4.25	AEX-T
AEX-04C 15	AEX-02C right angle style	0.0100-0.3100"	12	0.188	0.37	4.25	



## Cables and Adapters

NDT Systems offers cables and adapters for connecting our Optima and Nova series of transducers, as well as virtually any other brand of transducer to a variety of ultrasonic instrumentation and other equipment. These cables are designed and manufactured with reinforced junctions between the cable and connector. There are also rugged cable types which will extend the life of your cable. Coupled with the variety of standard and optional transducer connectors offered in this catalog and throughout industry, these low cost cables and adapters provide simple and reliable interconnections with existing instrumentation. If the cable you are looking for is not here please feel free to contact us.

Cables				
Model	End - 1		End -2	Cable Type
MB-01	Microdot	M	BNC	M RG-174
MU-01	Microdot	M	UHF	M RG-174
ML-01	Microdot	M	Lemo-00	M RG-174
ML-02	Microdot	M	Lemo-1	M RG-174
MBR-01	Microdot	M	BNC	M RG-174 Heavy Duty
MRL-01	Microdot	M	Lemo-00 Right Angle	M RG-174
BB-01	BNC	M	BNC	M RG-174
BB-02	BNC	M	BNC	M RG-58A/U
BU-01	BNC	M	UHF	M RG-174
BU-02	BNC	M	UHF	M RG-58A/U Waterproof
BL-01	BNC	M	LEMO-00	M RG-174
BL-02	BNC	M	Lemo-1	M RG-174
BS-01	BNC	M	Selectro	M RG-174
BBR-01	BNC	M	BNC	M RG-174 Heavy Duty
BMR-01	BNC	M	Microdot Right Angle	M RG-174
BRL-01	BNC	M	Lemo-00	M RG-174
UU-01	UHF	M	UHF	M RG-174
UU-02	UHF	M	UHF	M RG-58A/U Waterproof
UL-01	UHF	M	Lemo-1	M RG-58A/U
DMB-01	Dual Microdot	M	Dual BNC	M RG-174
DBB-01	Dual BNC	M	Dual BNC	M RG-174
DBL-01	Dual BNC	M	Dual Lemo-00	M RG-174
DML-01	Dual Microdot	M	Dual Lemo-00	M RG-174
DML-02	Dual Microdot	M	Dual Lemo-1	M RG-174
DBS-01	Dual BNC	M	Dual Selectro	M RG-174
LL-01	Lemo-00	M	Lemo-00	M RG-174

Adapters				
Model	End - 1		End - 2	
ABU-01	BNC	M	UHF	F
ABU-02	BNC	M	UHF	M
ALB-01	Lemo-1	F	BNC	M
ALB-02	Lemo-00	M	BNC	F
ABB-01	BNC	F	BNC	F
AUU-01	UHF	F	UHF	F
AFU-01	UHF	M	Flange**	F
AUR-01	UHF-RA	M	UHF	F
AUR-02	UHF-45°	M	UHF	F
ABT-01	BNC 'T' Adapter			

\*\* For use in 1" search tubes

Search Tubes	
Model	Length
SW-01	1"
SW-02	2"
SW-04	4"
SW-06	6"
SW-12	12"
SW-18	18"
SW-24	24"
SW-36	36"

Angle Reflectors	
Model	Transducer Style
LAR-3	Use With 'A' Style Immersion
LAR-5	Use With 'B' Style Immersion

90° unless specified otherwise

# Test Blocks

## Reference Standards

NDT Systems offers a complete selection of standard and custom Ultrasonic Reference Standards (also referred to as test blocks or calibration blocks). Manufactured to exacting tolerances, all Reference Standards are made from metal stocks that have been ultrasonically inspected prior to fabrication. Finished test blocks are inspected in accordance with MIL-I-45208 and with electronic instruments calibrated in accordance with MIL-C-45662, which requires traceability to NIST (formerly National Bureau of Standards).

To inhibit corrosion, Reference Standards made from steel alloys are nickel-plated and aluminum blocks are clear anodized. Attractive hardwood cases are available for all models to further protect the test blocks and facilitate handling and storage. Most markings are permanently engraved (where permitted) or electro-etched if engraving will interfere with function.

Standard steel blocks are available in A36, 1018 or 4340 (vacuum melted). Aluminum blocks are standard in 7075-T6 and stainless steel in Type 304. Other materials are available for custom requirements, and blocks can be fabricated from customer furnished materials.

## Some of the more popular Reference Standards Include:

### IIW Type 1

Used to verify angle beam transducer beam exit point and beam angle per AWS, International Institute of Welding, and other standards and procedures.

### IIW Type 2

Contains most of the features of the IIW TYPE 1 block, with the addition of a part-through 2.00 inches radius centered at the same place as the 4.00 inches radius. Has three additional side-drilled holes, 3/64 inch, 5/64 inch and 8/64 inch diameter.

### Mini IIW Type 2 style

Fundamentally a half size IIW Block, but weighing only about one-fourth as much. Has co-centered 2.00 inches and 1.00 inch radii, and a variety of milled surfaces to extend to the usefulness of this block for calibrating both longitudinal and shear wave setups. The block is 1.00 inch thick with a 1.00 inch diameter hole and three side-drilled holes 3/64, 5/64 and 8/64 inch in diameter. Includes engraved beam angle markers.

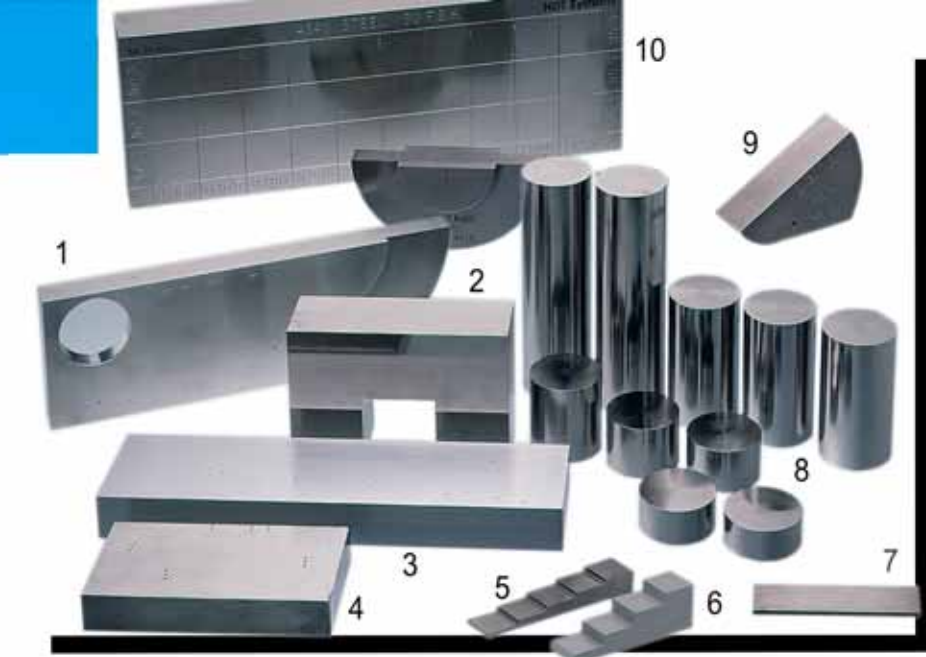

Description	Test Block Model Numbers			
	Steel	Alum.	Stainless	Case
DC - Shearwave Distance Calibration	TBS101 (1)	TBA101	TBSS101	TBC101
SC - Shearwave Sensitivity Calibration	TBS102 (1)	TBA102	TBSS102	TBC102
DSC - Shearwave Distance / Sensitivity	9 TBS103 (1,2)	TBA103	TBSS103	TBC103
ANGLE BEAM (Miniature)	TBS104 (1,2)	TBA104	TBSS104	TBC104
AWS RESOLUTION	4 TBS104 (1,2)	TBA104	TBSS104	TBC104
30 FBH RESOLUTION	10 TBS106 (3)	TBA106	TBSS106	TBC106
MINIATURE RESOLUTION	7 TBS107 (1)	TBA107	TBSS107	TBC107
ASME N-625 REFERENCE PLATE	TBS108 (1)	TBA108	TBSS108	TBC108
IIW TYPE 1	TBS109 (1,2)	TBA109	TBSS109	TBC109
IIW TYPE 2	1 TBS110 (1,2)	TBA110	TBSS110	TBC110
NAVSHIPS	3 TBS111 (1)	TBA111	TBSS111	TBC111
IOW BEAM PROFILE	TBS112 (1)	TBA112	TBSS112	TBC112
4-STEP BLOCK	6 TBS113 (3)	TBA113	TBSS113	TBC113
5-STEP BLOCK	5 TBS114 (3)	TBA114	TBSS114	TBC114
DS - Distance/ Sensitivity	TBS115 (1)	TBA115	TBSS115	TBC115
MINI IIW-TYPE	TBS116 (1)	TBA116	TBSS116	TBC116
DISTANCE/AREA AMPLITUDE (10)	8 TBS120 (3)	TBA120	TBSS120	TBC120
AREA/AMPLITUDE (8)	TBS121 (3)	TBA121	TBSS121	TBC121
AREA/AMPLITUDE (19), #3 FBH	TBS122-3 (3)	TBA122-3	TBSS122-3	TBC122
AREA/AMPLITUDE (19), #5 FBH	TBS122-5 (3)	TBA122-5	TBSS122-5	TBC122
AREA/AMPLITUDE (19), #8 FBH	TBS122-8 (3)	TBA122-8	TBSS122-8	TBC122
INDIVIDUAL ASTM BLOCKS	Inquire	Inquire	Inquire	-----
ASME BASIC CALIBRATION BLOCKS	Inquire	Inquire	-----	Inquire

## Metals Available-Standard

Steel (1) AISI 1018 (Nickel Plated) (2) A36 (Nickel Plated) (3) 4340 Vacuum Melt (Nickel Plated) Aluminum - 7075-T6 (Clear Anodized) Stainless Steel - Type 304

### AWS Resolution Block

Angle Beam Lock per AWS for verifying the flaw-near-flaw resolution of shearwave transducers. Contains three sets of three closely-spaced side-drilled holes. Each hole is 0.062 inch diameter. Engraved index markers are provided for 45°, 60°, and 70° refracted angle beams.

### Miniature Resolution

Longitudinal Wave Block for the determination of near-surface resolution and sensitivity. Can be used for calibration of high resolution thickness gages in the range from 0.015 inch to 0.125 inch. Contains four slots 3/16 inch wide x 5/8 inch long, with metal paths of 0.015, 0.020, 0.025, and 0.030 inch, and two sets of flat-bottomed holes, 1/64 inch and 3/64 inch diameter with metal path distances of 0.020 inch, 0.025 inch, and 0.030 inch.

### 4 Step Cal Block

Used for thickness/distance calibrations, this block has steps with thickness increments of 0.250, 0.500, 0.750, and 1.00 inch. The area of each step is 0.75 inch x 0.75 inch.

### 5 Step Cal Block

Similar to the 4-Step block, but with 5 steps of 0.100, 0.200, 0.300, 0.400, and 0.500 inch thickness.

### DSC

Shearwave Distance/Sensitivity Calibration Block per AWS. Has 1.00 inch radius and 3.00 inches radius, 1.00 inch thick. The 3.00 inches radius has a centered slot 0.375 inch deep x 0.031 inch wide. Contains a 0.125 inch diameter side-drilled hole and engraved markings for determination of beam angles in the ranges of 45°, 60°, and 70°.

# Custom Engineered Transducers



**1,2,3** Miniture side-looking focused imersion transducers for wall thicknessmeasurements and flaw detection. Ideal for small diameter tube inspection from the ID (0.160" minimum diameter) These high resolution transducers are available in 10, 15 and 20 MHz.

**4** The interchangeable Pencil Probe AEX05C consists of a removable "head" that can be mounted on a handle in either the "straight" or "right angle" configuration by means of two Microdot connectors located at right angle.

**5** Miniture Right Angle Pencil Probe AE12205 is ideal for access in small clearance areas (as low as 0.350") such as adjacent turbine blades.

**6** Miniture immersion transducer: 3mm (0.118") diameter by 3mm long case. Available in 5,10, and 15MHz.

**7** "Pencil" Quartz delay line transducer for thickness readings (as low as 0.003" in steel). The contact area of the transducer is 0.175".

**8** D21-R is a small diameter (0.100") removable delay line transducer.

**9** Thickness measurement contact transducer with plastic face and water feed through the center of the transducer element. Suitable for testing of composites, when continuous water coupling is necessary.

**10** Low profile (0.100") contact transducer available in 5, 10, and 15 MHz.

**11** Special "yoke" contact transducer for measuring of pressure in gas bottles (like the ones used for airbags).

**12** Paintbrush transducers: 3" x 0.25", 2" x 0.25", 1.5" x 0.25" available in frequencies up to 10MHz.

## Custom Transducers and Application Studies

NDT Systems has extensive experience in the engineering, design and development of special and custom transducers for unusual or complex geometry applications. Being a leading manufacturer of all types of ultrasonic instrumentation, we can produce optimized transducer designs for virtually any non-standard thickness gaging, flaw detection or bond testing application. In addition, a complete applications laboratory is available to customers needing transducer application and feasibility studies.

NDT Systems invites you to discuss special transducer requirements with our Engineering Development Laboratory personnel. Learn why our thorough, one-on-one treatment has produced an extensive clientele for our custom designers.

## Application Studies

NDT Systems maintains a fully equipped Applications Laboratory for performing and evaluating both transducer applications and general nondestructive testing applications. Customers are invited to submit test specimens or product samples for analysis and recommendations.

In most cases, routine applications studies are conducted without cost to the customer. If a practical application results, you will be promptly contacted and advised of the most appropriate transducer and/or instrumentation selection for you specific needs.

If a demonstration is required, a qualified NDT Systems technical field sales representative will call to arrange a hands-on demonstration using your test sample and the equipment and techniques we, through actual testing, have determined to best suit your needs.

Without obligation to purchase, and at a location and time of convenience, you will be shown the full capability of our recommendations to solve your problem.

# Optima ELITE

Composite Element Transducers

**Seeing IS Believing!**



Freq. MHz	Optima Elite Composite Transducers			
	Series	0.250"	0.375"	0.500"
1.0	Fingertip Contact	CFC012	CFC013	CFC014
	Quick Change Angle Beam	TAC012	TAC013	TAC014
	Immersion (Pencil Type)	IAC012	-----	-----
	Immersion (Slim Case)	IBC012	IBC013	IBC014
2.25	Fingertip Contact	CFC022	CFC023	CFC024
	Quick Change Angle Beam	TAC022	TAC023	TAC024
	Immersion (Pencil Type)	IAC022	-----	-----
	Immersion (Slim Case)	IBC022	IBC023	IBC024
5.0	Fingertip Contact	CFC052	CFC053	CFC054
	Quick Change Angle Beam	TAC052	TAC053	TAC054
	Immersion (Pencil Type)	IAC052	-----	-----
	Immersion (Slim Case)	IBC052	IBC053	IBC054

The Optima ELITE series of Piezo-Composite Transducers defines a new class of ultrasonic testing capability.

In many applications, Piezo-Composite Transducers can significantly increase both gain and signal to noise ratio in highly attenuative materials such as cast iron, stainless steel, composite and fiberglass materials to mention a few.

The Optima ELITE Series offers a very good alternative to conventional broad band ceramic transducers without the sacrifice in sensitivity.

They also offer the gain benefits of typical narrower banded, high gain PZT type transducers while, again maintaining sensitivity & improved signal to noise ratio.

The Optima Elite Series is offered in Quick Change Angle Beam models as well as immersion contact and dual element models.

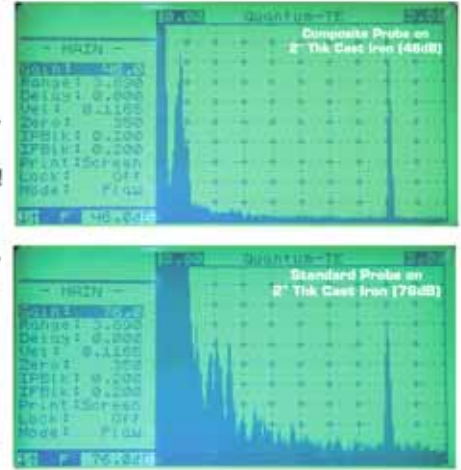
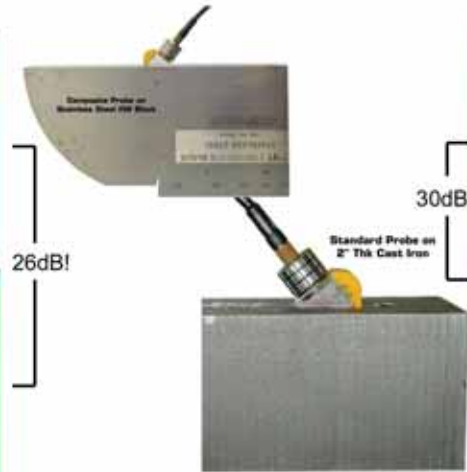
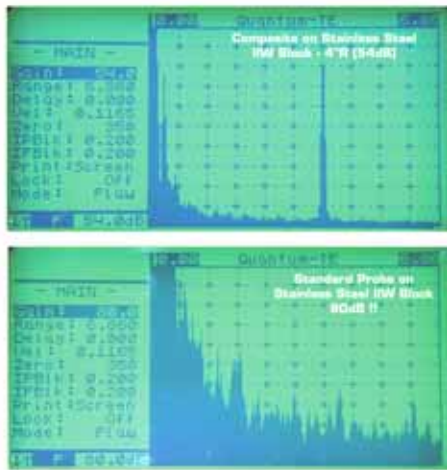
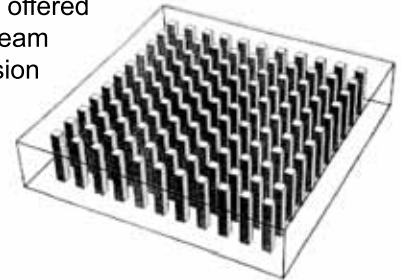

The above illustrations demonstrate the incredible differences the correct transducer can make in an application. In both cases we compared our standard line Optima series transducers to our all new Optima ELITE series. The transducers were a 5 MHz, 3/8" Diameter threaded into a 45°, Quick Change shear wave wedge. Notice the gain difference attained in these tests! Ask us how we compared against the competition.

When using Composite Transducers, the greatest advantage is had when the transducer is initially coupled to a low

acoustic impedance material such as Lucite or water. Improvements from 10 to 20+ dB are possible under these conditions.

Generally one would tend to use a 2.25 MHz conventional transducer to resolve material as attenuative as these samples. Call NDT Systems today for the name of a representative in your area for a demonstration of the latest available technology in ultrasonic transducers.



Specifications subject to change without notice. (E & O.E.)



**Advanced NDT Limited**  
Unit 4 Elgar Business Centre  
Moseley Road  
Hallow, Worcester  
WR2 6NJ, England  
Tel: 01905 371460

**AdvancedNDT**

Web: [www.advanced-ndt.co.uk](http://www.advanced-ndt.co.uk)  
Email: [sales@advanced-ndt.co.uk](mailto:sales@advanced-ndt.co.uk)