



# BEACONS



## 7660 RotoLED™ R65 Class I LED Hybrid

The 7660 Series beacon combines all the major benefits of the latest LEDs with the unmistakable warning signal of a rotator, all without compromising reliability. LED hybrid technology uses a brushless magnetic drive system to spin the reflector disk, reducing noise and eliminating the typical motor/gear drawbacks associated with conventional rotators. The 7660 also features eight high-intensity LEDs and a TIR optic to provide R65 Class I light output. Additional benefits include low amp draw, extended service-free life, and a 5-year warranty.

### Models

PART NO.	VOLTAGE	AMPS	FPM	COLOUR	MOUNT
7660A	12-24	2.3	125	Amber	3 Bolt Flange/1" Pipe

### Features and Benefits

- LED hybrid technology provides a high intensity rotating warning signal with no gears, brushes or bulbs to wear out
- Eight high-intensity LEDs combined with a TIR optic
- UV hard coated lens to greatly reduce cracking, hazing, abrasion and fading
- Universal bolt pattern for simple mounting
- Temperature Range: -30°C to +50°C

### Dimensions

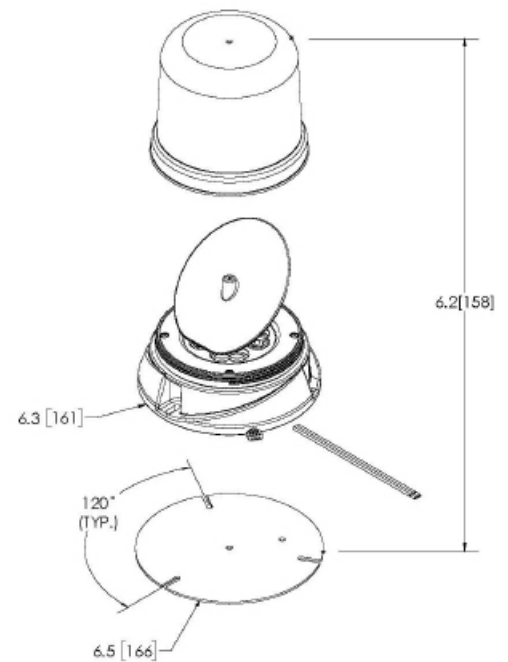

45° angled reflector driven by a quiet brushless magnetic drive system provides an exceptional warning beam without compromising reliability

Eight high intensity, 3-watt LEDs combined with a unique TIR optic project light onto the reflector to provide R65 Class I light output

Unique base design efficiently dissipates heat from the LEDs

