



DIRECTIONALS



3811 SERIES

Surface Mount

3811 Series directional LEDs feature 20 high intensity LEDs with individual reflectors to provide truly outstanding light output in a very cost-effective package. Featuring seven flash patterns and synchronisation capability, offering fit-and-forget maintenance-free operation and low amp draw.

Models

PART NO.	VOLTAGE	AMPS	MOUNT
3811X	12-24	0.4	Surface

Replace X in part number with desired color: A=amber, B=blue, C=clear, R=red

Features and Benefits

- Tough, clear polycarbonate housing with encapsulated electronics
- Seven flash patterns
- Synchronisable with additional units
- Discrete units are colourless when not illuminated
- Temperature Range: -30°C to +50°C

Dimensions

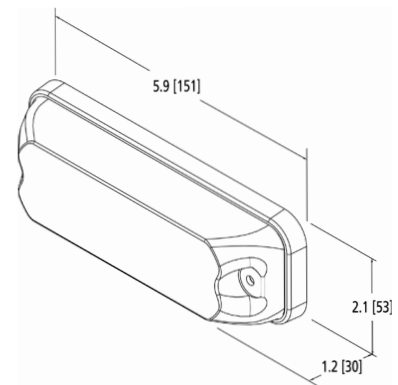

Flash Patterns (7)

- Single
- Double
- Quad
- NFPA Quad
- Fast Single
- Fast Double
- Fast Quad