



## DIRECTIONALS



### 3715/3725 SERIES

#### Surface Mount

This compact and versatile LED directional light is ideal for applications requiring high intensity output, low current draw and maintenance-free operation. These premium LED heads feature a clear polycarbonate lens with LEDs that illuminate in the colour of your choice. Warning capability can be customised by selecting from nine flash patterns (via a trigger wire) and synchronising multiple heads simultaneously or alternately. With epoxysealed electronics, these light heads are one of the most rugged and flexible LED products around.

#### Models

PART NO.	VOLTAGE	AMPS	MOUNT
3715A	12	0.4	Surface
3715B	12	0.4	Surface
3725A	24	0.2	Surface
3725B	24	0.2	Surface

#### Features and Benefits

- Nine flash patterns
- Multiple heads are synchronisable (simultaneous or alternating operation)
- Epoxy-encapsulated electronics provide environmental protection against dust, moisture & vibration
- Four high-intensity LEDs combine with TIR optics to provide high intensity directional warning
- Units are colourless when not illuminated
- Temperature Range: -30°C to +50°C

#### Dimensions

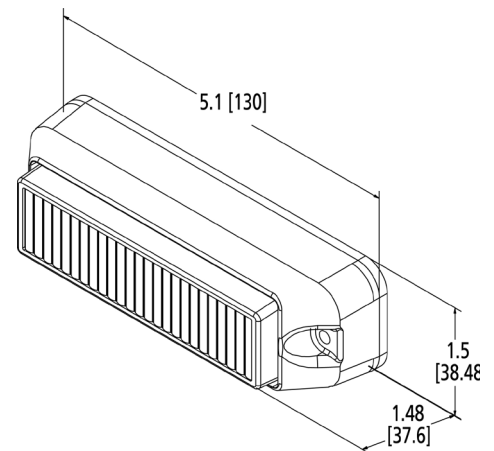

#### Flash Patterns

- Steady Burn
- Double
- Quad
- Quint Hold
- Fast Double
- Double Alternate
- Quad Alternate
- Quint Hold Alternate
- Fast Double Alternate