



ALARMS



800 Series OEM Mounting Pattern

Designed to meet all the harsh operational requirements of any fleets equipment, ECCO's 800 Series alarms feature a reverse-mounted speaker design and reinforced nylon housing providing unrivaled durability. These alarms are so robust that an ECCOLIFE™ warranty covering the alarm for the life of the vehicle is offered on all models. These 800 Series alarm models feature a mounting bracket with the same mounting pattern popular with OEM's. Smart Alarm® models measure ambient noise and adjust their sound level, creating a volume that is safe without being annoying or contributing to noise pollution. Smart Alarms eliminate the need for constant manual adjustment and help prevent intentional alarm disconnection.

Models

PART NO.	TYPE	VOLTAGE	dB(A)	AMPS	APPROVALS
914N-001	Smart	12-24	87-112	1.5	SAE Type F, CE, R10
876N-001	-	12-36	112	1.3	SAE Type A, CE, R10, UL, AMECA

Features and Benefits

- Mounting basket features popular OEM footprint
- Reverse-mounted speaker enhances sound and protects the speaker from dust and moisture ingress
- Reinforced nylon housing eliminates corrosion damage
- Sealed in epoxy for protection against dust, moisture and vibration
- Temperature Range: -40°C to +85°C

Dimensions

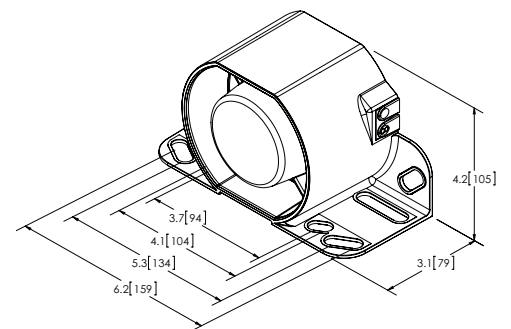

Alarm Specifications

Connection: 16 AWG blunt cut wires
 Reinforced nylon housing
 Recommended mounting bolt:
 Bottom: 3/8-16 UNC Grade 5 or better
 Recommended washer:
 Bottom: 3/8" Type A Series N washer
 Recommended mounting torque:
 Bottom: 276 in. lbs.