



Model TB45-4  
Shown with  
optional Access  
Receivers

# ACCURATE GRAVIMETRIC BLENDING IN VERY SMALL BATCHES

Get accurate blends, better mixing, faster material changes and increased profits with Conair's TrueBlend Series Blenders. Steep-sided material compartments allow resin to flow evenly and freely through vertical dispense valves into the weigh chamber. Efficient mixing assures full integration of all recipe ingredients. Fully enclosed cabinet design assures no pellet spillage and clean operation. Standard convenient features such as quick access material compartment bins, a hinged chassis access door and removable components in the mixing chamber reduce downtime during cleanout.

## THROUGHPUT RATES TO 175 POUNDS AN HOUR

The TrueBlend TB45 series blenders offer small extruders and small tonnage injection molding machines a superior way to blend color and additives centrally or at the throat of the processing machine.

The blender dispenses up to four materials from respective material compartments into a common weigh chamber. The control determines the correct weight of each ingredient based on setpoints entered on the touch screen display. Up to 1000 recipes and 250 resin names can be entered and stored in the processor.

Unique fast-acting "no stick" vertical valves control the amount of material dispensed. All dispense valves use two-way air cylinders assuring positive operation.

Choose between throat mounted or central blender models. Options include an integrated blender/loader control feature, and a flow control valve for central blending applications.

### ■ Blend accuracy to 1/2 of 1%

Colorant and/or additive weights are held to within 0.5% of setting. A selectable Precision Additive™ feature is also available for additives. The microprocessor control automatically calibrates after every cycle and compensates for variations in dispense method, resin bulk density or particle geometry.

### ■ Easy-to-use control

Intuitive 5.7 inch LCD touch screen control with full color graphics allows quick and easy setup of blender setpoints. All setpoints are displayed simultaneously. Enter the percentages of the blend on the touch screen display and the blender does the rest. The system automatically weighs the recipe ingredients in the proper sequence and maintains the correct blend relationship. Any position can be identified as one of the four material type selections adding flexibility to your application setup.



### ■ Convenient, easy clean out

Easy access to all material contact points for fast and safe cleaning during color or resin changes. Quick access material compartment bins, a removable weigh bin, mix agitator and mix chamber liner allow quick efficient cleaning. The blender features a built-in material shutoff valve below the mixing chamber, this can be replaced with the automatic flow control valve for remote and central blending applications.



**TRUEBLEND™ TB45-4**

**FEATURES**

**Intuitive, SB-2 touch screen control offers the industry’s best multi-component accuracy**

This easy-to-use touch screen control allows for fast setup of blender setpoints and automatically weighs recipe ingredients in the proper sequence to maintain correct blend relationship. Any position can be identified as one of the four material type selections adding flexibility to your application setup.



**Instantly see your materials usage**

Material usage / totals screen tracks the number of batches, weights dispensed by bin and weight dispensed in total since the last reset.

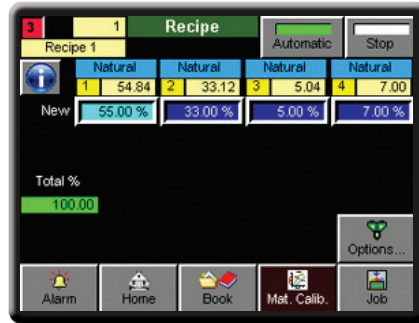

**View and make changes to the active recipe**

Save and recall up to 1000 recipes and 250 resin names in the Recipe Book.

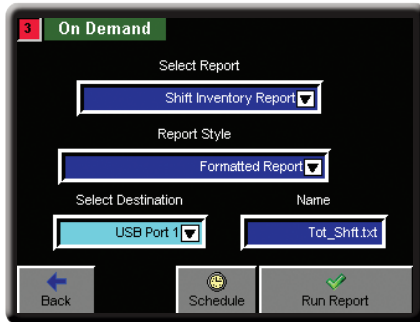

**Built-in reporting capabilities**

Every SB-2 blender control is equipped with the capability to help users track their settings, alarms, material consumption, shift and inventory needs.

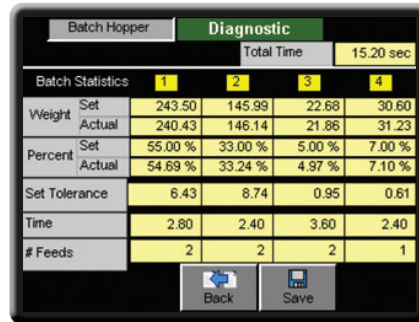

**On-call diagnostics**

Diagnostic screen displays target set point percentage and actual percentage dispensed. Also displays start and finish weights for each material per batch. Verifies true and accurate blend performance.

**SmartBlend™ SB-2**

Premium touch screen control offers these high performance functions to target the unique process needs of molders and extruders.

- Best choice for the needs of rapidly changing custom jobs or sophisticated extrusion and molding applications with complex and highly critical recipes.
- Progressively approaches each ingredient target. Never overshoots.
- Precision metering yields industry’s best batch-to-batch accuracy.
- Precision ratio control - all components.
- Individual material accuracy settings.
- SMS or text message alarm notification capable.
- VNC viewer



**WHICH PACKAGE IS RIGHT FOR YOU?**

STANDARD PACKAGES - 4 Component	TS	LS*
<b>FEATURES</b>		
Material bin sight glasses	●	●
Touch screen control	●	●
Loading control option		●
Material bin finger guards	●	●
Machine mount with manual slide gate discharge†	●	●
Remote/bin mount with pneumatic slide gate discharge†	●	●

**FEATURE NOTES:**

\* Includes an optional integrated loader control feature.

† Choose between either machine or remote mounted blender packages.

Specifications may change without notice. Consult with a Conair representative for the most current information.



## FEATURES

### Simple and quick cleanout



Easy access to all material contact points for fast and safe cleaning during color or resin changes. Material compartment access doors, removable weigh bin, mix agitator and mix chamber liner allow quick, efficient cleaning.

### Optional floor stand design



Blender installs easily to this floor stand, which is equipped with a material reservoir.

Each blender stand features:

- Sturdy design
- Easy cleanout
- Fork-lift provisions
- Drawer magnet provision
- One standard material takeaway tube (up to two additional material tubes are available as options)
- Available with one or two cubic foot reservoir capacities
- Optional casters (model TBBS01 only)

## OPTIONS

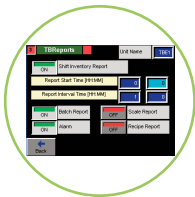

#### TB reports

Used to track and document material usage, alarms, batch and shift reports and recipes. See *TrueBlend Reporting Software and ControlWorks specification sheets*.



#### Air blow-off for mix chamber level sensor

This feature is integrated into the blender mix chamber to blow excessive dust and fines away from the sensing device and ensure accurate level sensor reading.



#### Material level alarm control

Eliminate costly material shortage problems and machine downtime with this early warning system. The control monitors up to six material levels at one blender. Individual switches can be adjusted to monitor high or low material levels. See *Level Alarm Control specification sheet*.



#### Remote mixer demand sensor

This sensor provides a fill-to level option in a surge bin or other material receptacle that sits below a remote mounted blender.



#### Drain chute

The material drain chute readily installs to the chassis opening of the blender for fast and simple cleanout.



#### Remote HMI operator cable

This option is for the 6 meter cable in lieu of the standard 2 meter cable.

SPECIFICATIONS

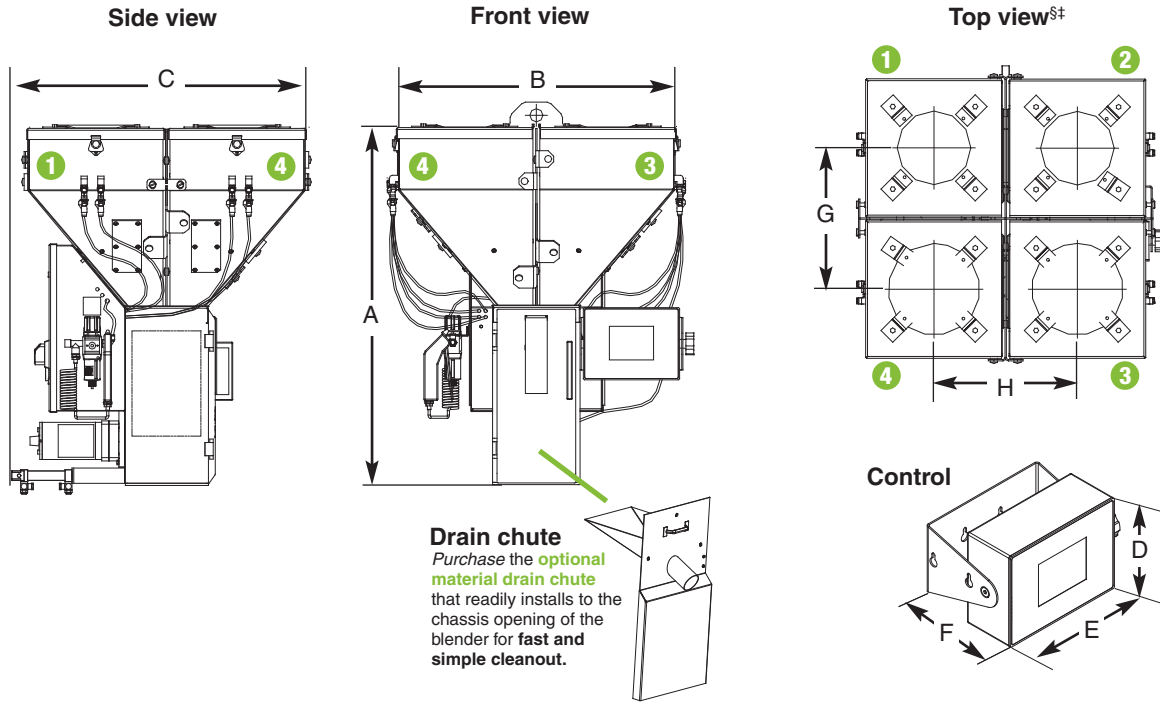

MODELS	TB45-4
<b>Performance characteristics</b>	
Batch size lb {g}	1.0 {450}
Maximum throughput rate lb/hr {kg/hr}*	175 {79}
Bin capacity - main ingredient ft <sup>3</sup> {liter}	0.2 {5.7}
Bin capacity - minor ingredient ft <sup>3</sup> {liter}	0.2 {5.7}
Maximum number of materials	4
Number of vertical discharge valves	4
Number/(size) of major bin valves	2 - (40 mm)
Number/(size) of minor bin valves	2 - (20 mm)
<b>Dimensions inches {mm}</b>	
A - Height above mounting plate <sup>†</sup>	32.50 {825.5}
B - Width	25.00 square {635}
C - Depth	27.00 square {686}
D - Control height	6.50 {165.1}
E - Control width	8.75 {222.3}
F - Control depth	6.75 {171.5}
G - Loader center distance	12.75 {323.9}
H - Loader center distance	12.91 {327.9}
<b>Weight lbs {kg}</b>	
Installed	75 {34}
Shipping	125 {57}
<b>Voltage total amps</b>	
115V/1 phase/60 hz	1.0
230V/1 phase/50 hz	0.5
<b>Compressed air requirements</b>	
Discharge valves	90 psi @ 0.2 ft <sup>3</sup> /min {6 bars @ 0.09 liters/sec}; 1/4 in. NPT fitting
<b>Maximum loader sizes</b>	
8 inch loaders	Number of loaders - 4

**MOUNTING INTERFACE**

Dimensions shown in inches and {mm}.

1-25/32 diameter centered {45}

Mixing chamber access door - this side of the interface.

7-1/2 {190}

5 sq. {127}

7-7/8 {200}

Mounting bolt hole size (4 holes) 7/16 inch {11.0 mm}.  
Predrilled 5 x 5 mounting pattern as standard.

**SPECIFICATION NOTES**

\* Maximum throughput rates are based on 35 lb/ft<sup>3</sup> pelletized material, using all standard valve sizes. Use of reducer inserts will lower the rate shown.

Throughput rates are based on:

- **A 4-position blender recipe** of 20% regrind, 80% natural, 3% color and 2% additive material.

† The optional flow control valve will mount inside the chassis in the space of the manual slide valve. Conair recommends using the optional flow control valve when mounting the blender on a stand, surge bin or hopper.

‡ Hopper positions three and four are supplied with eight inch cover plates as standard.

§ Numbers in top view drawings represent hopper positions.

Specifications may change without notice. Consult with a Conair representative for the most current information.

