

FAG



FAG Induction Heating Devices HEATER

Quality and Safety Redefined

SCHAEFFLER



The New HEATER Generation

Quality and safety redefined!

With the new FAG induction heating devices from the HEATER series, Schaeffler is setting the highest standards in quality and safety.

To make the mounting of bearings and parts even easier and more efficient, all heating devices feature a number of innovative functions that are unique in this product class. And this at an excellent price-performance ratio!

The outstanding performance was tested and certified by TÜV Rheinland.

ADVANTAGES

- + Easy operation and optimized mounting times
- + Very user friendly and cost efficient
- + Controlled heating in ramp control mode (combined temperature-time-mode)
- + Uniform heating of outer ring and inner ring
- + User is protected from magnetic field
- + Demagnetized, stress-relieved parts
- + Easy positioning of large bearings thanks to sliding table
- + High degree of flexibility as accessories include ledges of various sizes
- + Large scope of delivery
- + Ideal for batch mounting
- + **Free warranty extension (5 instead of 3 years)**
- + **Maximum safety for user, heating device, part and machine**



Five Year Warranty

Applications

FAG induction heating devices are ideal for heating

- bearings with a min. bore diameter of 10 mm and a max. outer diameter of 1500 mm.
- bearings with a max. weight of 1200 kg.
- other rotationally symmetric steel parts, such as labyrinth rings, gearwheels, belt pulleys, roll couplings, sleeves, etc.

Induction heating – principle

The heart of FAG induction heating devices is a current carrying coil. In all bench top devices, it is situated inside the HEATER housing (see graphic) and not – as in other devices – in the rolling bearing bore.

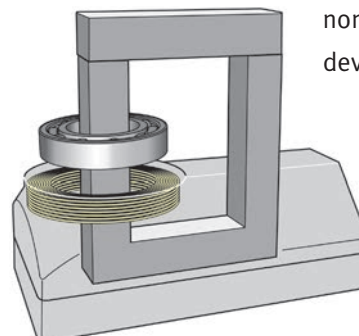

This position permits uniform, controlled heating. The risk of damaging the heating device or part is reduced significantly. While the part to be mounted is heated, non-metallic parts and the device itself remain cool.

FAG HEATER: Uniform, Stress-relieved Induction Heating

SCOPE OF DELIVERY

The scope of delivery of all devices includes (standard accessories): cover // ledges // gloves* // grease



* New gloves, even more heat resistant.

HEATER10

Scope of delivery: standard accessories // optional: carrying case for mobile use

Handy, mobile device for heating small rolling bearings and other rotationally symmetric parts. Ideal for maintenance work, e.g. in cars and electric machines.

- parts of up to 10 kg
- min. bore diameter of 10 mm
- easy to operate
- weighs only 7 kg
- sturdy carrying case for mobile use



HEATER20

Scope of delivery: standard accessories // optional: carrying case for mobile use

Mobile bench top heating device for small rotationally symmetric parts and rolling bearings.

- parts of up to 20 kg
- min. bore diameter of 10 mm
- easy to use
- weighs only 14 kg
- sturdy carrying case for mobile use



HEATER40

Scope of delivery: standard accessories // incl. remote control

For professional mounting work in maintenance workshops and in the production sector. The slewing ledge makes the device easier to operate and simplifies the procedure.

- parts of up to 40 kg
- min. bore diameter of 15 mm
- for stationary use
- slewing ledge simplifies positioning of parts for heating process



HEATER150

Scope of delivery: standard accessories // incl. remote control

Stationary heating device with slewing ledge.

- parts of up to 150 kg
- min. bore diameter of 20 mm
- slewing ledge simplifies positioning of parts for heating process
- 400 Volt technology



HEATER300

Scope of delivery: standard accessories // incl. remote control // optional: trolley

Bench top heating device for heating heavy parts in horizontal or vertical position. Available with a separate trolley for mobile use, with a tray for keeping ledges.

- parts of up to 300 kg
- min. bore diameter of 30 mm
- slewing ledge: simplifies positioning of parts for the heating process, saving time
- 400 Volt technology

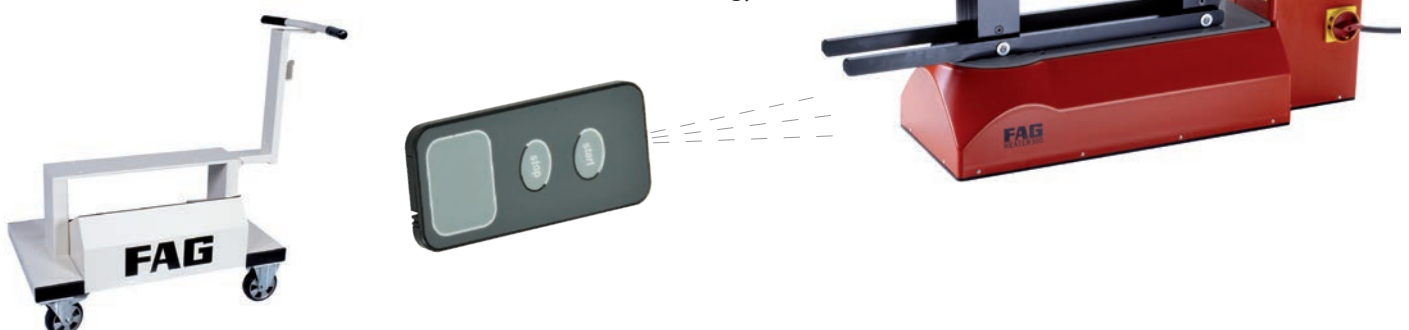

HEATER600

Scope of delivery: standard accessories // incl. remote control & sliding table

Sturdy, powerful standalone device for the expert mounting of heavy parts.

- parts of up to 600 kg
- min. bore diameter of 55 mm
- vertical ledge
- sliding table simplifies positioning of parts for the heating process
- 400 Volt technology



FAG HEATER

Technical Data



Heating devices	HEATER10	HEATER20	HEATER40
Power consumption max. [kVA]	2,3	3,6	3,6
Voltage/frequency [V/Hz]	230/50	230/50	230 /50
Current [A]	10	16	16
Temperature display [°C]	50... 240	50... 240	50... 240
Weight [kg]	7	14	26
Length [mm]	240	345	340
Width [mm]	200	205	240
Height [mm]	255	230	295
Ledge(s) W x H x L [mm] included in scope of delivery	10 x 10 x 125 ¹⁵ 20 x 20 x 125 ³⁰ 30 x 30 x 125 ⁴⁵	14 x 14 x 200 ²⁰ 25 x 25 x 200 ³⁵ 40 x 40 x 200 ⁶⁰	14 x 14 x 280 ²⁰ 30 x 30 x 280 ⁴⁵ 50 x 50 x 280 ⁷⁰
Clear width W [mm] Clear height H [mm]	65 100	120 100	180 160
Part weight max. [kg]	10	20	40
Accessory ledge(s) W x H x L [mm]	7 x 7 x 125 ¹⁰	7 x 7 x 200 ¹⁰ 10 x 10 x 200 ¹⁵ 30 x 30 x 200 ⁴⁵	10 x 10 x 280 ¹⁵ 25 x 25 x 280 ³⁵ 40 x 40 x 280 ⁶⁰

HEATER1200

Scope of delivery: standard accessories // incl. remote control & sliding table

Sturdy, powerful standalone device with an all-steel construction for heating very large parts.

- parts of up to 1200 kg
- min. bore diameter of 95 mm
- outer diameter of up to 1500 mm
- sliding table simplifies mounting of parts for the heating process
- 400 Volt technology



HEATER150	HEATER300	HEATER600	HEATER1200
12,8	12,8	25	40
400 / 50	400 / 50	400 / 50	400 / 50
32	32	63	100
50 ... 240	50 ... 240	50 ... 240	50 ... 240
57	75	350	850
500	1045	1300	1660
290	310	820	1050
480	570	1080	1250
30 x 30 x 350	40 x 40 x 490	100 x 100 x 700	150 x 150 x 850
50 x 50 x 350	60 x 60 x 490		
70 x 70 x 350	80 x 80 x 490		
210	330	430	690
220	265	390	475
150	300	600	1200
14 x 14 x 350	20 x 20 x 490	30 x 30 x 700	60 x 60 x 850
20 x 20 x 350	30 x 30 x 490	40 x 40 x 700	80 x 80 x 850
40 x 40 x 350	50 x 50 x 490	50 x 50 x 700	100 x 100 x 850
60 x 60 x 350	70 x 70 x 490	60 x 60 x 700	
		70 x 70 x 700	
		80 x 80 x 700	
		90 x 90 x 700	

Select the right heating device easily and quickly

FAG Heating Manager is a software for determining the right FAG heating device for your specific application quickly and easily. The selection software can save you a lot of time and makes it easy to find the best solution.

FAG Heating Manager is suitable for everyone who wishes to heat a Schaeffler bearing and is looking for the right FAG heating device for the job. With the help of our bearing database, users can select a bearing

from the entire Schaeffler portfolio. Then the software determines the ideal heating device for that bearing using a special algorithm.

Particularly user-friendly: A list of results is created that includes not only the ideal heating device but also a number of alternatives.

Alternative devices means

- that this heating devices can also be used for the selected bearing.
- but that possible limitations can occur, e.g. a longer heating time.

These alternatives are helpful to customers who – for example – already own an FAG heating device and are wondering whether it can also be used for their application in hand.

FAG Heating Manager is available in German and English and can be downloaded for free from the Media Library on www.schaeffler.com

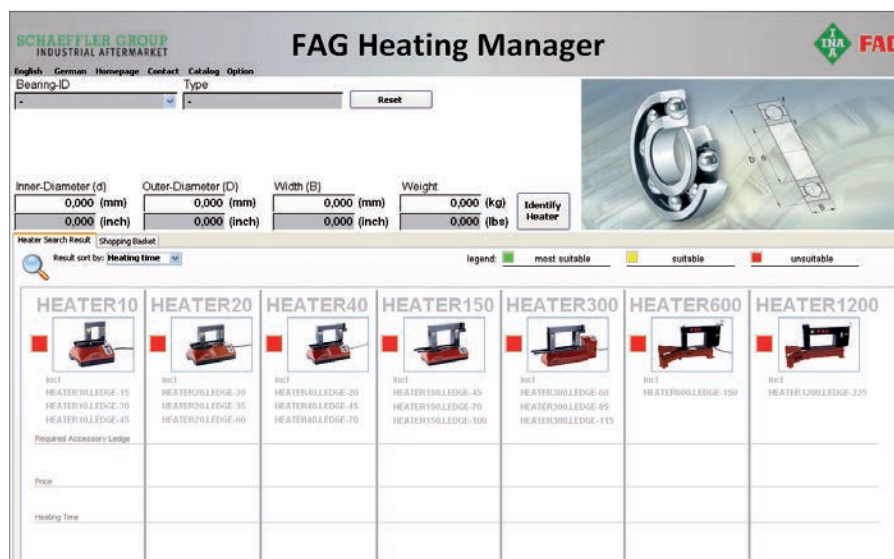

SCHAEFFLER GROUP
INDUSTRIAL AFTERMARKET

FAG Heating Manager







English German Homepage Contact Catalog Option

Bearing-ID: Type:

Inner-Diameter (d): 0,000 (mm) 0,000 (inch)
Outer-Diameter (D): 0,000 (mm) 0,000 (inch)
Width (B): 0,000 (mm) 0,000 (inch)
Weight: 0,000 (kg) 0,000 (lbs)

Heater Search Result Shopping Basket

Result sort by: Heating time Legend: ■ most suitable ■ suitable ■ unsuitable

HEATER10	HEATER20	HEATER40	HEATER150	HEATER300	HEATER600	HEATER1200
						
HEATER10LEGE-15 HEATER10LEGE-30 HEATER10LEGE-45	HEATER20LEGE-20 HEATER20LEGE-35 HEATER20LEGE-60	HEATER40LEGE-20 HEATER40LEGE-45 HEATER40LEGE-70	HEATER150LEGE-45 HEATER150LEGE-70 HEATER150LEGE-100	HEATER300LEGE-60 HEATER300LEGE-95 HEATER300LEGE-115	HEATER600LEGE-150	HEATER1200LEGE-225
Requires Accessory Ledge						
Price						
Heating Time						



All FAG heating devices may be ordered through your local Schaeffler distributor.

Schaeffler Australia Pty Ltd

Level 1, Bldg 8
Forest Central Business Park
49 Frenchs Forest Road
Frenchs Forest, NSW 2086
Australia

Internet www.schaeffler.com.au
E-mail sales.au@schaeffler.com
Phone +61 2 8977 1000
Fax +61 2 9452 4242

Schaeffler New Zealand

(Unit R, Cain Commercial Centre)
20 Cain Road
1135 Penrose
New Zealand

Internet www.schaeffler.co.nz
E-mail sales.nz@schaeffler.com
Phone +64 9 583 1280
Fax +64 9 583 1288

Every care has been taken to ensure the correctness of the information contained in this publication but no liability can be accepted for any errors or omissions. We reserve the right to make technical changes.

© Schaeffler Technologies AG & Co. KG

Issued: 2012, July

This publication or parts thereof may not be reproduced without our permission.