

# MINI K LEVER

TECHNICAL DATA				
		PNEUMATIC	ELECTRIC	BATTERY
ID Locking range	mm (inches)	20 - 42 (0.78-1.65)	20 - 42 (0.78-1.65)	20 - 42 (0.78-1.65)
Idle Speed	gg/min (Rpm)	180	305	151
Max Chuck Torque	Nm (Nm)	6 (6 bar) 18 (8 bar)	17	30
Axial Feeding	mm (inches)	20.5 (0.80)	20.5 (0.80)	20.5 (0.80)
Pneumatic Motor Power	Hp (W)	0.59 (435)		
Air Consumption	NI/min (cfm)	615 (21.7)		
Air Pressure	Bar (psi)	6 ÷ 8 (87 ÷ 116)		
Air Hose Connection	Pollici (inches)	1/2" (1/2")		
Electric Motor Power	W		720	720
Tension	Volt		110 / 230	18V
Frequency	Hz		50 / 60	
Max Acoustic Emission	Db	75	75	75
Machine Weight	Kg	4.8	5.5	5.7

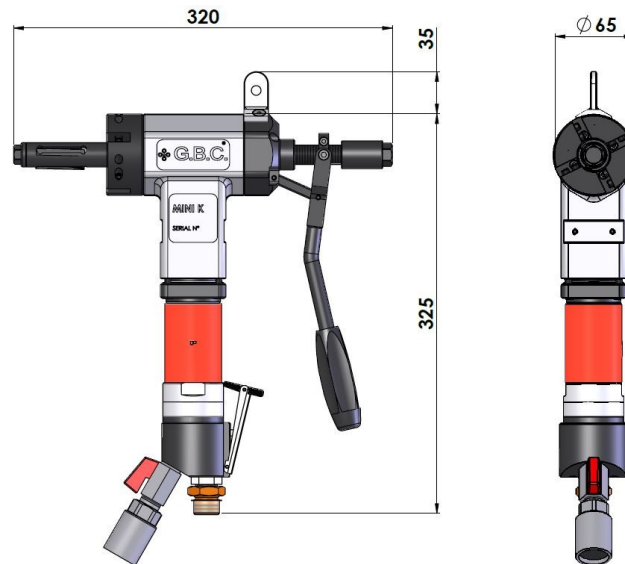

MACHINE DIMENSION				
		PNEUMATIC	ELECTRIC	BATTERY
A	mm (inches)	325 (12.79)	410 (16.14)	470 (18.50)
B	mm (inches)	320 (12.59)	320 (12.59)	320 (12.59)
Ø C	mm (inches)	67 (2.63)	67 (2.63)	67 (2.63)
Ø C (Optional)	mm (inches)	60 (2.36)	60 (2.36)	60 (2.36)