



CHUCK

▶ **P.39~P.53**

Advanced Chuck

Advanced Chuck

**Exclusively designed work
specific chucks for mass
production**

Designed with gripping to accommodate a variety of applications.



CHUCK

Power Wing Chuck PW(C) series

※PWC has the same specification as PW with the exception of the fact that PWC is a compensation type.

Pull back of workpiece for secure gripping of casting or forging PWC compensating type for rough casting through centre



●Powerful Gripping

After gripping the component in a radial direction, a power PULL-BACK action is applied which significantly increases the Gripping Force, allowing a heavier machine cut to be taken.

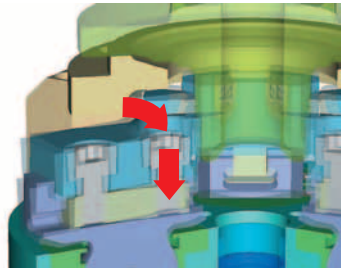

●High Durability

Master jaws are of spherical design and sealed against swarf and coolant. This permits High Gripping Forces to be retained between lubrication periods.

●Complete Sealing

Additional sealing at (1) and (2) reduces grease contamination and increases maintenance period.

●JAW Equalising

5°max equalising angle

Various workpieces can be firmly gripped by the self-equalising jaws to max. 5°.

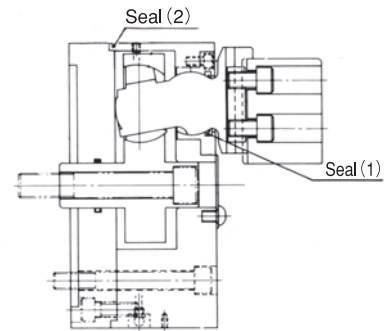
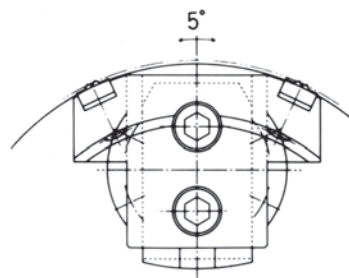

●Gripping on Tapered Parts

The radial and PULL-BACK jaw action allows rough tapered castings and forgings to be securely gripped to maximum 20°.

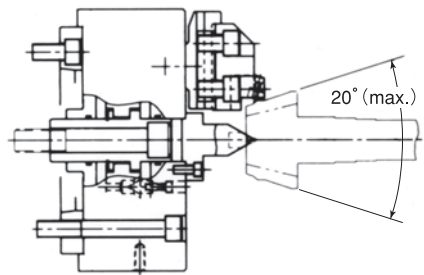

■Type of the gripping pieces

U-Type *The type of the gripping pieces is selected according to the work conditions.

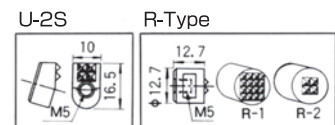
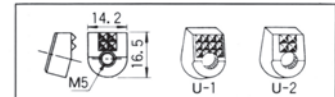

*CE correspondence

Work Examples

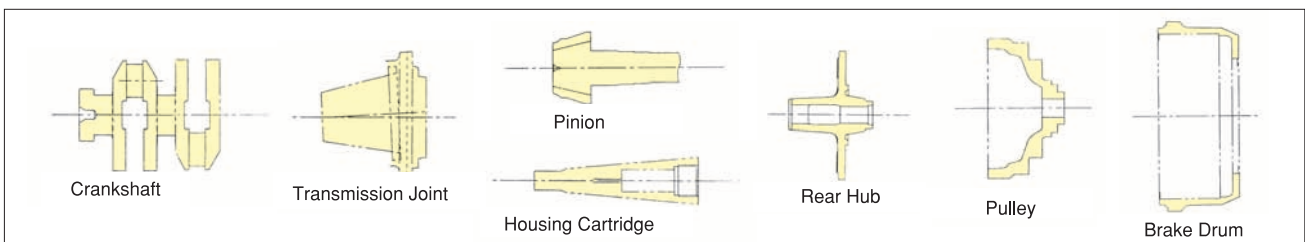

Gripping Examples

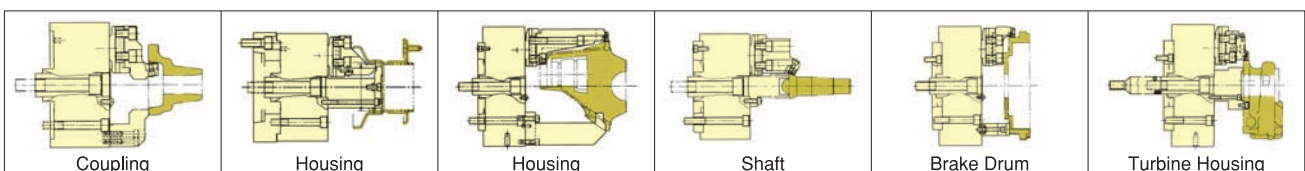

Dimensional Drawings

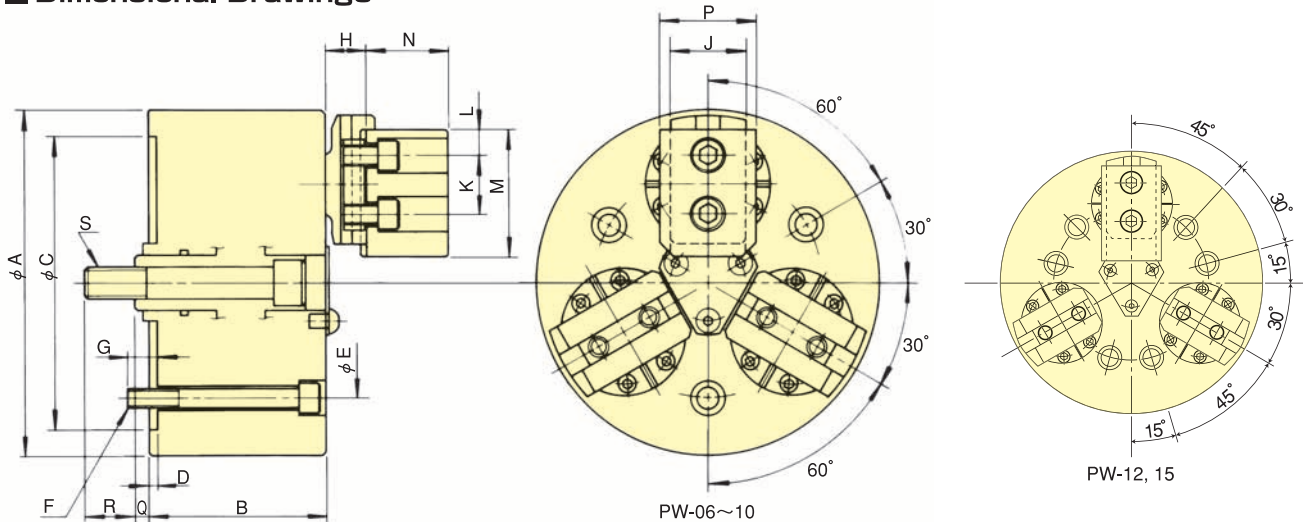

Dimensions

Dimensions Model	A	B	C(H6)	D	E	F	G	H	J
PW-06	162	77	140	5	104.8	3-M10	14	19.3	38.07
PW-08	200	88	170	5	133.4	3-M12	18	23.33	44.45
PW-10	254	105	220	5	171.4	3-M16	25	29.14	57.1
PW-12	300	105	220	5	171.4	6-M16	25	29.14	57.1
PW-15	381	117	300	5	235	6-M20	30	32.4	66.62

Dimensions Model	K	L	M	N	P	Q max.	Q min.	R	S
PW-06	29.36	15	67.5	47.7	50.8	24	12.6	25.4	M16
PW-08	34.14	15	74	54.17	57	29.3	15.1	29.2	M18
PW-10	44.45	19	89.5	66.9	70.1	34.9	17.4	34.7	M22
PW-12	44.45	19	108.5	66.9	70.1	34.9	17.4	34.7	M22
PW-15	53.98	23.9	140	73.2	76.2	48.7	26.3	41	M27

Gripping Performance

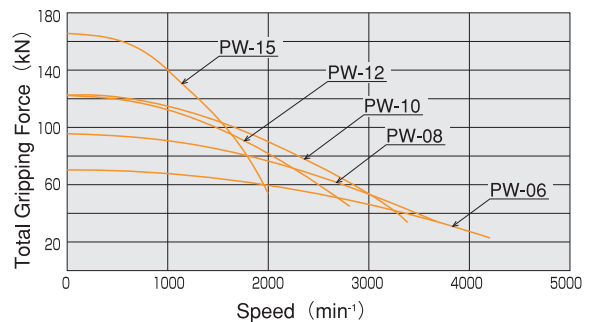

Specifications

Specs Model	Jaw Stroke (diameter)/mm	Plunger Stroke mm	Max. Draw Bar Pull Force kN(kef)	Max. Gripping Force kN(kef)	Max. Speed min ⁻¹	Net Weight with Sort top jaws kg	Moment of inertia kg · m ²	Matching Cylinder	Max. pressure MPa(kef·cm ²)	Gripping range		Compensation value for P110 only mm
										external φ mm	internal φ mm	
PW-06	7.9	11.4	23.3(2376)	70.0(7138)	4200	14.7	0.050	Y1225R	2.30(23.5)	12.7~120	70~152	1.0
PW-08	9.5	14.2	32.0(3263)	96.0(9788)	3700	23.5	0.110	Y1225R	3.09(31.5)	16~152	76~203	1.5
PW-10	12.7	17.5	41.0(4180)	123.0(12540)	3400	39.3	0.265	Y1530R	2.80(28.5)	50~203	85~235	2.0
PW-12	12.7	17.5	41.0(4180)	123.0(12540)	2800	58.3	0.523	Y1530R	2.80(28.5)	63~241	127~305	2.0
PW-15	15.8	22.4	55.0(5607)	165.0(16800)	2000	95.0	1.943	Y2035R	2.14(21.8)	76~317	165~381	3.0

Dimensional Drawing for actuated position (External Gripping)

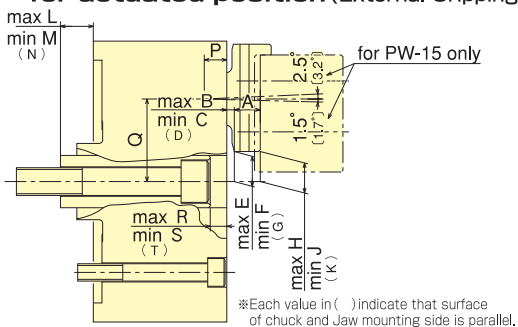

Dimensional Drawing for actuated position (Internal Gripping)

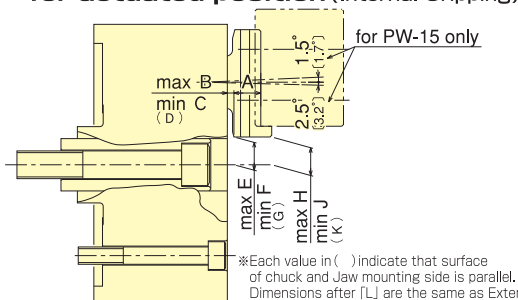

Dimensions for actuated position (External Gripping)

Dimensions Model	A	B	C	D	E	F	G	H	J	K
PW-06	15.50	5.02	3.05	3.80	20.09	18.89	19.33	20.77	18.48	19.33
PW-08	18.50	5.68	3.24	4.80	22.63	21.18	22.10	23.08	20.36	22.10
PW-10	25.61	5.47	2.44	3.53	31.16	29.44	30.03	32.37	28.77	30.03
PW-12	25.61	5.47	2.44	3.53	51.81	50.09	50.68	53.02	49.42	50.68
PW-15	28.67	6.27	2.35	3.73	75.85	73.76	74.45	77.45	72.91	74.45

Dimensions Model	L	M	N	P	Q	R	S	T
PW-06	24.0	12.6	18.95	13.20	47.63	14.60	3.20	9.55
PW-08	29.30	15.10	22.95	16.40	57.15	18.50	4.30	12.17
PW-10	34.90	17.40	27.05	19.30	71.43	19.60	2.10	11.75
PW-12	34.90	17.40	27.05	19.30	92.08	19.60	2.10	11.75
PW-15	48.70	26.30	38.40	20.07	120.65	24.90	2.50	14.60

Dimensions for actuated position (Internal Gripping)

Dimensions Model	A	B	C	D	E	F	G	H	J	K
PW-06	15.03	5.66	3.43	4.27	16.32	15.08	15.53	17.25	14.52	15.53
PW-08	16.71	8.35	5.56	6.62	18.04	16.41	17.00	18.99	15.84	17.00
PW-10	20.51	10.92	7.23	8.63	19.59	17.61	18.33	20.74	16.92	18.33
PW-12	20.51	10.92	7.23	8.63	40.24	38.26	38.98	41.39	37.57	38.98
PW-15	23.94	12.19	6.44	8.46	54.75	52.23	53.05	56.41	51.35	53.05



CHUCK

Dual Lock Chuck DL200 series

2-Way gripping

Unbelievable versatility with the ability to grip anything you want



● Increased gripping options

KITAGAWA introduce the worlds 1st chuck with two stage gripping action.

Parallel jaw clamping with secondary pull back action for work seating.

Jaws do not protrude in the Z Axis unlike conventional pull back chucks. This allows for improved gripping on difficult areas.

The gripping range is extended up the chuck OD allowing a wider range of workpieces to be machined.

DL series contributes to improve the productivity by applying flexible chucking for various operations.

● Ideal for volume production machining

Dust proof sealed body design for long life. Suitable for automation and volume production.

● Easy jaw forming

Serrated Jaws are used allowing for easy jaw forming by customer.

*CE correspondence

Gripping Example

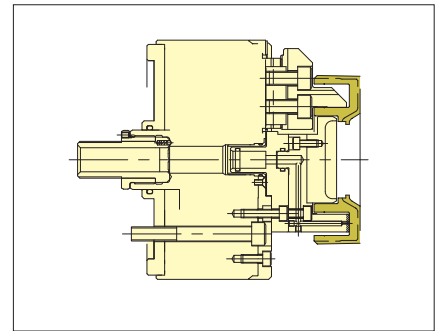

Example

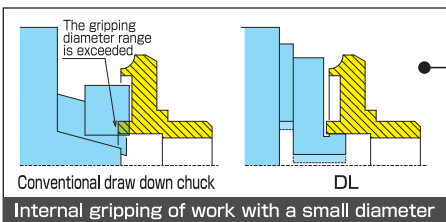
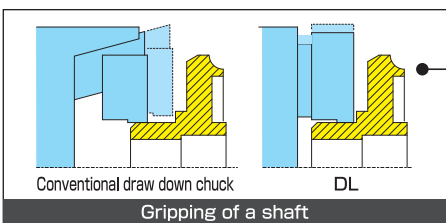
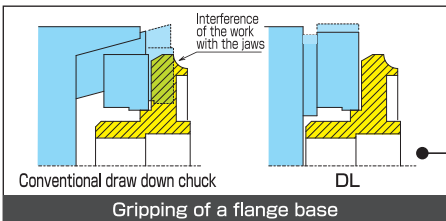

Possible gripping position
■ DL chuck
■ Conventional draw down chuck

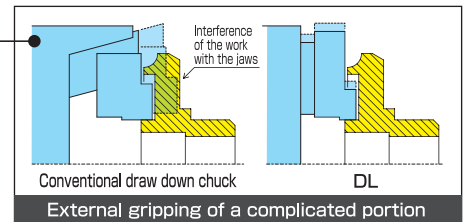
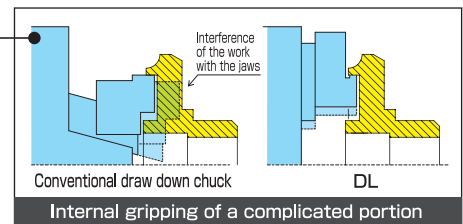
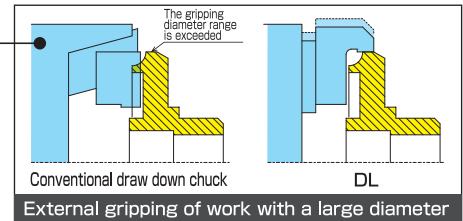

Precautions for operation

1. Attach a work to a locator before gripping.
2. Do not use the chuck with a T-nut protruded from a master jaw end face.
3. When changing the method for gripping an inner diameter of the work from an outer diameter of the work, remove a cover in order to rotate the master jaw 180-degree.
4. A work pulling quantity varies by gripping conditions such as the gripping diameter of the work, stiffness of each jaw, jaw gripping height, etc. If the work will be deformed due to over-pulling of the work or vice versa, it is necessary to adjust parts or replace them. In this case, confer with our company.

5. To obtain a stable gripping and adequate pulling of the work, set jaws low.
6. For additional machining to the chuck end face, a pin hole level is acceptable. Take care so as not to pass through the cover.
7. For locator mounting tap of DL206, use a cover mounting tap.
8. When using optional jaws for DL206 and DL210, the additional machining of jaws may be required.
9. Optional jaw of DL210 is SB12A1 of 12-inch. Take care so as not to use a wrong type of the jaw.
10. Refer to the amounts below for Jaw Stroke (one side) from the gripping position to the unclamping position.
DL206 : 0.7mm, DL208 : 0.8mm, DL210 : 1mm, DL212 : 1mm
11. Confer with our company about other unclear points.

Dimensional Drawings

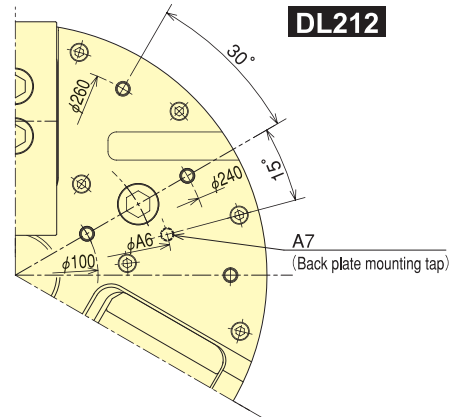
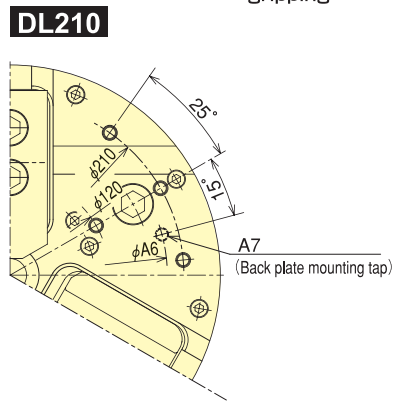
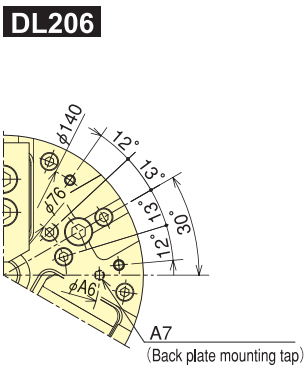
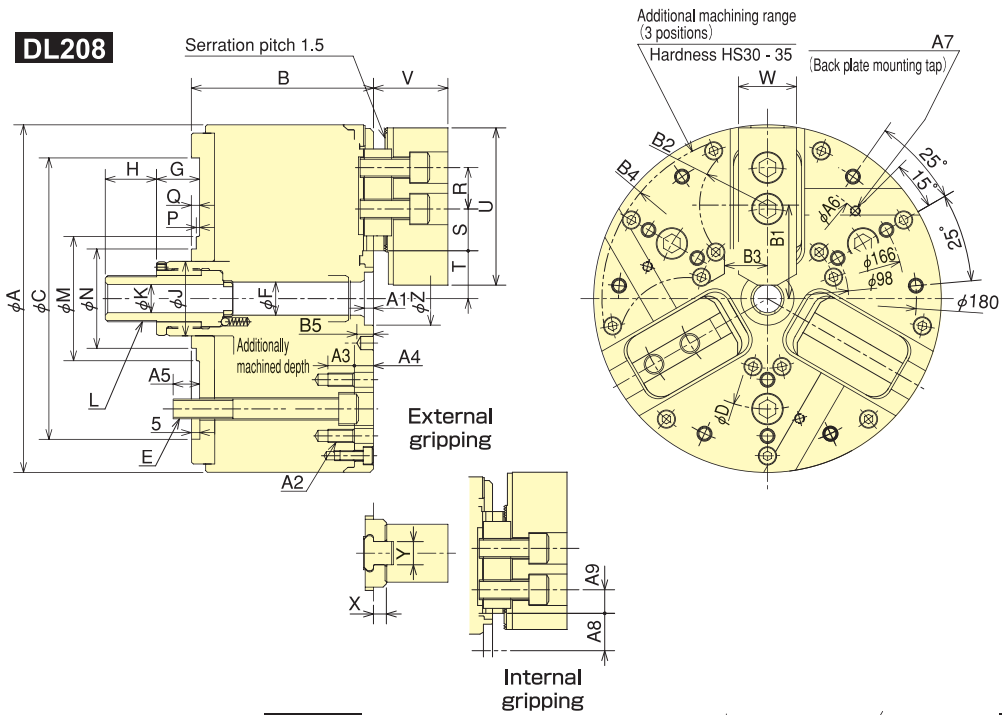

Dimensions

Model	A	B	C	D	E	F	G max.	G min.	H	J	K	L	M	N	P	Q	R	S max.	S min.	T max.	T min.
DL206	169	105	140	104.8	3-M10	20	34	22.5	30	42	17	M26×1.5	-	55	-	7	20	14.25	8.25	23.7	20.8
DL208	210	110	170	133.4	3-M12	20	37.5	26	31	45	17	M28×1.5	75	60	2	5	25	25.25	16.25	28.9	25.3
DL210	254	132	220	171.4	3-M16	20	38.5	24.5	39.5	50	17	M30×1.5	-	65	-	5	30	26.25	12.75	32.8	28.3
DL212	304	132	220	171.4	3-M16	50	33.5	19.5	44.5	75	17	M30×1.5	-	-	-	-	30	26.25	12.75	57.8	53.3

Model	U	V	W	X	Y	Z	A1	A2	A3	A4	A5	A6	A7	A8max.	A8min.	A9max.	A9min.	B1	B2	B3	B4	B5
DL206	72	41.5	31	10.3	12	32	4	3×7-M6	12	10.5	15	116	3-M6	23.7	20.8	21.25	15.25	47	R32	24	R79	MAX 9
DL208	95	45	35	7.8	14	32	5.5	3×4-M8	16	11.5	16	150	3-M6	26.2	22.6	20.25	11.25	56.5	R42	27	R100	MAX 10
DL210	101.5	59	45	14.7	18	35	5.5	3×4-M8	16	14	24	190	3-M8	29.7	25.2	35.25	21.75	68	R49	33	R120	MAX 12
DL212	129	64	50	14.7	18	50	14	3×4-M8	16	14	24	190	3-M8	54.7	50.2	35.25	21.75	93	R49	33	R145	MAX 12

Specifications

Model	Jaw stroke (diameter) mm	Plunger Stroke mm	Max. Draw Bar Pull Force kN (kgf)		Max. Gripping Force kN (kgf)		Max. Speed min ⁻¹	Net Weight with Soft top jaws kg	Moment of inertia kg·m ²
			External gripping	Internal gripping	External gripping	Internal gripping			
DL206	5.8	11.5	19.0(1937)	12.6(1285)	54.0 (5506)	36.0(3671)	6000	18.0	0.080
DL208	7.2	11.5	35.0(3569)	23.0(2345)	84.0 (8566)	56.0(5710)	5000	30.0	0.135
DL210	9.0	14	50.0(5099)	33.0(3365)	110.0(11217)	73.3(7478)	4000	52.0	0.410
DL212	9.0	14	50.0(5099)	33.0(3365)	110.0(11217)	73.3(7478)	3000	74.0	0.880

Model	Matching Cylinder	Max. pressure MPa (kgf/cm ²)		Gripping range in standard jaw of use mm	Standard jaw type	Gripping range in optional jaw of use mm	Optional jaw type	Min. input kN (kgf)	Min. pressure MPa (kgf/cm ²)
		External gripping	Internal gripping						
DL206	Y1020R	2.70 (27.5)	1.70 (17.3)	φ25~φ140	SB06D1	φ25~φ158	SB06B1	5.0 (510)	0.9 (9.2)
DL208	Y1225R	3.40 (34.7)	2.10 (21.4)	φ30~φ210	SB08B1	-	-	6.2 (632)	0.8 (8.2)
DL210	Y1530R	3.40 (34.7)	2.30 (23.5)	φ40~φ234	SB10D1	φ40~φ254	SB12A1 (Note 9)	10.0(1020)	0.9 (9.2)
DL212	Y1530R	3.40 (34.7)	2.30 (23.5)	φ90~φ304	SB12A1	-	-	10.0(1020)	0.9 (9.2)



CHUCK

Dual Lock Chuck exclusively for OD Gripping

DLN series

2 stage gripping action
The new series offers multiple gripping options to standard



- Parallel jaw gripping → Pull back action for work seating
- Seat confirmation is available without floating the work (※1)
- Draw-down amount can be controlled easily on chuck body
- Serration Jaw can be easily formed by the customer themselves

(※1) Different Rotary Cylinders from standard are required for seat confirmation

Gripping Performance

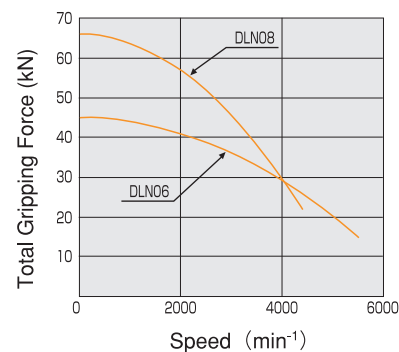

Dimensional Drawings

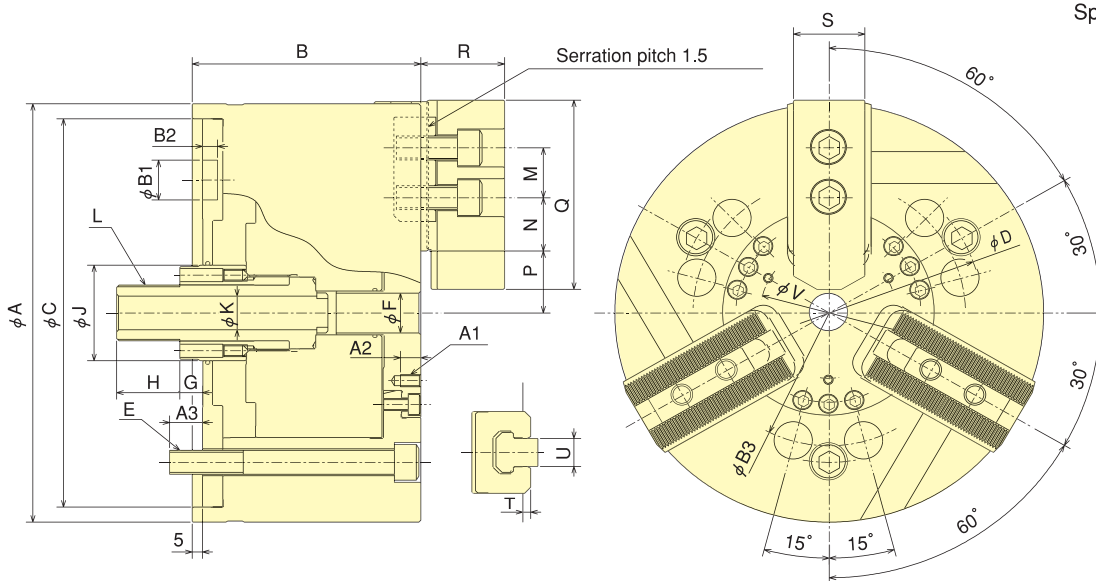

Dimensions

Dimensions Model	A	B	C	D	E	F	G max.	G min.	H	J	K	L	M	N max.	N min.
DLN06	169	105	158	126	3-M10	20	21	9	30.5	46	17	M26×1.5	20	22.75	15.25
DLN08	210	112	195	150	3-M12	20	27	11	31	48	17	M28×1.5	25	34.25	17.75

Dimensions Model	P max.	P min.	Q	R	S	T	U	V	A1	A2	A3	B1	B2	B3
DLN06	28.1	25.35	72	35	31	3.8	12	58	3-M6	10	14	17	6	104.8
DLN08	31.1	27.4	95	41	35	3.8	14	68	3-M6	10	16	20	7.5	133.4

Specifications

Specs Model	Plunger Stroke mm	Jaw Stroke (diameter) mm	Max. Draw Bar Pull Force kN(kgf)	Max. Gripping Force kN(kgf)	Max. Speed min ⁻¹	Net Weight with Soft top jaws kg	Moment of inertia kg · m ²	Dynamic Gripping Force at Max Speed	Matching Cylinder	Max. pressure MPa(kgf·cm ²)	Standard jaw type
DLN06	12	5.5	25(2550)	45(4590)	5500	18	0.07	15(1530)	Y1020R	3.5(34.3)	SB06B1
DLN08	16	7.4	35(3570)	66(6630)	4400	30	0.162	22(2210)	Y1225R	3.4(34.7)	SB08B1



CHUCK

2-Jaw Power Wing Chuck PWT(C) series

※PWC has the same specification as PW with the exception of the fact that PWC is a compensation type.

**Draw down irregular shaped materials for steady gripping
PWT(C) for gripping of square or flange castings or forgings**

- Two jaw type for gripping irregular workpieces
Draw down action ensures secure gripping of workpiece onto a reference surface.
- Compatible with PW series and soft jaws
*CE correspondence

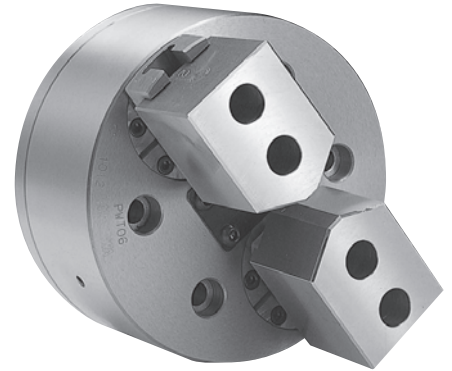

Advanced Chuck

Dimensional Drawings

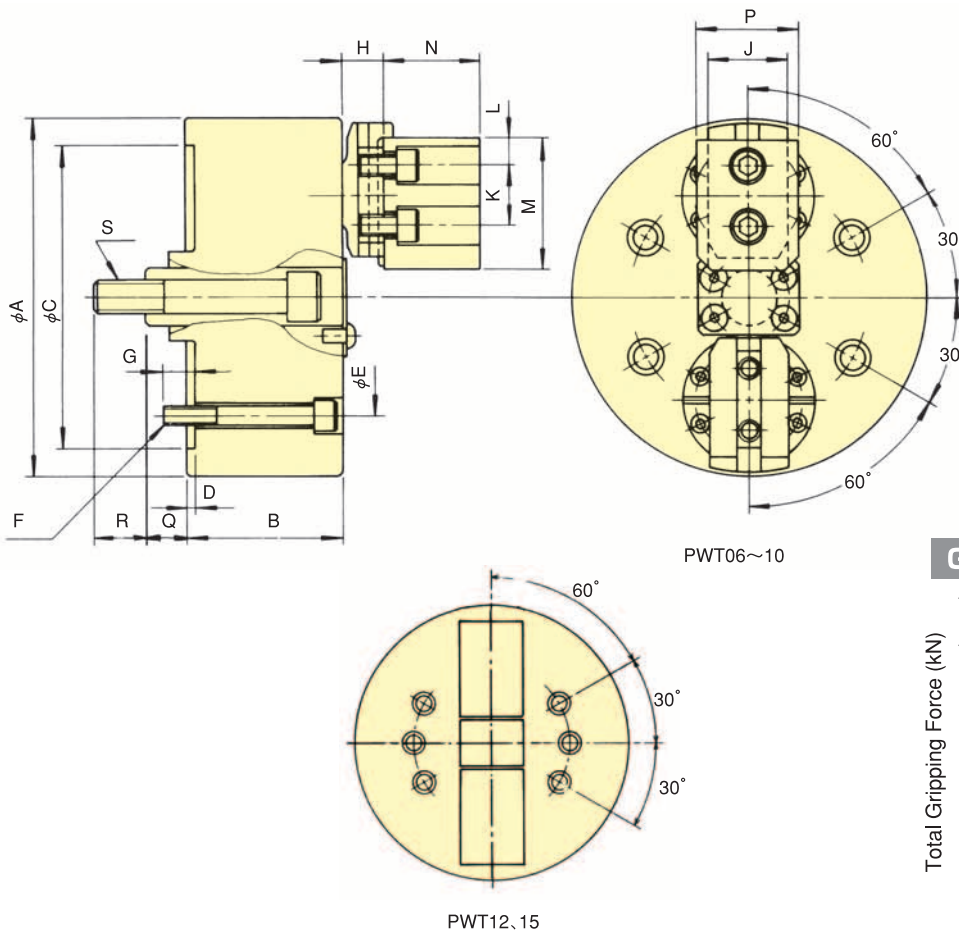

Gripping Performance

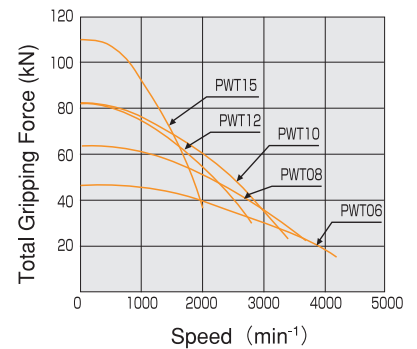

Dimensions

Model	A	B	C(H6)	D	E	F	G	H	J	K	L	M	N	P	Q _{max}	Q _{min}	R	S
PWT06	162	77	140	5	104.8	4-M10	14	19.3	38.07	29.36	15	67.5	47.7	50.8	24	12.6	25.4	M16
PWT08	200	88	170	5	133.4	4-M12	18	23.33	44.45	34.14	15	74	54.17	57	29.3	15.1	29.2	M18
PWT10	254	105	220	5	171.4	4-M16	25	29.14	57.1	44.45	19	89.5	66.9	70.1	34.9	17.4	34.7	M22
PWT12	300	105	220	5	171.4	6-M16	25	29.14	57.1	44.45	19	108.5	66.9	70.1	34.9	17.4	34.7	M22
PWT15	381	117	300	5	235	6-M20	30	32.4	66.62	53.98	23.9	140	73.2	76.2	48.7	26.3	41	M27

Specifications

Model	Jaw Stroke (diameter) mm	Plunger Stroke mm	Max. Draw Bar Pull Force kN(kgf)	Max. Gripping Force kN(kgf)	Max. Speed min⁻¹	Net Weight with Soft top jaws kg	Moment of inertia kg·m²	Matching Cylinder	Max. pressure MPa(kgf·cm²)	Gripping range	
										external φ mm	internal φ mm
PWT06	7.9	11.4	15.5(1581)	46.6 (4752)	4200	14.0	0.047	Y1225R	1.60(16.3)	12.7~120	70~152
PWT08	9.5	14.2	21.3(2172)	64.0 (6526)	3700	24.0	0.120	Y1225R	2.10(21.4)	16~152	76~203
PWT10	12.7	17.5	27.3(2784)	82.0 (8362)	3400	46.0	0.378	Y1530R	1.85(18.9)	50~203	85~235
PWT12	12.7	17.5	27.3(2784)	82.0 (8362)	2800	63.0	0.720	Y1530R	1.82(18.6)	63~241	127~305
PWT15	15.8	22.4	36.7(3742)	110.0(11217)	2000	112.0	2.130	Y2035R	1.40(14.3)	76~317	165~381



CHUCK

Open Centre Pull Lock Chuck PUB series

Draw down for high-precision processing
Open Centre type accommodates shaft processing

* CE correspondence

Work Examples

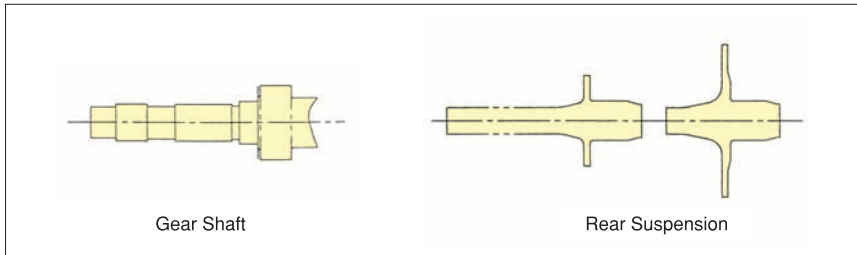

Gripping Examples

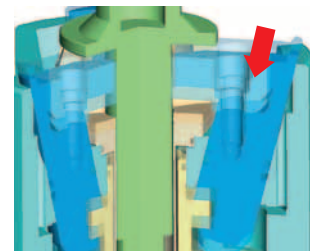
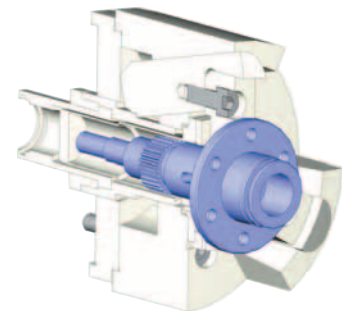
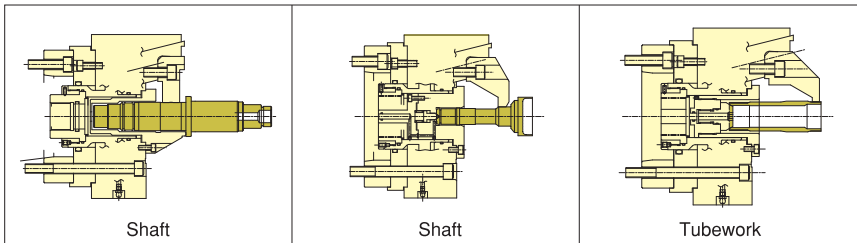

Dimensional Drawings

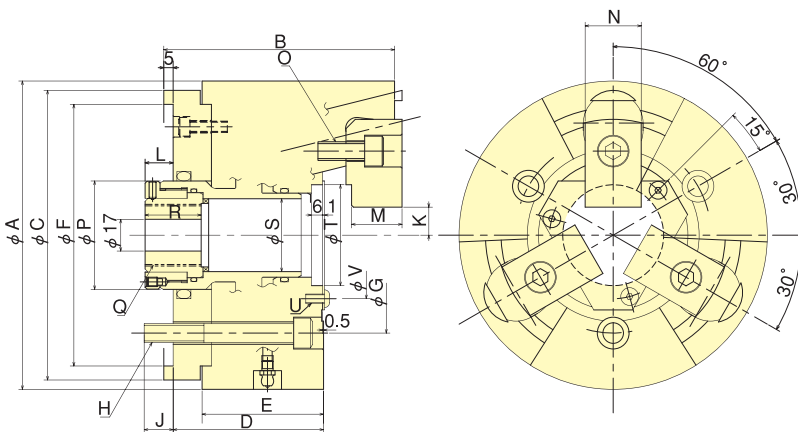

Gripping Performance

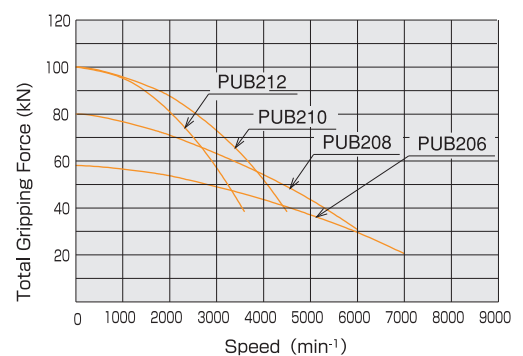

Dimensions

Dimensions	A	B	C	D	E	F (G7)	G	H	J	K max.	K min.	L max.	L min.	M	N	O	P	Q max.	R	S	T (H6)	U	V
PUB206	165	123.5	155	80.5	65	140	104.8	3-M10	15.5	16.25	13.75	20	10	27	30	3-M10	58	M33x1.5	30	39	54	3-M5	68
PUB208	210	143	180	93	70	170	133.4	3-M12	17	16.25	13.75	20	10	31	35	3-M12	79	M45x2.0	29.5	50	66	3-M6	80
PUB210	254	158	230	103	82	220	171.4	3-M16	23	21.25	18.75	24	14	35	40	3-M14	102	M65x2.0	35.5	72	90	3-M8	104
PUB212	304	163	240	103	82	220	171.4	3-M16	25	46.25	43.75	19	9	40	40	3-M14	135	M92x2.0	35.5	100	114	3-M10	130

Specifications

Specs	Gripping range		Jaw Stroke (diameter)mm	Plunger Stroke mm	Max. Draw Bar Pull Force kN(kgf)	Max. Gripping Force kN(kgf)	Max. Speed min⁻¹	Net Weight with Soft top jaws kg	Moment of inertia kg · m²	Matching Cylinder	Max. pressure MPa(kgf/cm²)	Max. Through Hole in Seat confirmation Specification mm
Model	Max. mm	Min. mm										
PUB206	100	25	5	10	18.0(1835)	58.0(5914)	7000	14.4	0.053	Y1020R	2.55(26.0)	φ29
PUB208	130	25	5	10	25.0(2549)	80.0(8158)	6000	25.3	0.140	Y1225R	2.50(25.5)	φ41
PUB210	160	35	5	10	35.0(3569)	100.0(10197)	4500	43.5	0.355	Y1225R	3.35(34.2)	φ61
PUB212	210	85	5	10	35.0(3569)	100.0(10197)	3600	60.5	0.675	Y1225R	3.35(34.2)	φ87



CHUCK

Pull Lock Chuck PU series

Pull back chuck for external gripping



- **High gripping stability means heavy cutting is possible**
Radial gripping forces and strong pull back action allow stable heavy cutting.
- **Excellent repeatability!**
Side and rear support provided by the base jaws reduces the centrifugal gripping force loss thus resulting in high repeatability.
- **Long-term stable accuracy!**
The sophisticated mechanism and special steel design ensure longevity and gripping accuracy.
- **Compatible with automation by use of seating confirmation**
*CE correspondence

Dimensional Drawings

*PU203:3.5
PU204 & PU205:4

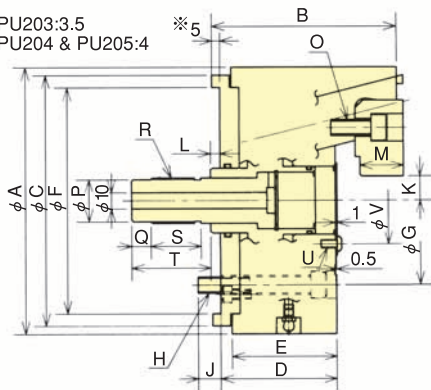

Work Examples

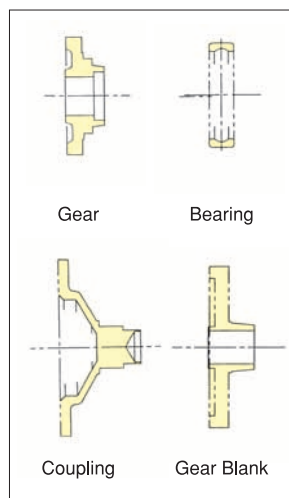

Gripping Examples

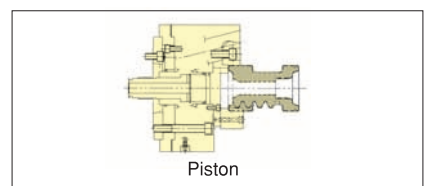

Gripping Performance

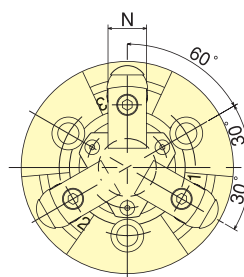
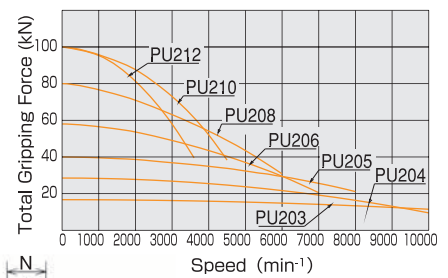

PU203~PU205

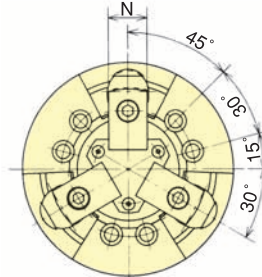

PU206~PU212

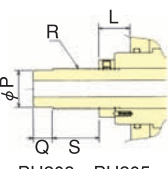

PU203~PU205
(Drawbar connection)

Dimensions

Model	A	B	C	D	E	F (G7)	G	H	J	K max.	K min.	L max.	L min.	M	N	O	P	Q	R	S	T	U	V
PU203	75	54.5	75	38.5	34	69	54	3-M6	9	2.5	1.5	21.5	17.5	9	15	3-M5	8	10	M10	19	-	3-M3	25.5
PU204	110	72.5	100	51	43	85	70.6	3-M10	12	10.75	9.25	19	13	14	20	3-M6	18	12	M20x1.5	24	-	3-M4	42
PU205	135	84.5	135	59	51	110	82.6	3-M10	15	13.25	11.75	23	17	17	24	3-M8	23	12	M25x1.5	30	-	3-M5	52
PU206	165	115	155	72	65	140	104.8	6-M10	14	16.25	13.75	11	1	27	30	3-M10	26	12	M28x1.5	31	49	3-M5	54
PU208	210	135	180	85	70	170	133.4	6-M12	15	16.25	13.75	11	1	31	35	3-M12	32	15	M35x1.5	30	51	3-M6	65
PU210	254	150	230	95	82	220	171.4	6-M16	23	21.25	18.75	12	2	35	40	3-M14	35	15	M38x1.5	30	51	3-M8	80
PU212	304	155	240	95	82	220	171.4	6-M16	23	46.25	43.75	12	2	40	40	3-M14	42	15	M45x1.5	30	51	3-M10	100

Specifications

Model	Gripping range		Jaw Stroke (diameter)mm	Plunger Stroke mm	Max. Draw Bar Pull Force kN(kgf)	Max. Gripping Force kN(kgf)	Max. Speed min⁻¹	Net Weight with Soft top jaws kg	Moment of inertia kg·m²	Matching Cylinder	Max. pressure MPa(kgf/cm²)
	Max. mm	Min. mm									
PU203	32	4	2	4	5.8 (590)	16.7 (1700)	10000	1.5	0.0012	YG-329	1.63 (16.6)
PU204	60	10	3	6	10.0 (1020)	28.5 (2906)	8000	3.8	0.006	F0933H	2.06 (21.0)
							10000			Y1225R	1.18 (12.0)
PU205	84	15	3	6	14.0 (1428)	40.0 (4079)	8000	6.6	0.017	F0933H	2.50 (25.5)
PU206	100	25	5	10	18.0 (1835)	58.0 (5914)	7000	14.1	0.050	Y1020R	2.55 (26.0)
PU208	130	25	5	10	25.0 (2549)	80.0 (8158)	6000	24.0	0.133	Y1225R	2.50 (25.5)
PU210	160	35	5	10	35.0 (3569)	100.0 (10197)	4500	42.0	0.338	Y1225R	3.35 (34.2)
PU212	210	85	5	10	35.0 (3569)	100.0 (10197)	3600	60.5	0.655	Y1225R	3.35 (34.2)



CHUCK

Pull Lock Chuck PUE series

Pull back chuck for internal gripping

*CE correspondence



Work Examples

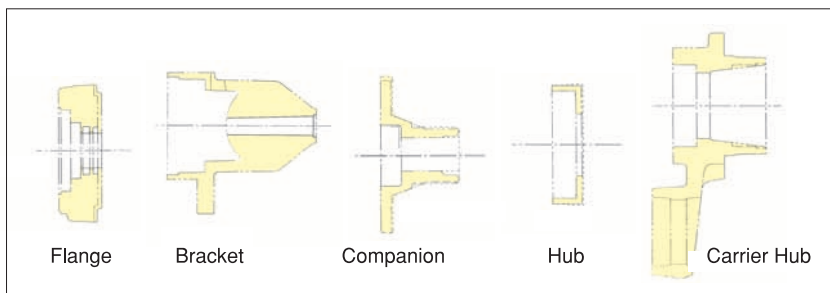

Gripping Performance

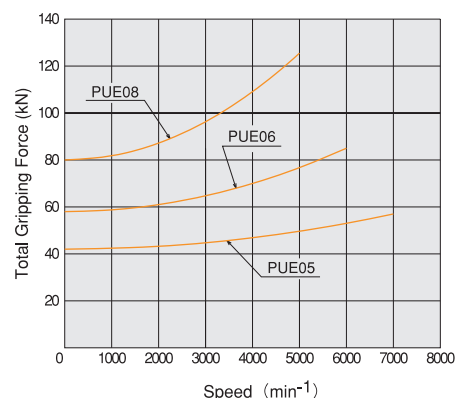

Gripping Examples

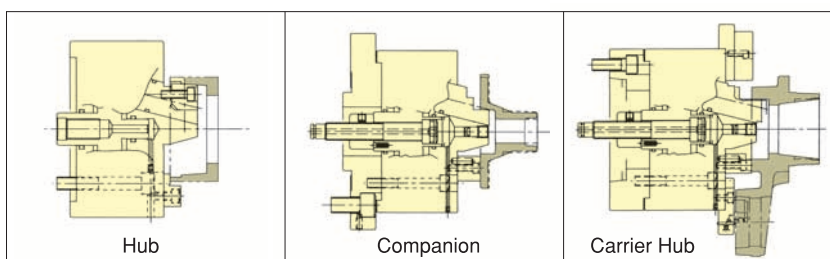

Dimensional Drawings

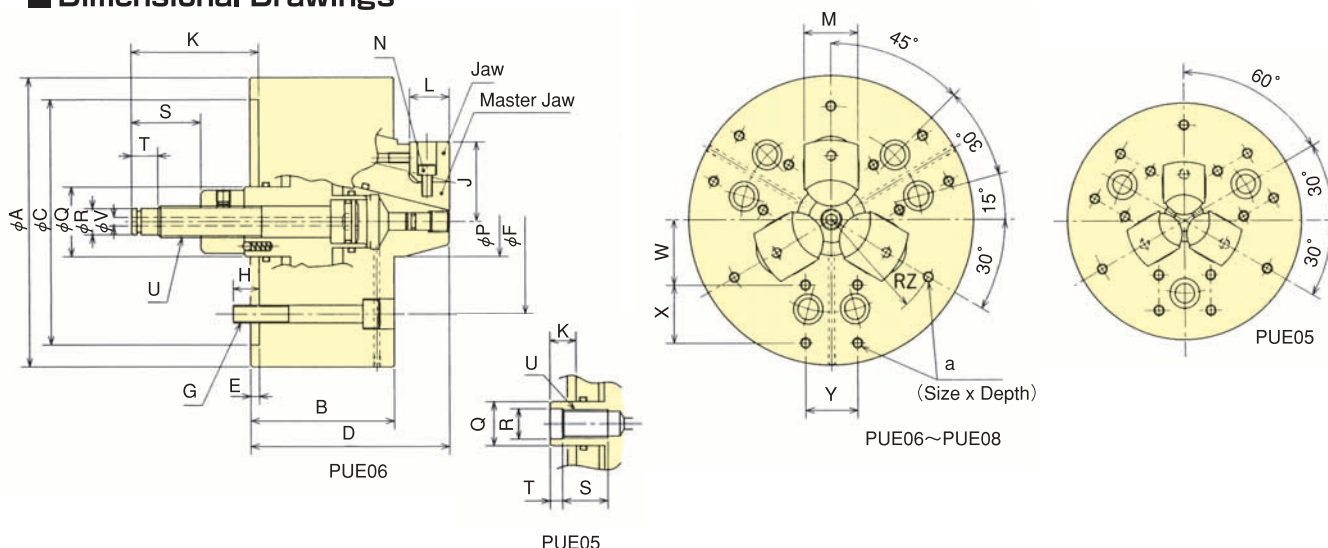

Dimensions

Model	A	B	C(G7)	D	E	F	G	H	J max.	J min.	K max.	K min.	L	M	N	P	Q	R	S	T	U	V	W	X	Y	Z	a
PUE05	135	72	110	98	5	82.55	3-M10	15	34.4	33	18	12	20	24	3-M6	24	25	17 ^{±0.1}	26	7	M16x2	—	31	20	30	55	M6x11
PUE06	165	83	140	115	5	104.8	6-M10	15	46.9	44.5	78.5	68.5	23	31	3-M6	40	40	15h8	40	15	M18x2.5	5	37	33	30	65	M6x11
PUE08	210	94	170	139	5	133.4	6-M12	17	57.2	54.8	91.5	81.5	23	35	3-M6	49	40	15h8	47.5	15	M20	5	45	40	30	80	M6x11

Specifications ※When using PUE-05 at more than 6000 rpm, a special cylinder is required.

Model	Jaw Stroke (diameter)/mm	Plunger Stroke mm	Max. Draw Bar Pull Force kN(kgf)	Max. Gripping Force kN(kgf)	Max. Speed min ⁻¹	Net Weight with Soft top jaws kg · m ²	Moment of inertia kg · m ²	Matching Cylinder	Max. pressure MPa(kgf·cm ²)	Gripping range		
										Standard jaws	Option jaws	Master jaws
PUE05	2.8	6	13.0(1325)	42.0(4280)	7000	7.6	0.018	Y1020R [※]	1.90(19.5)	φ50~φ65	φ65~φ80	φ29~φ50
PUE06	4.8	10	18.0(1835)	58.0(5914)	6000	13.9	0.043	Y1020R	2.50(25.5)	φ70~φ89	φ89~φ105	φ44~φ70
PUE08	4.8	10	24.8(2529)	80.0(8158)	5000	26.8	0.144	Y1020R	3.40(34.5)	φ90~φ110	φ110~φ150	φ50~φ90



CHUCK

Level Lock Chuck

LU series

Economical pull back chuck

- Suitable for gripping castings and forgings with draft angle
- Long Jaw Stroke
- Stable gripping accuracy



Gripping Examples

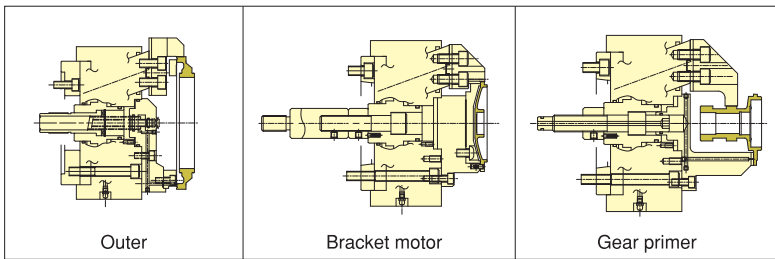

Gripping Performance

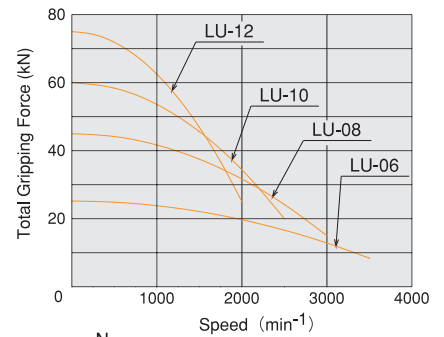

Advanced Chuck

Dimensional Drawings

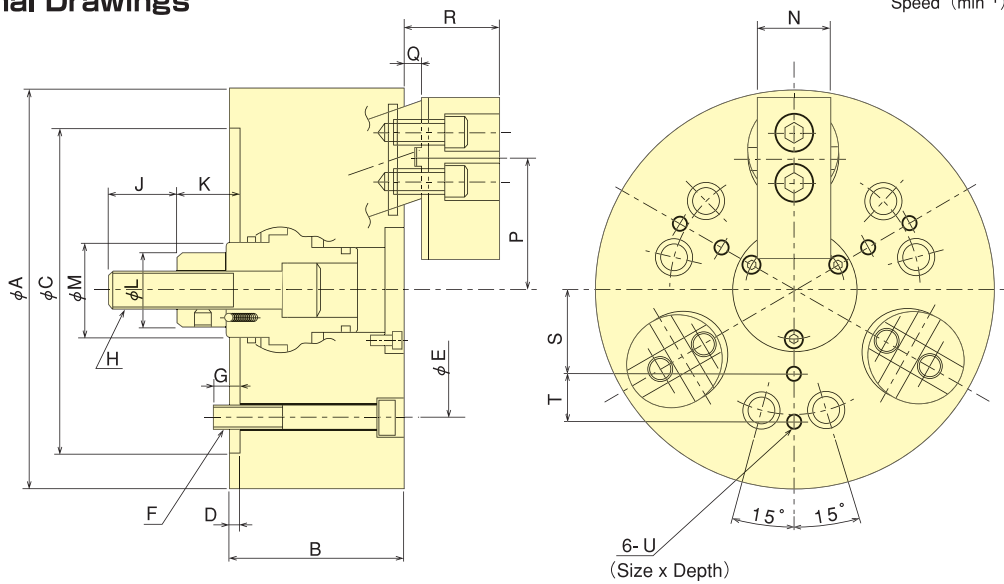

Dimensions

Model	Dimensions		C	D	E	F	G	H	J	K (max.)	K (min.)	L	M	N	P (max.)	P (min.)	Q (max.)	Q (min.)	R (max.)	R (min.)	S	T	U
	A	B																					
LU-06	165	80	140	5	104.8	6-M10	16	M16x2.0	36	33	23	32	35	35	58.0	54.4	14	4	45	35	35	20	M6x12
LU-08	210	90	170	5	133.4	6-M12	15	M20x2.5	36	38	28	38	50	40	70.8	67.2	15	5	56	46	45	25	M8x15
LU-10	254	110	220	5	171.4	6-M16	24	M24x3.0	46	47	32	50	60	50	85.0	79.6	19	4	65	50	55	30	M8x15
LU-12	304	125	220	5	171.4	6-M16	24	M27x3.0	50	47	32	50	60	60	102.0	96.6	19	4	70	55	70	35	M10x17

Specifications

Model	Specs	Jaw Stroke (diameter) mm	Plunger Stroke mm	Max. Draw Bar Pull Force kN(kgf)	Max. Gripping Force kN(kgf)	Max. Speed min ⁻¹	Net Weight kg	Moment of inertia kg · m ²	Matching Cylinder	Max. pressure MPa(kgf/cm ²)	Gripping range mm
LU-06		7.2	10	15.0 (1530)	25.2 (2570)	3500	13.7	0.045	Y1020R	2.15 (21.9)	35~165
LU-08		7.2	10	25.0 (2549)	45.0 (4589)	3000	26.0	0.143	Y1225R	2.50 (25.5)	40~210
LU-10		10.8	15	35.0 (3569)	60.0 (6118)	2500	45.5	0.373	Y1225R	3.30 (34.0)	50~254
LU-12		10.8	15	45.0 (4589)	75.0 (7648)	2000	68.0	0.800	Y1530R	3.00 (30.6)	50~304



CHUCK

Finger Chuck FG series

Face clamping chuck, ideal for thin walled workpieces

- Distortion is reduced by using face clamping on thin section parts
 - Using the aluminium rear body allows for high speed rotation, thus saving machining time
 - Jaws include equalising mechanism to securely grip parts with variable thickness (Equalization amount/2.5 mm max)
 - Through hole allows pneumatic accessories
- * CE correspondence



Dimensional Drawings

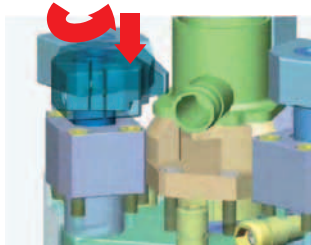
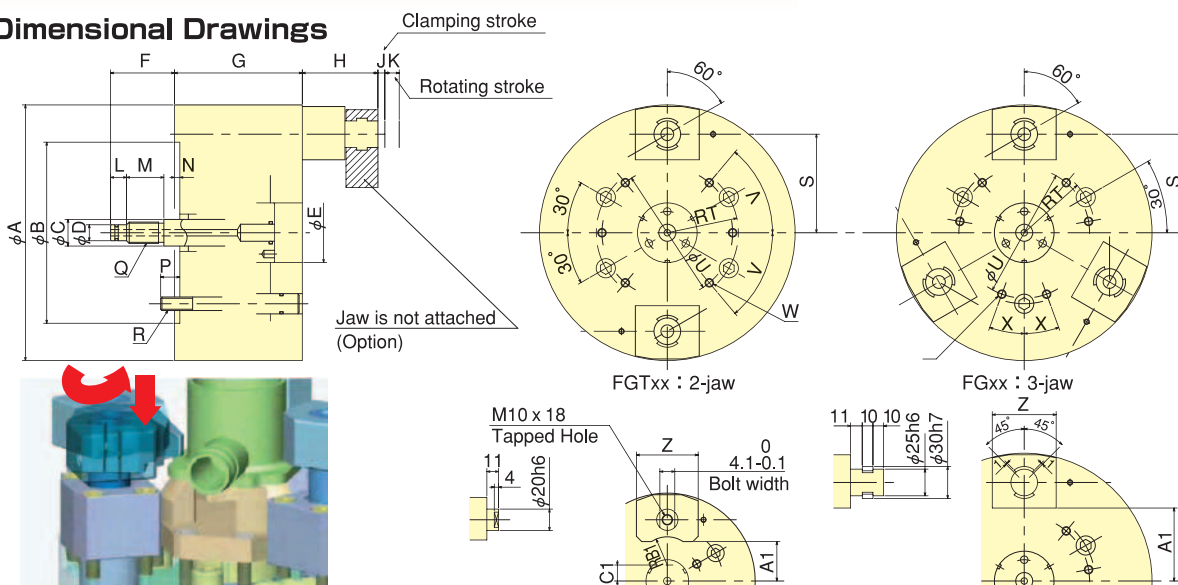

05", 06" jaw mounting part dimensions (Jaw's shaft)

08", 10", 12" jaw mounting part dimensions (Jaw's shaft)

Dimensions *FGT : 2-jaw, FG : 3-jaw

Model	A	B	C	D	E	F	G	H	J	K	L	M	N	P	Q	R	S	T	U	V	W	X	Y	Z	A1	B1	C1
FGT05/FG05	135	110	14	9	37	50-70	110	36-56	8	12	15	30	5	14	M12	M10	42.5	41.3	50	30°	4-M6 screw depth 12	-	3-M6 screw depth 12	58	22	26.5	-
FGT06/FG06	165	140	16	12	40	50-70	110	36-56	8	12	15	30	5	14	M16	M10	57.5	52.4	64	30°	4-M8 screw depth 15	-	3-M8 screw depth 15	58	37	26.5	15
FGT08/FG08	210	170	25	16	56	50-70	120	71-91	8	12	15	30	5	18	M20	M12	77.5	66.7	104	50°	6-M8 screw depth 15	20°	6-M8 screw depth 15	60	53.5	-	-
FGT10/FG10	254	220	25	16	56	50-70	120	71-91	8	12	15	30	5	24	M20	M16	99.5	85.7	140	50°	6-M8 screw depth 15	20°	6-M8 screw depth 15	60	75.5	-	-
FGT12/FG12	304	220	25	16	56	50-70	120	71-91	8	12	15	30	5	24	M20	M16	124.5	85.7	190	50°	6-M8 screw depth 15	20°	6-M8 screw depth 15	60	100.5	-	-

Specifications *FGT : 2-jaw, FG : 3-jaw *1-Jaw length : 30mm *2-Jaw length : 40mm

Model	Max. Draw Bar Pull Force kN(kgf)	Max. Speed min ⁻¹	Net Weight kg	Moment of inertia kg · m ²	Matching Cylinder	Clamping stroke mm	Gripping force / jaw kN(kgf)	Max. Gripping dia. mm	Limit height by optional jaw	Equalizing q'ty mm	Cylinder with seating
FGT05 / FG05	5.0 (510) / 7.5 (765)	4000	10.0 / 12.0	0.025 / 0.030	Y1020R	8	2.0(204)*1	52	41	1	Y1020RE09C
FGT06 / FG06	6.0 (612) / 9.0 (918)	4000	11.0 / 13.0	0.045 / 0.050	Y1020R	8	2.5(255)*1	78	41	1.5	Y1020RE09C
FGT08 / FG08	12.0(1224) / 18.0(1835)	3500	22.0 / 24.0	0.130 / 0.140	Y1020R	8	5.5(561)*2	105	61	2	Y1020RE09C
FGT10 / FG10	12.0(1224) / 18.0(1835)	3500	34.0 / 36.0	0.290 / 0.310	Y1020R	8	5.5(561)*2	150	61	2	Y1020RE09C
FGT12 / FG12	12.0(1224) / 18.0(1835)	3000	46.0 / 48.0	0.570 / 0.590	Y1020R	8	5.5(561)*2	200	61	2.5	Y1020RE09C

Dimensional Drawings for Blank Jaws (Option)

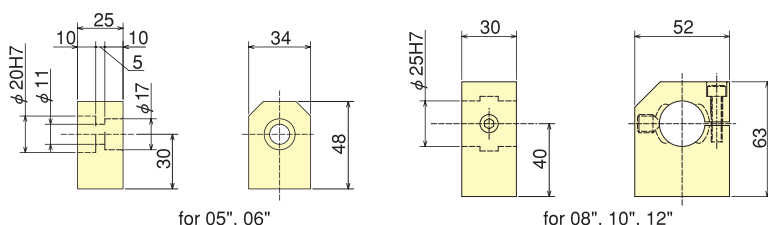

Gripping Examples

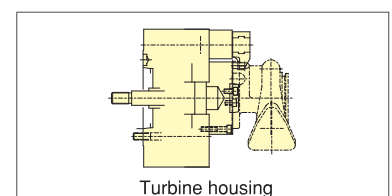



CHUCK

Finger Chuck for Automotive Wheels

FG-V series

Rigid body
Finger Chuck for aluminium wheel
machining for automobiles



Advanced Chuck

Gripping Examples

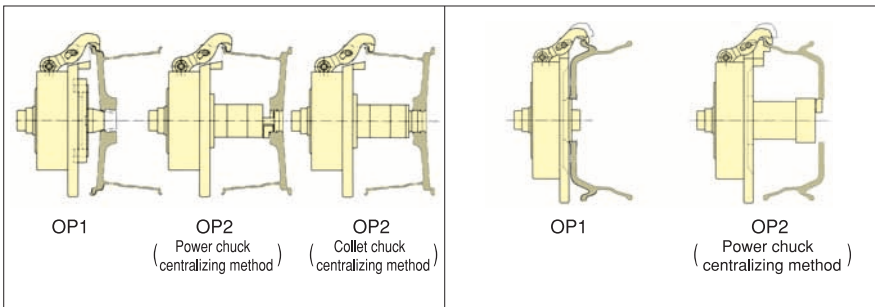

Dimensional Drawings

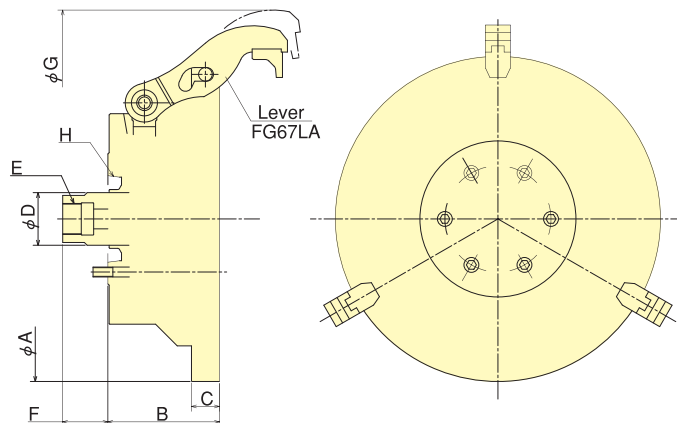

Dimensions

Model	A	B	C	D	E	F _{max.}	F _{min.}	G	H
FG50V	525	180	45	85	M50×1.5	73	38	675	A2-8
FG56V	575	180	45	85	M50×1.5	73	38	725	A2-11
FG62V	625	180	45	85	M50×1.5	73	38	775	A2-11

Specifications

Model	Specs	Max. Draw Bar Pull Force kN(kgf)	Max. Speed min ⁻¹	Net Weight kg	Moment of inertia kg · m ²	Open jaw stroke/Clamping stroke mm	Gripping force/jaw kN(kgf)
FG50V		30.0 (3059)	2500	135.0	3.750	18.5/16.5	9.5 (969)
FG56V		30.0 (3059)	2500	190.0	5.800	18.5/16.5	9.5 (969)
FG62V		30.0 (3059)	2500	220.0	8.800	18.5/16.5	9.5 (969)

Measurement table for Wheel

Model	12"	13"	14"	15"	16"	17"	18"	19"	20"	21.5"	22.5"
FG50V		○	○	○	○	○	○				
FG56V		○	○	○	○	○	○	○	○		
FG62V					○	○	○	○	○	○	○



CHUCK

Finger Chuck for Automotive Wheels

FG-L series

Standard Finger Chuck

Light-Weight body for aluminium wheel machining for automobiles

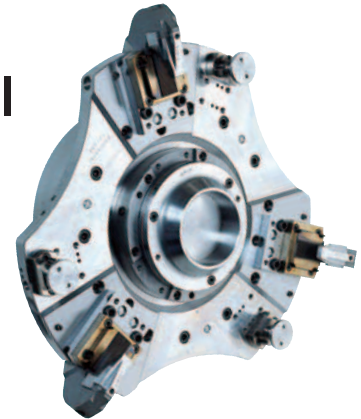

● High Speed

A technological breakthrough in the design has allowed a max speed of 3000 min⁻¹ for each wheel size (13"-18").

Gripping Examples

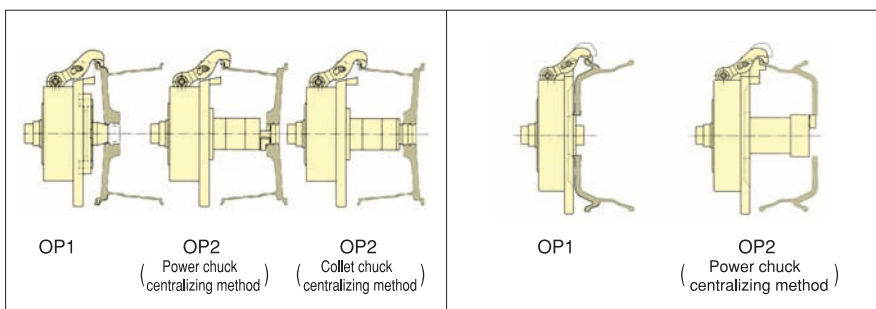

Advanced Chuck

■ Dimensional Drawings

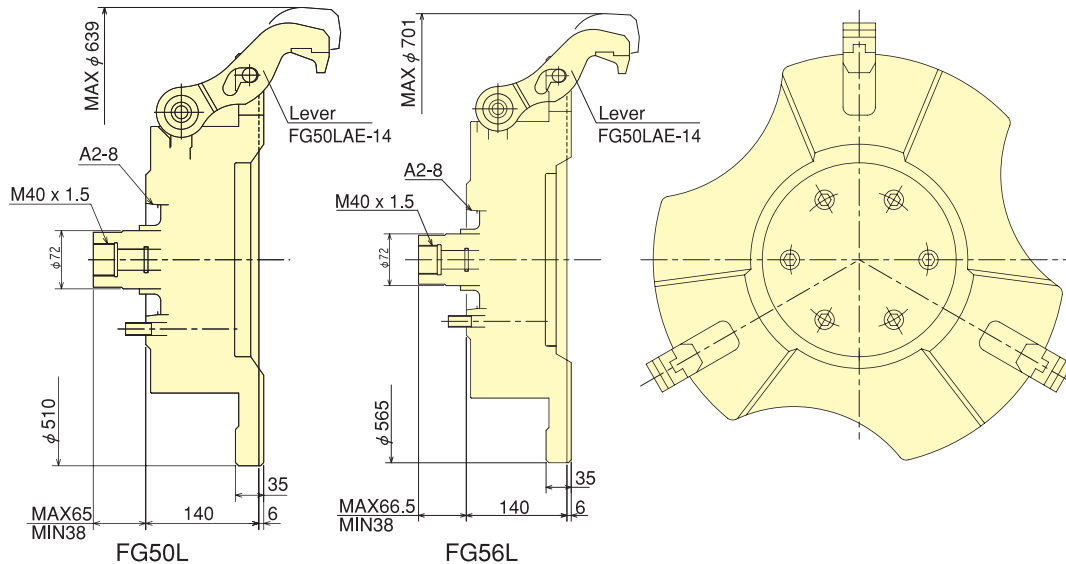

■ Dimensions

Model	Specs	Max. Draw Bar Pull Force kN(kgf)	Max. Speed min ⁻¹	Net Weight kg	Moment of inertia kg · m ²	Open jaw stroke/Clamping stroke mm	Gripping force/jaw kN(kgf)
FG50L		30.0 (3059)	3000	97.0	2.350	17/10	9.5 (969)
FG56L		30.0 (3059)	2500	116.0	3.320	18.5/10	9.5 (969)

■ Measurement Table for Wheel

Model	Wheel size	12"	13"	14"	15"	16"	17"	18"	19"	20"	21.5"	22.5"
FG50L			○	○	○	○	○	○				
FG56L			○	○	○	○	○	○	○	○		



CHUCK

6-Jaw Finger Chuck for Motorcycle Wheels FG-M series

Finger Chuck ideally suited for aluminium wheel machining for motorcycles

● High Stability

The floating mechanism ensures firm chucking.

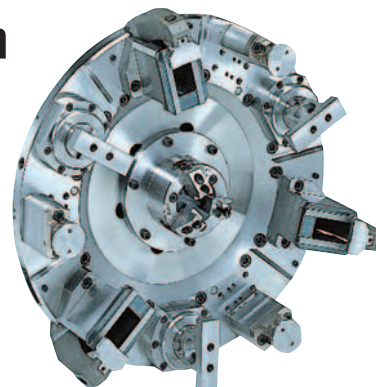

Advanced Chuck

Gripping Examples

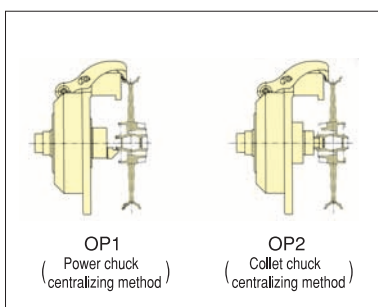

Dimensional Drawings

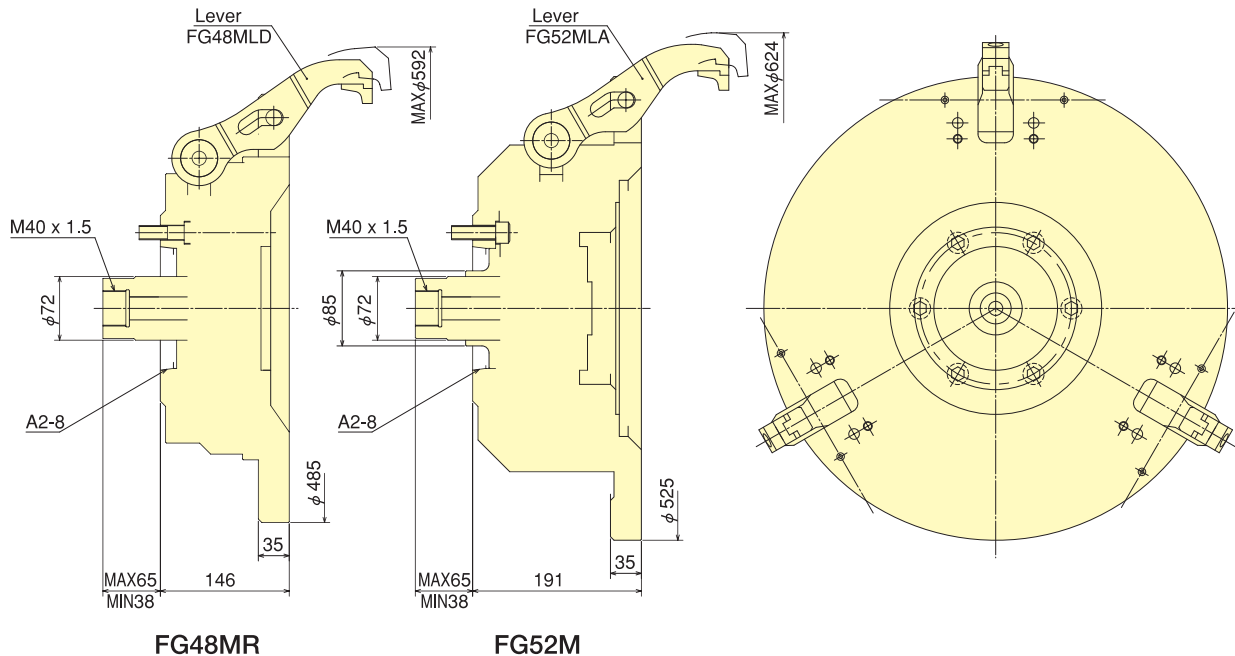

Dimensions

Model	Specs	Max. Draw Bar Pull Force kN(kgf)	Max. Speed min ⁻¹	Net Weight kg	Moment of inertia kg · m ²	Open jaw stroke/Clamping stroke mm	Gripping force/jaw kN(kgf)
FG48MR		12.0 (1224)	2500	91.0	1.780	14/13	3.5 (357)
FG52M		21.0 (2141)	2500	130.0	3.650	14/13	6.5 (663)

Measurement table for Wheel

Model	Wheel size	12"	13"	14"	15"	16"	17"	18"	19"	20"	21.5"	22.5"
FG48MR		○	○	○	○	○	○	○	○			
FG52M		○	○	○	○	○	○	○	○			



CHUCK

Easy Preparation Finger Chuck FG-Q series

Quick setup for size changes
Finger Chuck ideally suited for aluminium wheel machining for automobiles

- Easy preparation for each size of Wheel
 - The setup time is approximately 30 seconds
- Due to the preparation for each size, three levers and fixed jigs are moved simultaneously simply by rotating the handle, thus saving the setup time.

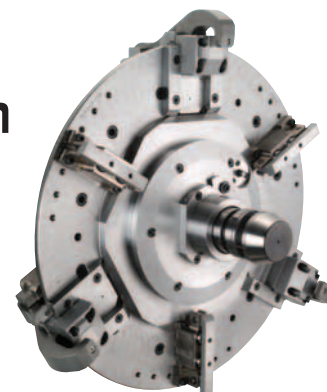

Dimensional Drawings

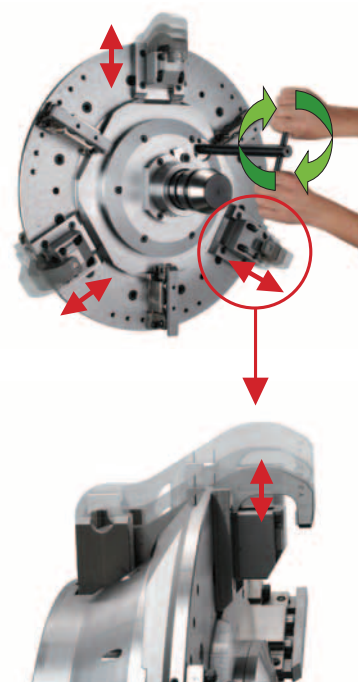
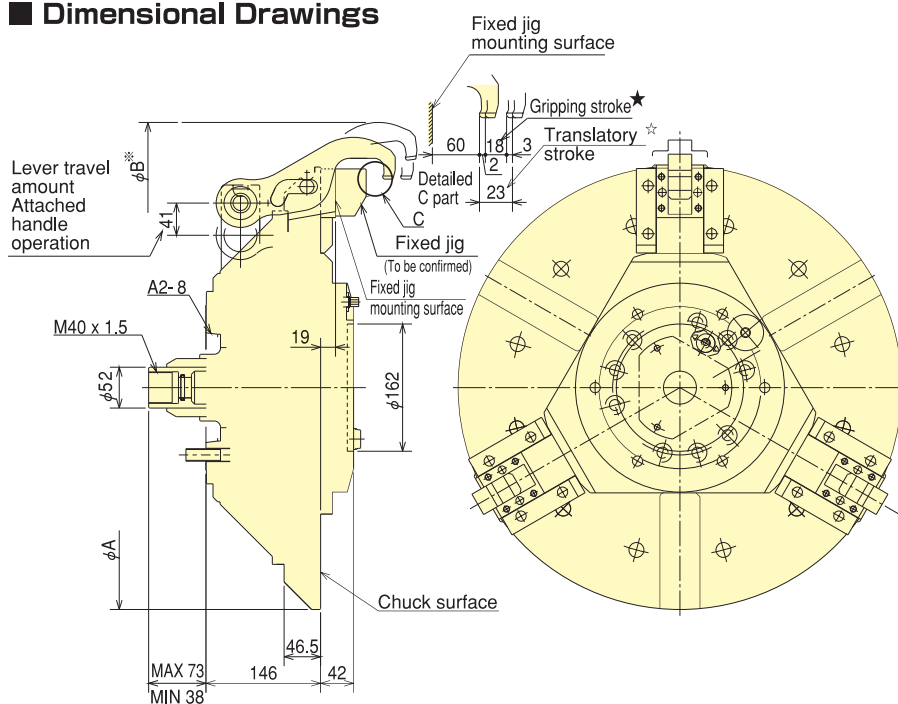

Dimensions

*B shows the state in use of the lever A.

Dimensions	A	B*
Model		
FG56Q	565	672
FG62Q	620	727

Specifications

Specs	Jaw Stroke			Max. Draw Bar Pull Force kN(kgf)	Max. Speed min ⁻¹	Net Weight kg	Moment of inertia kg·m ²	Gripping force/jaw kN(kgf)
	Full Stroke mm	Translatory/ Gripping* Stroke mm	Open jaw Stroke mm					
Model								
FG56Q	35	23/18	12	30.0 (3059)	2500	117.5	4.130	9.5 (969)
FG62Q					2200	195.0	7.500	

Measurement table for Wheel

Model	Wheel size Lever	13	14	15	16	17	18	19	20	21	22
		FG56Q	A					○	○	○	○
	C	○	○	○	○						
	B(option)			○	○	○	○				
FG62Q	A							○	○	○	○
	C			○	○	○	○				
	B(option)					○	○	○	○		