

BEST GmbH

Modular clamping technology and automation

Stationary clamping technology

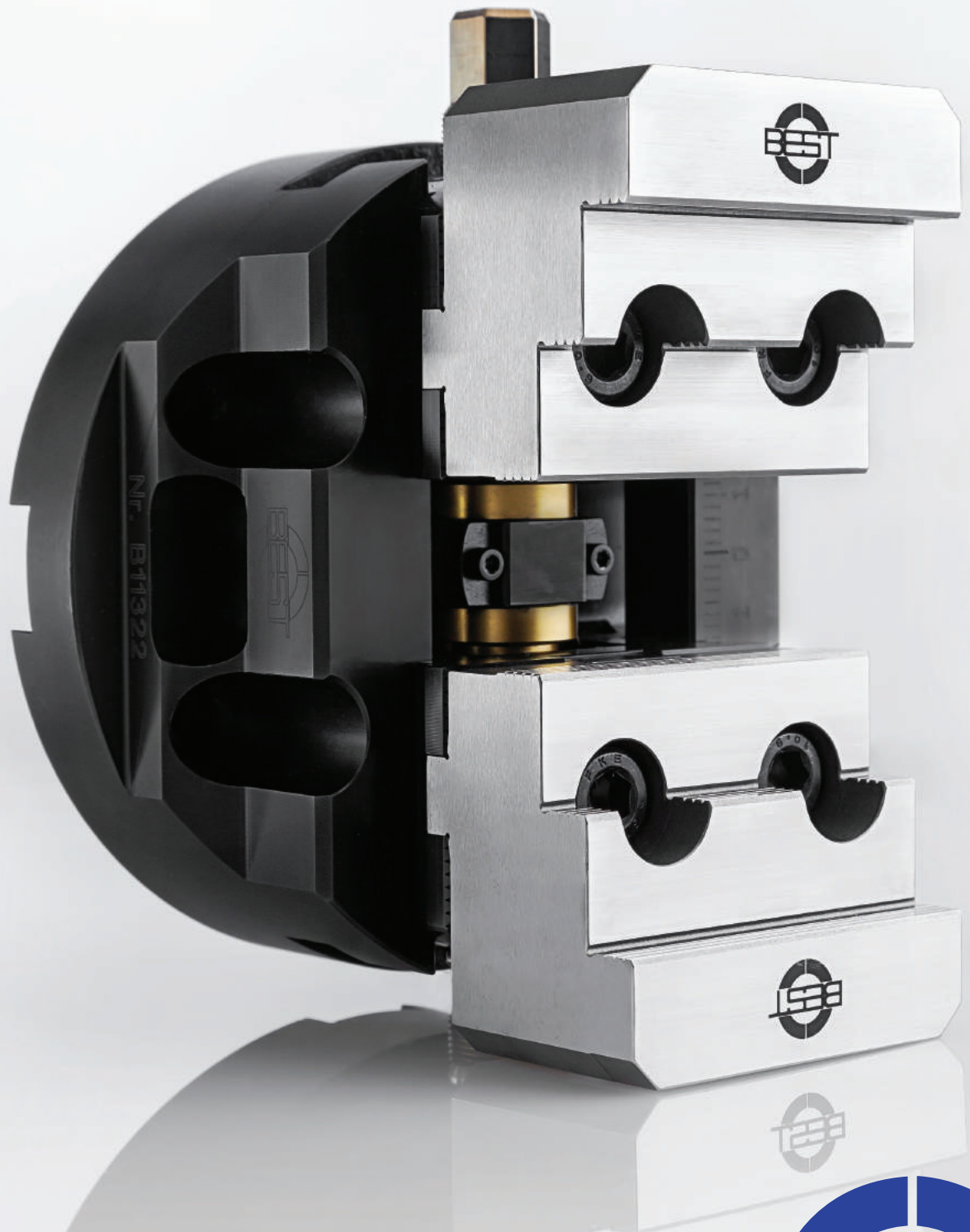

valid from September 2016

The Company

The BEST company is a family-owned company with headquarters in Filderstadt-Bonlanden near the Stuttgart Airport.

BEST is a company that specialises in axial clamping technology and is a high-quality supplier in the area of clamping technology.



BEST GmbH is managed under one roof with Hugo Reckerth GmbH. Reckerth develops and manufactures highly precise spindles for milling, drilling, turning, and grinding machines utilized in wood, plastic, and metal-processing commercial applications (additional information can be found on page 81 or at www.reckerth.de).



Quality, reliability and punctuality are the top priorities of BEST and Reckerth. The achievement of these objectives is supported by our quality management system, which is certified to DIN EN ISO 9001: 2015. These are applied in all areas of our business operations, from development, design, and production right through to sales. These are implemented and put into practice by our team of highly qualified employees.



We are proud to present to you our new catalogue, which will give you a comprehensive overview of our product variety.

Our range of products includes mechanical, pneumatic and hydraulic centric vices together with a comprehensive jaw range and a mechanical zero point system.

Maximum customer benefit is our number one priority. The midsize operation enables us to rapidly respond to your individual requests. In addition, to our standard products, we can develop workpiece-specific special solutions for you, even for a comparably small number of items. Simply send us the workpiece to be clamped, ideally in Step format. Our design engineers also take the type of processing, the desired clamping method, and similar details into account when designing your individual clamping solution.

Based on your specifications, we will develop the fitting solution.

Adaptations to your existing machines, tombstones or a zero point system are also possible.



If you are interested in finding out more about the services of the BEST GmbH, if you have questions, would like an offer or need a consultation appointment, please don't hesitate to contact us. We at BEST will gladly help you with all matters related to clamping technology and can provide you with competent help. You can reach us by telephone, fax or email. We will respond to you immediately and discuss everything with you in a personal consultation.

BEST GmbH
Modular clamping technology and automation
Raiffeisenstrasse 15
D – 70794 Filderstadt-Bonlanden
Tel. +49 (0)711 / 722579-70
Fax +49 (0)711 / 722579-99
info@best-spanntechnik.de
www.best-spanntechnik.de

Table of contents

1.	Mechanical centric vices	Page 6
1.1	BSM line	Page 6
1.1.1	BSM-115-SWBA	Page 7
1.1.2	BSM-115-KV	Page 8
1.1.3	BSM-140	Page 9
1.1.4	BSM-180	Page 10
1.1.5	BSM-250	Page 11
1.1.6	BSM-500	Page 12
1.1.7	Special size BSM-400	Page 13
1.2	BSMG line	Page 14
1.2.1	BSMG-140	Page 15
1.2.2	BSMG-180	Page 16
1.2.3	BSMG-250	Page 17
1.2.4	BSMG-500	Page 18
1.2.5	Special size BSMG-400	Page 19
1.3	Miniature vices	Page 20
1.3.1	BSM-040 with blank jaws	Page 20
1.3.2	BSM-040 with grip jaws	Page 21
1.3.3	5-axis clamping jaw for miniature vices	Page 22
1.4	Special solutions	Page 23
1.5	Sample applications	Page 24-29
2.	Jaw range	Page 30
2.1	Quick-change jaws	Page 30
2.1.1	Jaw blanks	Page 30
2.1.2	Stepped jaws	Page 31
2.1.3	Grip jaws	Page 31
2.1.4	Pendulum grip jaws	Page 32
2.1.5	Prism jaws	Page 32
2.2	Tongue and groove jaws	Page 33
2.2.1	Jaw blanks	Page 33
2.2.2	Stepped jaws	Page 34
2.2.3	Grip jaws	Pages 34-35
2.2.4	5-axis jaws	Page 35
2.2.5	Prism jaws	Page 36
2.2.6	Vario jaws	Page 37
2.3	Spare parts and accessories	Page 38-39
3.	Zero-point vices	Page 40
3.1	Realpoint zero-point clamping system	Page 40
3.1.1	RPC/RPCG centric vices	Page 41
3.1.2	Baseplates	Page 42
3.1.3	Pallets	Page 42
3.1.4	Epoxy mineral tombstones	Page 43
3.1.5	5-axis riser	Page 44
3.1.6	5-axis pyramids	Page 45
3.1.7	5-axis pyramid tombstone	Page 46
3.1.8	Accessories	Pages 47-48

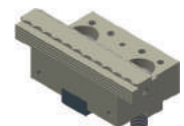
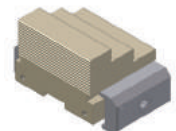
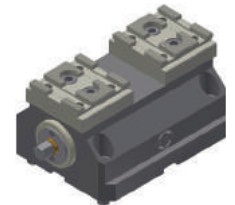
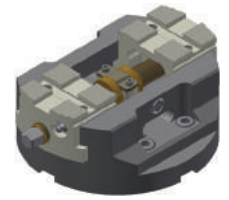
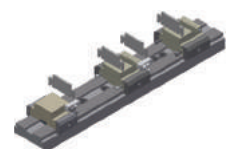
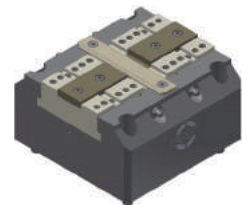
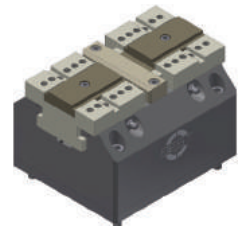

Table of contents

3.2	Adaptation to zero-point systems of other manufacturers	Pages 49-50
4.	Adaptation to rotary tables	Page 51
5.	Vices for automation solutions	Page 52
5.1	Pneumatic vice models	Page 52
5.1.1	Pneumatic centric vices	Page 52
5.1.1.1	BSP-64	Page 53
5.1.1.2	BSP-100	Page 54
5.1.1.3	BSP-160	Page 55
5.1.1.4	BSPD-170-SWBA	Page 56
5.1.1.5	BSPD-170-KV	Page 57
5.1.1.6	BSPD-250-SWBA	Page 58
5.1.1.7	BSPD-250-KV	Page 59
5.1.1.8	Special size BSPD-64-KV	Page 60
5.1.1.9	Special size BSPD-420-KV	Page 61
5.1.1.10	Special size with maintenance of pressure	Page 62
5.1.2	Sample applications	Page 63
5.1.3	Pneumatic vice BSP-125-FB	Pages 64-65
5.2	Hydraulic vice models	Page 66
5.2.1	Hydraulic centric vices	Page 66
5.2.1.1	BSH-64	Page 67
5.2.1.2	BSH-100	Page 68
5.2.1.3	BSH-160	Page 69
5.2.1.4	BSH-250	Page 70
5.2.1.5	BSH-500	Page 71
5.2.1.6	Special size BSH-116	Page 72
5.2.1.7	Special size BSH-290	Page 73
5.2.2	Hydraulic compensation vice BSHAN-155	Page 74-75
5.2.3	Sample applications	Page 76
5.3	Optional additional functions for automated centric vices	Pages 77-78
6.	Multi-point clamping strips	Page 79
7.	Customer-specific solutions	Page 80
8.	Hugo Reckerth GmbH – Spindelbau	Page 81
	Terms and conditions	Page 82



Definitions of technical specifications in this catalogue:

- Clamping range:

The clamping range is dependent on the top jaw. The clamping range specified with each vice model is the respective, theoretically possible clamping range.

- Clamping force:

The clamping force is the sum of the individual forces occurring at the clamping jaws.

1. Mechanical centric vices

1.1 BSM line

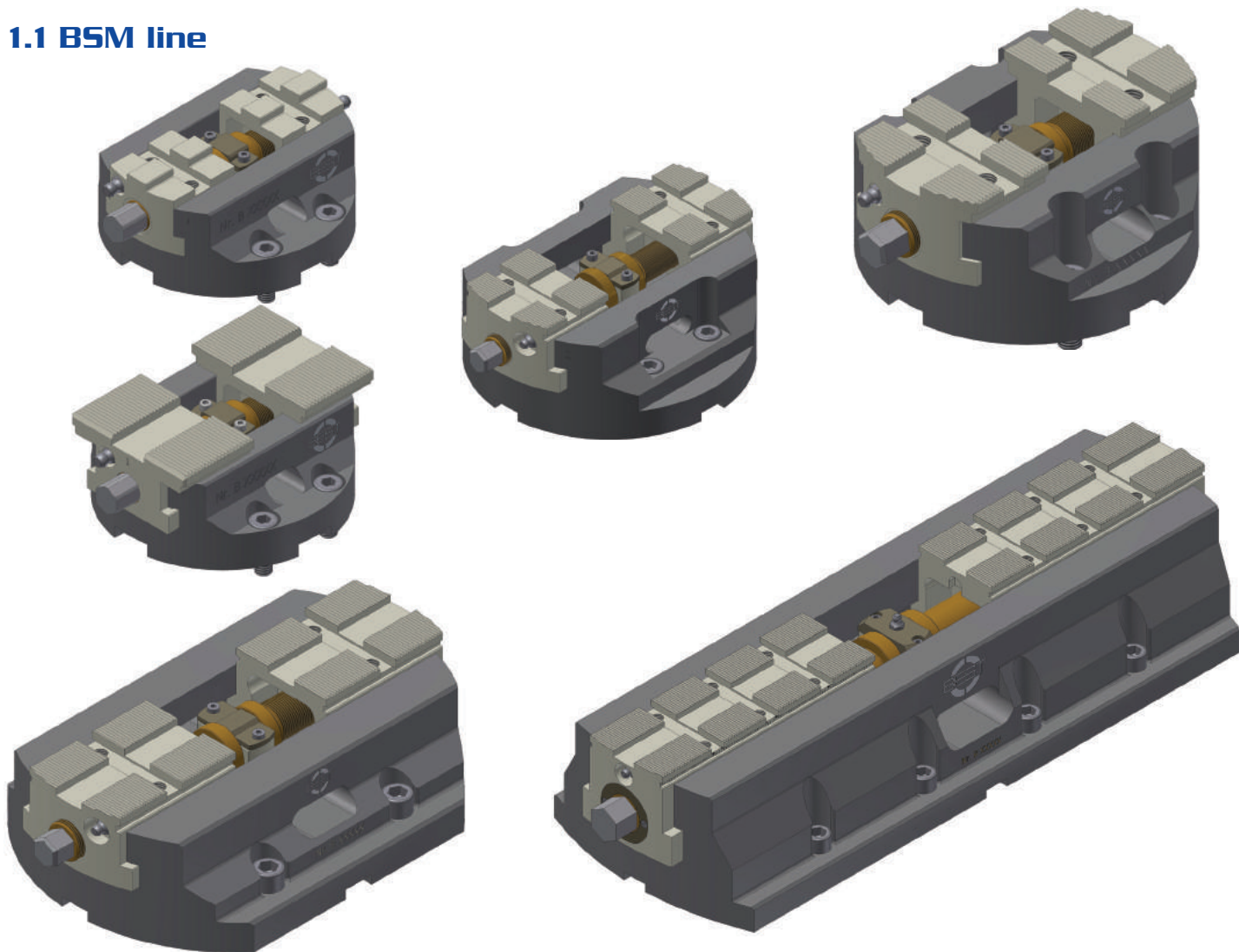

Advantages of BSM centric vices:

- Low-obstruction contours and extremely flat design for optimum flexibility and multi-axis machining centres
- Extremely high clamping forces (up to 100 kN)
- Up to 50 mm stroke / jaw
- Housing sizes from 115 mm to 500 mm
- Repetition accuracy of 0.005 mm (with ground-in jaws)
- Centring accuracy of +/- 0.01 mm (with ground in jaws)
- Jaw widths of up to 500 mm
- Combined quick-change jaw connection and tongue and groove from model size BSM140 onward
- Ground-in threaded spindle
- Low wear due to nitrogen-hardened surfaces
- Depending on requirements, the BSM centric vice can be screwed conventionally to the machining table or used as a RPC zero-point centric vice on the BEST Realpoint system
- The BSM centric vice can be adapted for use with zero-point systems of other manufacturers

1.1.1 Mechanical centric vice BSM-115-SWBA

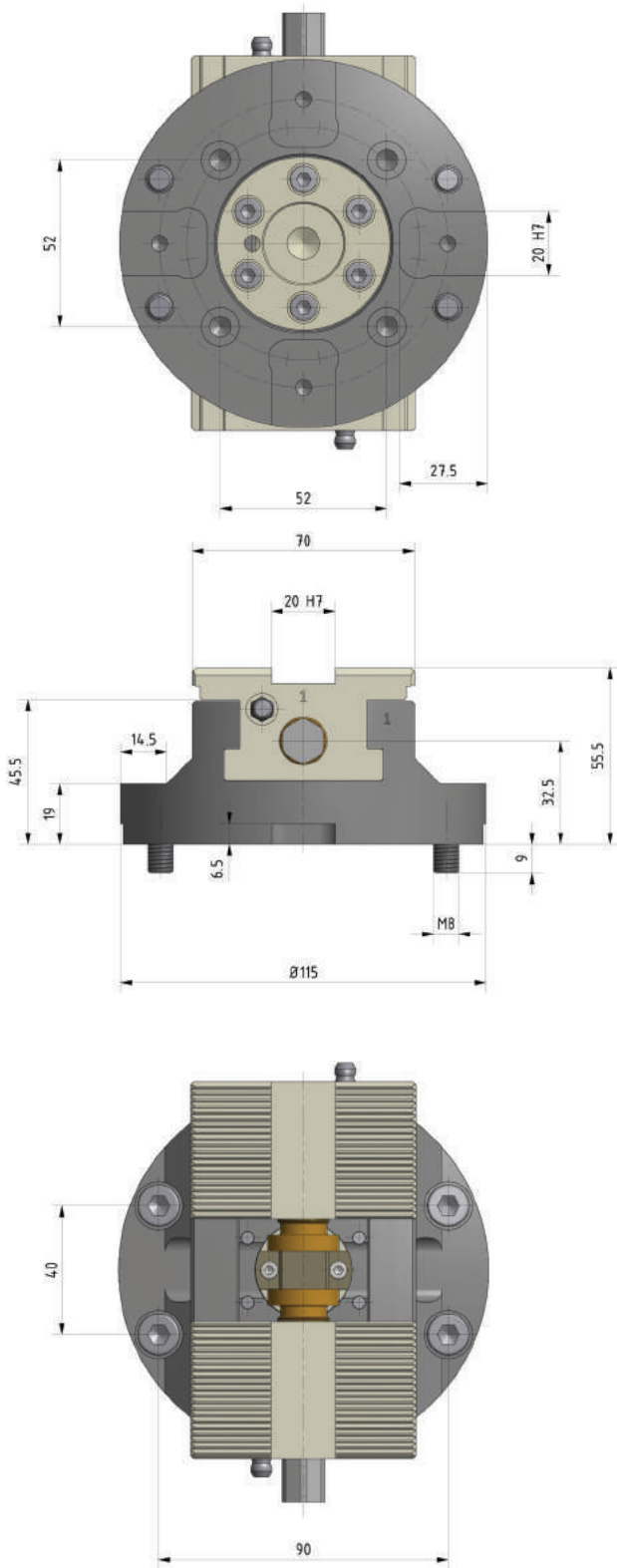

Technical data:

Order number:	200-0115-012
Designation:	BSM-115-SWBA
Installation length:	Ø 115 mm
Installation height:	55.5 mm
Weight:	2.96 kg
Clamping range:	0 – 100 mm
Stroke per jaw:	15 mm
Max. torque:	120 Nm
Max. clamping force:	48 kN
Jaw connection:	Quick-change

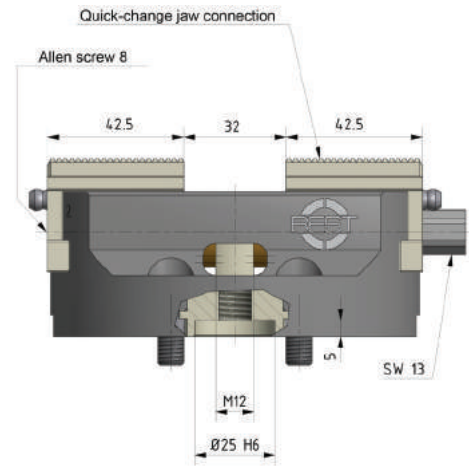

Clamping force – torque BSM-115

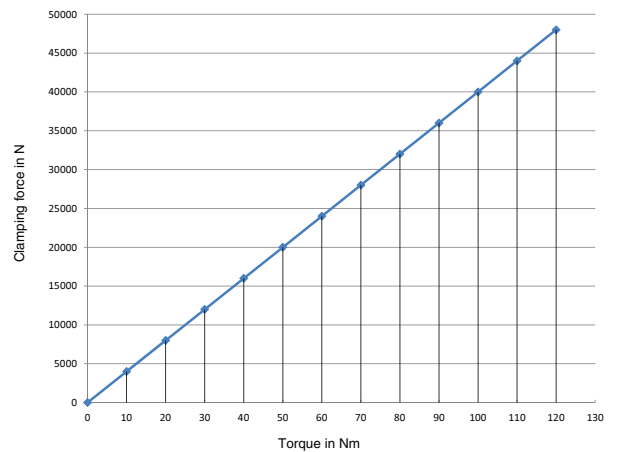

Installation options for the BSM-115-SWBA:

- The centric vice BSM-115-SWBA can be attached to the machining table from the top using screws or steel ties or on a pallet using screws or clamps.
- The BSM-115-SWBA can be quickly upgraded to an RPC-115-SWBA zero-point centric vice (see page 41) simply by fitting a tightening bolt and two alignment bolts (see page 47).

You can find the corresponding jaws for the centric vice on pages 30 to 32.

1.1.2 Mechanical centric vice BSM-115-KV

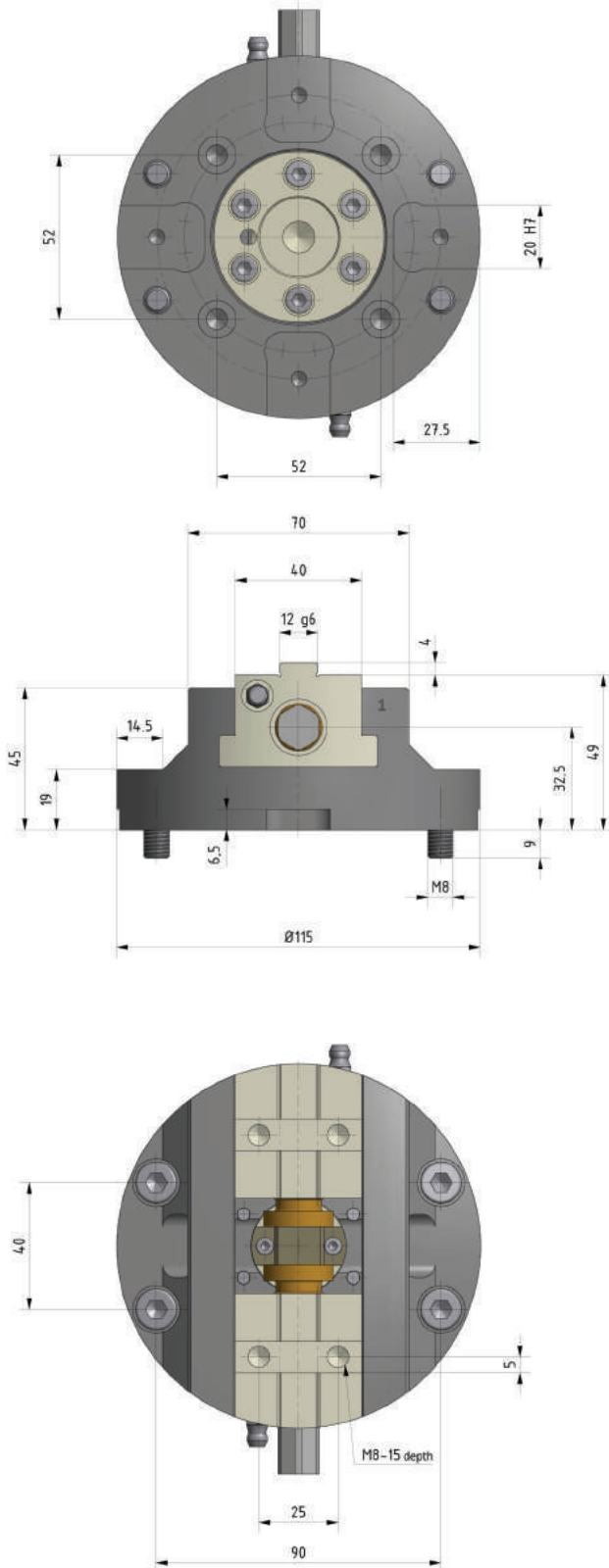

Technical data:

Order number:	200-0115-014
Designation:	BSM-115-KV
Installation length:	Ø 115 mm
Installation height:	49 mm
Weight:	2.96 kg
Clamping range:	0 – 100 mm
Stroke per jaw:	15 mm
Max. torque:	120 Nm
Max. clamping force:	48 kN
Jaw connection:	Tongue and groove

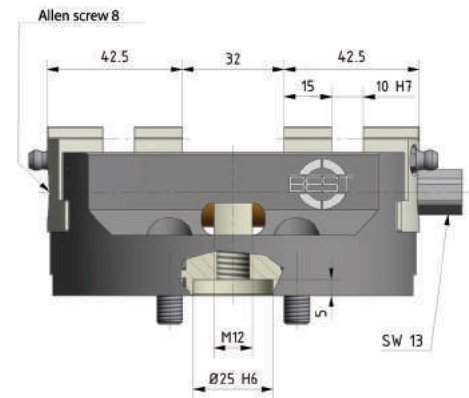

Clamping force – torque BSM-115

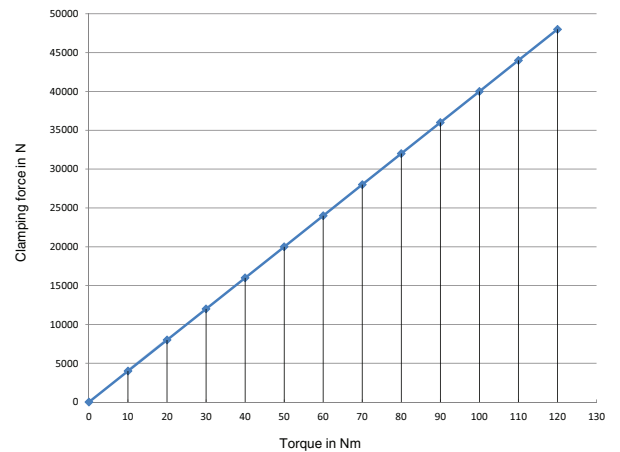

Installation options for the BSM-115-KV:

- The centric vice BSM-115-KV can be attached to the machining table from the top using screws or steel ties or on a pallet using screws or clamps.
- The BSM-115-KV can be quickly upgraded to an RPC-115-KV zero-point centric vice (see page 41) simply by fitting a tightening bolt and two alignment bolts (see page 47).

You can find the corresponding jaws for the centric vice on pages 33 to 37.

1.1.3 Mechanical centric vice BSM-140

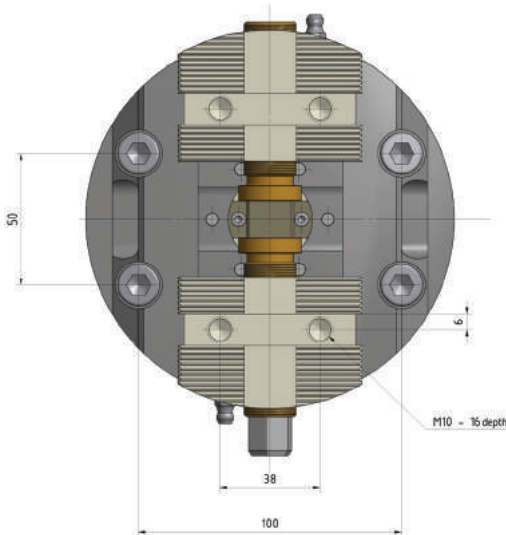
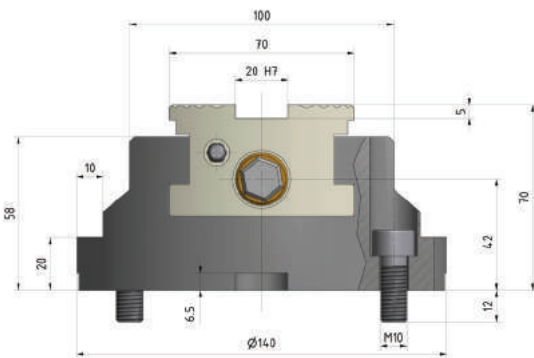
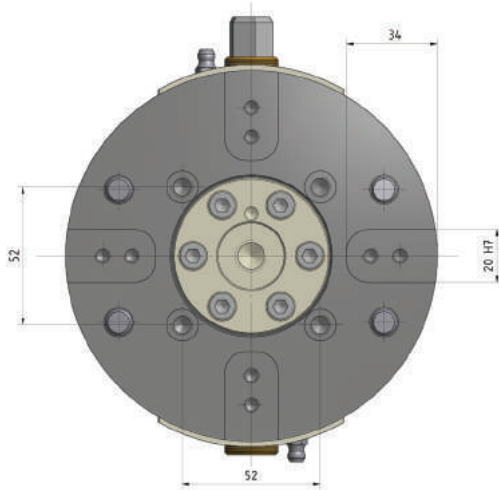

Technical data:

Order number:	200-0140-010
Designation:	BSM-140
Installation length:	Ø 140 mm
Installation height:	70 mm
Weight:	5.6 kg
Clamping range:	0 – 120 mm
Stroke per jaw:	25 mm
Max. torque:	120 Nm
Max. clamping force:	52 kN
Jaw connection:	Quick-change and tongue and groove

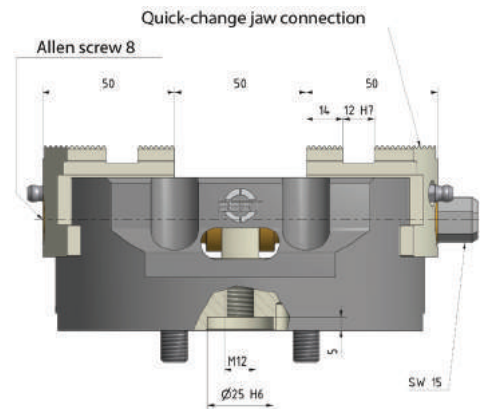

Clamping force – torque BSM-140

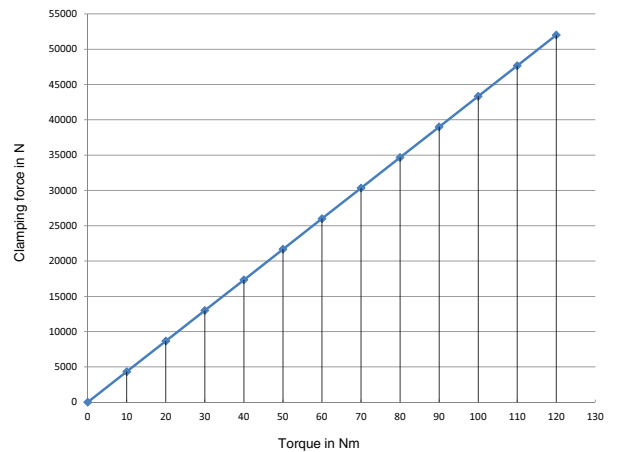

Installation options for the BSM-140:

- The centric vice BSM-140 can be attached from the top to the machining table using screws or steel ties or on a pallet using screws or clamps.
- The BSM-140 can be quickly upgraded to an RPC-140 zero-point centric vice (see page 41) simply by fitting a tightening bolt and two alignment bolts (see page 47).

You can find the corresponding jaws for the centric vice on pages 30 to 37.

1.1.4 Mechanical centric vice BSM-180

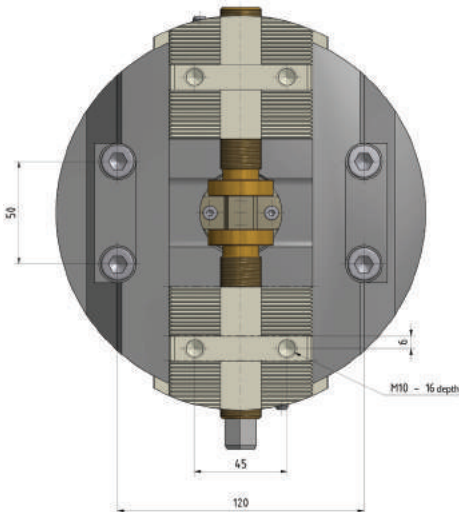
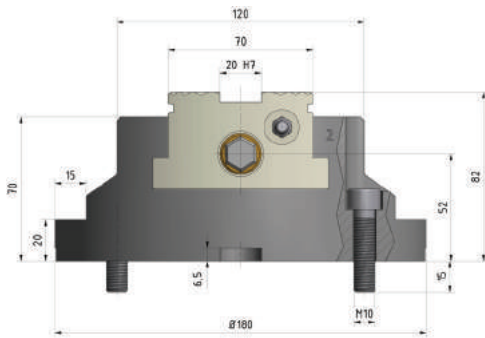
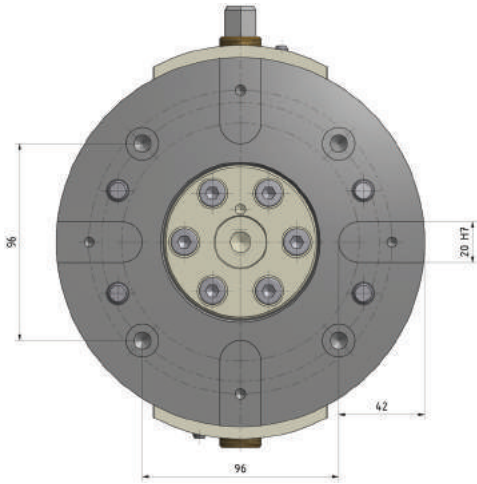

Technical data:

Order number:	200-0180-010
Designation:	BSM-180
Installation length:	Ø 180 mm
Installation height:	82 mm
Weight:	10.9 kg
Clamping range:	0 – 160 mm
Stroke per jaw:	35 mm
Max. torque:	120 Nm
Max. clamping force:	60 kN
Jaw connection:	Quick-change and tongue and groove

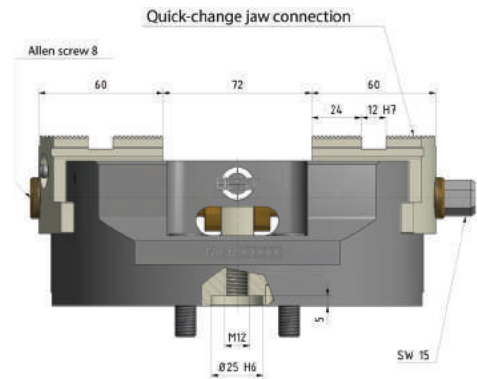

Clamping force – torque BSM-180

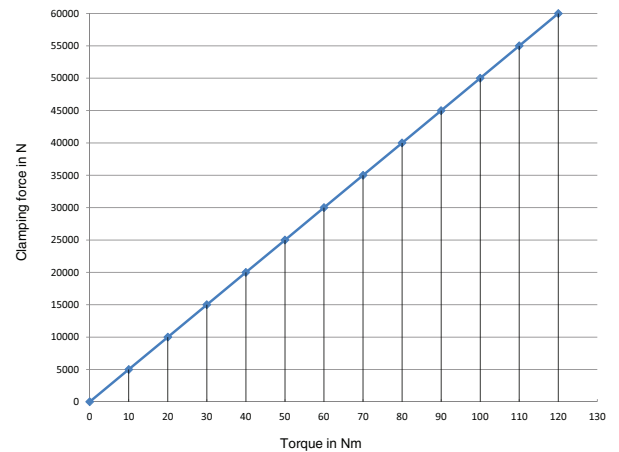

Installation options for the BSM-180:

- The centric vice BSM-180 can be attached from the top to the machining table using screws or steel ties or on a pallet using screws or clamps.
- The BSM-180 can be quickly upgraded to an RPC-180 zero-point centric vice (see page 41) simply by fitting a tightening bolt and two alignment bolts (see page 47).

You can find the corresponding jaws for the centric vice on pages 30 to 37.

1.1.5 Mechanical centric vice BSM-250

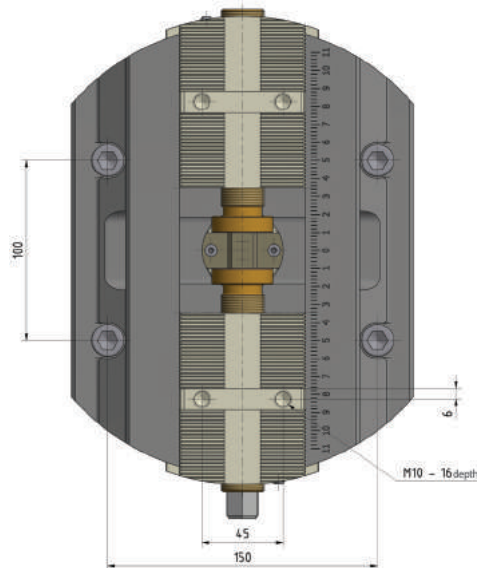
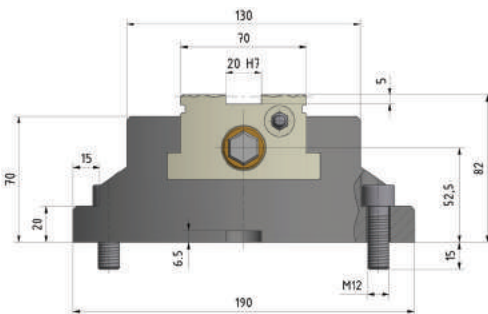
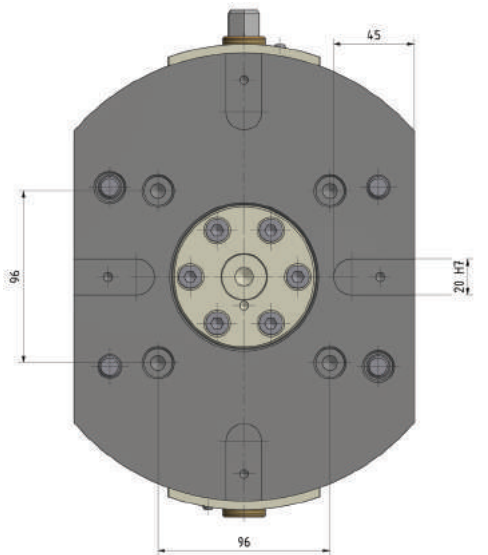

Technical data:

Order number:	200-0250-010
Designation:	BSM-250
Installation length:	Ø 250 mm
Installation height:	82 mm
Weight:	19 kg
Clamping range:	0–250 mm
Stroke per jaw:	35 mm
Max. torque:	250 Nm
Max. clamping force:	100 kN
Jaw connection:	Quick-change and tongue and groove

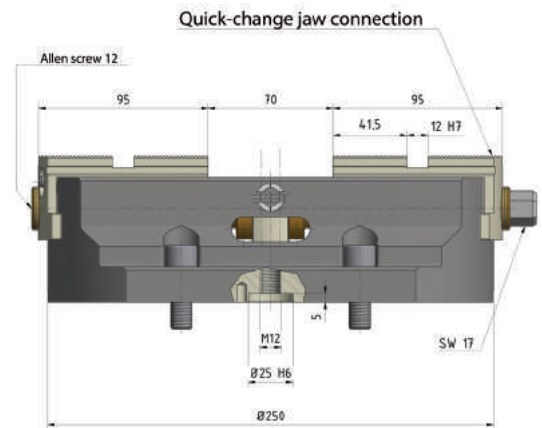

Clamping force – torque BSM-250

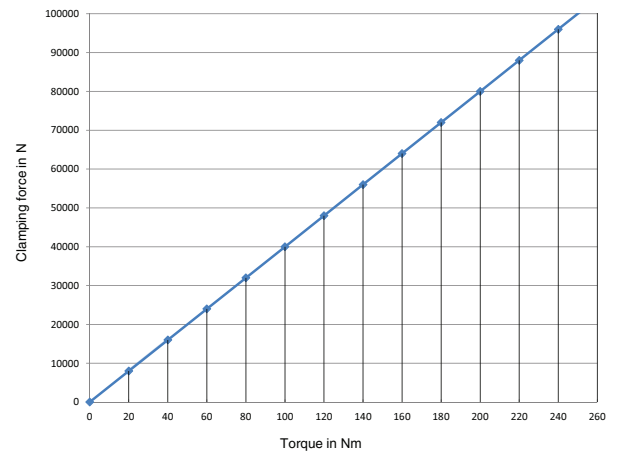

Installation options for the BSM-250:

- The centric vice BSM-250 can be attached from the top to the machining table using screws or steel ties or on a pallet using screws or clamps.
- The BSM-250 can be quickly upgraded to an RPC-250 zero-point centric vice (see page 41) simply by fitting a tightening bolt and two alignment bolts (see page 47).

You can find the corresponding jaws for the centric vice on pages 30 to 37.

1.1.6 Mechanical centric vice BSM-500

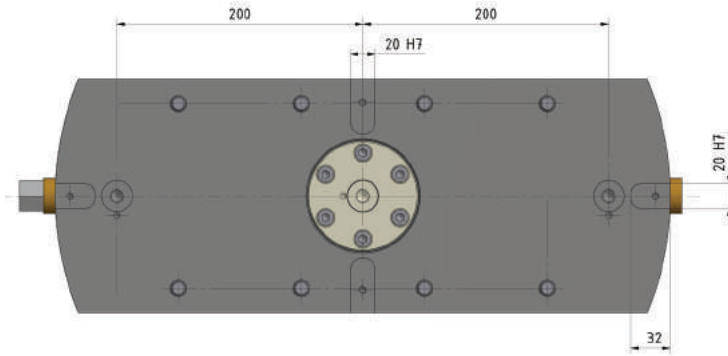

Technical data:

Order number:	200-0500-010
Designation:	BSM-500
Installation length:	500 mm
Installation height:	112 mm
Weight:	59 kg
Clamping range:	0–500 mm
Stroke per jaw:	55 mm
Max. torque:	250 Nm
Max. clamping force:	80 kN
Jaw connection:	Quick-change and tongue and groove

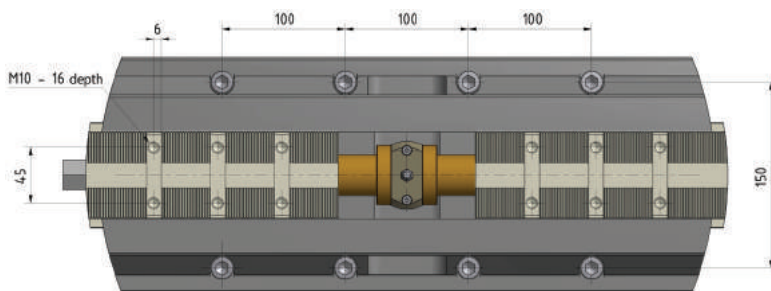
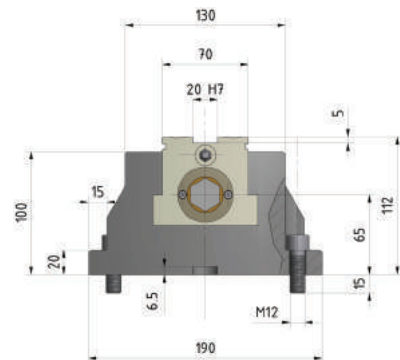
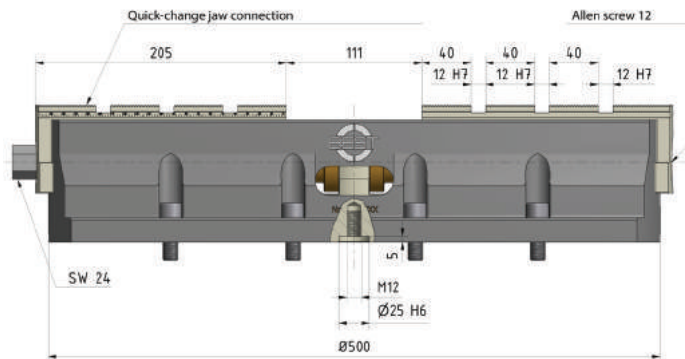

Clamping force – torque BSM-500

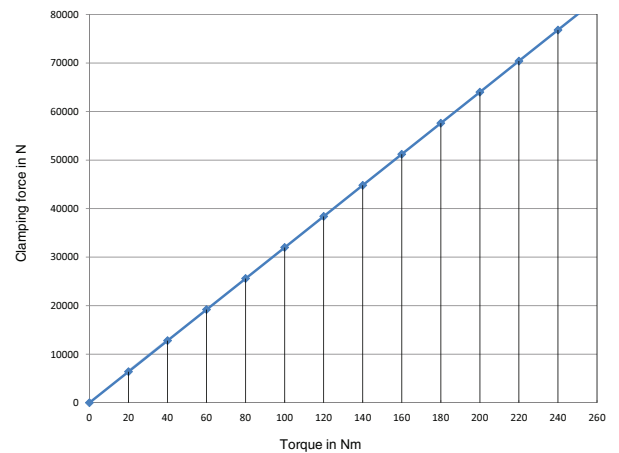

Installation options for the BSM-500:

- The centric vice BSM-500 can be attached from the top to the machining table using screws or steel ties or on a pallet using screws or clamps.
- The BSM-500 can be quickly upgraded to an RPC-500 zero-point centric vice (see page 41) simply by fitting a tightening bolt and a sword-shaped tightening bolt (see page 47).

You can find the corresponding jaws for the centric vice on pages 30 to 37.

1.1.7 Mechanical centric vice special size BSM-400

Technical data:

Order number:	200-0400-001
Designation:	BSM-400
Installation length:	400 mm
Installation height:	112 mm
Weight:	45 kg
Clamping range:	0–400 mm
Stroke per jaw:	45 mm
Max. torque:	250 Nm
Max. clamping force:	80 kN
Jaw connection:	Quick-change and tongue and groove

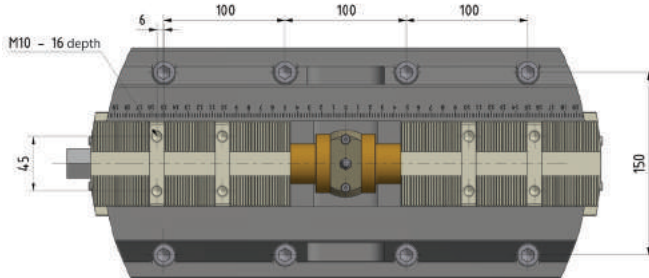
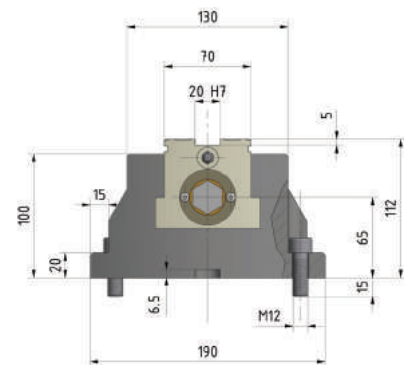
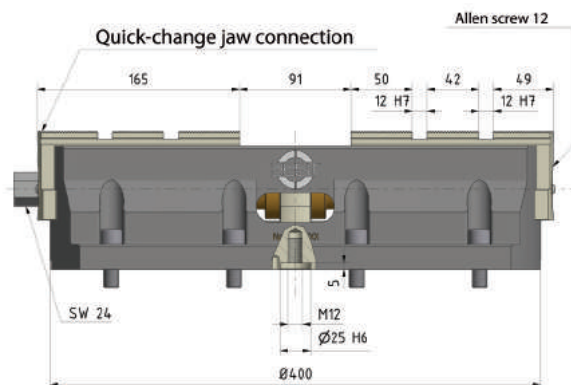
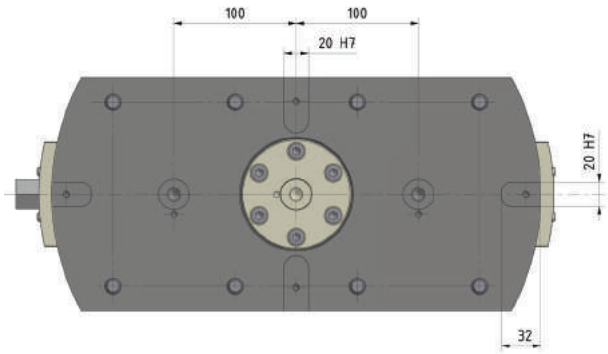

Clamping force – torque BSM-400

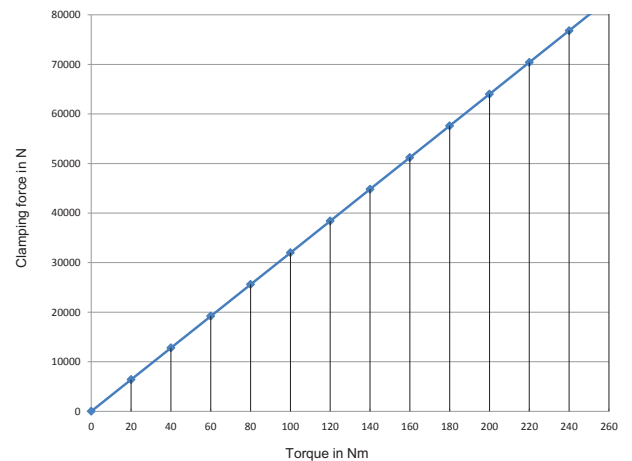

Installation options for the BSM-400:

- The centric vice BSM-400 can be attached from the top to the machining table using screws or steel ties or on a pallet using screws or clamps.
- The BSM-400 can be quickly upgraded to an RPC-400 zero-point centric vice simply by fitting a tightening bolt and a sword-shaped tightening bolt (see page 47).

You can find the corresponding jaws for the centric vice on pages 30 to 37.

1.2 BSMG line

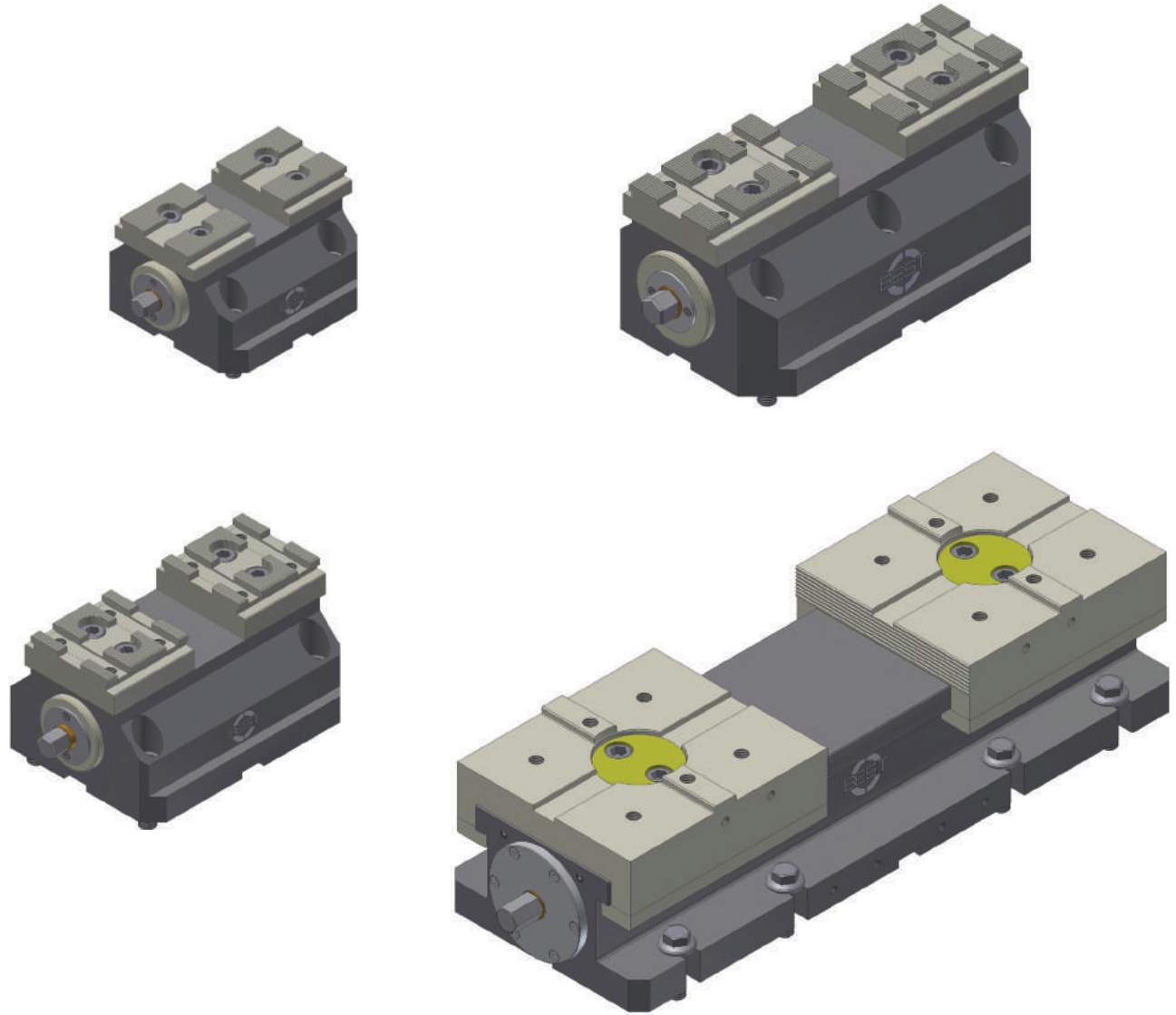

Advantages of BSMG centric vices:

- Highest-possible degree of process reliability in unmanned production operations as a result of the encapsulated design, which prevents soiling on the inside of the centric vice (with use of purge air)
- Extremely high rigidity as a result of solid design
- Extremely high clamping forces (up to 100 kN)
- Housing sizes from 140 mm to 500 mm
- Repetition accuracy of 0.005 mm (with ground-in jaws)
- Centring accuracy of +/- 0.01 mm (with ground in jaws)
- Jaw widths of up to 500 mm
- Low wear due to nitrogen-hardened surfaces
- Depending on requirements, the BSMG centric vice can be screwed conventionally to the machining table or used as a RPCG zero-point centric vice on the BEST Realpoint system

1.2.1 Encapsulated centric vice BSMG-140

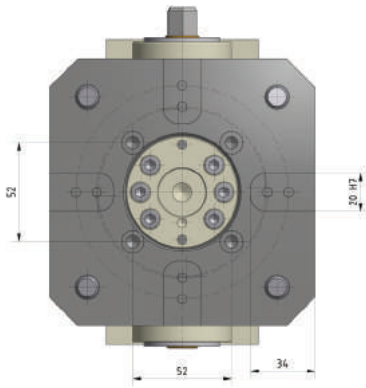

Technical data:

Order number:	220-0140-004
Designation:	BSMG-140
Installation length:	140 mm
Installation height:	97 mm
Weight:	10 kg
Clamping range:	0 – 130 mm
Stroke per jaw:	18 mm
Max. torque:	120 Nm
Max. clamping force:	40 kN
Jaw connection:	Quick-change

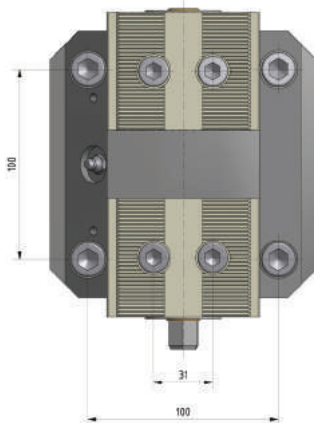
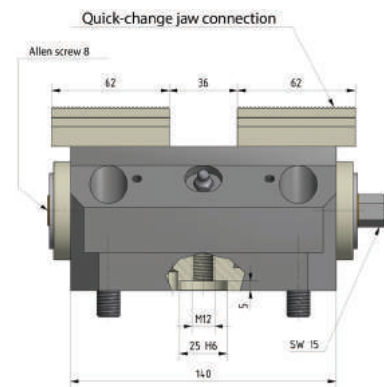
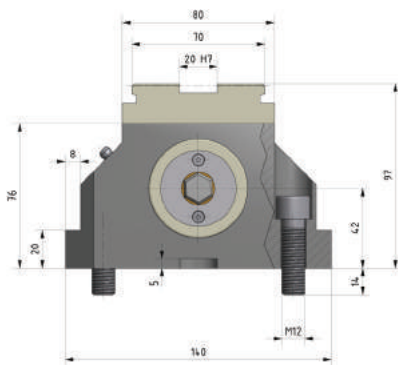

Clamping force – torque BSMG-140

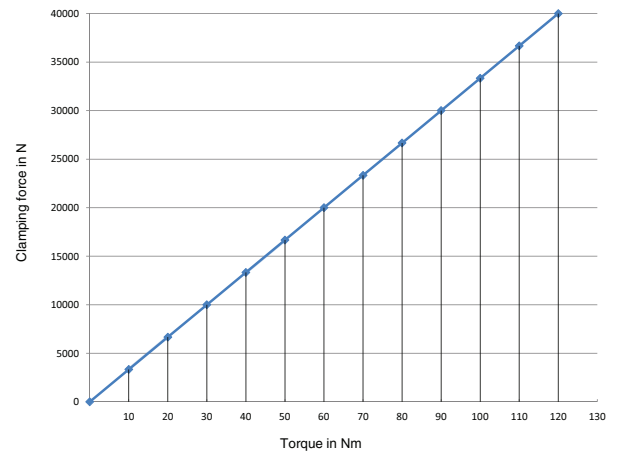

Installation options for the BSMG-140:

- The BSMG-140 centric vice can be attached to the machining table from above using screws or steel ties.
- The BSMG-140 can be quickly upgraded to an RPCG-140 zero-point centric vice (see page 41) simply by fitting a tightening bolt and two alignment bolts (see page 47).

You can find the corresponding jaws for the centric vice on pages 30 to 32.

1.2.2 Encapsulated centric vice BSMG-180

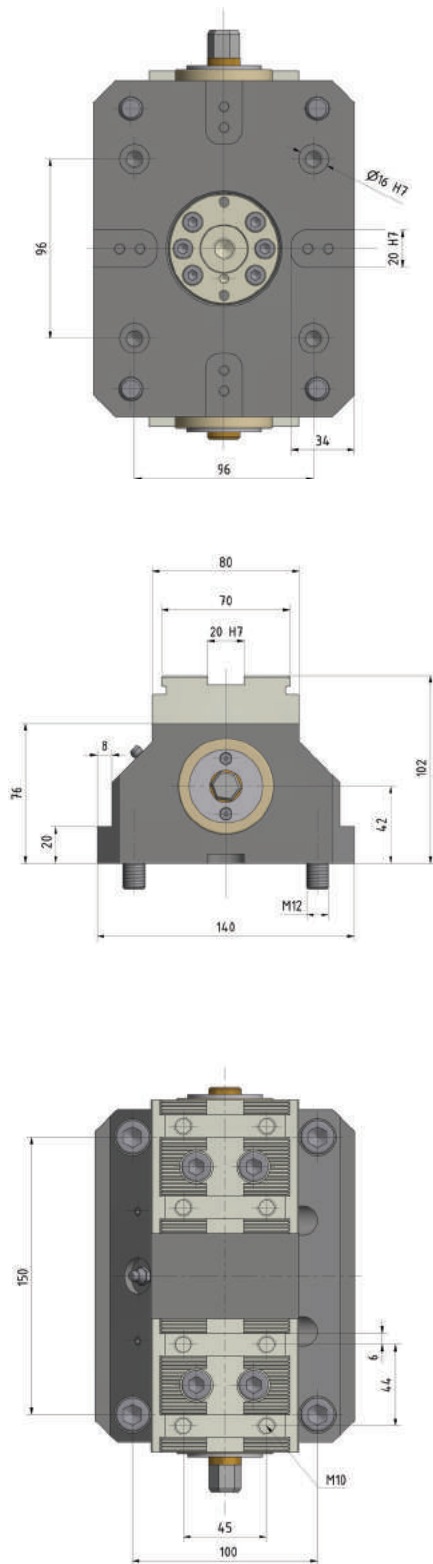

Technical data:

Order number:	220-0180-004
Designation:	BSMG-180
Installation length:	180 mm
Installation height:	102 mm
Weight:	13 kg
Clamping range:	0 – 170 mm
Stroke per jaw:	23 mm
Max. torque:	120 Nm
Max. clamping force:	40 kN
Jaw connection:	Quick-change and tongue and groove

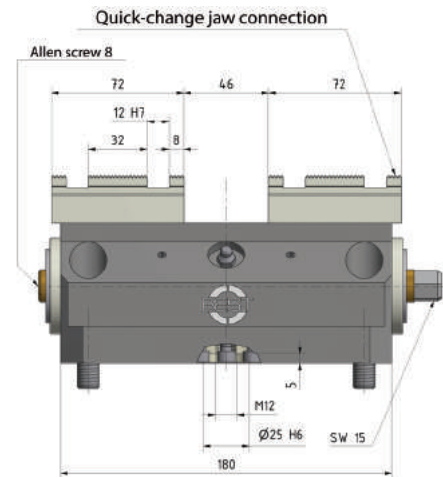

Clamping force – torque BSMG-180

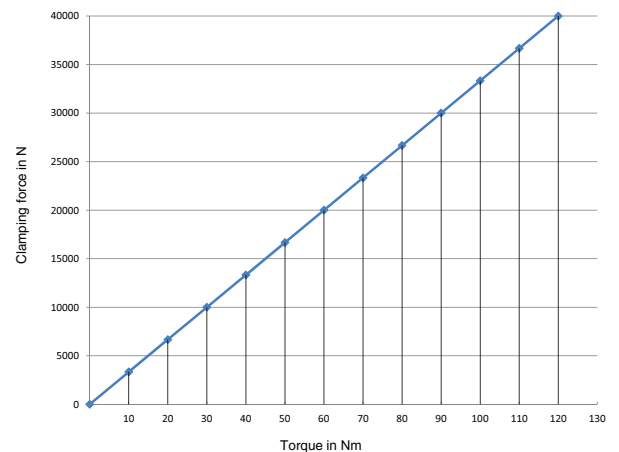

Installation options for the BSMG-180:

- The BSMG-180 centric vice can be attached to the machining table from above using screws or steel ties.
- The BSMG-180 can be quickly upgraded to an RPCG-180 zero-point centric vice (see page 41) simply by fitting a tightening bolt and two alignment bolts (see page 47).

You can find the corresponding jaws for the centric vice on pages 30 to 37.

1.2.3 Encapsulated centric vice BSMG-250

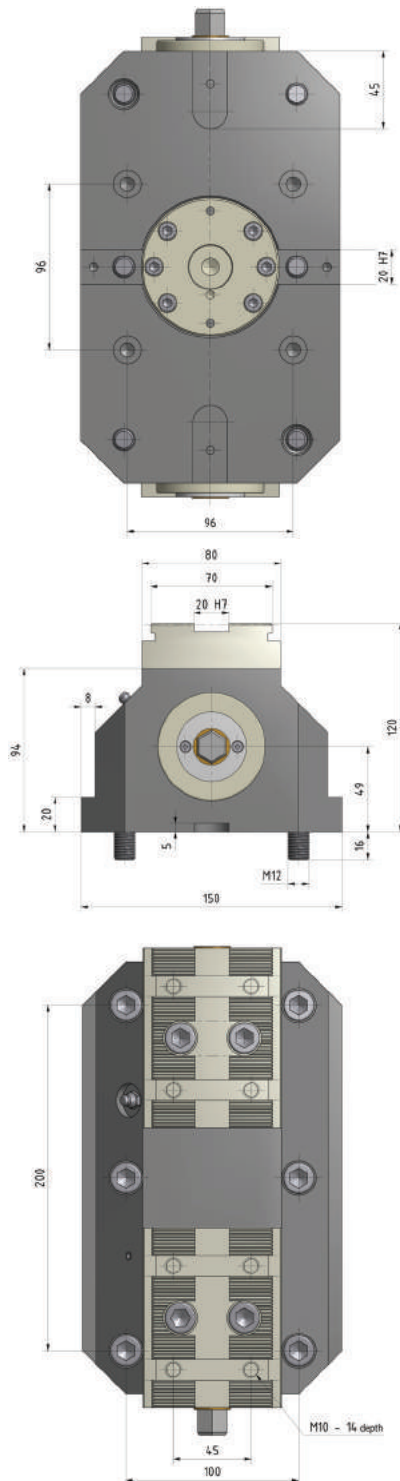

Technical data:

Order number:	220-0250-004
Designation:	BSMG-250
Installation length:	250 mm
Installation height:	120 mm
Weight:	23 kg
Clamping range:	0–240 mm
Stroke per jaw:	29 mm
Max. torque:	250 Nm
Max. clamping force:	90 kN
Jaw connection:	Quick-change and tongue and groove

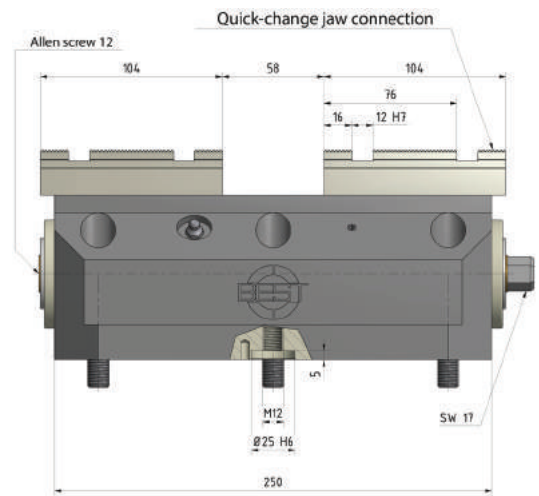

Clamping force – torque BSMG-250

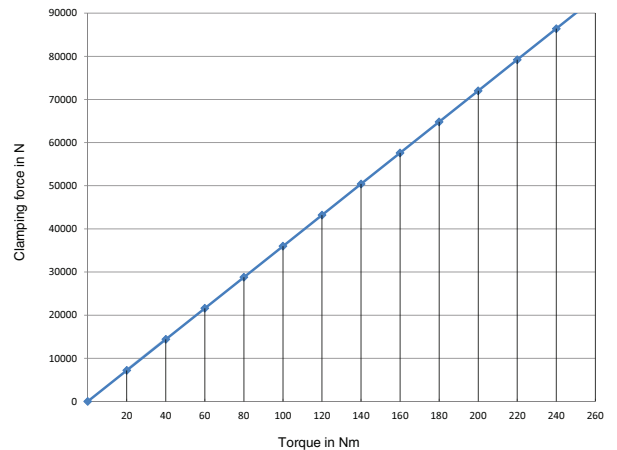

Installation options for the BSMG-250:

- The BSMG-250 centric vice can be attached to the machining table from above using screws or steel ties.
- The BSMG-250 can be quickly upgraded to an RPCG-250 zero-point centric vice (see page 41) simply by fitting a tightening bolt and two alignment bolts (see page 47).

You can find the corresponding jaws for the centric vice on pages 30 to 37.

1.2.4 Encapsulated centric vice BSMG-500

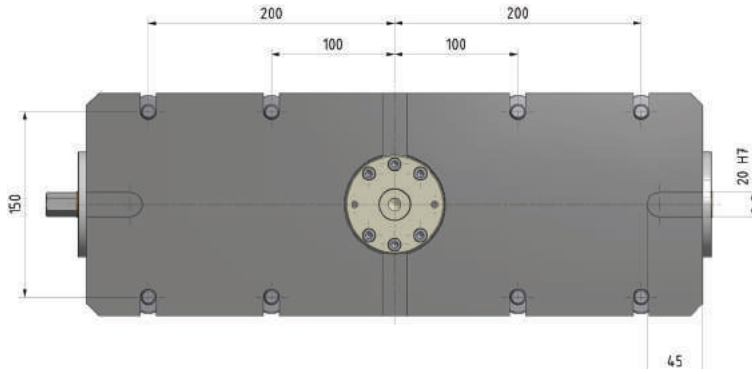

Technical data:

Order number:	220-0500-200
Designation:	BSMG-500
Installation length:	500 mm
Installation height:	119 mm
Weight:	70 kg
Clamping range:	0–500 mm
Stroke per jaw:	65 mm
Max. torque:	250 Nm
Max. clamping force:	93 kN
Jaw connection:	Tongue and groove

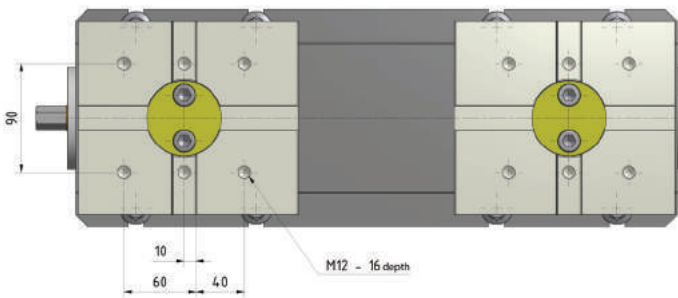
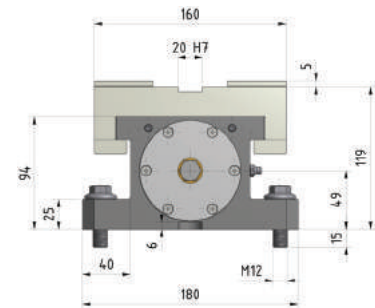
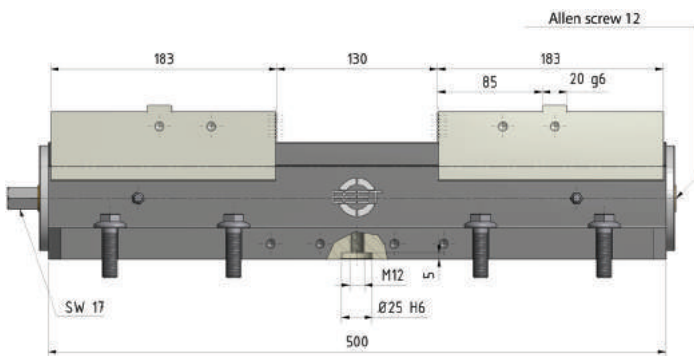

Clamping force – torque BSMG-500

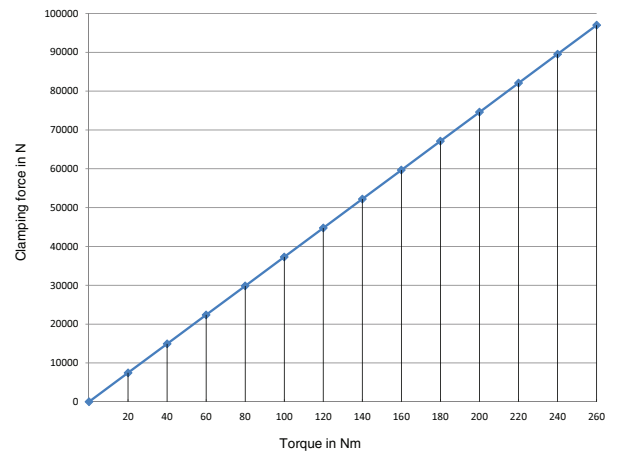

Installation options for the BSMG-500:

- The BSMG-500 centric vice can be attached to the machining table from above using screws or steel ties. You can find the corresponding jaws for the centric vice on pages 33 to 37.

1.2.5 Encapsulated centric vice special size BSMG-400

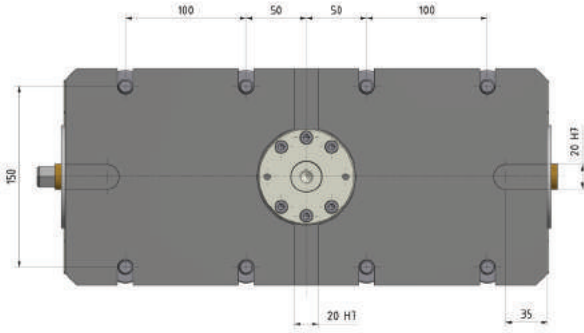

Technical data:

Order number:	220-0400-001
Designation:	BSMG-400
Installation length:	400 mm
Installation height:	119 mm
Weight:	48 kg
Clamping range:	0–400 mm
Stroke per jaw:	50 mm
Max. torque:	250 Nm
Max. clamping force:	93 kN
Jaw connection:	Tongue and groove

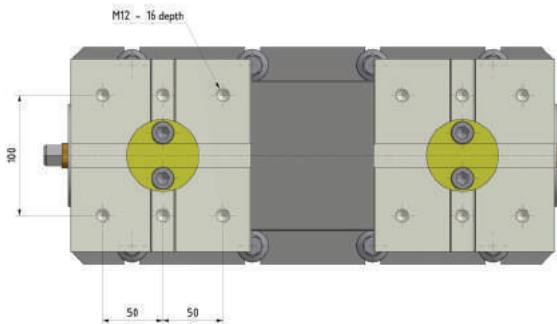
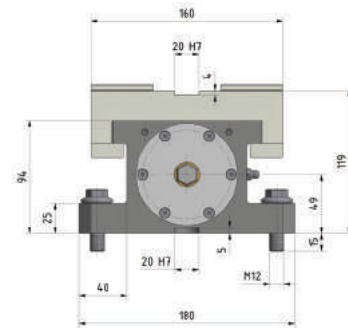
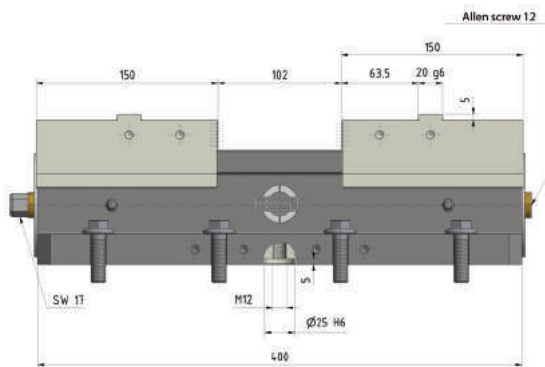

Clamping force – torque BSMG-400

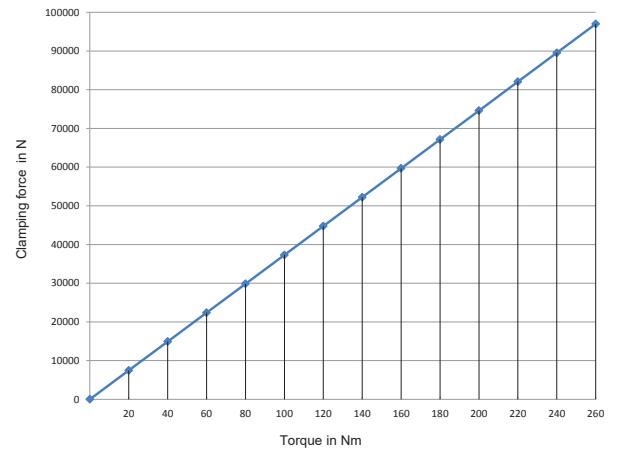

Installation options for the BSMG-400:

- The BSMG-400 centric vice can be attached to the machining table from above using screws or steel ties.

1.3 Miniature vices

1.3.1 BSM-040 with blank jaws

Technical data:

Order number:	200-0040-001	200-0040-002	200-0040-003
Designation:	BSM-040	BSM-040	BSM-040
Dimensions (LxWxH):	40 x 40 x 30 mm	40 x 40 x 34 mm	40 x 40 x 44 mm
Weight:	about 500 g	about 500 g	about 500 g
Clamping range:	0–34 mm	0–34 mm	0–34 mm
Stroke per jaw:	5 mm	5 mm	5 mm
Max. torque:	7 Nm	7 Nm	7 Nm
Max. clamping force:	16 kN	16 kN	16 kN
Repeat accuracy:	+/- 0.02 mm		
Jaw connection:	Clamping jaws screwed onto spindle		

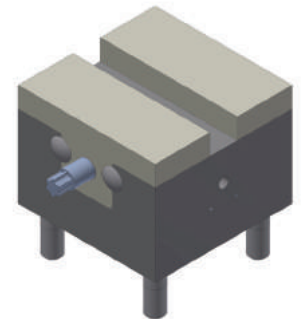
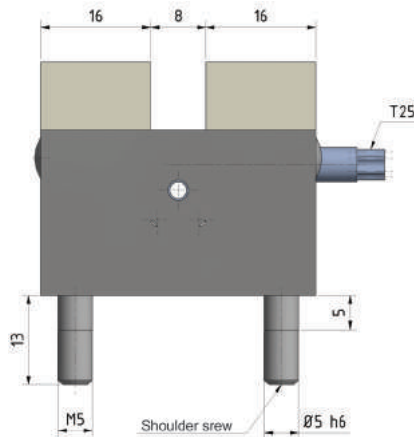
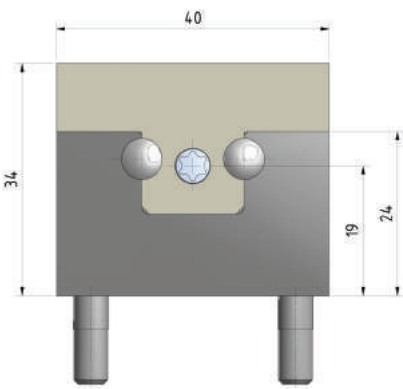
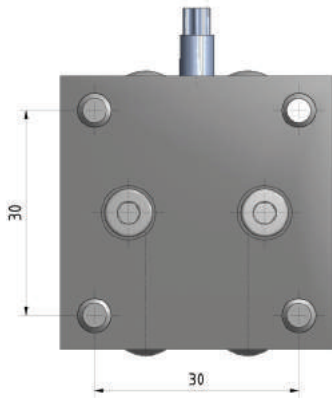

200-0040-001

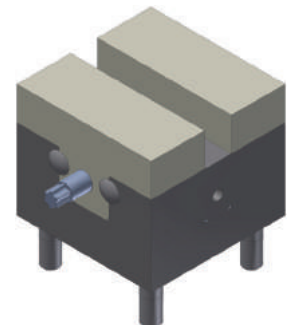
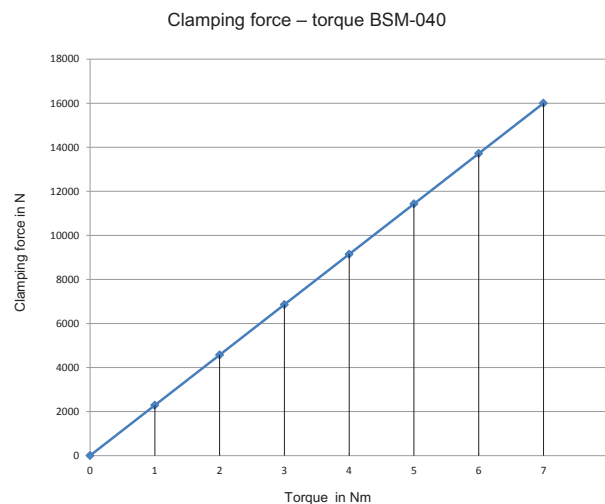
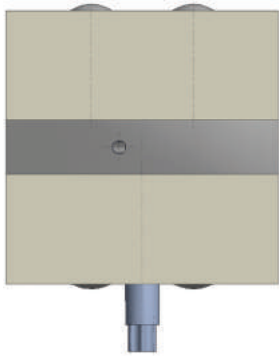

200-0040-002

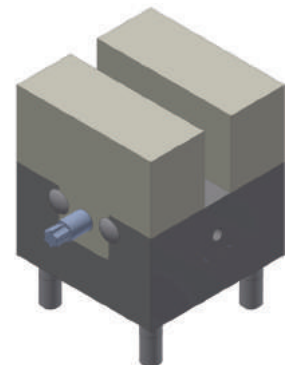

200-0040-003

Application area:

Especially for the processing of small, precise workpieces with mould jaws, such as e.g. in the watch industry or medical technology.

1.3.2 BSM-040 with grip jaws

Technical data:

Order number:	200-0040-004	200-0040-005	200-0040-006
Designation:	BSM-040	BSM-040	BSM-040
Dimensions (LxWxH):	40 x 40 x 32 mm	40 x 40 x 32 mm	40 x 40 x 32 mm
Weight:	about 500 g	about 500 g	about 500 g
Clamping range:	3–13 mm	12–22 mm	21–31 mm
Stroke per jaw:	5 mm	5 mm	5 mm
Max. torque:	7 Nm	7 Nm	7 Nm
Max. clamping force:	16 kN	16 kN	16 kN
Repeat accuracy:	+/- 0.02 mm		
Jaw connection:	Clamping jaws screwed onto spindle		

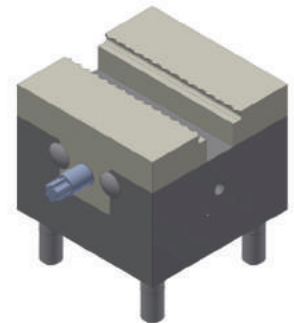
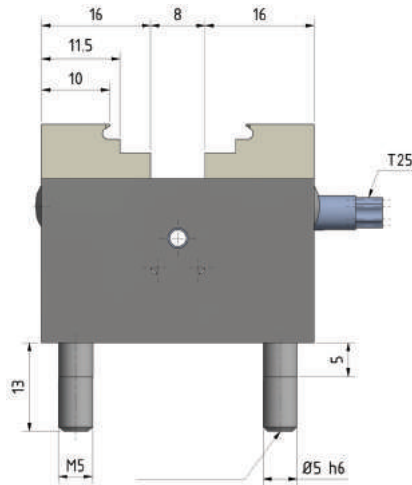
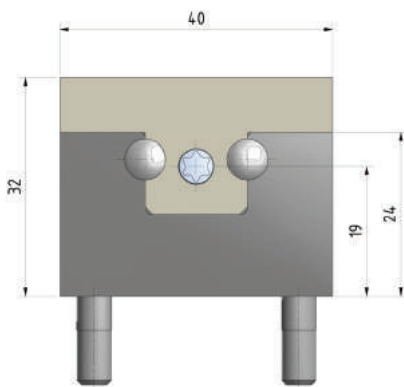
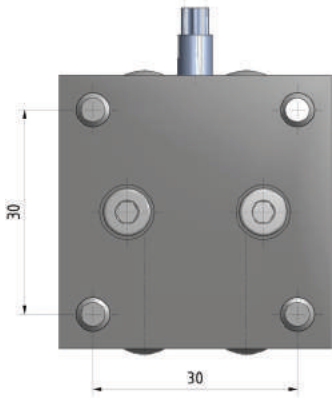

200-0040-005

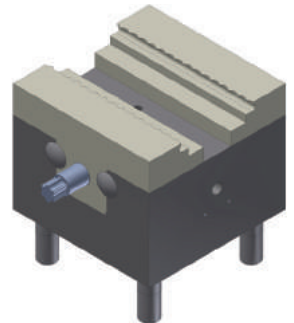

200-0040-004

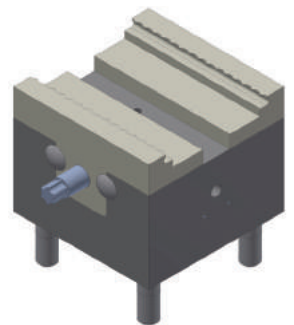

200-0040-006

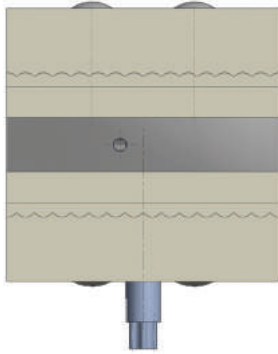

Clamping force – torque BSM-040

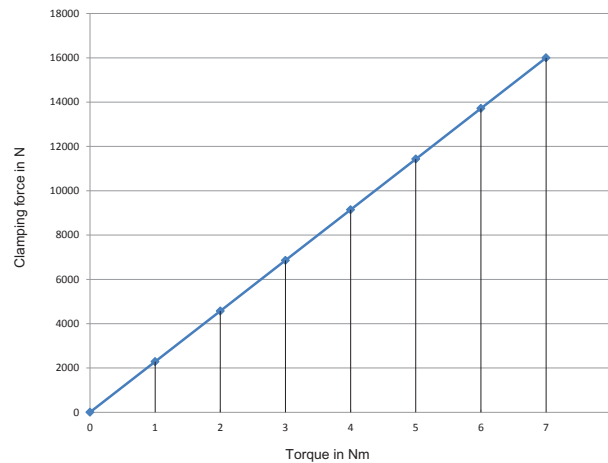

Application area:

Especially for the processing of blanks or finishing of small, precise workpieces, such as e.g. in the watch industry or medical technology.

1.3.3 5-axis clamping jaw for miniature vices

Features:

- Material: Aluminium, thus very light empty weight
- Optimised utilisation of the 5-axis machine
- Very good accessibility for the processing of the workpieces due to offset arrangement of the miniature vice and 45° arrangement of the upper vice

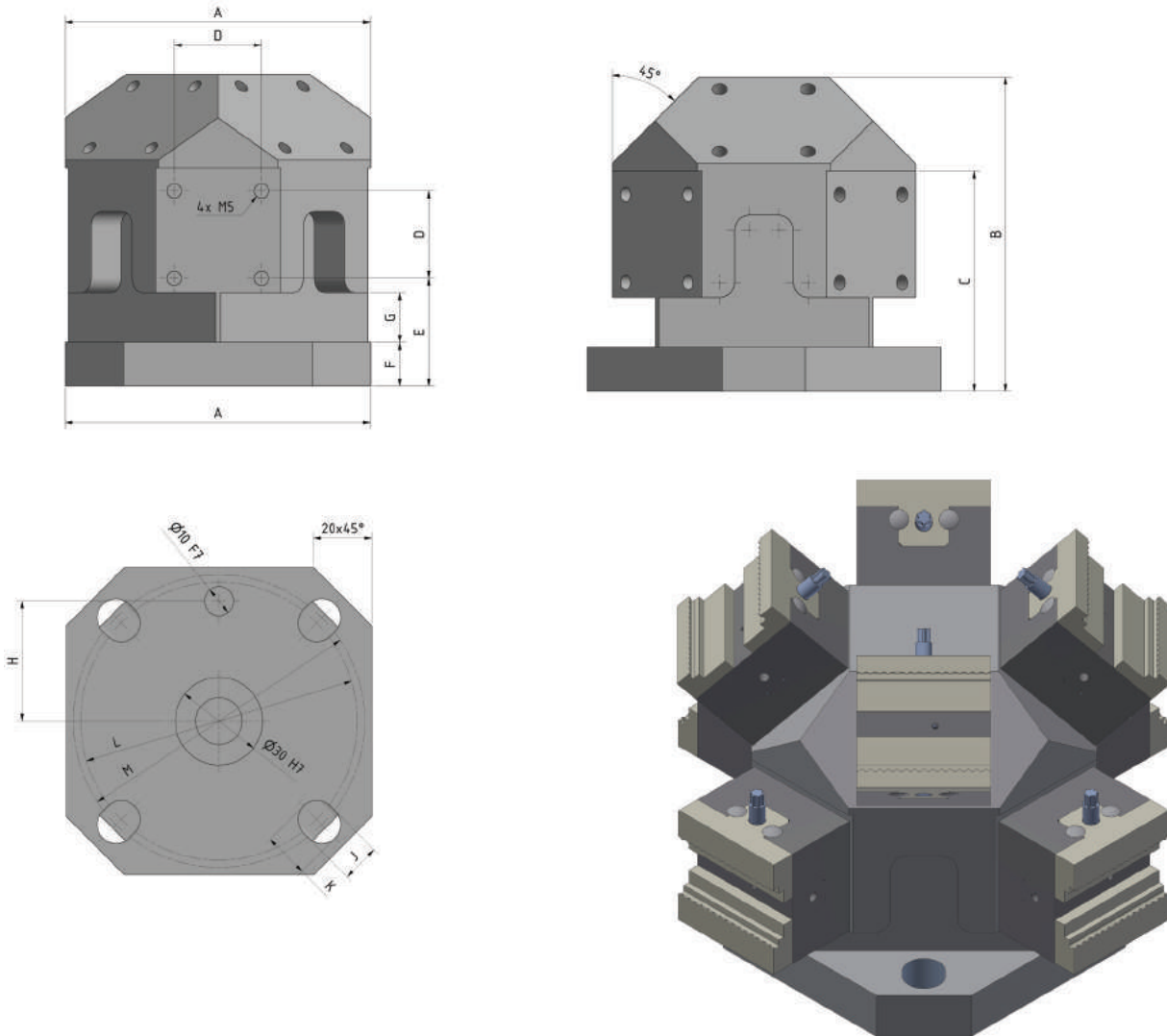

Table of dimensions:

Order number:	Designation	A mm	B mm	C mm	D mm	E mm	F mm	G mm	H mm	J mm	K mm	L mm	M mm
250-0105-001	B5S100-8	105	107	75	30	37	15	17	41	13	15.5	Ø 95	Ø 100

You can find the matching miniature vices to the 5-axis clamping jaw on pages 20 and 21; they are not included in the scope of supply for this 5-axis clamping jaw.

5-axis clamping jaws for miniature vices in other materials (e.g. steel), heights and forms are available on request.

1.4 Special solutions

If you are interested in one of the following special solutions or if you have a different special application, we would be delighted to hear from you.

After you have given us the specific data for your application, we will send you a technical draft together with an offer for the number of items you require.

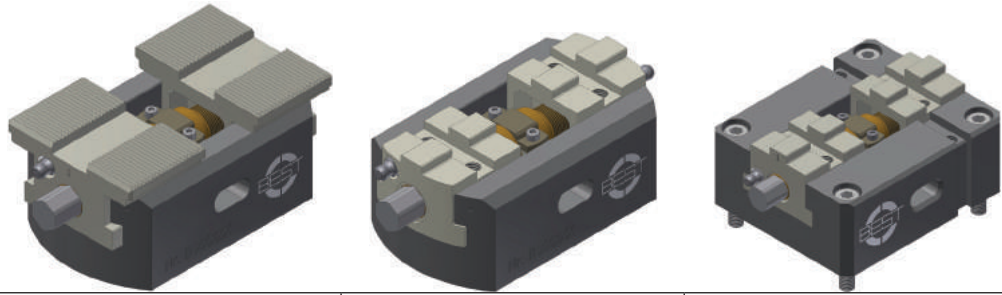

Order number:	200-0115-010	200-0115-011	210-0115-004
Designation:	BSM-115 quick-change	BSM-115 tongue and groove	BSM-115 tongue and groove

These centric vices are variants of standard model BSM-115.

The technical data for these variants are analogue to the standard models (see p. 7 and 8).

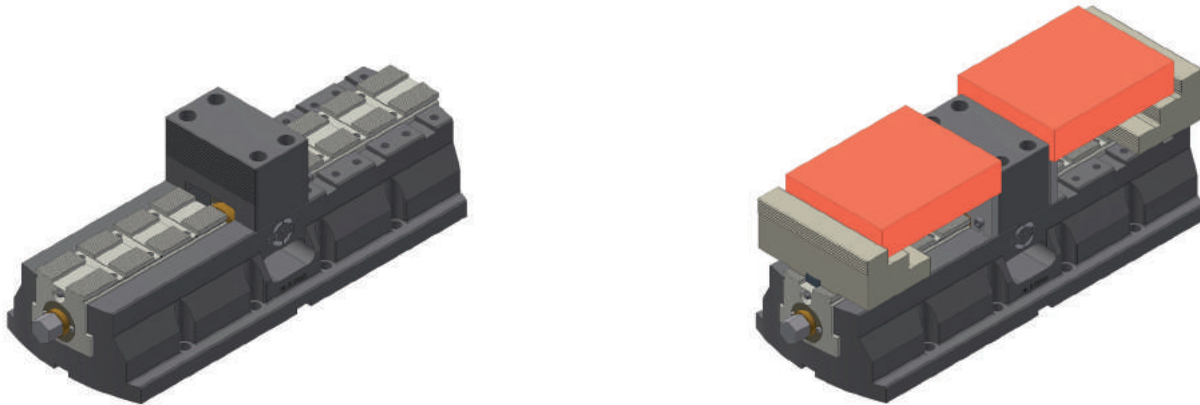

Order number:	200-0500-020
Designation:	BSM-500 double vice

The centric vice BSM-500 (see page 12) can be modified to allow two workpieces to be clamped. Play on the spindle bearing allows compensation of dimensional deviations between the two clamped workpieces. The attachment of a fixed jaw in the centre allows two identical parts to be clamped at the same time.

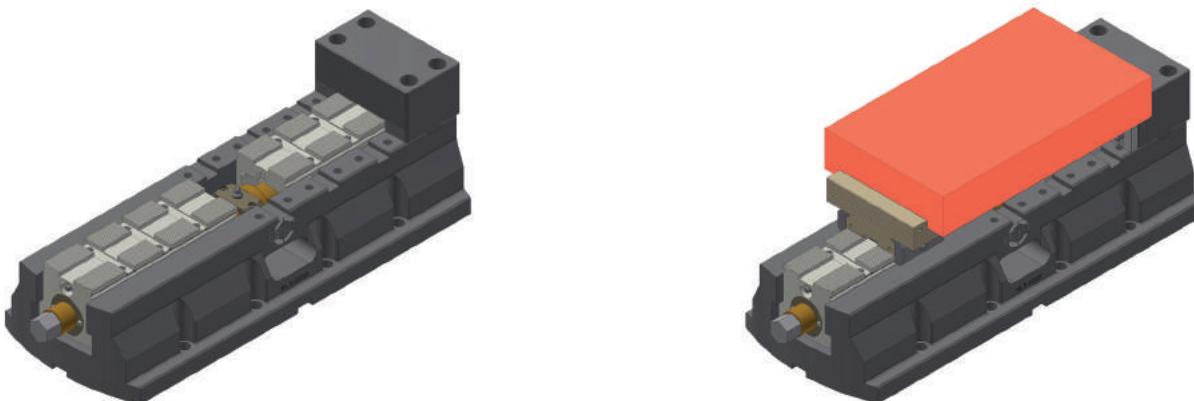

Order number:	200-0500-025
Designation:	BSM-500 with fixed jaw or as a centric vice

The BSM-500 centric vice (see page 12) can be modified so that it can be operated either as a centric vice or with a fixed jaw. The position of the fixed jaw can be freely selected.

1.5 Sample applications

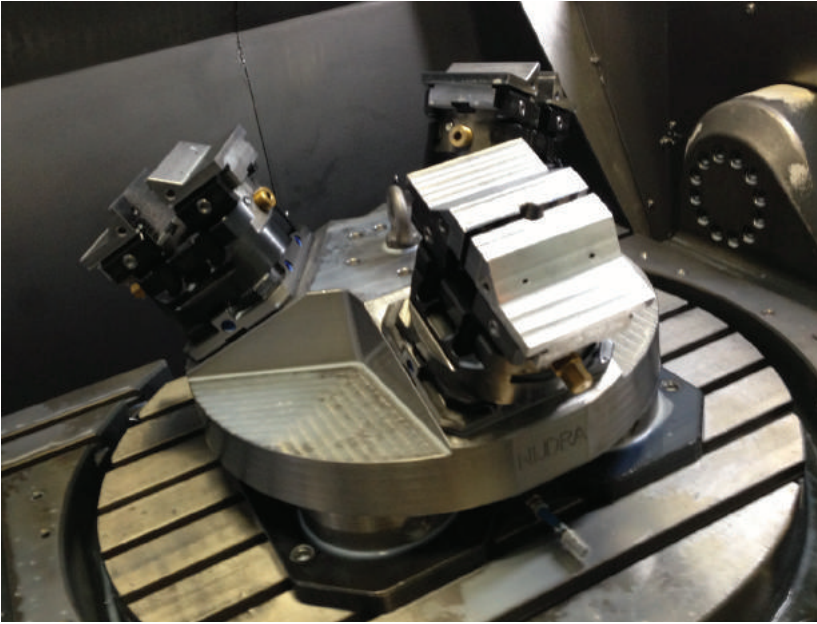

3 BSM-140 vices with mould jaws on LANG zero-point plate. The customer-specific device is clamped on Schunk zero-point clamping heads.

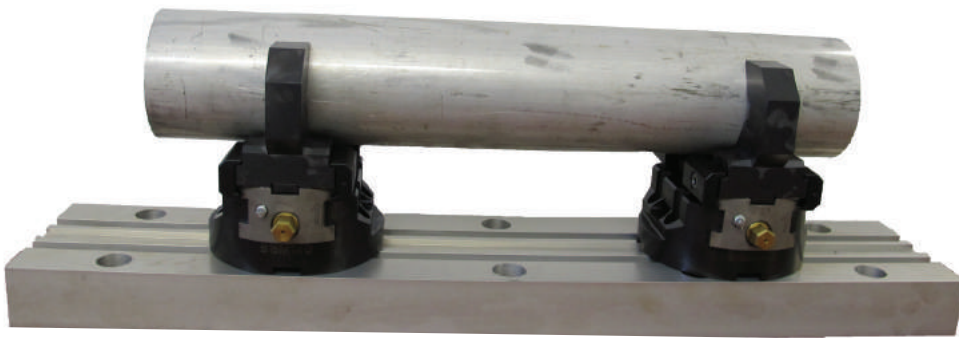

2 BSM-140 vices with prism jaws clamping a shaft. The clamps can be moved on the baseplate as required. Shafts with different lengths and diameters can thus be clamped.

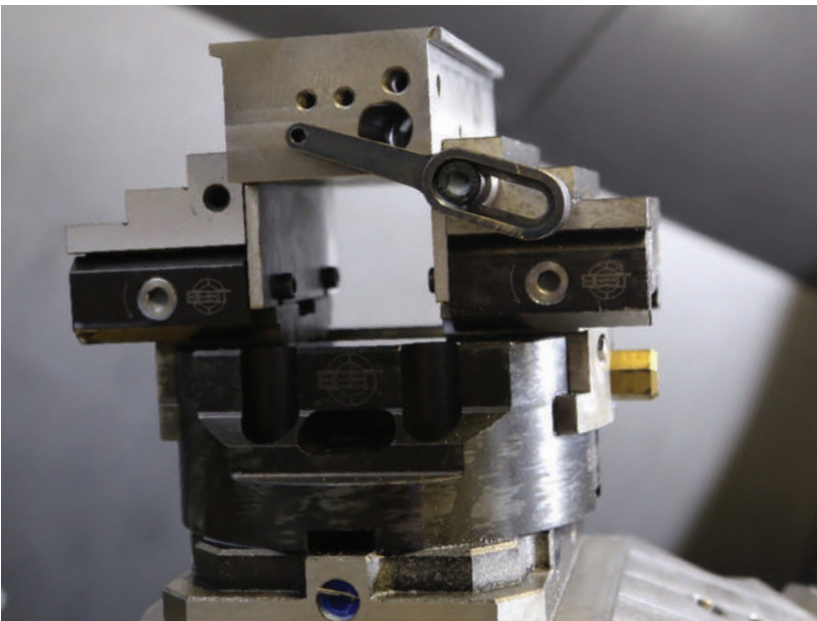

BSMG-140 with stepped jaws. A workpiece which is positioned on parallel bases is clamped. The position is defined by means of a side stop.

BSM-500 with protruding jaws for the clamping of workpieces up to 636 mm.



BSM-140 on EROWA zero point system ITS148.
A workpiece is clamped with mould jaws at 100 mm height.

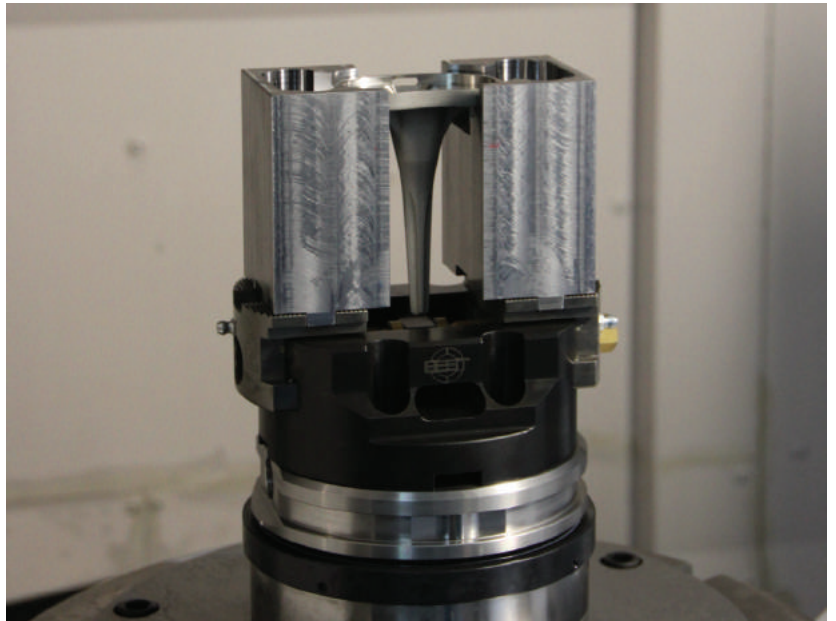

BSM-500 on double bracket with Vario jaws.
It is possible to clamp cubic as well as cylindrical workpieces featuring different sizes and diameters.

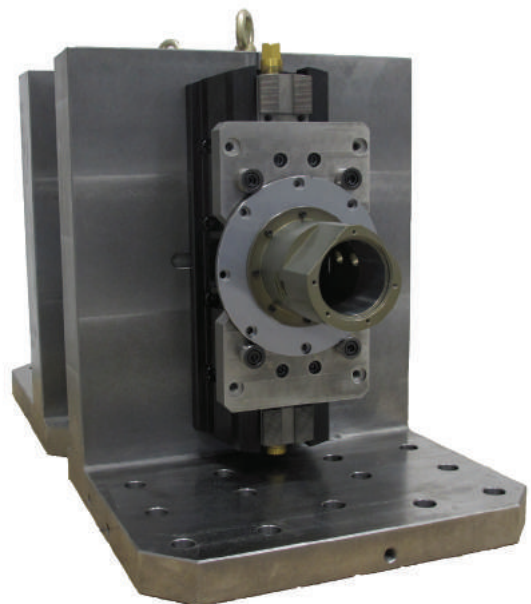

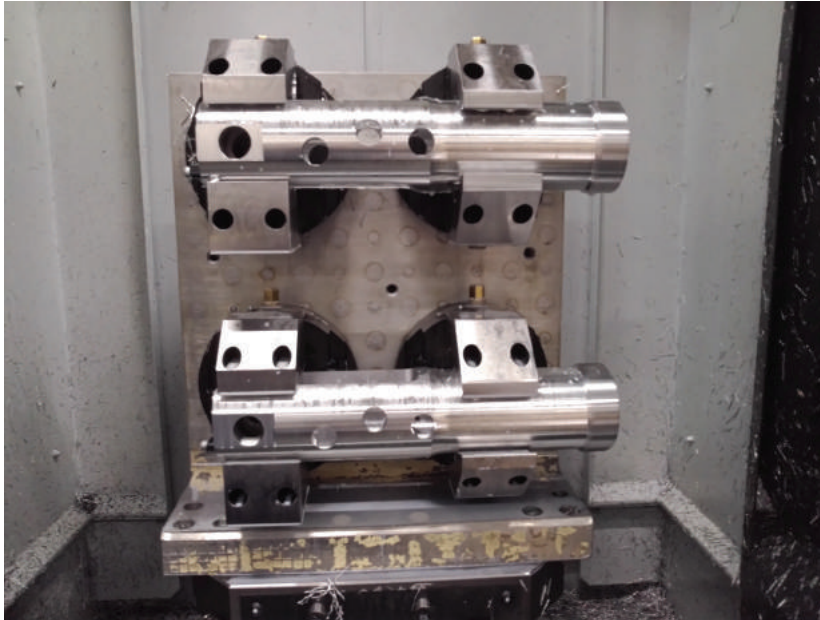

4-piece BSM-140 on bracket with prism jaw. 2 vices clamp a workpiece horizontally (OP10).

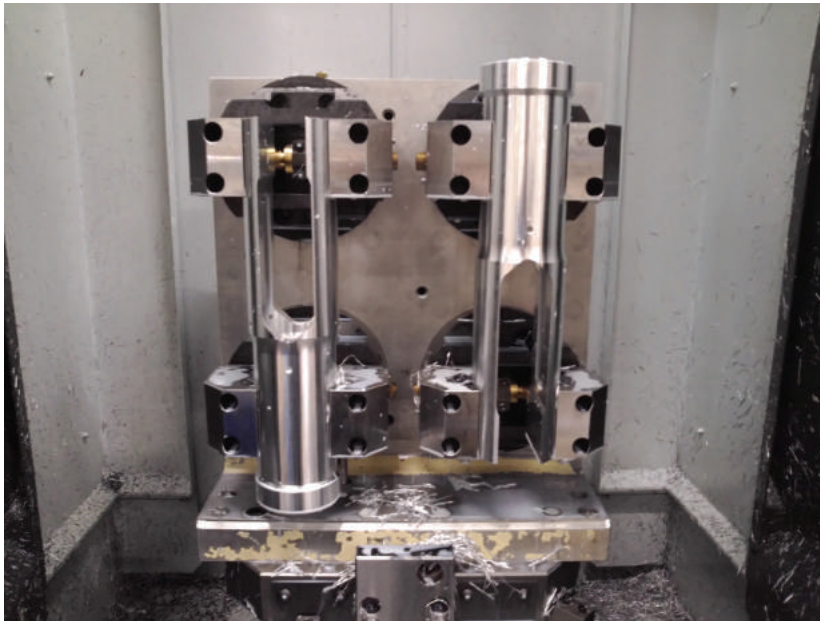

The vices BSM-140 are rotated by 90° and now clamp the workpiece vertically (OP20).

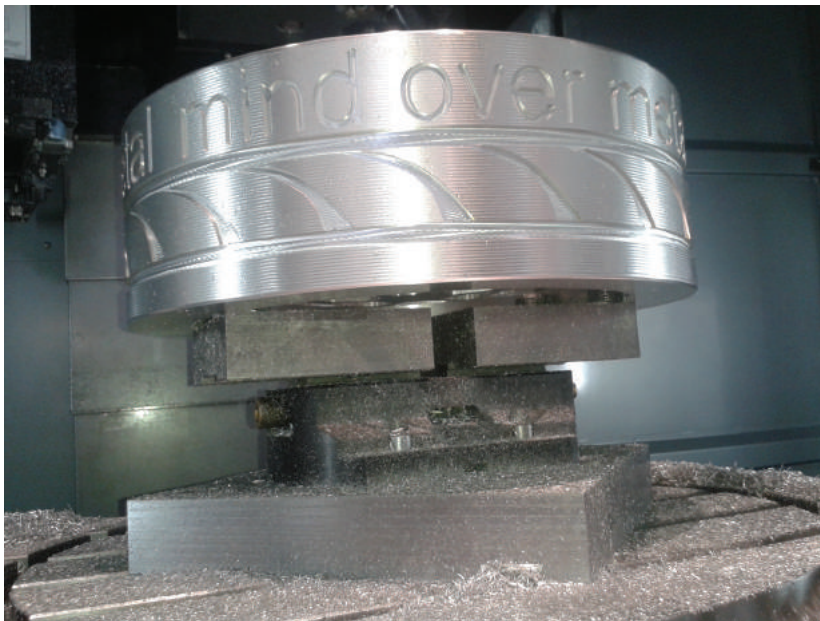

BSM-250 with Vario jaw. Shown clamping a demonstration workpiece on a HURCO processing centre from the inside to the outside.

BSM-180 with customer-specific grip jaws, which the customer manufactured from the blank jaws 300-0094-002.

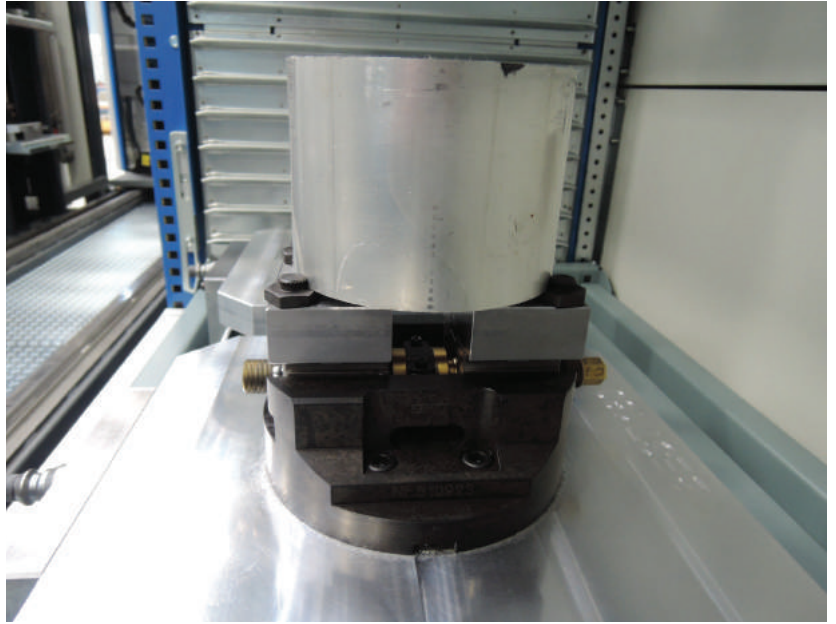

BSM-250 on Kitagawa rotary table GT250. Shown clamping a blank part with grip jaws.

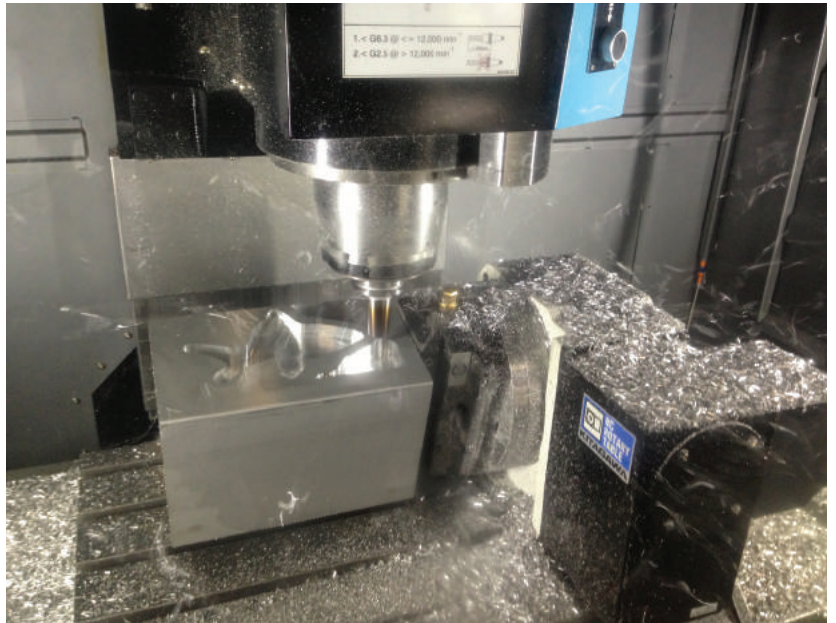

BSM-140 with mould jaws (customer-specific) for the clamping of a turning piece with 35 mm diameter.



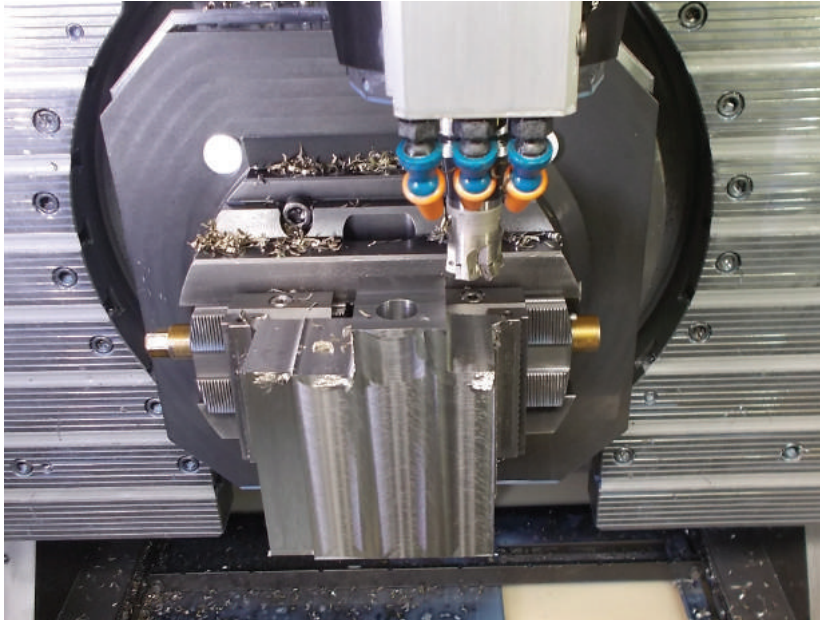

BSM-250 with the jaws 300-0094-006 for the processing of blanks on a 5-axis machine.



BSM-500 as Lynette. The workpiece is clamped with a 3-jaw chuck; the centric vice is purely used for clamping support.



The BSMG-500 vice is operated automatically. A robot inserts the workpiece and operates the threaded spindle with an impact wrench for clamping with a vice.

BSM-180 with prism jaws
301-0120-003 (see page 36).
By means of the 3 prisms, shafts
of \varnothing 19–116 mm can be clamped
with one set of jaws.

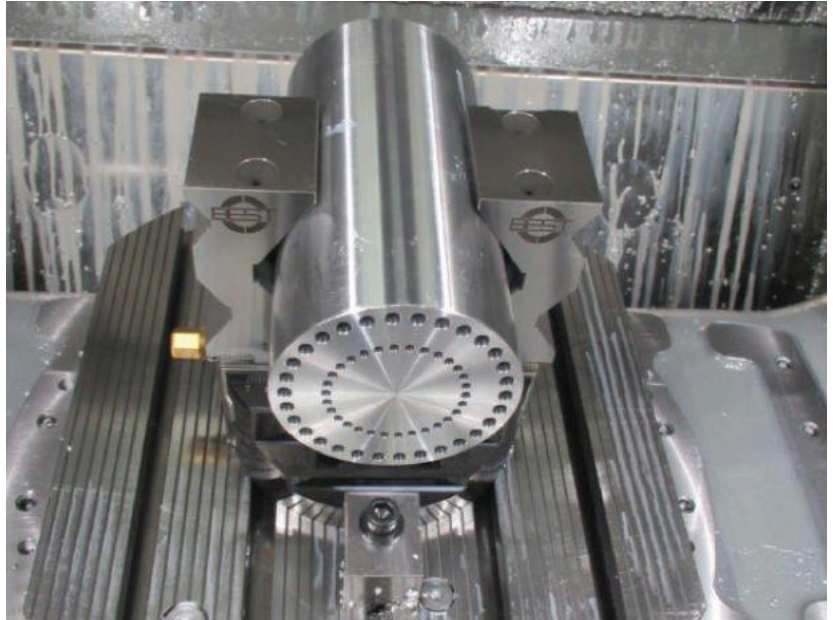

BSM-500 with high, chamfered jaw
for better accessibility
with 5-axis processing.

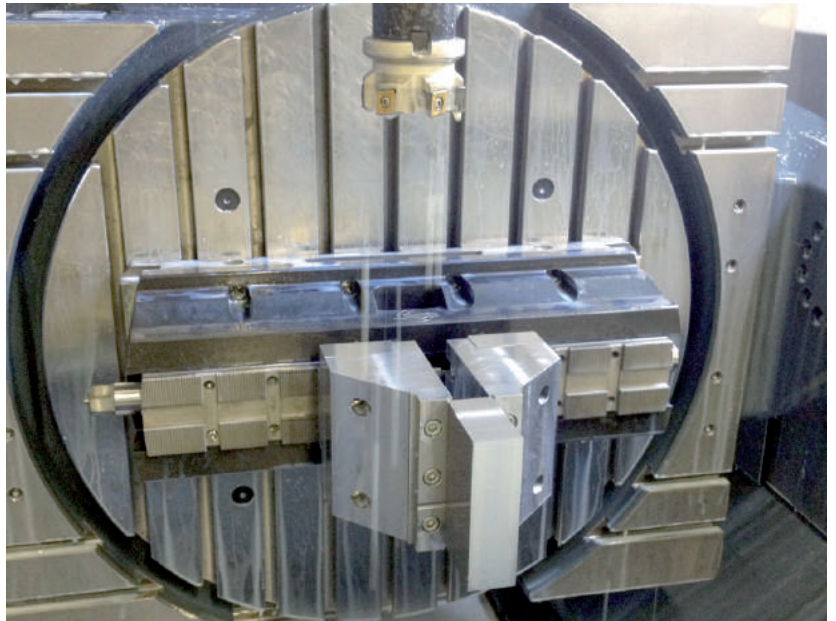

BSM-250 on riser for optimal
accessibility with 5-axis
processing.



2. Jaw range

2.1 Quick-change jaws

The quick-change jaws fit all vices with a quick-change jaw connection.

The jaws are tightened via a screw on the side (max. 25 Nm).

You can find dimension sheets for the quick-change jaws at www.best-spanntechnik.de.

2.1.1 Jaw blanks

Steel jaw blanks (with quick-change connection):

Order number:	Dimensions (WxLxH)
300-0094-002	94 x 60 x 49 mm
300-0125-001	125 x 60 x 49 mm
300-0150-001	150 x 60 x 49 mm

Material: 40 CrMnMo7

Application:
For in-house production of mould jaws.

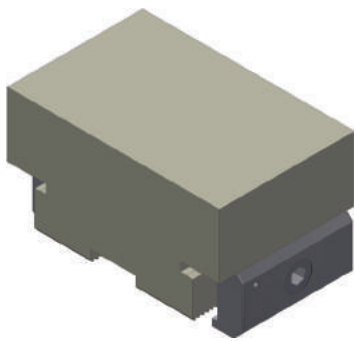

300-0094-002

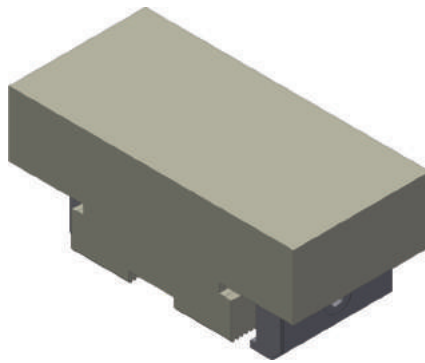

300-0125-001

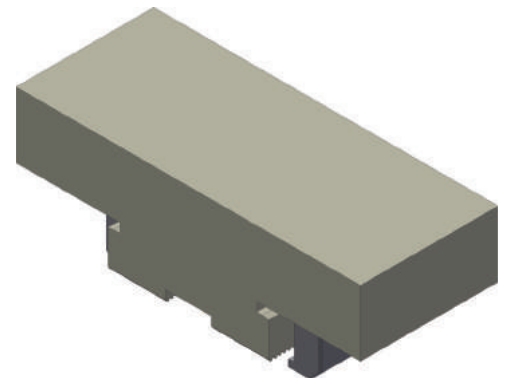

300-0150-001

Aluminium jaw blanks (with quick-change connection):

Order number:	Dimensions (WxLxH)
310-0094-001	94 x 60 x 49 mm
310-0125-001	125 x 60 x 49 mm
310-0150-001	150 x 60 x 49 mm

Material: AlZnMgCu0.5

Application:
For in-house production of mould jaws.

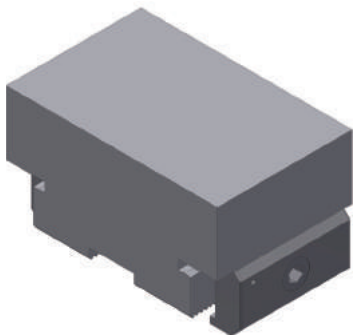

310-0094-001

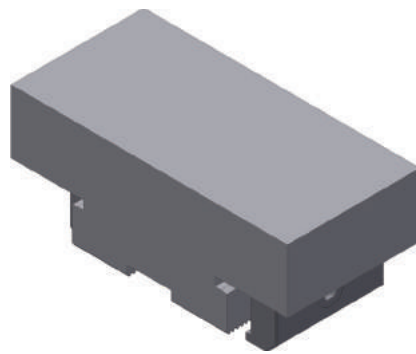

310-0125-001

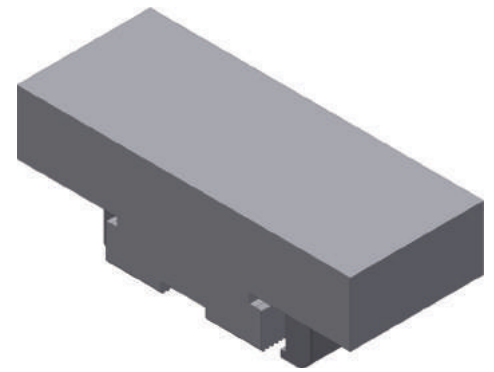

310-0150-001

2.1.2 Stepped jaws

Stepped jaws, hard (with quick-change connection):

Order number:	Dimensions (WxLxH)
300-0065-001	65 x 60 x 49 mm 3 levels: each 20 x 10 (LxH)
300-0094-007	94 x 60 x 49 mm 3 levels: each 20 x 10 (LxH)
300-0125-003	125 x 60 x 49 mm 3 levels: each 20 x 10 (LxH)
300-0061-003	61 x 50 x 35 mm 1 level: 4 x 5 (LxH)

The stepped jaws are hardened. The accuracy of the clamping surface relative to the serration is +/- 0.02 mm. For higher precision, the jaws must be ground out on the vice under clamping pressure.

Application:

For clamping workpieces which must not suffer damage. The clamping surface is grooved and not serrated. This provides optimum protection when clamping machined workpieces.

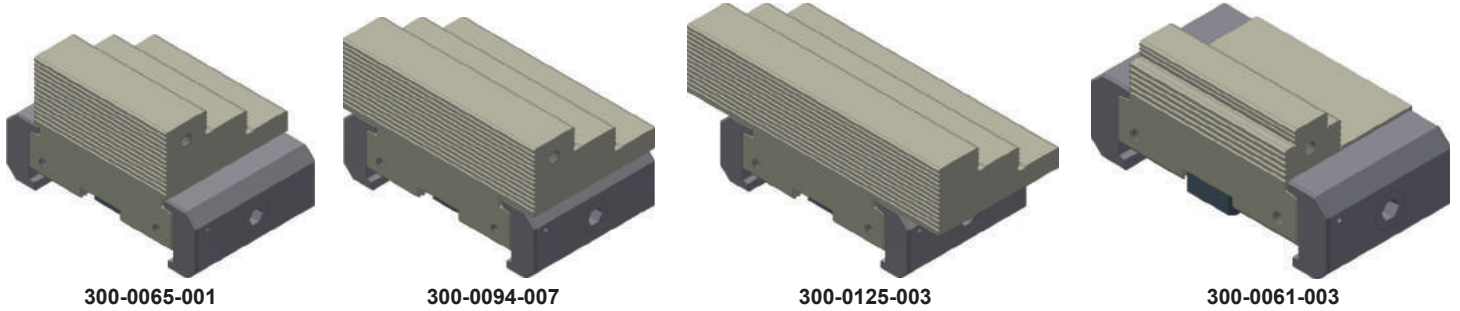

2.1.3 Grip jaws

Grip jaws with grip bar (quick-change connection):

Order number:	Dimensions (WxLxH)
300-0094-006	94 x 60 x 34 mm
300-0048-001	48 x 60 x 34 mm

The grip jaw is hardened, and the grip bar grips at a height of 3 mm. The accuracy of the clamping surface relative to the serration is +/- 0.05 mm.

Application:

For clamping raw materials under even concentrated load, in particular aluminium, where high surface pressure and thus maximum holding force are expected.

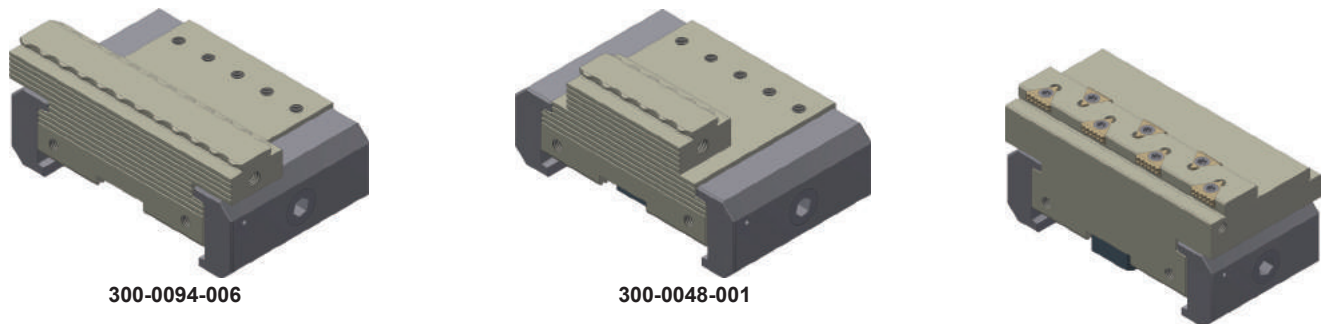

Grip jaws with master grip inserts (quick-change connection):

300-0094-017 (see below)

Order number:	Dimensions (WxLxH)
300-0094-017	94 x 50 x 40 mm

The grip jaws are hardened. These grip jaws have Mastergrip clamping claws fitted on each side of the clamping step. These claws grip at a height of 5 mm. The standard design features the inserts 6301-0010-001 (see page 38).

Application:

For the clamping of various materials for which three different optional clamping inserts are available. The engagement of the teeth produces a high surface pressure and maximum holding forces. If they become worn, the Mastergrip clamping claws can be replaced quickly and easily (see Spare parts, Page 38). At the same time, these jaws have a smooth side for clamping machined surfaces.

(associated image, see above.)

2.1.4 Pendulum grip jaws

Pendulum jaws with KonGrip clamping claws (quick-change connection):

Order number:	Dimensions (WxLxH)
300-0094-010	94 x 50 x 49 mm

These pendulum jaws have two KonGrip clamping claws hardened to 52-54 HRC fitted on each side of the clamping step. These claws grip at a height of 5 mm.

Application:
The pendulum jaw set consists of one fixed and one pendulum jaw. This allows workpieces with two non-parallel sides to be clamped with the pendulum jaw set (up to a bevel of 5°). The KonGrip clamping claws make the jaw set particularly suitable for rough machining. The engagement of the teeth produces a high surface pressure and maximum holding forces. Should the KonGrip clamping claws become worn, they can simply be replaced with new ones. At the same time, the jaw set also has two smooth sides for clamping machined surfaces.

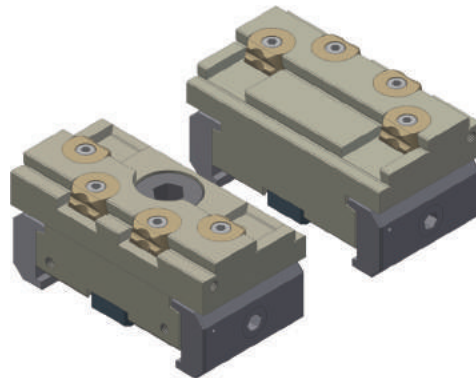

300-0094-010

2.1.5 Prism jaws

Prism jaws (with quick-change connection):

(Please inquire with us, and we will prepare an individual offer for you)

Order number:	Dimensions (WxLxH)
-	on request

The prism jaws with quick-change jaw connection can be used to clamp a wide variety of shafts with diameters ranging from 5 mm to 120 mm.

With these jaws, work can be performed without problems both on the end face (e.g. planing, drilling, thread cutting) and the long side (e.g. milling precisely centred pockets).

Let us know the diameters of the shafts you need to clamp, and we will inform you which prismatic clamping jaws you require for the desired diameters.

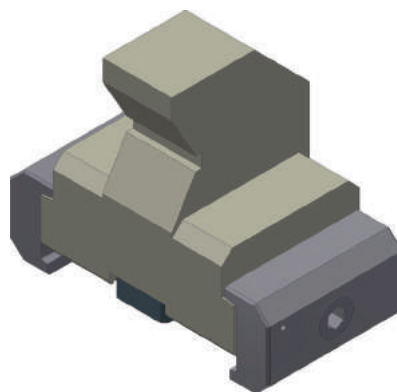

Additional customer-specific special jaws can be supplied on request. Please provide us with the specific data for your application, and we will gladly send you a technical draft together with an offer for the number of items you require.

2.2 Tongue and groove jaws

The tongue and groove jaws **fit specific vice models in each case (see table below)**.

If you need one of the jaws listed for a different vice, contact us for details. You can find dimension sheets for the tongue and groove jaws at www.best-spanntechnik.de.

2.2.1 Jaw blanks

Steel jaw blanks (tongue and groove connection):

Order number:	Fits vice model:	Dimensions (WxLxH)
301-0065-001	BSM-115-KV (see p. 6)	65 x 50 x 45 mm
301-0094-002	BSM-140 (see p. 7)	94 x 60 x 50 mm
301-0125-002	BSM-180 (see p. 8)	125 x 60 x 50 mm
301-0150-001	BSM-250 + BSM-500 (see p. 9+10)	150 x 120 x 70 mm
301-0160-004	BSMG-500	160 x 183 x 80 mm

Material: 16 MnCr5

Application:
For in-house production of mould jaws and subsequent clamping of moulded parts where the workpiece surface must be free of clamping marks.

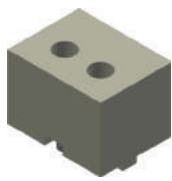

301-0065-001

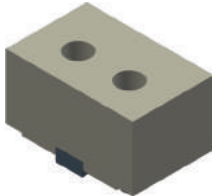

301-0094-002

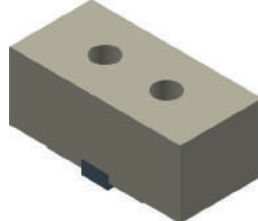

301-0125-002

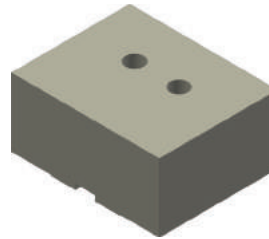

301-0150-001

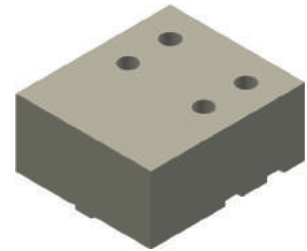

301-0160-004

Aluminium jaw blanks (tongue and groove connection):

Order number:	Fits vice model:	Dimensions (WxLxH)
311-0065-001	BSM-115-KV (see p. 6)	65 x 50 x 45 mm
311-0094-001	BSM-140 (see p. 7)	94 x 60 x 50 mm
311-0125-001	BSM-180 (see p. 8)	125 x 60 x 50 mm
311-0150-001	BSM-250 + BSM-500 (see p. 9+10)	150 x 120 x 70 mm

Material: high-strength aluminium

Application:
For in-house production of mould jaws and subsequent clamping of moulded parts where the workpiece surface must be free of clamping marks.

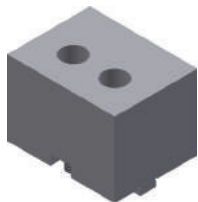

311-0065-001

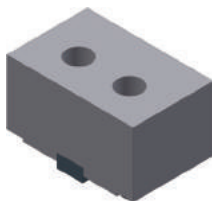

311-0094-001

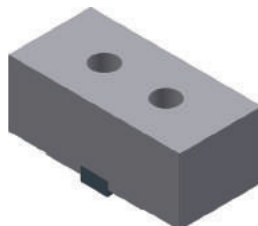

311-0125-001

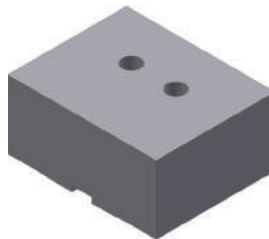

311-0150-001

2.2.2 Stepped jaws

Stepped jaws, hard (tongue and groove connection):

Order number:	Fits vice model:	Dimensions (WxLxH)	Clamping range:
301-0065-002	BSM-115-KV (see p. 6)	65 x 45 x 32 mm 3 levels: each 15 x 8 (LxH)	4-92 mm
301-0070-003	BSM-140 (see p. 7)	70 x 60 x 42 mm 3 levels: each 20 x 10 (LxH)	2-130 mm
301-0094-003	BSM-180 (see p. 8)	94 x 70 x 42 mm 3 levels: each 25 x 10 (LxH)	4-172 mm
301-0125-003	BSM-250 + BSM-500 (see p. 9+10)	125 x 95 x 42 mm 3 levels: each 35 x 10 (LxH)	BSM 250: 2-210 mm BSM 500: 2-456 mm
301-0160-001	BSM-250 + BSM-500 (see p. 9+10)	160 x 93 x 65 mm 3 levels: each 31 x 20 (LxH)	BSM 250: 2-194 mm BSM 500: 2-440 mm
301-0160-003	BSMG-500 (see p. 15)	160 x 151.2 x 55 mm 3 levels: each 60 x 15 (LxH)	2-490 mm

The stepped jaws are hardened. For high precision, the jaws must be ground out on the vice under clamping pressure.

Application:

For clamping workpieces which must not suffer damage. The clamping surface is grooved and not serrated. This provides optimum protection when clamping machined workpieces.

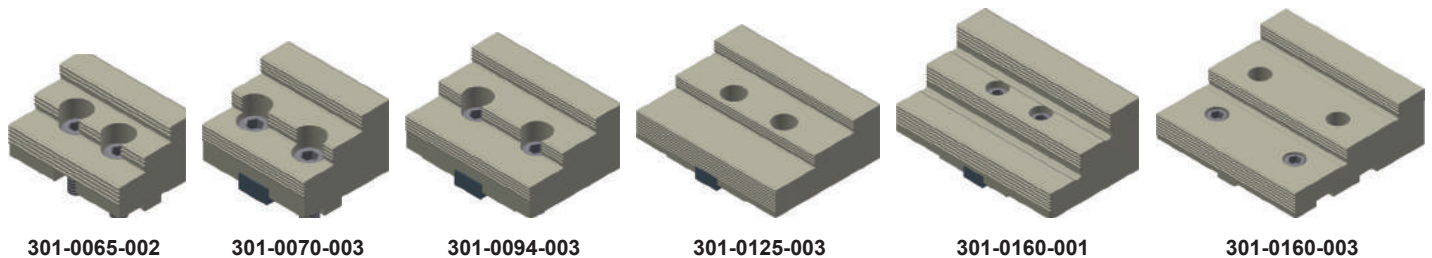

2.2.3 Grip jaws

Grip jaws with grip bar (tongue and groove connection):

Order number:	Fits vice model:	Dimensions (WxLxH)	Clamping range:
301-0065-005	BSM-115-KV	65 x 40 x 26 mm	10-70 mm
301-0094-006	BSM-140 (see p. 7)	94 x 40 x 34 mm	10-95 mm
301-0094-004	BSM-180 (see p. 8)	94 x 50 x 34 mm	12-78 mm ; 90-157 mm

The grip jaws are hardened.

The grip bar grips at a height of 3 mm.

Application:

For clamping raw materials under even concentrated load, in particular aluminium, where high surface pressure and thus maximum holding force are expected.

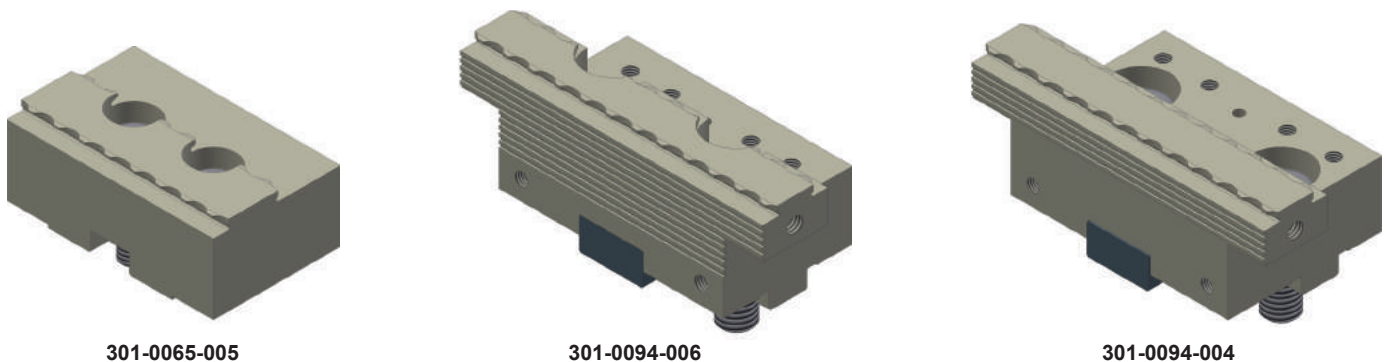

Grip jaws with master grip inserts (tongue and groove connection):

Order number:	Fits vice model:	Dimensions (WxLxH)	Clamping range:
301-0065-004	BSM-115	65 x 47.5 x 20 mm	8-52 mm
301-0094-012	BSM-140	94 x 50 x 34 mm	10-37 mm ; 60-107 mm
301-0094-011	BSM-180	94 x 50 x 40 mm	12-149 mm

Material: Nitro steel

Grip jaws are nitrogen-hardened to a depth of approx. 0.2 mm. These grip jaws have Mastergrip clamping claws fitted on each side of the clamping step. The standard design features the inserts 6301-0010-001 (see page 38).

Application:

For clamping sawing cuts, raw materials with a scaled surface and cast parts with the same concentrated load.

The engagement of the teeth produces a high surface pressure and maximum holding forces. If they become worn, the Mastergrip clamping claws can be replaced quickly and easily (see Spare parts, Page 38).

At the same time, these jaws have a smooth side for clamping machined surfaces.

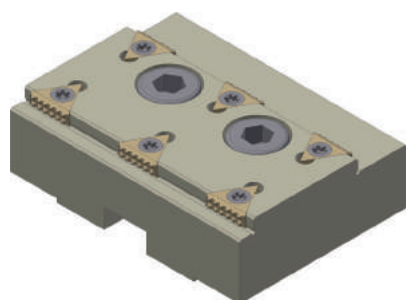

301-0065-004

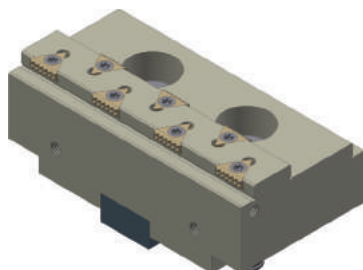

301-0094-012

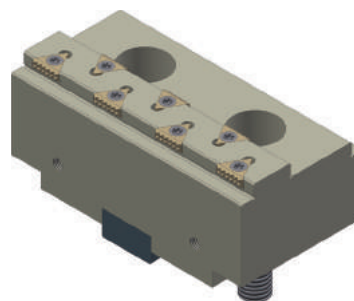

301-0094-011

2.2.4 5-axis jaws

5-axis jaws (tongue and groove connection):

(Please inquire with us, and we will prepare an individual offer for you)

Order number:	Fits vice model:	Dimensions (WxLxH)	Clamping range:
301-0100-013	BSM-180	100 x 69 x 65 mm	20-75 mm 80-150 mm
301-0100-012	BSM-250	100 x 95 x 95 mm	20-85 mm 135-200 mm
301-0125-014	BSM-500	125 x 120 x 120 mm	18-448 mm

The 5-axis jaws provides you with the optimal accessibility to your workpiece. We will be happy to match the jaws to your required clamping range.

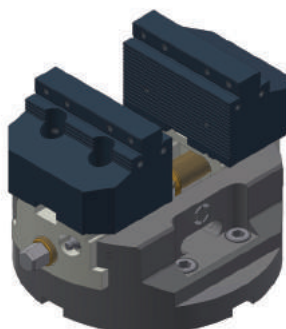

301-0100-013

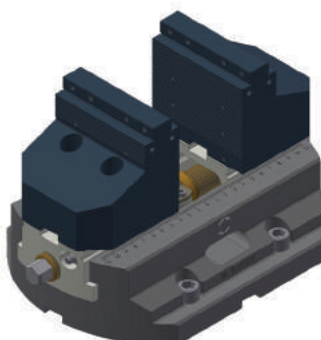

301-0100-012

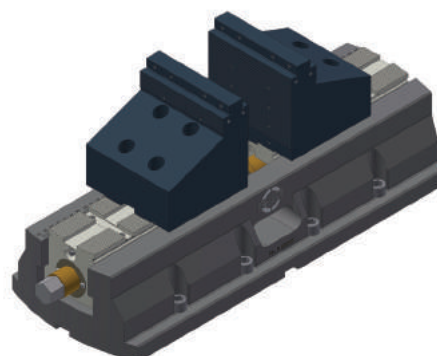

301-0125-014

2.2.5 Prism jaws

Prism jaws (tongue and groove connection):

(Please inquire with us, and we will prepare an individual offer for you)

Order number:	Fits vice model:	Dimensions (WxLxH)	Clamping range:
301-0120-003	BSM-180	70 x 60 x 110 mm	∅ 19-45 mm horizontal ∅ 30-70 mm horizontal ∅ 60-116 mm horizontal
301-0125-005	BSM-180	125 x 60 x 87 mm	∅ 45-95 mm horizontal
301-0250-004	BSM-250	70 x 80 x 105 mm	∅ 79-110 mm horizontal
301-0025-001	BSM-250	70 x 81 x 49 mm	∅ 25-40 mm vertical

The prism jaws with tongue and groove connection can be used to clamp shafts with diameters ranging from 5 mm to 300 mm.

With these jaws, work can be performed without problems both on the end face (e.g. planing, drilling, thread cutting) and the long side (e.g. milling precisely centred pockets).

Let us know the diameters of the shafts you need to clamp, and we will inform you which prismatic clamping jaws you require for the desired diameters.

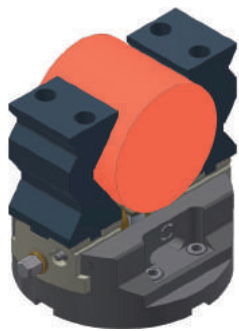

301-0120-003 (1)

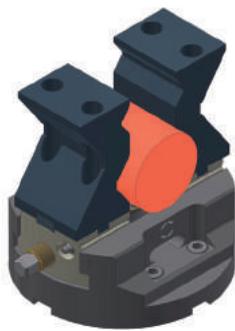

301-0120-003 (2)

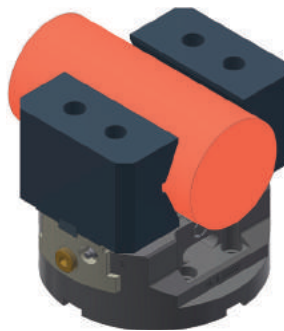

301-0125-005

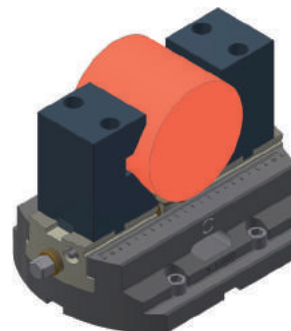

301-0250-004

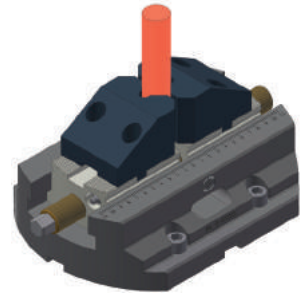

301-0025-001

Additional customer-specific special jaws can be supplied on request. Please provide us with the specific data for your application, and we will gladly send you a technical draft together with an offer for the number of items you require.

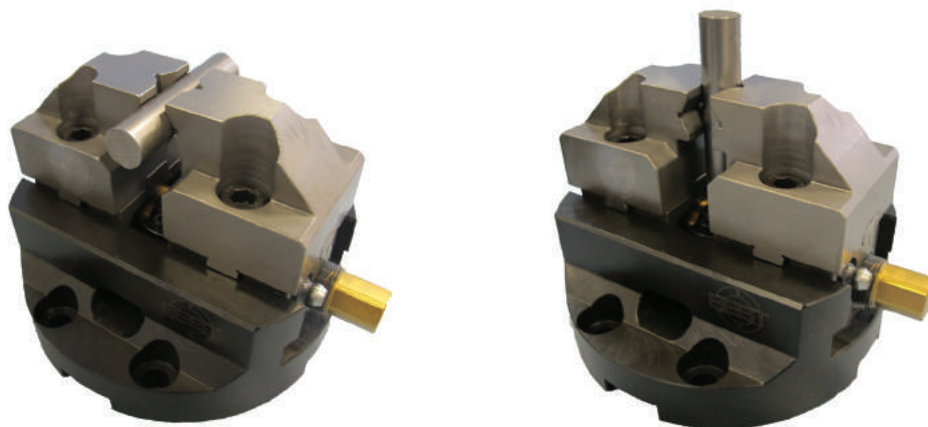

Special prism jaw 301-0020-001
for BSM-115-KV clamping range
6-20 mm horizontal and vertical

2.2.6 Vario jaws

Vario jaws with tongue and groove connection:

Order number:	Fits vice model:	Dimensions (WxLxH)	Clamping range:
303-0200-001	BSM-500	200 x 130 x 30 mm	□ 12-414 mm, ∅ 72-445 mm
303-0200-004	BSM-250 BSM-500	200 x 130 x 30 mm	□ 32-262 mm, ∅ 53-267 mm □ 32-510 mm, ∅ 53-516 mm

The Vario jaws can be used to clamp cylindrical and cubic workpieces.

The clamping inserts can be positioned at various points on the jaw, allowing clamping of a wide range of parts with one jaw set.

Both raw parts and workpieces for finishing can be clamped by changing the clamping inserts. When ordering jaws, please state the application for which you require them.

The clamping inserts must be ordered separately (see page 38).
Additional possible upon request.

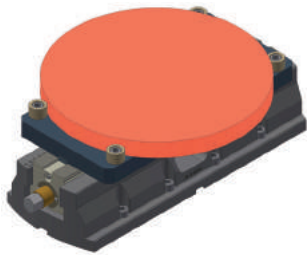

303-0200-001

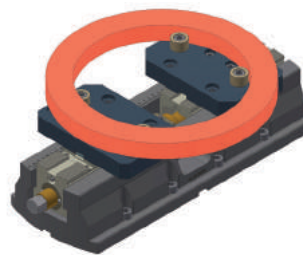

303-0200-001

Vario jaws with tongue and groove connection (one pendulum jaw):

Order number:	Fits vice model:	Dimensions (WxLxH)	Clamping range:
303-0160-001	BSM-180	160 x 86 x 22 mm	□ 8-180 mm, ∅ 116-216 mm
303-0160-002	BSM-250 BSM-500	160 x 101 x 22 mm	□ 14-205 mm, ∅ 130-263 mm □ 14-450 mm, ∅ 116-466 mm

The Vario jaws can be used to clamp cylindrical and cubic workpieces. One jaw is designed as pendulum, for this reason nonparallel workpieces can not be clamped.

The clamping inserts can be positioned at various points on the jaw, allowing clamping of a wide range of parts with one jaw set.

By changing the clamping inserts, blanks as well as workpieces for finishing can be clamped. When ordering jaws, please state the application for which you require them.

The clamping inserts must be ordered separately (see page 38).
Additional possible upon request.

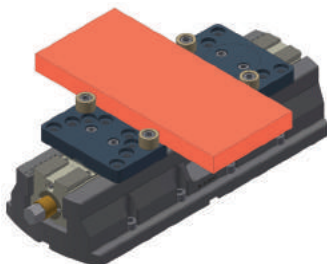

303-0160-001

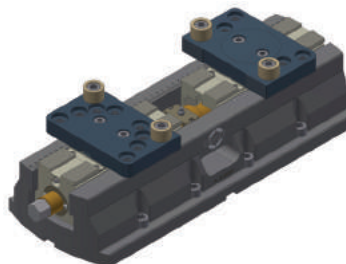

303-0160-002

Additional customer-specific special jaws can be supplied on request. Please provide us with the specific data for your application, and we will gladly send you a technical draft together with an offer for the number of items you require.

2.3 Spare parts and accessories



5222-0020-001

Clamping claws:

Order number:	Designation
5222-0020-001	Clamping claw
Spare parts match jaws 300-0094-010 (see page 32).	

Mastergrips clamping inserts:

Order number:	Designation
6301-0010-001	Mastergrip inserts for steel
6301-0010-002	Mastergrip inserts for hardened steel (up to 50-54 HRC) and titanium
6301-0010-003	Mastergrip inserts for aluminium
Spare parts matching jaws 300-0094-017 (see page 32) and 301-0065-004, 301-0094-011 and 301-0094-012 (see page 35).	

Vario clamping inserts:

Order number:	Designation
6304-0029-001	Smooth clamping insert for Vario jaws Dimensions: 29 x 24 mm (diam. x H)
6304-0029-002	Gripper clamping insert for Vario jaws Dimensions: 29 x 24 mm (diam. x H)
6304-0029-003	Smooth clamping insert for Vario jaws Dimensions: 29 x 11 mm (diam. x H)
6304-0029-004	Gripper clamping insert for Vario jaws Dimensions: 29 x 11 mm (diam. x H)
6304-0029-005	Smooth clamping insert for Vario jaws Dimensions: 29 x 19 mm (diam. x H)
6304-0029-006	Gripper clamping insert for Vario jaws Dimensions: 29 x 19 mm (diam. x H)
6304-0029-007	Gripper clamping insert for Vario jaws Dimensions: 29 x 35 mm (diam. x H)

Fits Vario jaws, see Page 37.

Also available in other sizes on request.

Magnetic connection points:

Order number:	A mm	B mm	C mm	Holding force:
5062-0020-001	92	10-80	Ø 20	45 N (~4.5 kg)
5062-0020-002	95	10-80	Ø 25	80 N (~8.0 kg)
5062-0020-003	95	11-80	24x47.5	120 N (~12.0 kg)

Adjustable point clamps:

Order number:	A mm	B mm	C mm	Holding force:
5062-0020-004	95	10-80	Ø 12	Mounted with M6

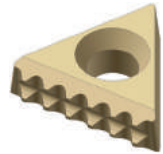

6301-0010-001

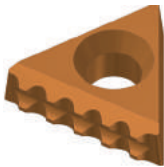

6301-0010-002

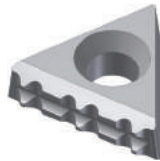

6301-0010-003



6304-0029-001



6304-0029-002



6304-0029-003



6304-0029-004

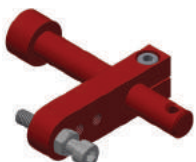

5062-0020-001

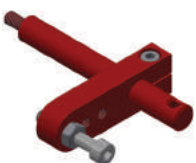
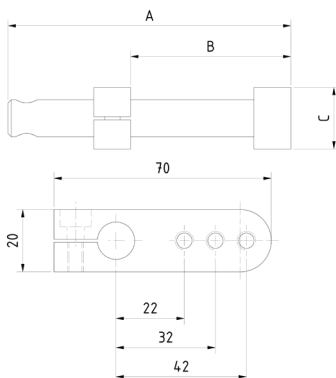

5062-0020-004

Spare parts quick-change system:

Order number:	Designation
5600-0050-001	Claw, left-hand thread, 50 mm wide
5600-0050-002	Claw, right-hand thread, 50 mm wide
5600-0060-001	Claw, left-hand thread, 60 mm wide
5600-0060-002	Claw, right-hand thread, 60 mm wide
5742-0014-001	Spindle for quick-change jaws
6904-0020-050	Feather key for quick-change jaws
Spare parts matches all quick-change jaws (see p. 30 to 32).	



Parallel bases:

Order number:	Height mm	Width (total) mm	Width (support) mm
6303-0047-001	20	69	47
6303-0047-002	24	69	47
6303-0047-003	29	69	47
6303-0047-004	31	69	47
6303-0047-005	34	69	47
6303-0047-006	39	69	47
6303-0047-007	44	69	47
6303-0047-008	46	69	47
6303-0060-001	20	69	60
6303-0060-002	24	69	60
6303-0060-003	29	69	60
6303-0060-004	31	69	60
6303-0093-001	14	94	93
6303-0093-002	20	94	93
6303-0093-003	24	94	93
6303-0093-004	29	94	93
6303-0093-005	31	94	93
6303-0093-006	34	94	93
6303-0093-007	39	94	93
6303-0093-008	44	94	93
6303-0093-009	46	94	93
6303-0093-010	47	94	93
Additional sizes available upon request.			

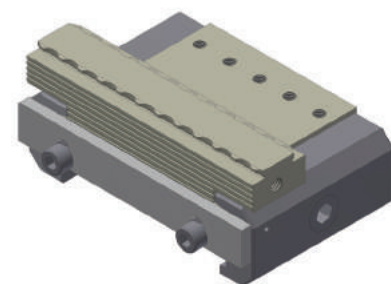
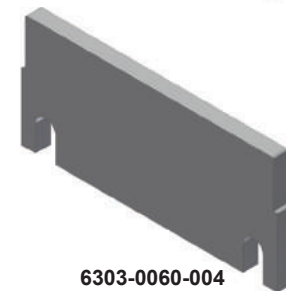
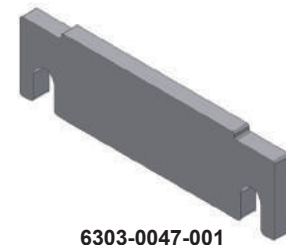

Application example: parallel bases

Magnetic pendulum jaws:

Order number:	Designation
6303-0094-001	Pendulum jaws
For clamping non-parallel workpieces Attaches magnetically to steel jaw Dimensions: 94 x 30 x 22 mm Version: tool steel / 62 Rockwell hardened	

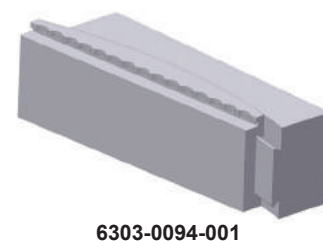

3. Zero point system

3.1 Realpoint zero-point clamping system

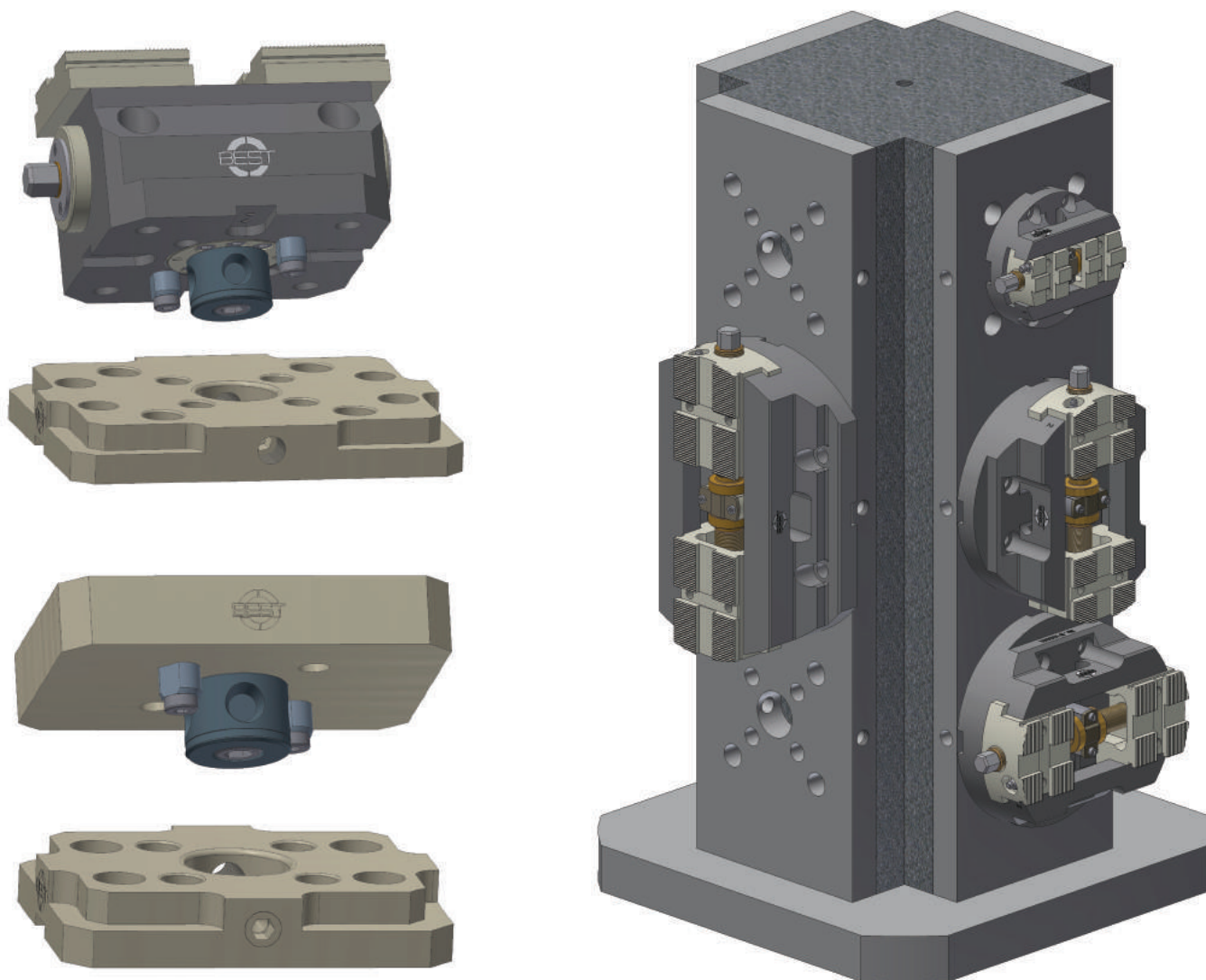

Advantages of the Realpoint zero-point clamping system:

- Modular system: all components in this product family are intercompatible and can be replaced quickly (centric vices, baseplates, quick-change jaws and tongue and groove jaws)
- The quick-change system reduces setup time (centric vice and pallets can be quickly replaced by means of the clamping screw fitted on the side)
- One-size tightening bolt for all models
- Extremely high pull-in forces (50 kN with the clamping screw tightened to 50 Nm)
- Pallets and centric vice can be indexed by 90°
- Extremely flat design of baseplates and pallets (27 mm)
- Can be easily integrated into cube, bar or special plate solutions for multi-axis machines
- Placed next to each other, the rectangular baseplates turn the machining table into a grid table
- Ideally suited for palletising of automated clamping solutions on machine tools
- Pallets can accommodate your equipment or existing clamping tools individually
- Existing zero-point clamping systems from other manufacturers can be easily adapted to our system

3.1.1 RPC / RPCG centric vices

Through the simple attachment of a tightening bolt and two alignment bolts (see page 47), BSM centric vices (from page 6) become RPC zero-point centric vices and encapsulated BSMG centric vices (from page 14) become encapsulated RPCG zero-point centric vices.

The centric vices can be ordered fully assembled in the zero-point version.

See the tables below for the order numbers of the individual zero-point versions.

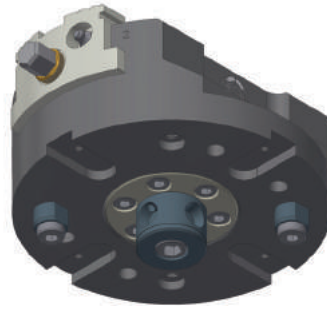
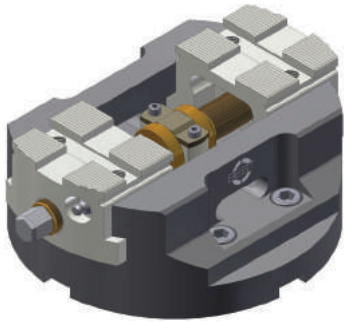

BSM...



becomes RPC:

Order number:	Designation
200-0115-012 (p. 7)	BSM-115-SWBA
200-0115-014 (p. 8)	BSM-115-KV
200-0140-010 (p. 9)	BSM-140
200-0180-010 (p. 10)	BSM-180
200-0250-010 (p. 11)	BSM-250
200-0500-010 (p. 12)	BSM-500



Order number:	Designation	incl. alignment bolts:
205-0115-004	RPC-115-SWBA	5152-0016-001 (p. 47)
205-0115-005	RPC-115-KV	5152-0016-001 (p. 47)
205-0140-004	RPC-140	5152-0016-001 (p. 47)
205-0180-004	RPC-180	5152-0020-001 (p. 47)
205-0250-004	RPC-250	5152-0020-001 (p. 47)
205-0500-004	RPC-500	5151-0040-002 (p. 47)

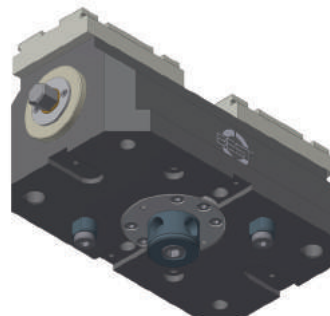
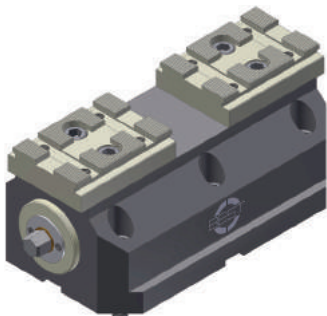

BSMG...



becomes RPCG:

Order number:	Designation
220-0140-004 (p. 15)	BSMG-140
220-0180-005 (p. 16)	BSMG-180
220-0250-004 (p. 17)	BSMG-250



Order number:	Designation	incl. alignment bolts:
225-0140-004	RPCG-140	5152-0016-001 (p. 47)
225-0180-004	RPCG-180	5152-0020-001 (p. 47)
225-0250-004	RPCG-250	5152-0020-001 (p. 47)

You will find the corresponding baseplates for the centric vices on page 42.

You will find the corresponding epoxy mineral tombstones for the centric vices on page 43.

You can find matching 5-axis pyramids and 5-axis pyramid tombstones on page 45.

3.1.2 Baseplates

For zero-point adjustment of the RPC centric vice (see page 41) and the pallets (see below).
Delivery includes clamping screw.

Round version:

Order number:	Diameter mm	Height mm	for alignment bolts:
281-0157-001	157	27	5152-0016-001 (p. 47)
281-0186-001	186	27	5152-0016-001 and 5152-0020-001 (p. 47)

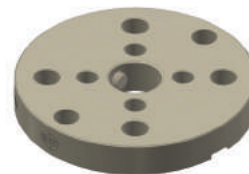

Rectangular version:

Order number:	Length mm	Width mm	Height mm	for alignment bolts:
281-0150-001	150	116	27	5152-0016-001 (p. 47)
281-0196-001	196	156	27	5152-0016-001 and 5152-0020-001 (p. 47)
281-0250-001	250	190	27	5152-0016-001 and 5152-0020-001 (p. 47)
281-0500-001	500	190	27	5151-0040-002 (p. 47)

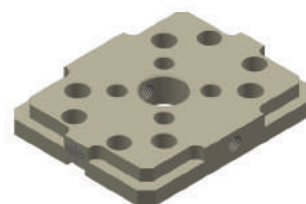

3.1.3 Pallets

For adaptation of clamping elements or fixtures on the baseplate.
Delivery includes a tightening bolt and two alignment bolts.

Round version:

Order number:	Diameter mm	Height mm	incl. alignment bolts:
282-0157-001	157	27	5152-0016-001 (p. 47)
282-0186-001	186	27	5152-0020-001 (p. 47)

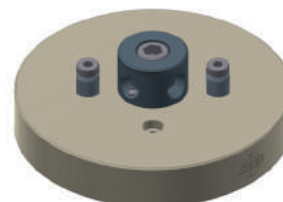

Rectangular version:

Order number:	Length mm	Width mm	Height mm	incl. alignment bolts:
282-0150-001	150	116	27	5152-0016-001 (p. 47)
282-0196-001	196	156	27	5152-0020-001 (p. 47)

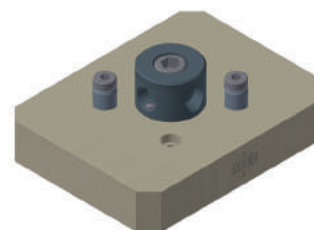

Example for the adaptation of a centric vice without zero-point connection on a baseplate

3.1.4 Epoxy mineral tombstones with integrated Realpoint zero-point clamping system

Features:

- Material: Steel – mineral cast
- Low net weight, stable construction
- Low-vibration: values 10 x better than GG20, 100 x better than high-strength aluminium
- Linear expansion coefficient: here, values 100 % better than aluminium can be achieved
- Heat conductivity: minimal linear expansion under temperature fluctuations
- Thanks to the integrated Realpoint zero-point clamping system, any centric vice from product families RPC and RPCG (see page 41) can be quickly replaced
- Vices from other manufacturers can be quickly replaced on the tombstone with the help of a BEST pallet

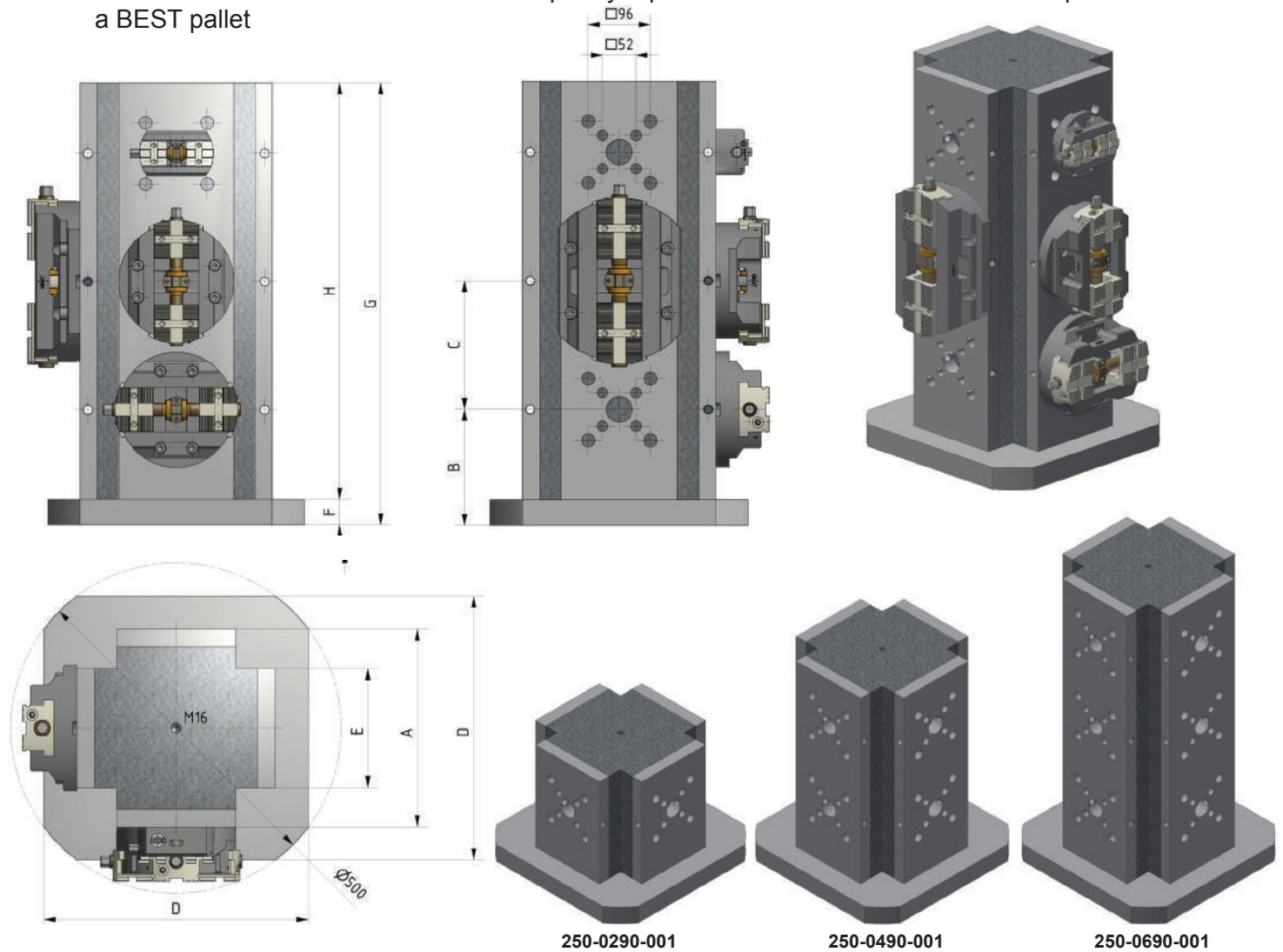

Table of dimensions:

Order number:	Designation	A mm	B mm	C mm	D mm	E mm	F mm	G mm	H mm	Approx. kg
250-0290-001	BMT290 1RP	300	180	-	400	180	40	290	250	76
250-0490-001	BMT490 2RP	300	180	200	400	180	40	490	450	120
250-0690-001	BMT690 3RP	300	180	200	400	180	40	690	650	160

You will find the corresponding centric vices for the tombstones on page 41.

The corresponding pallets for mounting vices from other manufacturers can be found on page 42.

Tombstones in other materials, (e.g. cast or steel), heights and shapes and designed with different hole matrix spacings are available on request.

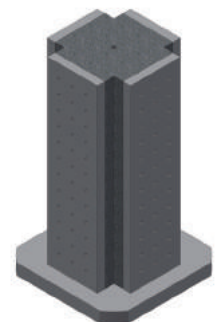

Hole pattern tombstone, special size

3.1.5 5-axis riser

5-axis riser for an ideal degree of freedom during the 5-axis processing when using a vice. The raised position makes the workpiece optimally accessible. We can supply the 5-axis riser in a range of heights and ideally matched to your machine. The standard design is in steel, additional materials are available on request.

Either the BEST Realpoint zero point system or a fixed mounting position is possible as interface to the vice.

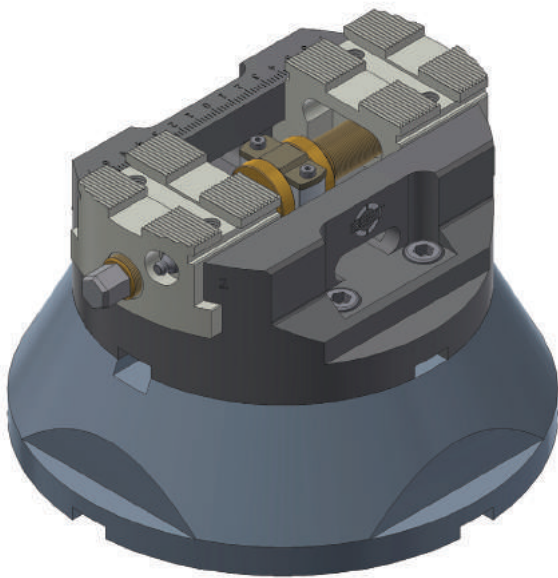

6310-0250-001:
Riser for BSM-180
70 mm high

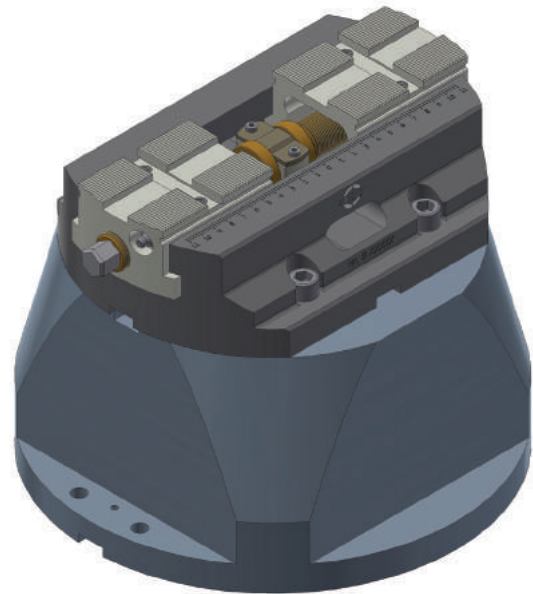

6310-0300-001:
Riser for BSM-250
150 mm high



Application example with BSM-250 and prism jaws
The riser is 200 mm high

3.1.6 5-axis pyramid

5-axis pyramid for an ideal degree of freedom during the 5-axis processing with multiple clamping positions. The slanted arrangement of the vice allows all workpiece to be ideally accessible. We can supply the pyramids in a range of materials, sizes and forms ideally matched to your machine.

Either the BEST Realpoint zero point system or a fixed mounting position is possible as interface to the vice.

Features:

- Material: Steel–mineral cast
- Low net weight, stable construction
- Low-vibration: values 10 x better than GG20, 100 x better than high-strength aluminium
- Linear expansion coefficient: here, values 100 % better than aluminium can be achieved
- Heat conductivity: minimal linear expansion under temperature fluctuations
- Thanks to the integrated Realpoint zero-point clamping system, any centric vice from product families RPC and RPCG (see page 41) can be quickly replaced
- Vices from other manufacturers can be quickly replaced with the help of a BEST pallet on the 5-axis pyramid

Design examples (we will be happy to adapt the pyramid to your machine):

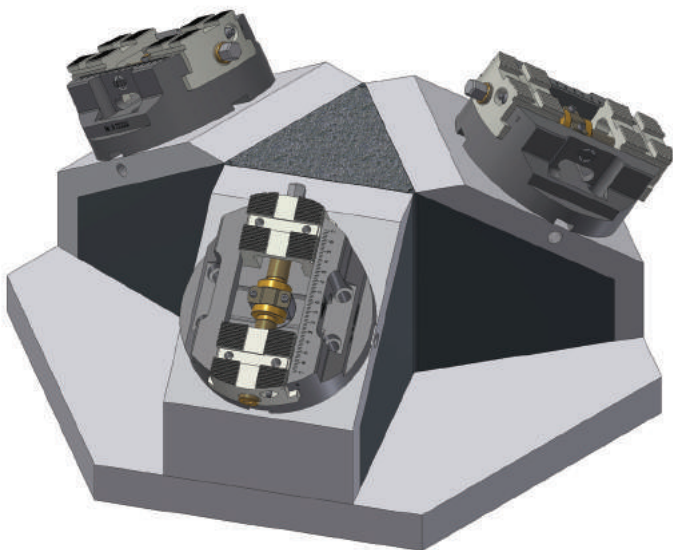

5-axis pyramid with 3 clamping positions

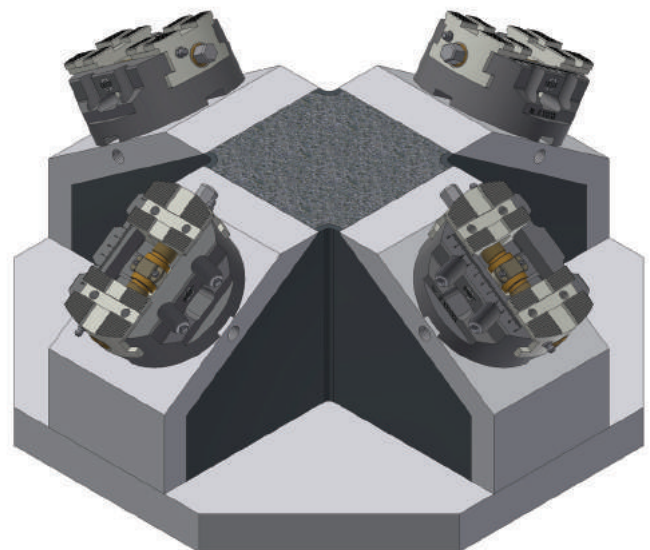

5-axis pyramid with 4 clamping positions

You will find the corresponding centric vices for the tombstones on page 41.

The corresponding pallets for mounting vices from other manufacturers can be found on page 42.

3.1.7 5-axis pyramid tombstone

5-axis pyramid tombstone for an ideal degree of freedom during the 5-axis processing with maximum number of clamping positions. Through the arrangement in different angles of tombstone and pyramid, all workpieces are optimally accessible. We can supply the pyramid tombstone in a range of materials, sizes and forms ideally matched to your machine.

Either the BEST Realpoint zero point system or a fixed mounting position is possible as interface to the vice.

Features:

- Material: Steel–mineral cast
- Low net weight, stable construction
- Low-vibration: values 10 x better than GG20, 100 x better than high-strength aluminium
- Linear expansion coefficient: here, values 100 % better than aluminium can be achieved
- Heat conductivity: minimal linear expansion under temperature fluctuations
- Thanks to the integrated Realpoint zero-point clamping system, any centric vice from product families RPC and RPCG (see page 41) can be quickly replaced
- Vices from other manufacturers can be quickly replaced with the help of a BEST pallet on the 5-axis pyramid tombstone

Design examples (we will be happy to adapt the 5-axis pyramid tombstone to your machine):

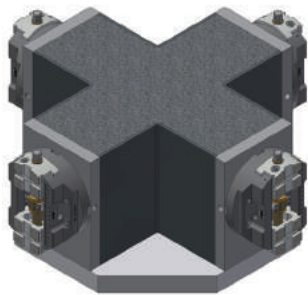

Bottom part to 5-axis pyramid tombstone (4 clamping positions)

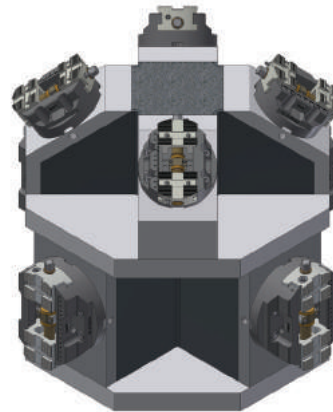

5-axis pyramid tombstone with 8 clamping positions

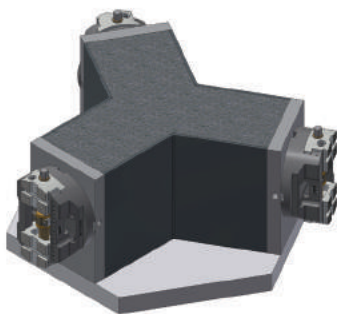

Bottom part to 5-axis pyramid tombstone (3 clamping positions)

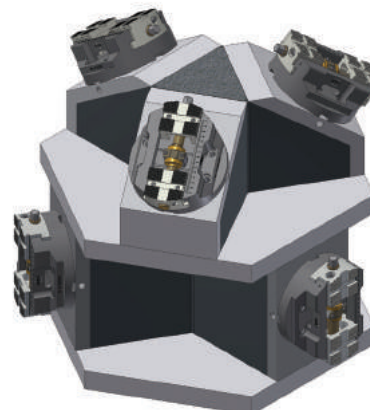

5-axis pyramid tombstone with 6 clamping positions

You will find the corresponding centric vices for the tombstones on page 41.

The corresponding pallets for mounting vices from other manufacturers can be found on page 42.

3.1.8 Accessories

Order number:	Designation
5151-0040-001	Realpoint tightening bolt
The tightening bolt fits all centric vice and pallet models (see pages 41 and 42) Diameter: 40 mm	



Order number:	Designation
5151-0040-002	Realpoint tightening bolt, sword-shaped
For aligning centric vice RPC-500 (see page 41) Diameter: 40 mm	

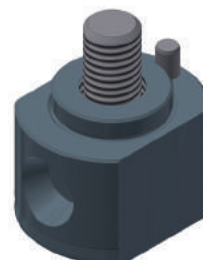

Order number:	Designation
5701-0016-001	Realpoint clamping screw
The clamping screw for drawing in the tightening bolts 5151-0040-001 (included in the scope of delivery for the baseplates on page 42)	

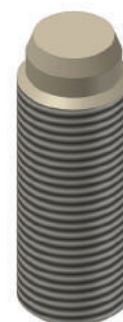

Order number:	Designation
5152-0016-001	Realpoint alignment bolt
For the alignment of centric vices (see page 41) and pallets (see page 42) Diameter: 16 mm	



Order number:	Designation
5152-0020-001	Realpoint alignment bolt
For the alignment of centric vices (see page 41) and pallets (see page 42) Diameter: 20 mm	



Order number:	Designation
6904-0020-022	Flat slot nut incl. screw M6x12
Dimensions: 20 x 10 x 22 mm (LxWxH)	

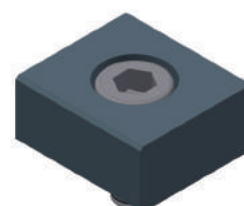



Order number:	Designation
6901-0060-001	Torque wrench
For controlled clockwise tightening with lever ratchet wrench 40–200 Nm torque Length: 456 mm Square: 1/2 inch Feel free to contact us if you require a torque wrench featuring a different design.	



Order number:	Designation
6902-0013-001	Socket wrench WAF 13
6902-0015-001	Socket wrench WAF 15
6902-0017-001	Socket wrench WAF 17
6902-0024-001	Socket wrench WAF 24

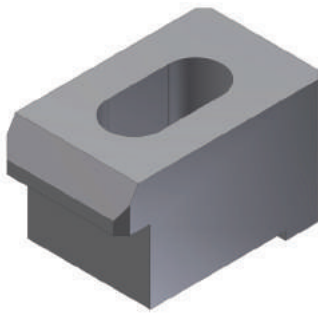

Order number:	Designation
6905-0050-001	Clamping claw M12
For attaching the centric vices to your machining table Clamping height: 20 mm Dimensions: 50 x 40 x 27 mm (LxWxH) Feel free to contact us if you require a different clamping claw.	



Order number:	Designation
6904-0410-002	BEST special grease
Special lubricating grease to ensure optimum clamping for the centric vices. 500 g cartridge for hand-lever press (6904-0500-001 see below).	



Order number:	Designation
6904-0500-001	Grease gun
High-pressure hand-lever grease gun for lubricating the vice with grease. Filling with grease cartridge 6904-0410-002 (see above).	

3.2 Adaptation to zero-point systems of other manufacturers

The mechanical centric vices from BEST can be adapted to your existing zero-point systems of other manufacturers. The following provides a brief overview of already implemented solutions, adaptations to systems of additional manufacturers are possible upon request.

Erowa

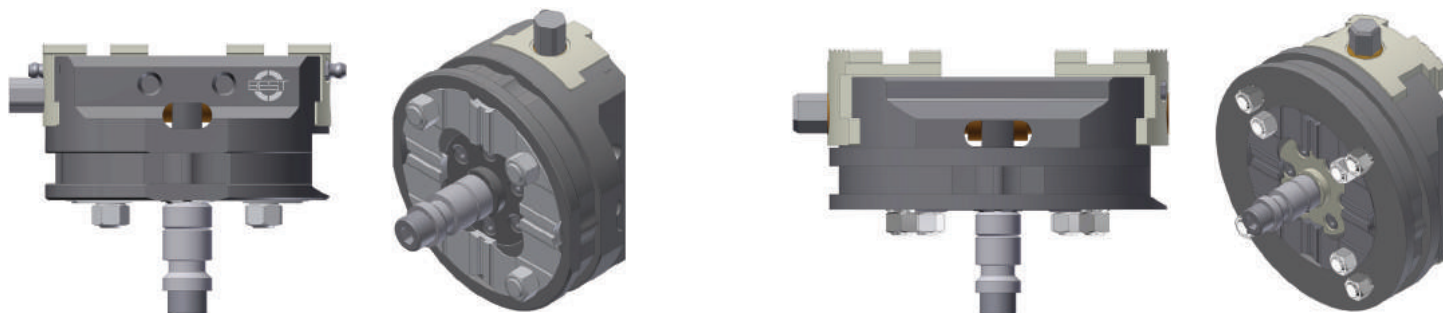

Order number:	200-0115-016	200-0140-011
Designation:	BSM-115 EROWA	BSM-140 EROWA
<p>These centric vices feature a G Inox centring plate with connection Erowa ITS 115 (200-0115-016) and Erowa ITS 148 (200-0140-011) directly integrated. This centric vice is thus ideally suited for direct use in corresponding Erowa clamping heads. The big advantages here are the extremely flat design and high clamping forces, analogue to centric vice BSM-115 (see page 8) and BSM-140 (see page 9).</p>		

LANG

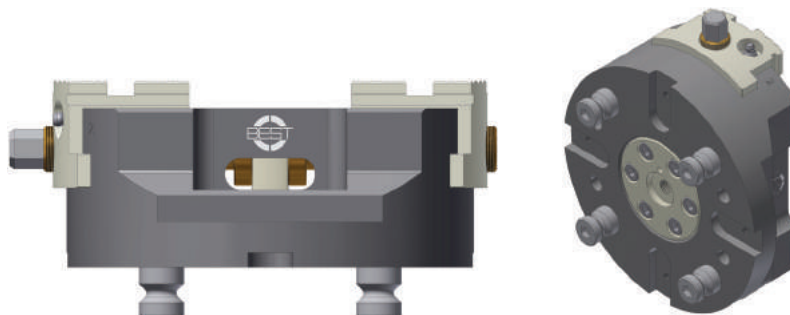

Order number:	200-0180-010
Designation:	BSM-180 (Standard model, see Page 8, LANG bolts not included in the scope of delivery)
<p>You can easily adapt the vices of the lines BSM and BSMG by attaching the LANG zero-point bolts on the underside of the BEST vices on their existing LANG zero-point plates.</p>	

Schunk

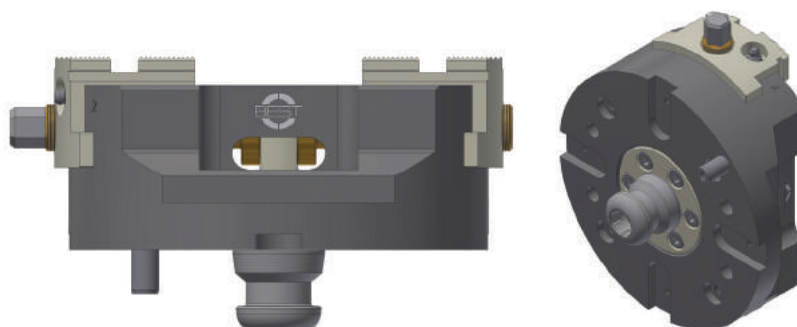

Order number:	200-0180-010-01
Designation:	BSM-180 Schunk
<p>Retrofitting of the bolt interface for the Schunk Vero-S zero point system in the desired inside calliper is possible depending on the vice model. Please let us know your requirements.</p>	

Hoffmann

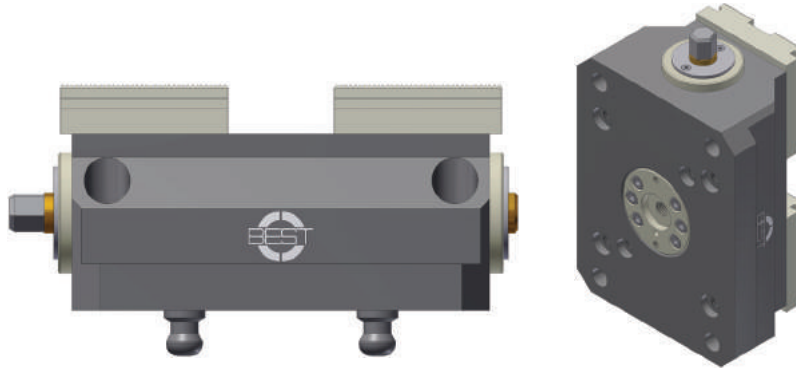

Order number:	920-0180-002
Designation:	BSMG-180 Zero Clamp
Retrofitting of the bolt interface for the Zero Clamp zero point system in the desired inside calliper is possible depending on the vice model. Please let us know your requirements.	

Vischer & Bolli

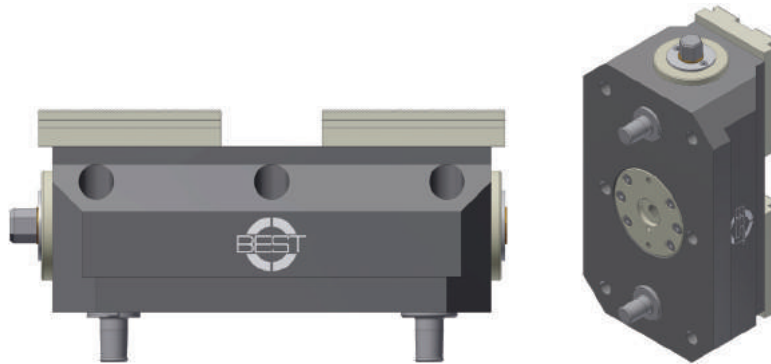

Order number:	920-0250-001
Designation:	BSMG-250 VB
Retrofitting of the bolt interface for the Vischer & Bolli Dock Lock zero point system in the desired inside calliper is possible depending on the vice model. Please let us know your requirements.	

PAROTEC

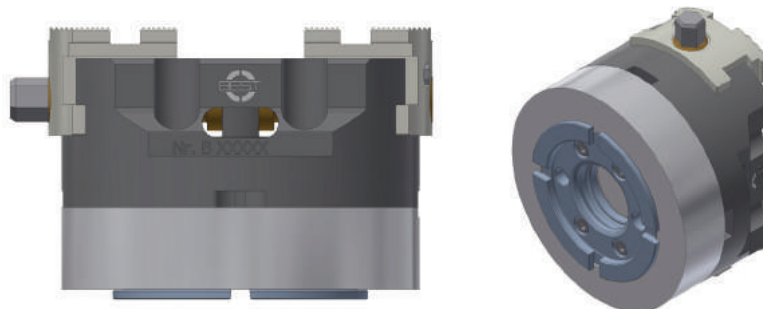

Order number:	200-0140-015
Designation:	BSM-140 Parotec
The Power-Grip zero point system from PAROTEC can be integrated with a carrier plate. Please let us know which vice size you require.	

Adaptation to zero point system of additional manufacturers available on request.

4. Adaptation to rotary tables

A spacer plate can be used to fasten the mechanical centric vices from BEST to fit exactly on the NC rotary tables of various manufacturers (e.g. HAAS, Kitagawa, Lehmann, Nikken).

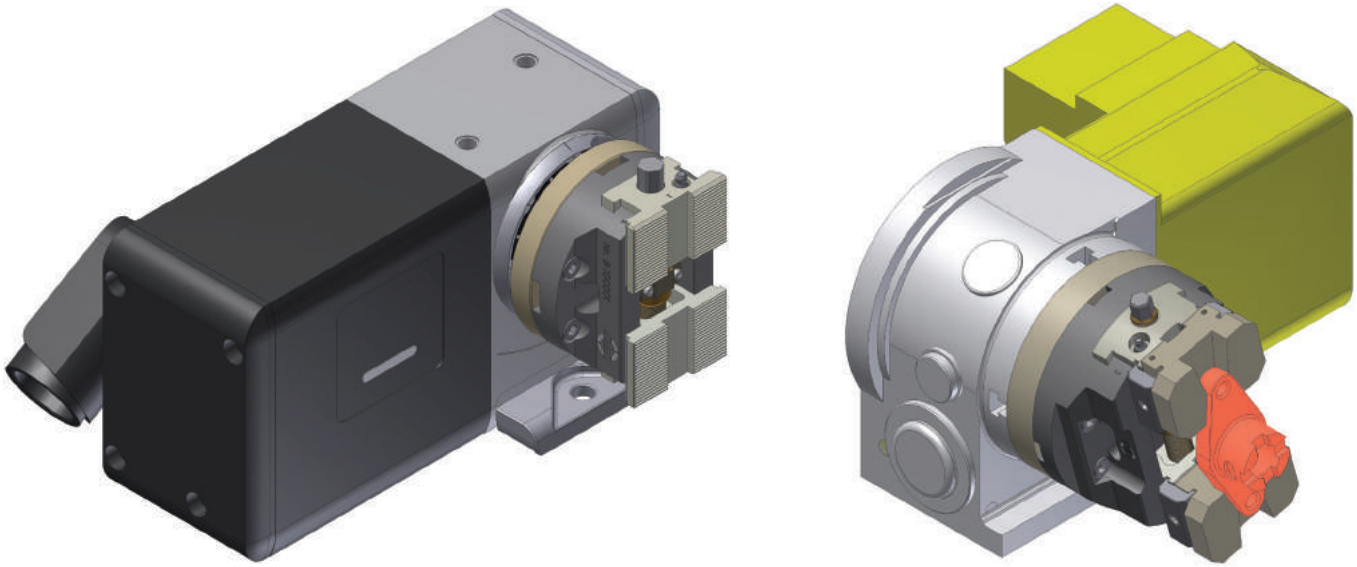

Advantages through rotary tables in combination with BEST vices:

- Expansion from 3- or 4-axle machine by one additional axle
- Compact system through BEST vice BSM
- Round design of the BSM vice, ideal for rotary table

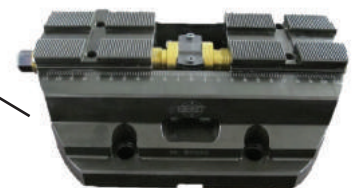
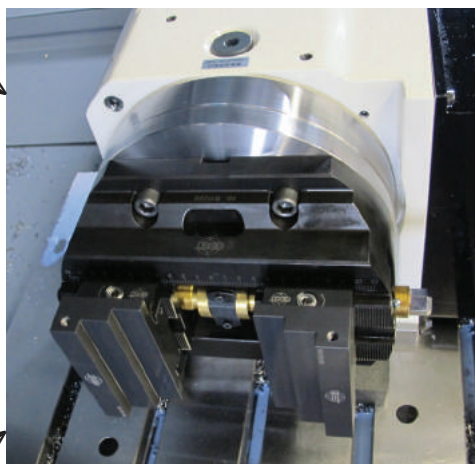
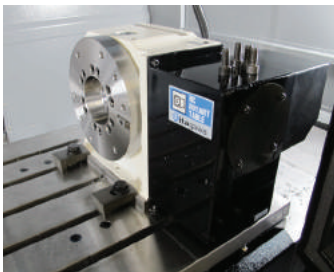

Simply send us the technical specifications of your rotary table and we will gladly send you an offer for a matching adapter plate, including vice and jaws for your production.

5. Vices for automation solutions

5.1. Pneumatic vice models

5.1.1. Pneumatic centric vices

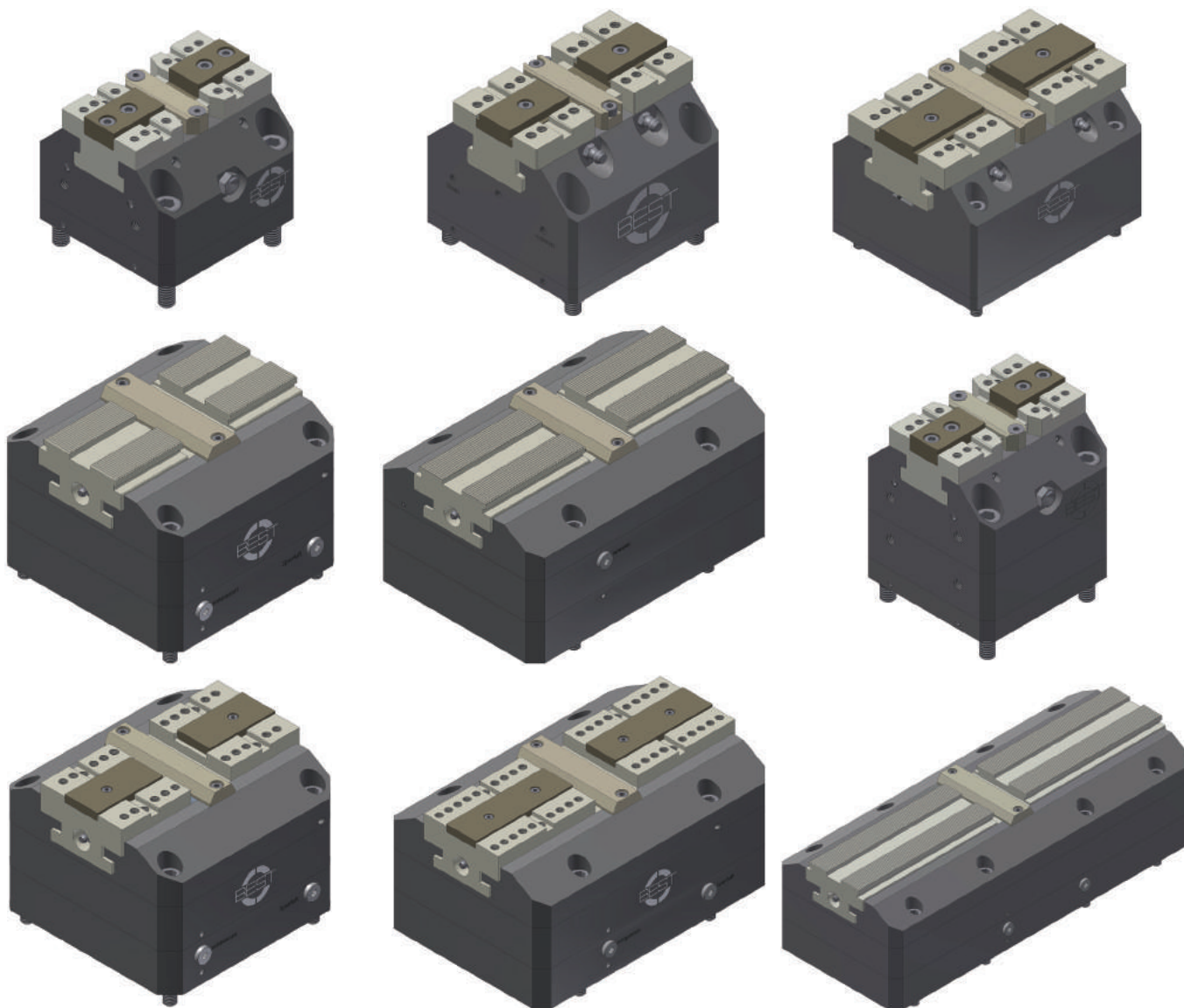

Advantages of the BEST pneumatic vices:

- Extremely high rigidity as a result of solid design
- Extremely high clamping forces (up to 40 kN)
- Housing sizes from 64 mm to 250 mm (in the standard design, larger models are available on request)
- Repetition accuracy of 0.005 mm (with ground-in jaws)
- Centring accuracy of +/- 0.01 mm (with ground in jaws)
- Jaw widths of up to 240 mm
- Low wear due to nitrogen-hardened surfaces
- Suitable for internal or external clamping
- Individual special solutions / customer-specific customisations available on request (Please provide us with the specific data for your application, and we will send you a technical draft together with an offer for the number of items you require)
- Compensating clamping

5.1.1.1 Pneumatic centric vices BSP-64

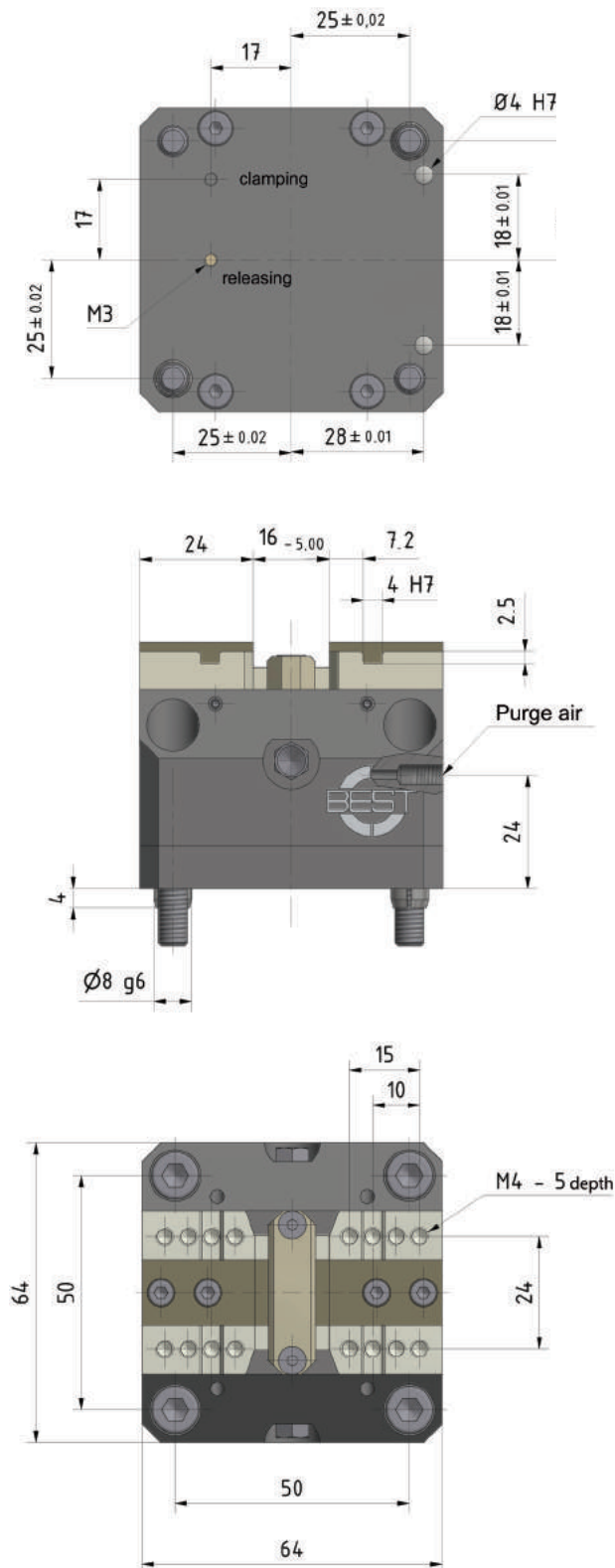

Optional additional functions:

- Compensation function
- Clamping path monitoring
- Central lubrication connection
- Fixed jaw
- Sealing air connection

See optional additional functions, page 77.

Please let us know, if you require one of the additional functions, so that we can take this into consideration in the offer.

Technical data:

Order number:	150-0064-001
Designation:	BSP-64
Dimensions (LxWxH):	64 x 64 x 50 mm
Weight:	1.2 kg
Clamping range:	0–55 mm
Stroke per jaw:	2.5 mm
Max. actuating pressure:	9 bar
Min. actuating pressure:	1 bar
Max. clamping force:	4 kN at 9 bar
Air consumption (6 bar):	186 cm ³ per double stroke
Jaw connection:	Tongue and groove
Air connections:	On the side and underside

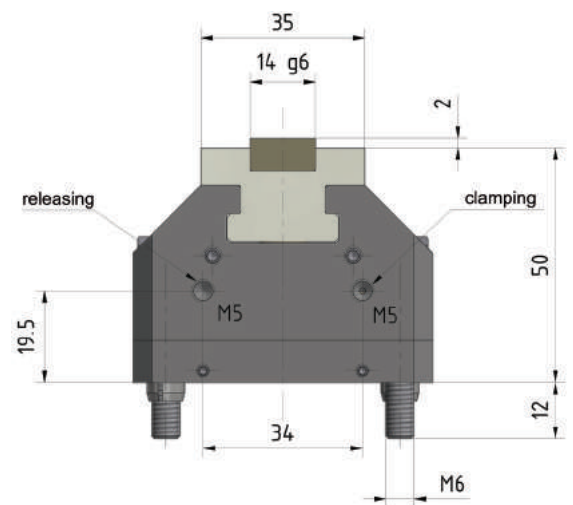
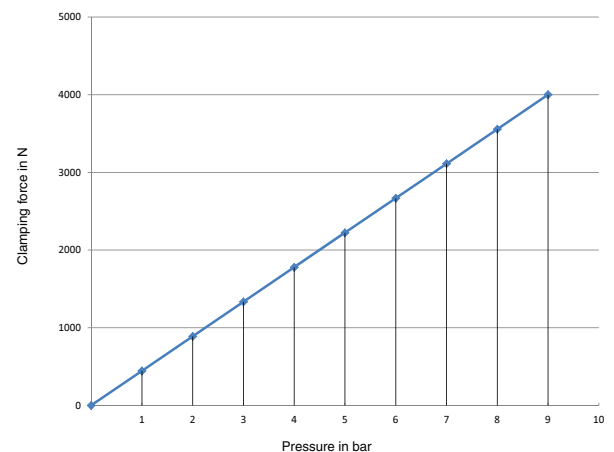

Chart clamping force BSP-64



Matching blank jaw:

Order number:	301-0034-001
Dimensions (WxLxH):	36 x 29 x 18 mm
Material:	16 MnCr5

Seal set (for maintenance):

Order number:	100,350,064
---------------	-------------

5.1.1.2 Pneumatic centric vices BSP-100

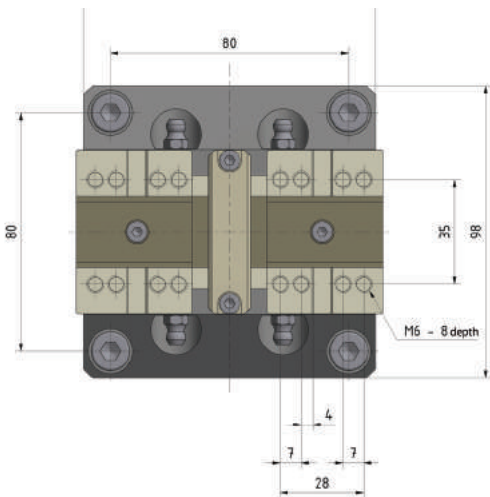
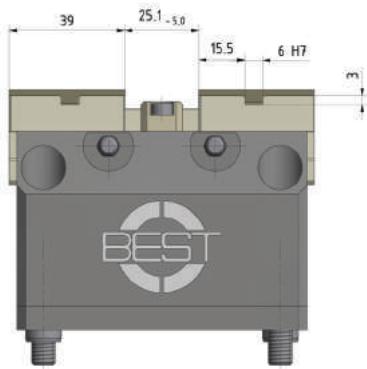
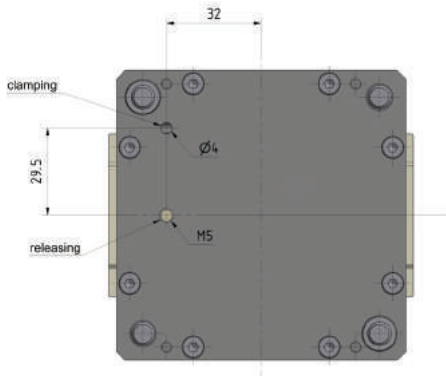

Technical data:

Order number:	150-0100-005
Designation:	BSP-100
Dimensions (LxWxH):	98 x 98 x 79 mm
Weight:	4 kg
Clamping range:	0–90 mm
Stroke per jaw:	2.5 mm
Max. actuating pressure:	9 bar
Min. actuating pressure:	1 bar
Max. clamping force:	14 kN at 9 bar
Air consumption (6 bar):	701 cm ³ per double stroke
Jaw connection:	Tongue and groove
Air connections:	On the side and underside

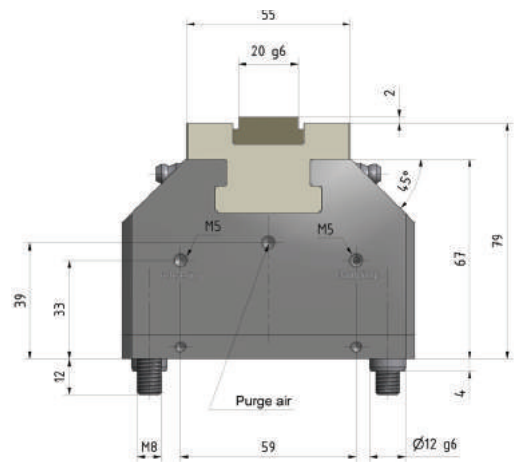
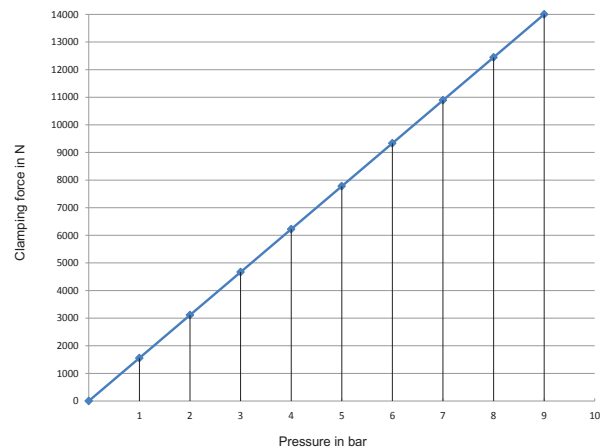

Chart clamping force BSP-100



Optional additional functions:

- Compensation function
- Clamping path monitoring
- Central lubrication connection
- Fixed jaw
- Sealing air connection

See optional additional functions, page 77.
Please let us know, if you require one of the additional functions, so that we can take this into consideration in the offer.

Matching blank jaw:

Order number:	301-0060-002
Dimensions (WxLxH):	60 x 45 x 30 mm
Material:	16 MnCr5

Seal set (for maintenance):

Order number:	100,350,100
---------------	-------------



5.1.1.3 Pneumatic centric vices BSP-160

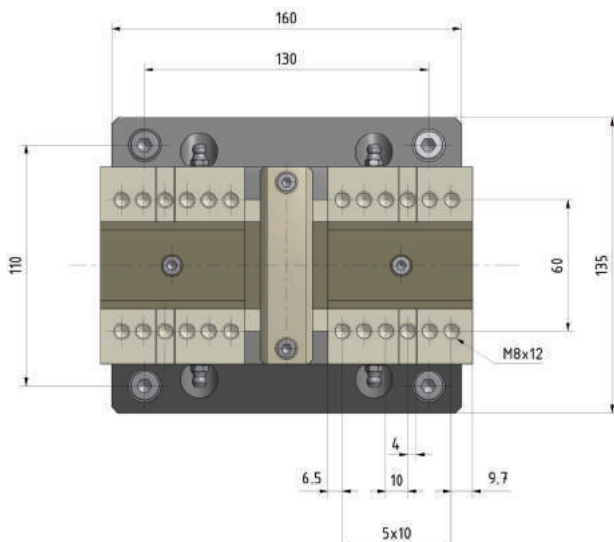
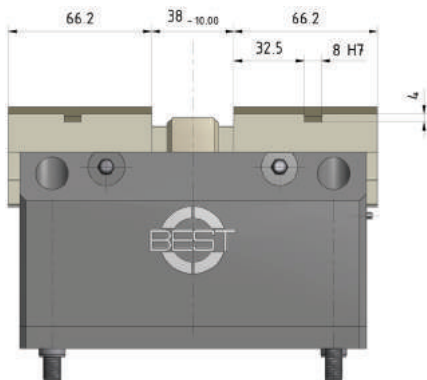
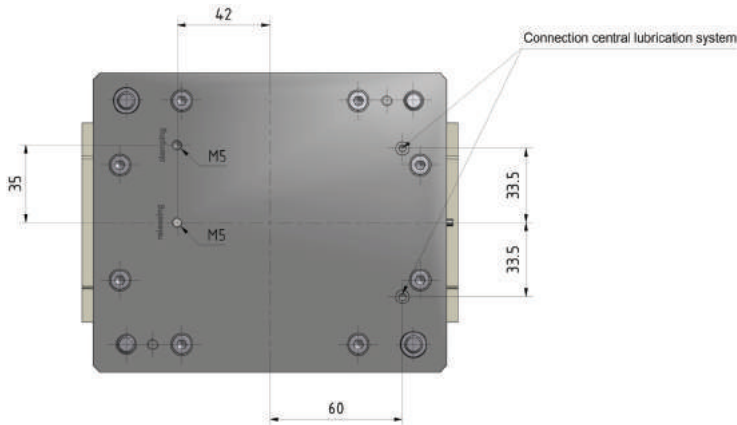

Technical data:

Order number:	150-0160-009
Designation:	BSP-160
Dimensions (LxWxH):	160 x 135 x 108 mm
Weight:	14 kg
Clamping range:	0 – 150 mm
Stroke per jaw:	5 mm
Max. actuating pressure:	9 bar
Min. actuating pressure:	1 bar
Max. clamping force:	25 kN at 9 bar
Air consumption (6 bar):	2490 cm ³ per double stroke
Jaw connection:	Tongue and groove
Air connections:	On the side and underside

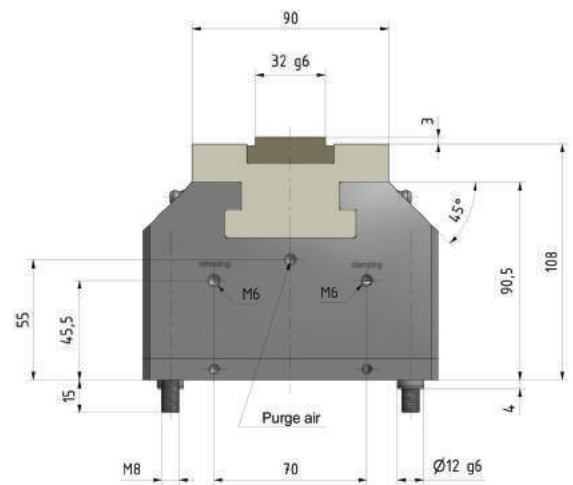
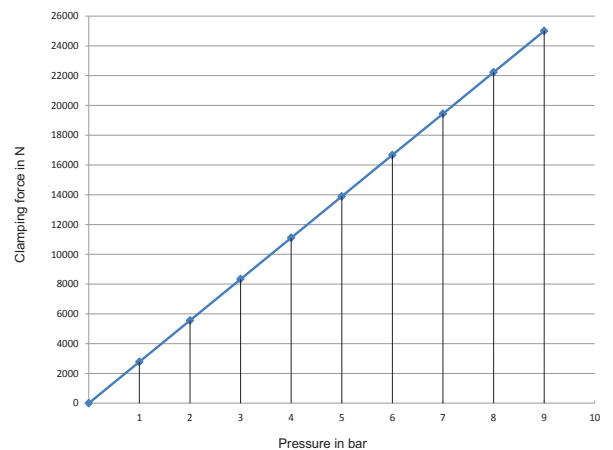

Chart clamping force BSP-160



Optional additional functions:

- Compensation function
- Clamping path monitoring
- Central lubrication connection
- Fixed jaw
- Sealing air connection

See optional additional functions, page 77.
Please let us know, if you require one of the additional functions, so that we can take this into consideration in the offer.

Matching blank jaw:

Order number:	301-0094-008
Dimensions (WxLxH):	94 x 67 x 50 mm
Material:	16 MnCr5

Seal set (for maintenance):

Order number:	100,350,160
---------------	-------------

5.1.1.4 Pneumatic centric vice BSPD-170-SWBA (with double piston)

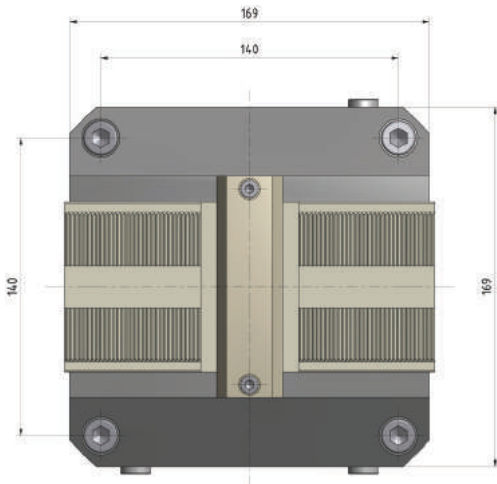
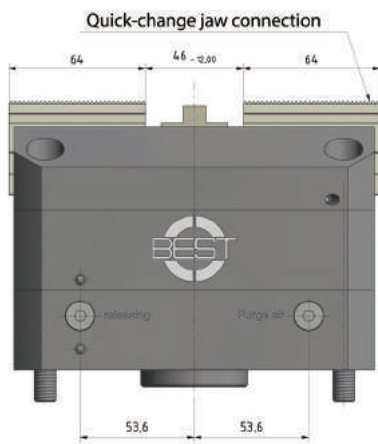
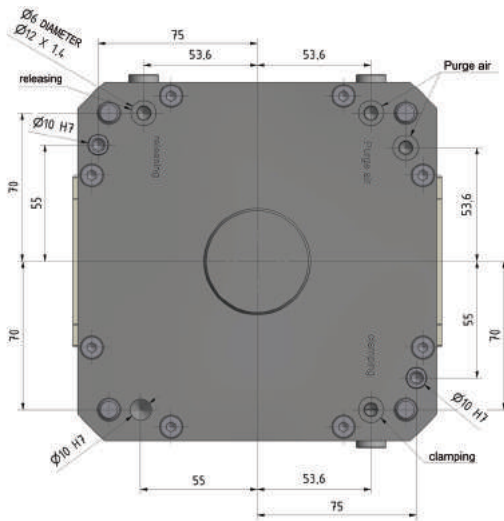

Technical data:

Order number:	152-0170-002
Designation:	BSPD-170-SWBA
Dimensions (LxWxH):	169 x 169 x 126 mm
Weight:	22 kg
Clamping range:	0–160 mm
Stroke per jaw:	6 mm
Max. actuating pressure:	9 bar
Min. actuating pressure:	1 bar
Max. clamping force:	45 kN at 9 bar
Air consumption (6 bar):	4557 cm ³ per double stroke
Jaw connection:	Quick-change
Air connections:	On the side and underside

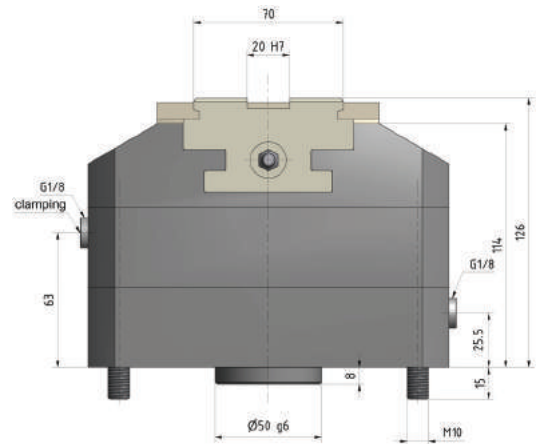
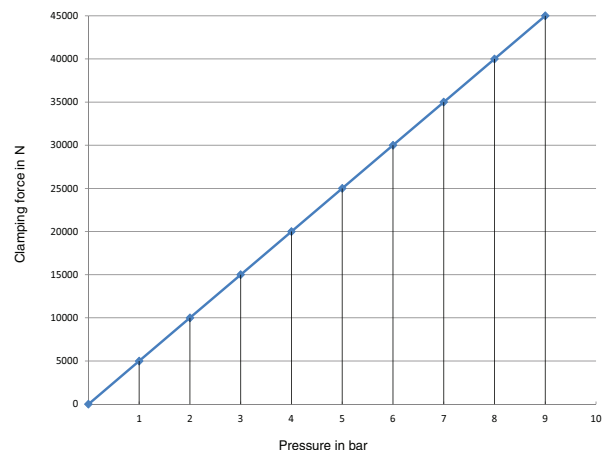

Chart clamping force BSPD-170



Optional additional functions:

- Clamping path monitoring
- Fixed jaw
- Sealing air connection

See optional additional functions, page 77.
Please let us know, if you require one of the additional functions, so that we can take this into consideration in the offer.

Matching jaws:

Pages 30 to 32

Seal set (for maintenance):

Order number:	100,352,170
---------------	-------------

5.1.1.5 Pneumatic centric vice BSPD-170-KV (with double piston)

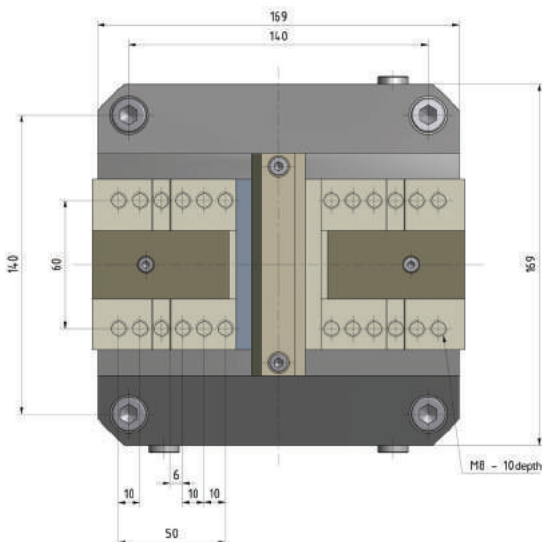
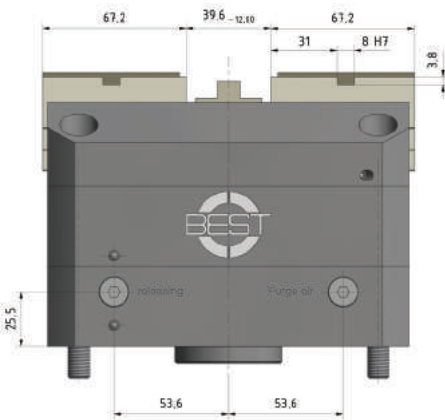
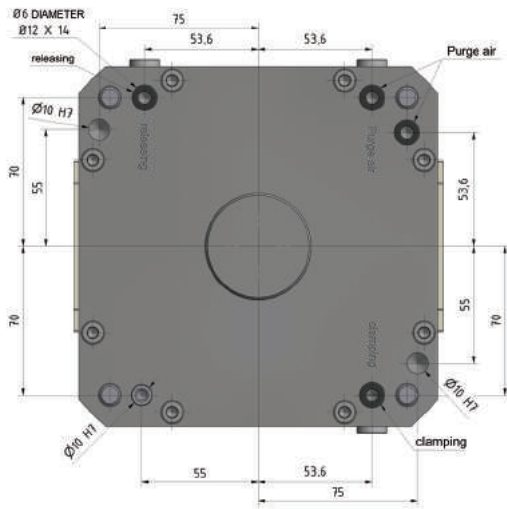

Technical data:

Order number:	152-0170-003
Designation:	BSPD-170-KV
Dimensions (LxWxH):	169 x 169 x 126 mm
Weight:	22 kg
Clamping range:	0 – 160 mm
Stroke per jaw:	6 mm
Max. actuating pressure:	9 bar
Min. actuating pressure:	1 bar
Max. clamping force:	45 kN at 9 bar
Air consumption (6 bar):	4557 cm ³ per double stroke
Jaw connection:	Tongue and groove
Air connections:	On the side and underside

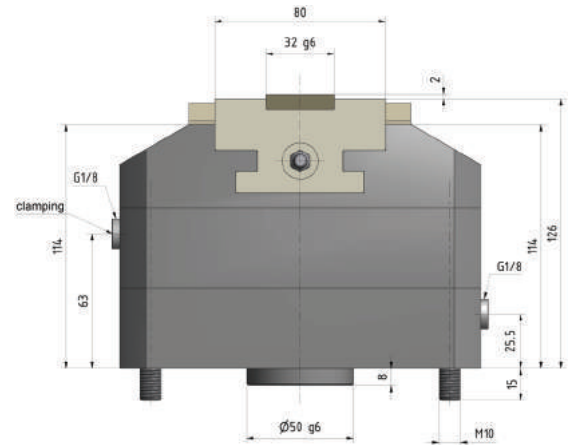
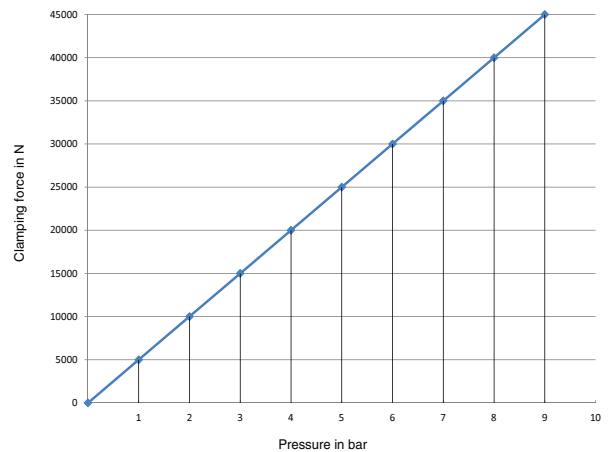

Chart clamping force BSPD-170



Optional additional functions:

- Clamping path monitoring
- Fixed jaw
- Sealing air connection

See optional additional functions, page 77.
Please let us know, if you require one of the additional functions, so that we can take this into consideration in the offer.

Matching blank jaw:

Order number:	301-0094-008
Dimensions (WxLxH):	94 x 67 x 50 mm
Material:	16 MnCr5

Seal set (for maintenance):

Order number:	100,352,170
---------------	-------------

5.1.1.6 Pneumatic centric vice BSPD-250-SWBA (with double piston)

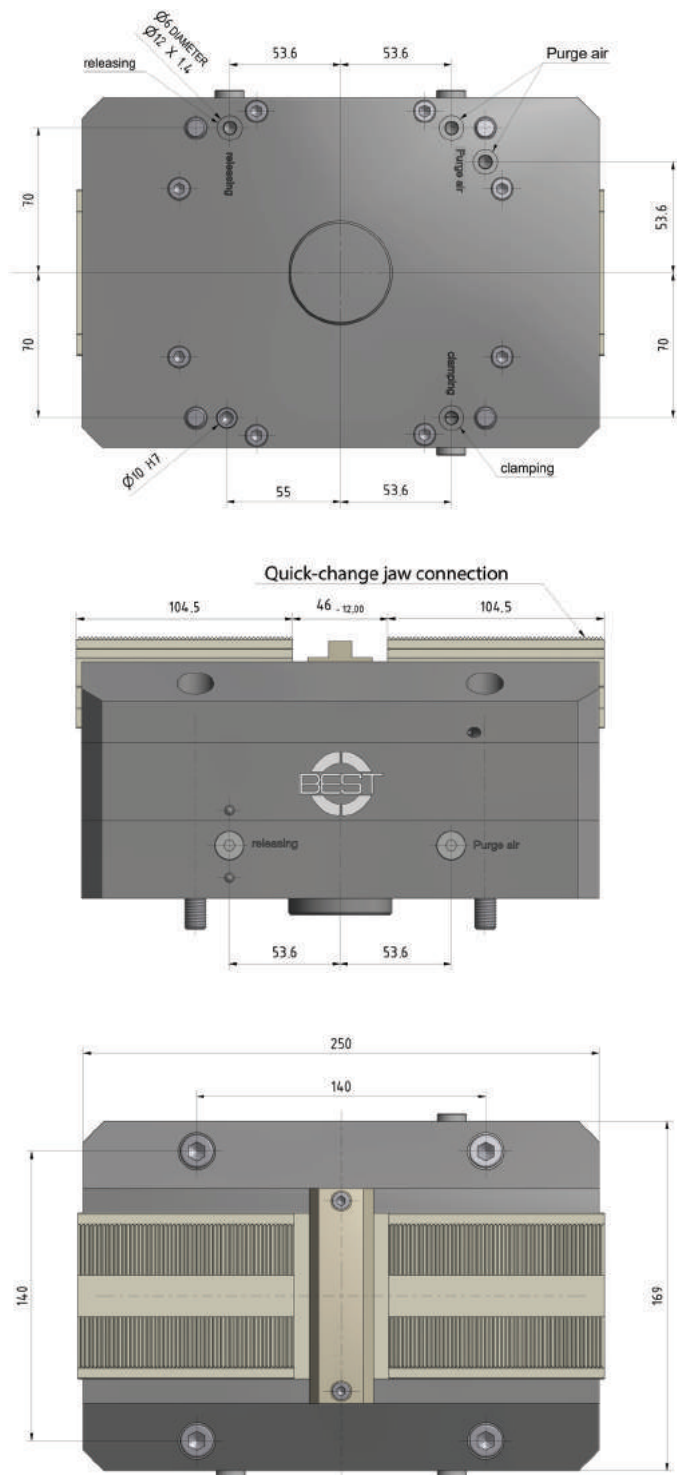

Technical data:

Order number:	152-0250-002
Designation:	BSPD-250-SWBA
Dimensions (LxWxH):	250 x 169 x 126 mm
Weight:	35 kg
Clamping range:	0–240 mm
Stroke per jaw:	6 mm
Max. actuating pressure:	9 bar
Min. actuating pressure:	1 bar
Max. clamping force:	45 kN at 9 bar
Air consumption (6 bar):	4557 cm ³ per double stroke
Jaw connection:	Quick-change
Air connections:	On the side and underside

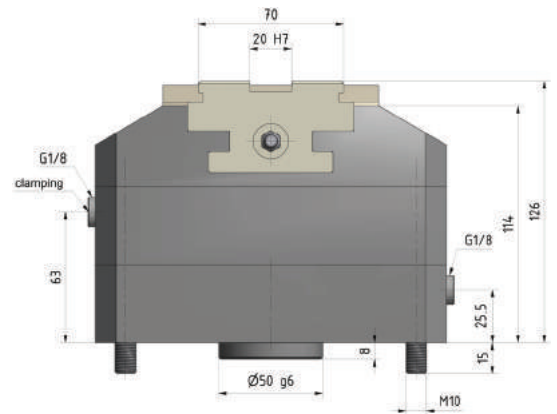
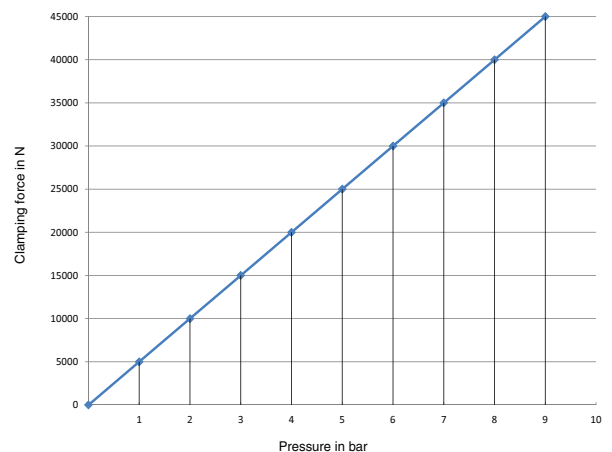

Chart clamping force BSPD-250



Optional additional functions:

- Clamping path monitoring
- Fixed jaw
- Sealing air connection

See optional additional functions, page 77.

Please let us know, if you require one of the additional functions, so that we can take this into consideration in the offer.

Matching jaws:

Pages 30 to 32

Seal set (for maintenance):

Order number:	100,352,170
---------------	-------------

5.1.1.7 Pneumatic centric vice BSPD-250-KV (with double piston)

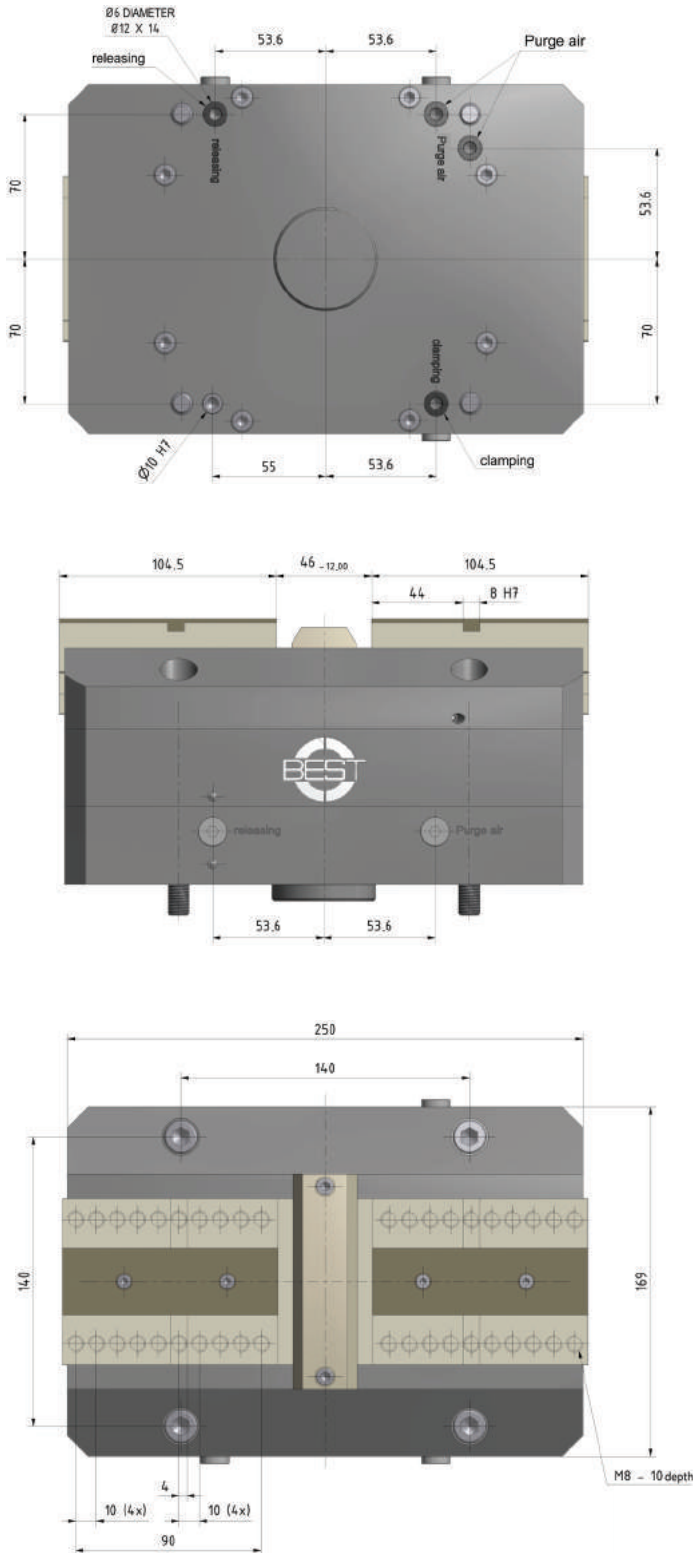

Technical data:

Order number:	152-0250-003
Designation:	BSPD-250-KV
Dimensions (LxWxH):	250 x 169 x 126 mm
Weight:	35 kg
Clamping range:	0–240 mm
Stroke per jaw:	6 mm
Max. actuating pressure:	9 bar
Min. actuating pressure:	1 bar
Max. clamping force:	45 kN at 9 bar
Air consumption (6 bar):	4557 cm ³ per double stroke
Jaw connection:	Tongue and groove
Air connections:	On the side and underside

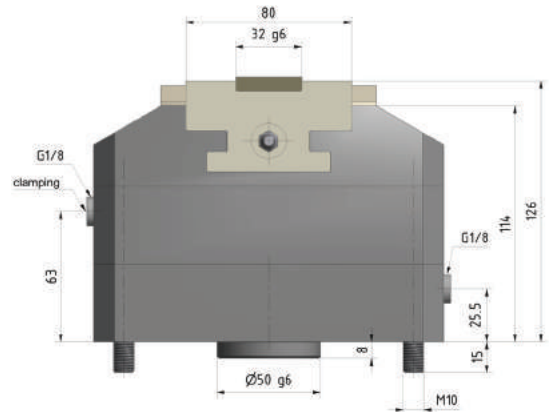
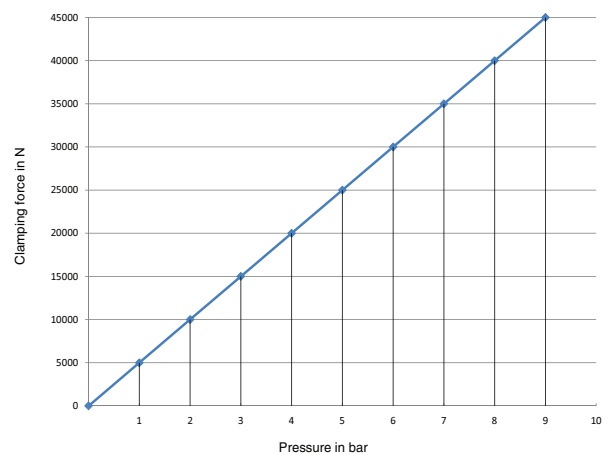

Chart clamping force BSPD-250



Optional additional functions:

- Clamping path monitoring
- Fixed jaw
- Sealing air connection

See optional additional functions, page 77.
Please let us know, if you require one of the additional functions, so that we can take this into consideration in the offer.

Matching blank jaw:

Order number:	301-0150-006
Dimensions (WxLxH):	150 x 120 x 70 mm
Material:	16 MnCr5

Seal set (for maintenance):

Order number:	100,352,170
---------------	-------------

5.1.1.8 Pneumatic centric vice special size BSPD-64-KV (with double piston)

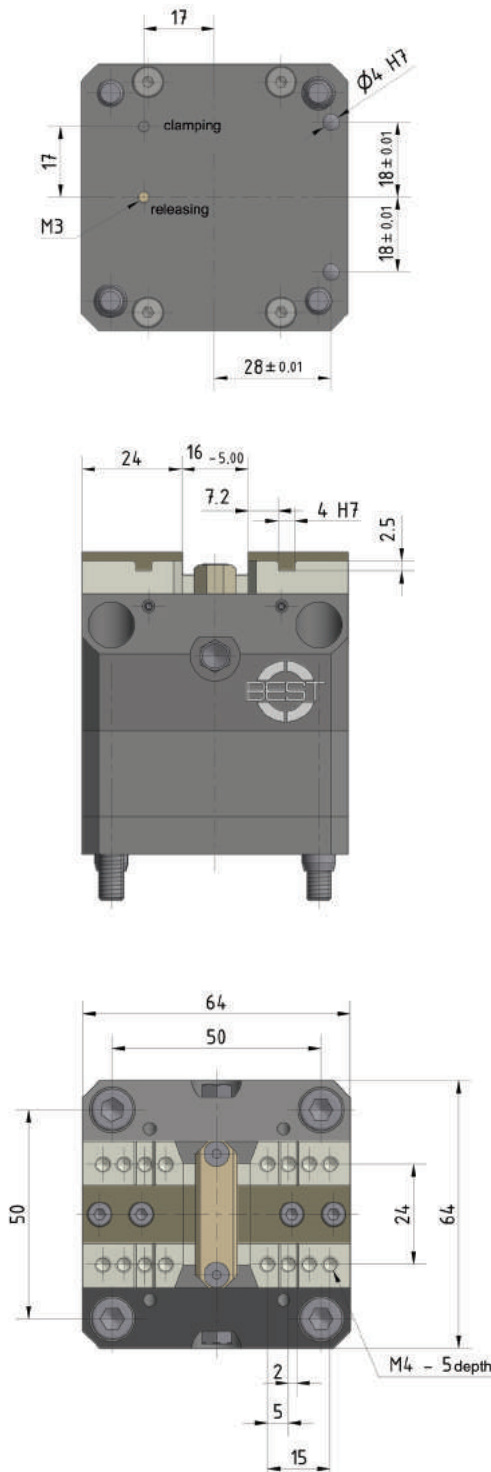

Technical data:

Order number:	152-0064-001
Designation:	BSPD-64-KV
Dimensions (LxWxH):	64 x 64 x 70.8 mm
Weight:	1.8 kg
Clamping range:	0–55 mm
Stroke per jaw:	2.5 mm
Max. actuating pressure:	9 bar
Min. actuating pressure:	1 bar
Max. clamping force:	8 kN at 9 bar
Air consumption (6 bar):	372 cm ³ per double stroke
Jaw connection:	Tongue and groove
Air connections:	On the side and underside

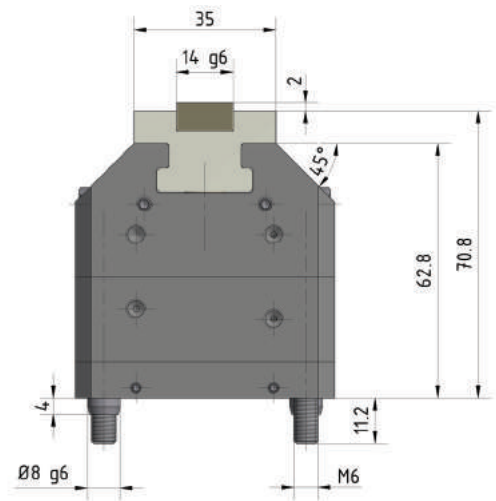
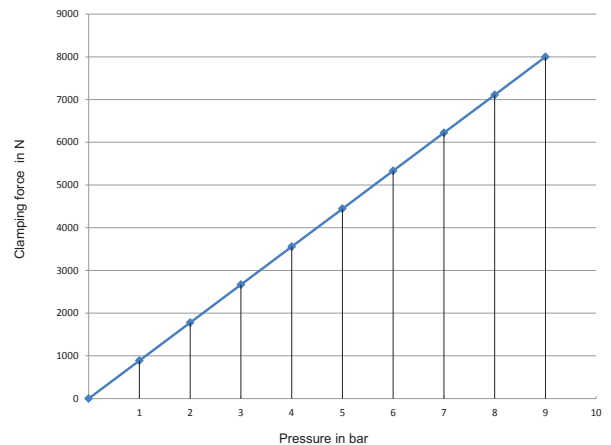

Chart clamping force BSPD-64



Optional additional functions:

- Fixed jaw
- Sealing air connection
- Clamping path monitoring

See optional additional functions, page 77.
Please let us know, if you require one of the additional functions, so that we can take this into consideration in the offer.

Matching blank jaw:

Order number:	301-0034-001
Dimensions (WxLxH):	36 x 29 x 18 mm
Material:	16 MnCr5

Seal set (for maintenance):

Order number:	100,352,064
---------------	-------------

5.1.1.9 Pneumatic centric vice special size BSPD-420-SWBA (with double piston)

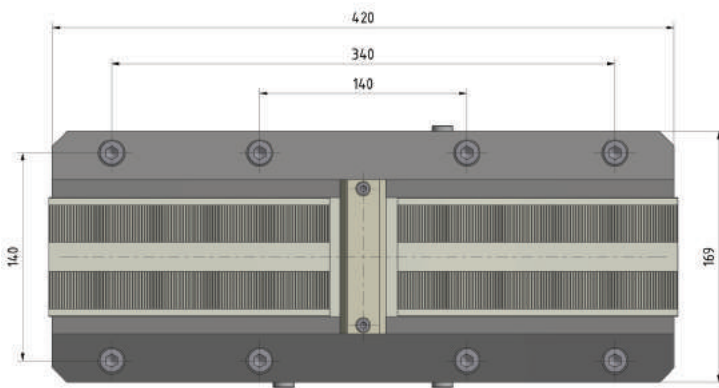
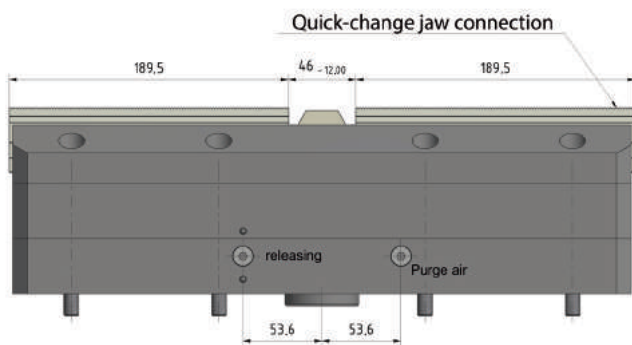
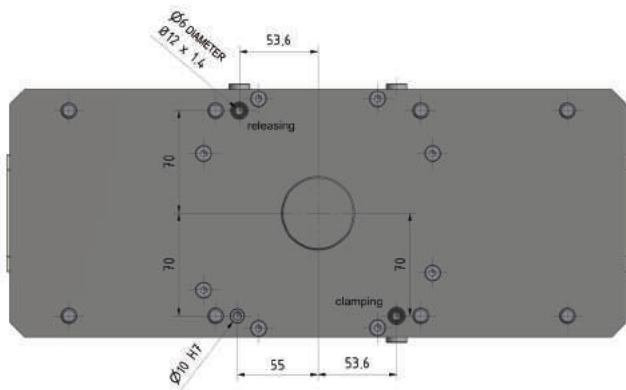

Technical data:

Order number:	152-0420-001
Designation:	BSPD-420-SWBA
Dimensions (LxWxH):	420 x 169 x 129 mm
Weight:	60 kg
Clamping range:	0–410 mm
Stroke per jaw:	6 mm
Max. actuating pressure:	9 bar
Min. actuating pressure:	1 bar
Max. clamping force:	45 kN at 9 bar
Air consumption (6 bar):	4557 cm ³ per double stroke
Jaw connection:	Quick-change
Air connections:	On the side and underside

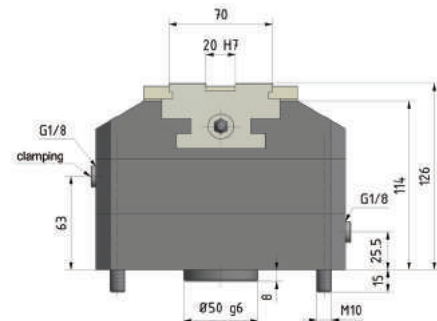
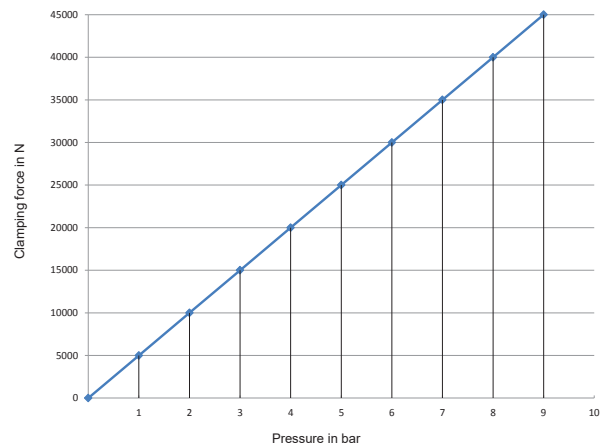

Chart clamping force BSPD-420



Optional additional functions:

- Fixed jaw
- Sealing air connection
- Clamping path monitoring

See optional additional functions, page 77.
Please let us know, if you require one of the additional functions, so that we can take this into consideration in the offer.

Matching jaws:

Pages 30 to 32

Seal set (for maintenance):

Order number:	100,352,170
---------------	-------------

5.1.1.10 Pneumatic centric vice with maintenance of pressure

Principle of function:

- Pneumatic centric vice (in this example here, vice BSP-100, see Page 54) on a pallet with pressure maintenance valve
- The workpiece can be prepared externally
- Clamping and releasing occurs by means of a blowing-out pistol
- The pallet can be mounted to a Realpoint baseplate (see page 42) onto the machine (no alignment to the machine is thus necessary)
- **No compressed air is necessary during the processing**
- Clamping pressure is maintained through pressure maintenance valve

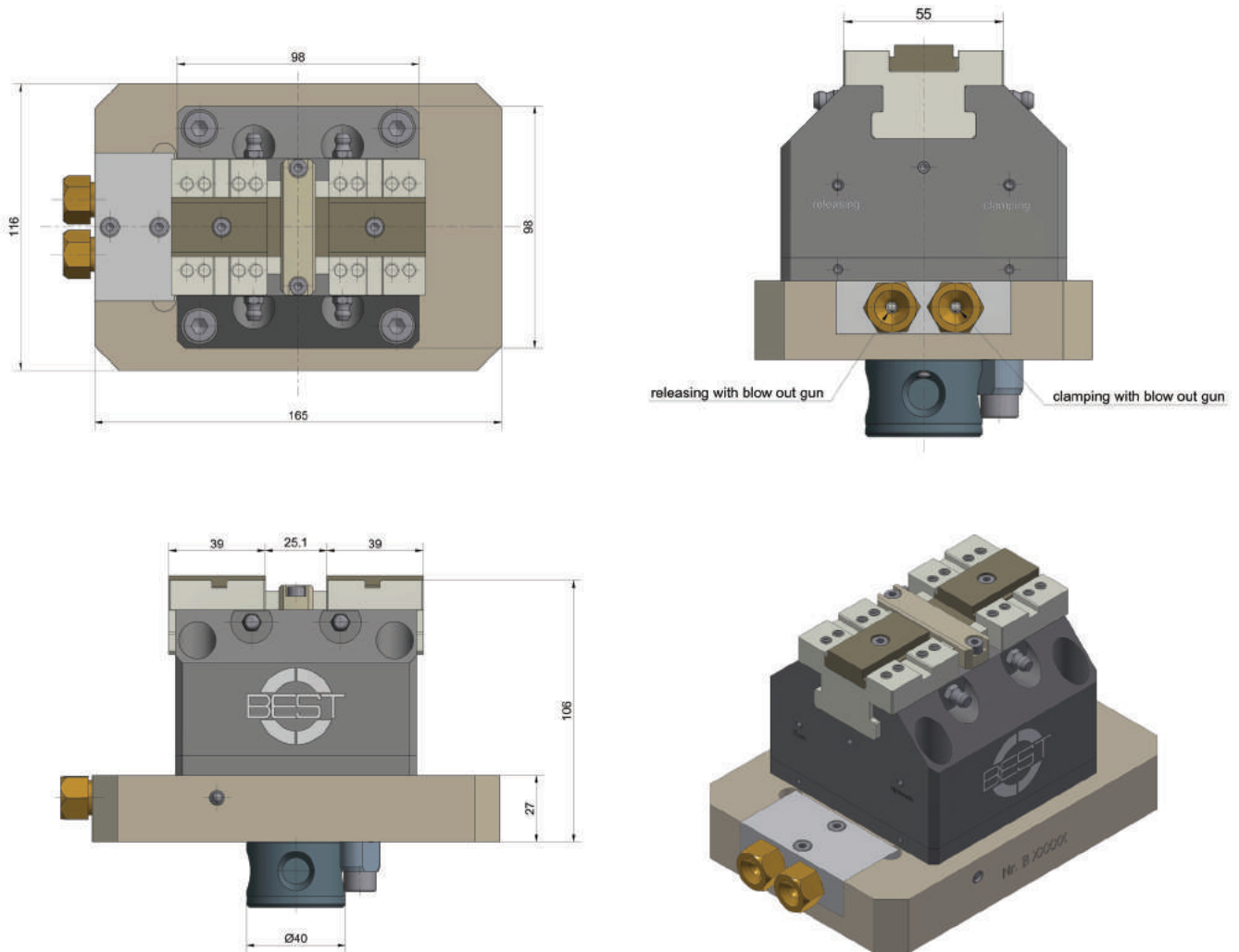

Order number: 915-0100-001

Vice BSP-100 incl. pallet with pressure maintenance valve

This solution is also possible with other vice sizes. Let us know what your requirements are and we will be happy to work out a solution for you.

5.1.2 Sample applications

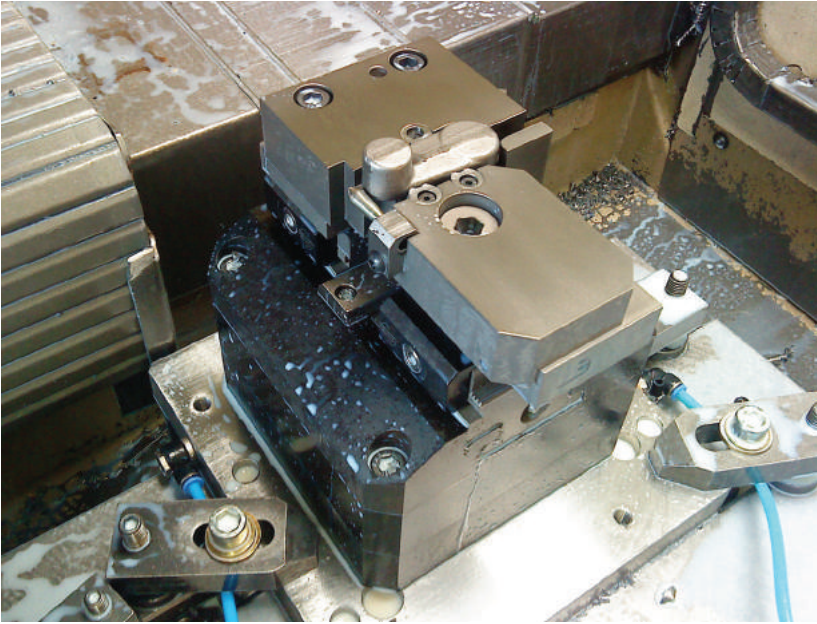

BSPD-170 with workpiece-specific jaws.
A blank cast is with large tolerance deviation is clamped. Two drill holes are set that must fit precisely to each other. The jaws have grip inserts, one jaw moves like a pendulum towards the workpiece.

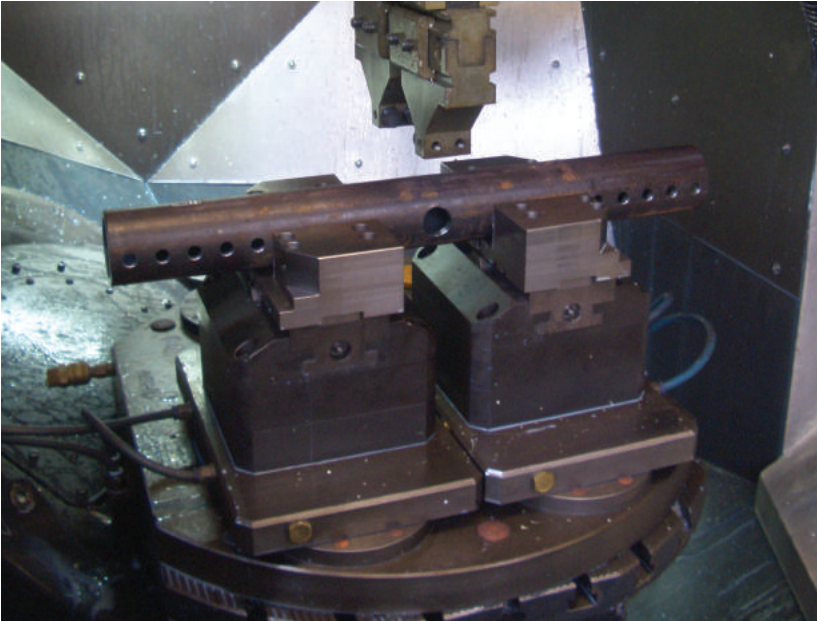

2 BSPD-170 vices clamping a shaft.
The loading takes place via a robot.

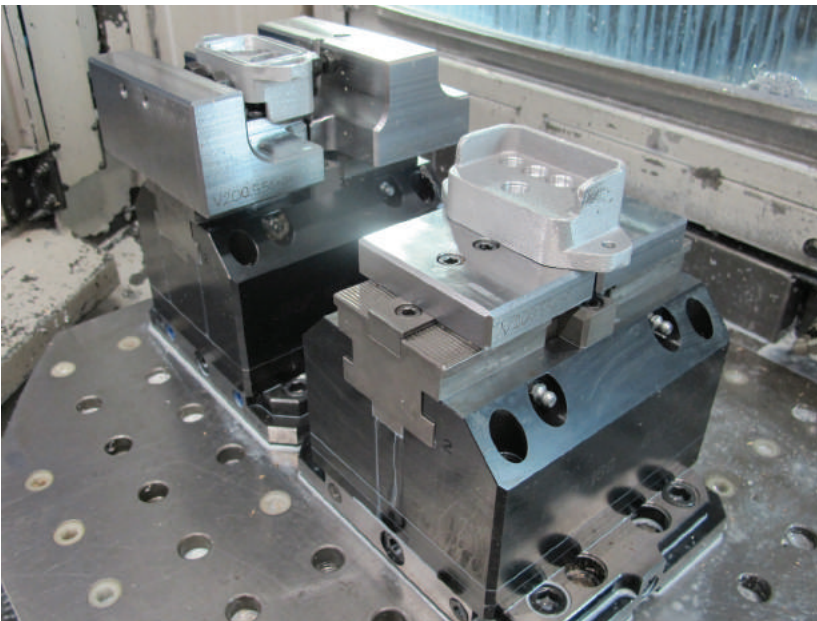

2 pieces BSP-160 with special jaws connection,
adapted to a jaws interface specified
by the customer.
The vices are mounted on a LANG zero-point plate.
Workpiece-specific jaws clamp the workpiece.

5.1.3 Pneumatic vice BSP-125-FB

Technical data:

Order number:	151-0125-001
Designation:	BSP-125-FB
Dimensions (LxWxH):	467 x 125 x 118.5 mm
Weight:	26 kg
Clamping range:	0–222 mm
Jaw lift:	3 mm
Adjustment range of clamping jaws:	114 mm
Max. actuating pressure:	9 bar
Min. actuating pressure:	1 bar
Max. clamping force:	54 kN at 9 bar
Air consumption (6 bar)	5200 cm ³ per double stroke
Jaw connection:	Tongue and groove
Air connections:	on the side

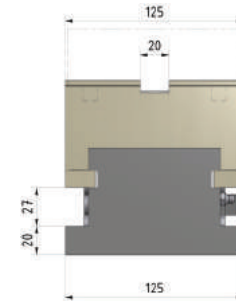
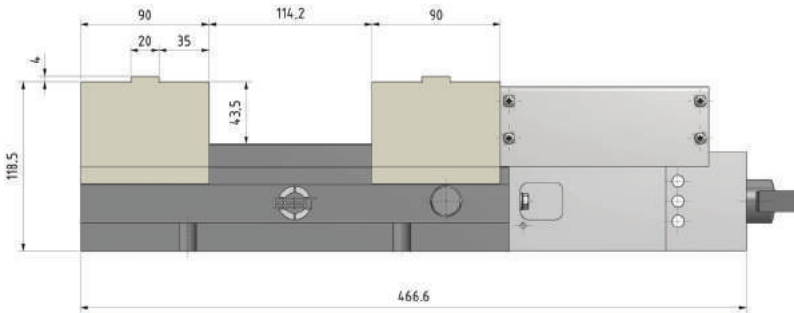
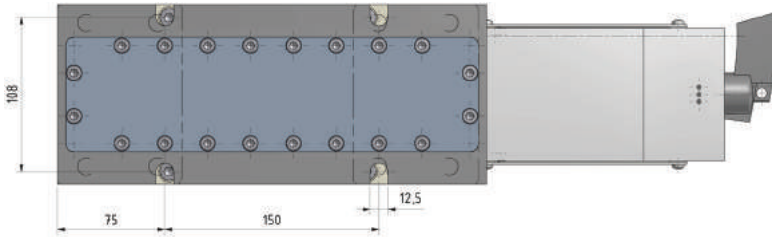
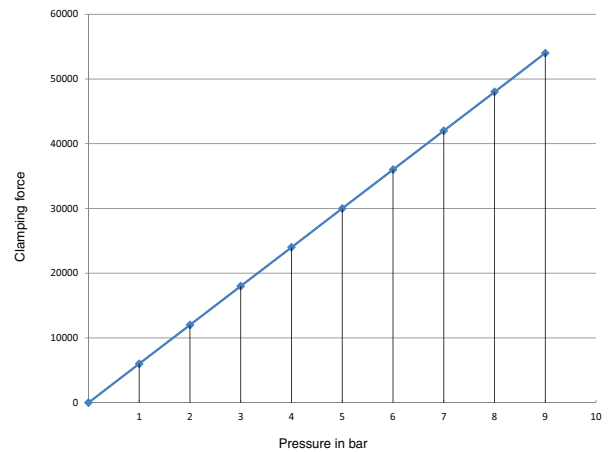

Chart clamping force BSP-125-FB



Matching stepped jaws:

Order number:	301-0125-012
Dimensions (WxLxH):	87 x 125 x 40 mm Level with 52 x 20 (WxH)



Matching blank jaw:

Order number:	301-0125-011
Dimensions (WxLxH):	125 x 87 x 50 mm
Material:	16 MnCr5

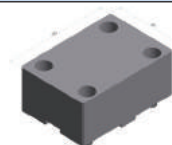

Principle of function:

- Vice with fixed jaw
- Articulate clamping jaw is roughly pre-set via a threaded spindle
- Through compressed air clamping is carried out via sluice valve and clamping lever
- Adjustment area via spindle is 114 mm. Jaw lift via compressed air 3 mm
- **No compressed air is necessary during the processing**
- Tension pressure is maintained through self-attenuation

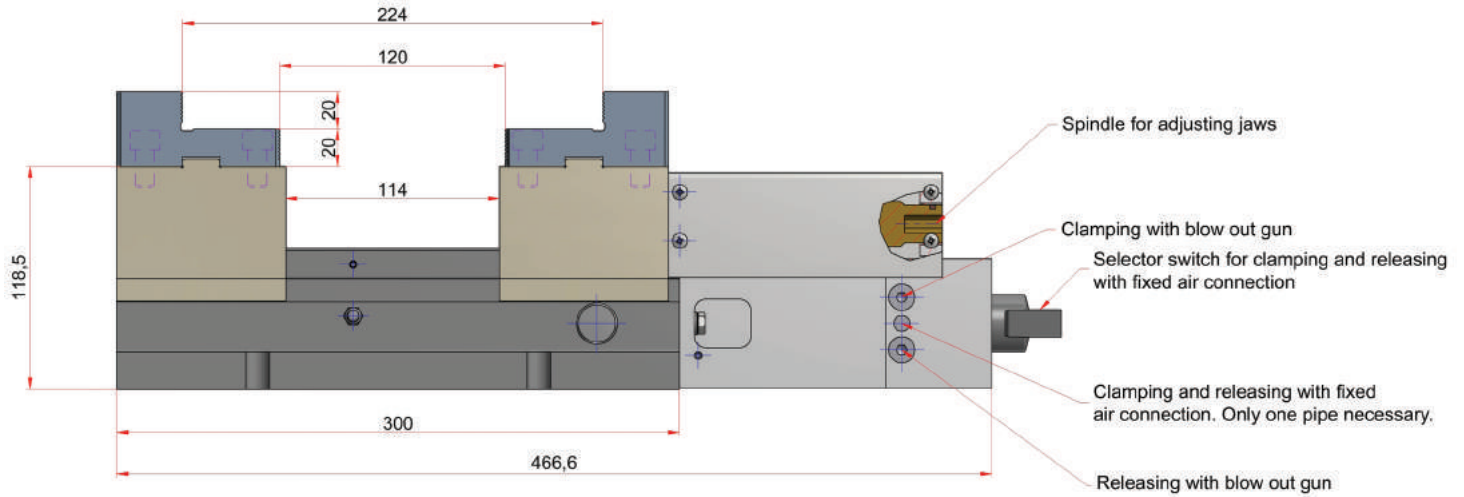

Application options:

Interior clamping, exterior clamping, parallel clamping, installation aid at the workstation

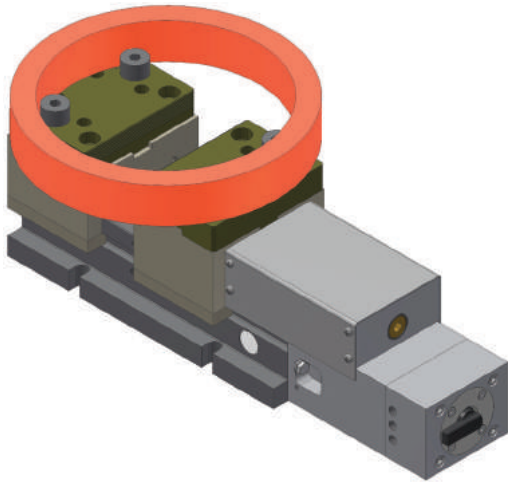

Interior clamping

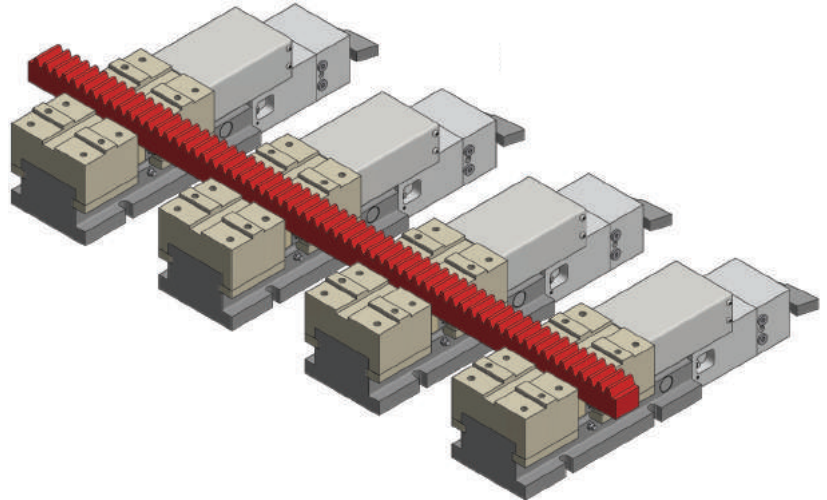

Parallel clamping

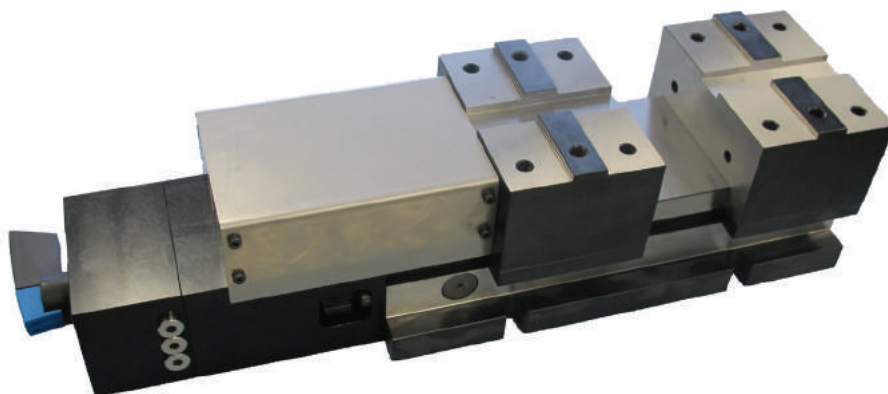

5.2. Hydraulic vice models

5.2.1 Hydraulic centric vices

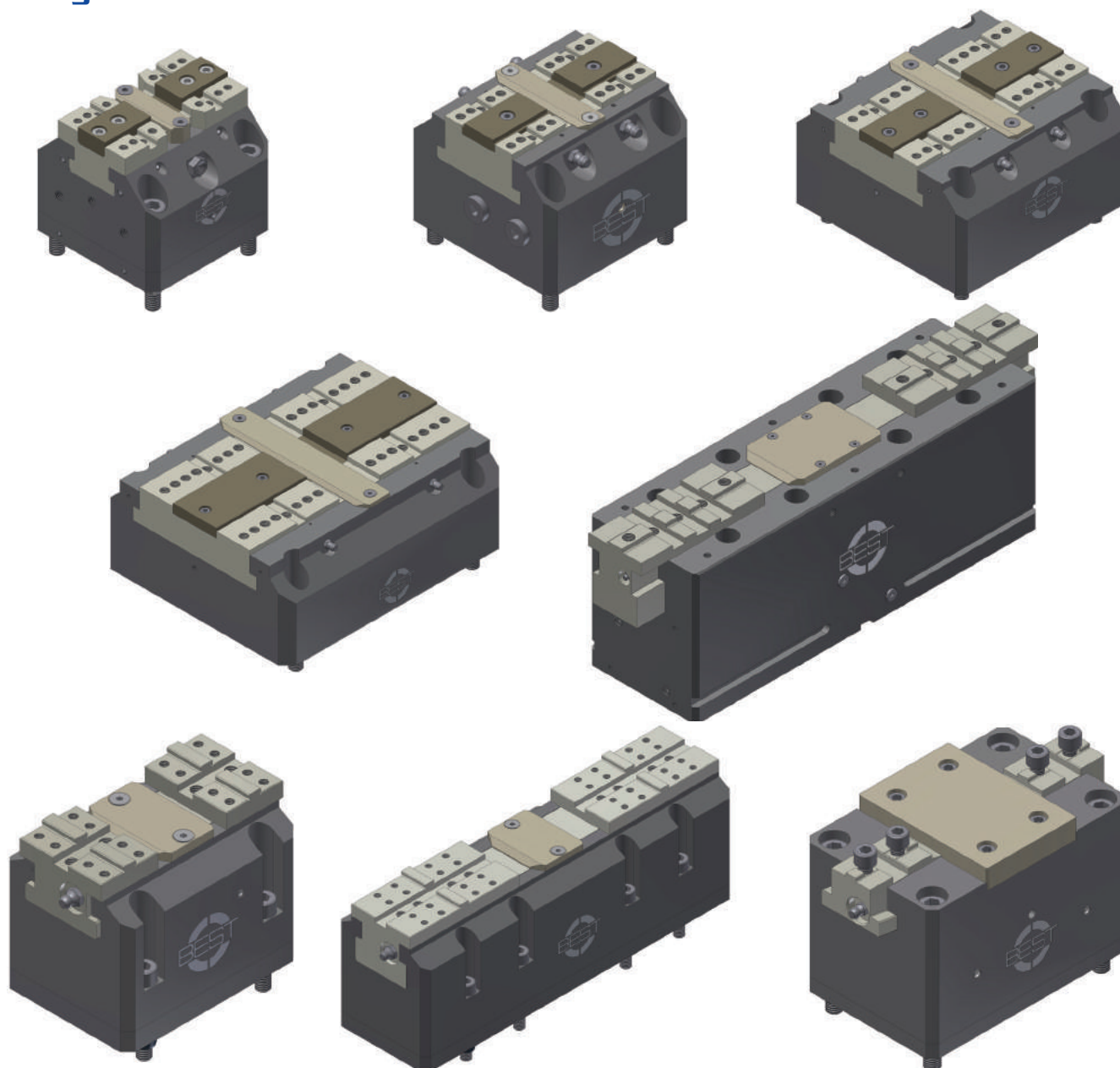

Advantages of the BEST hydraulic vices:

- Extremely high rigidity as a result of solid design
- Extremely high clamping forces (up to 50 kN)
- Housing sizes from 64 mm to 500 mm
- Repetition accuracy of 0.005 mm (with ground-in jaws)
- Centring accuracy of +/- 0.01 mm (with ground in jaws)
- Jaw widths of up to 500 mm
- Low wear due to nitrogen-hardened surfaces
- Suitable for internal or external clamping
- Individual special solutions / customer-specific customisations available on request (Please provide us with the specific data for your application, and we will send you a technical draft together with an offer for the number of items you require)

5.2.1.1 Hydraulic centric vice BSH-64

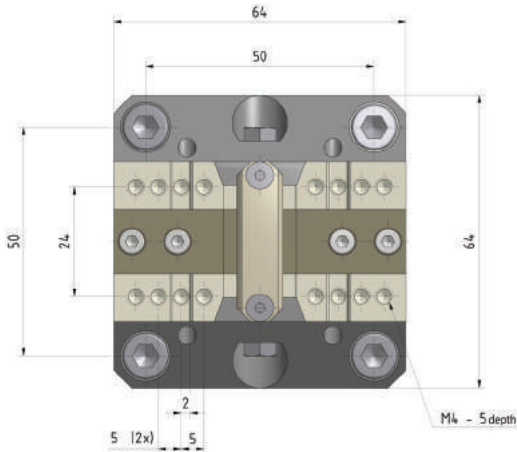
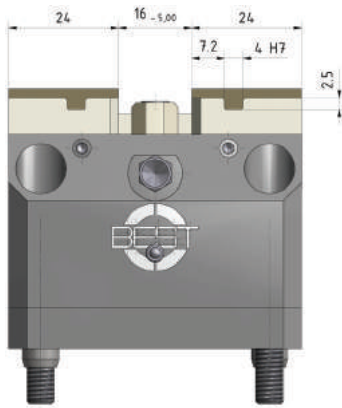
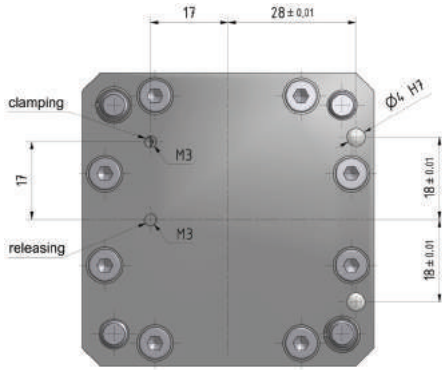

Technical data:

Order number:	100-0064-001
Designation:	BSP-64
Dimensions (LxWxH):	64 x 64 x 55 mm
Weight:	1.4 kg
Clamping range:	0–55 mm
Stroke per jaw:	2.5 mm
Max. actuating pressure:	65 bar
Min. actuating pressure:	5 bar
Max. clamping force:	4.8 kN
Stroke volume:	6 cm ³ per double stroke
Jaw connection:	Tongue and groove
Hydraulic connections:	On the side and underside

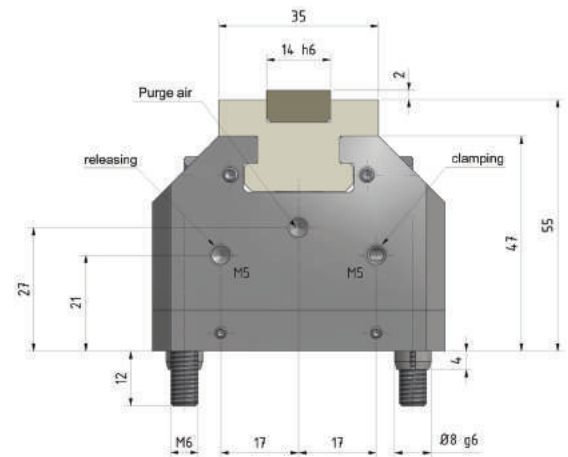
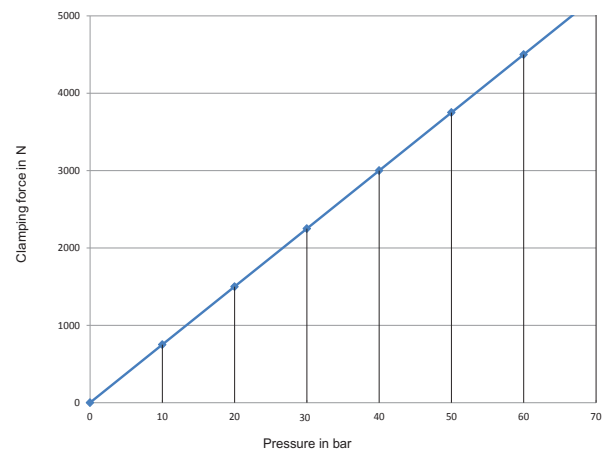

Chart clamping force BSH-64



Optional additional functions:

- Clamping path monitoring
- Fixed jaw
- Central lubrication system
- Sealing air

See optional additional functions, page 77.

Please let us know, if you require one of the additional functions, so that we can take this into consideration in the offer.

Matching blank jaw:

Order number:	301-0034-001
Dimensions (WxLxH):	36 x 29 x 18 mm
Material:	16 MnCr5

Seal set (for maintenance):

Order number:	100,300,064
---------------	-------------

5.2.1.2 Hydraulic centric vice BSH-100

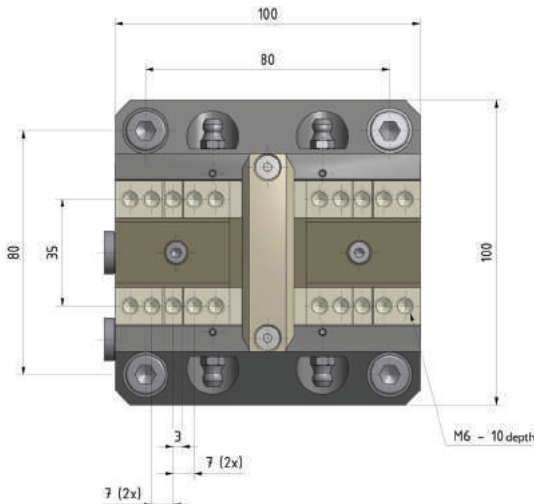
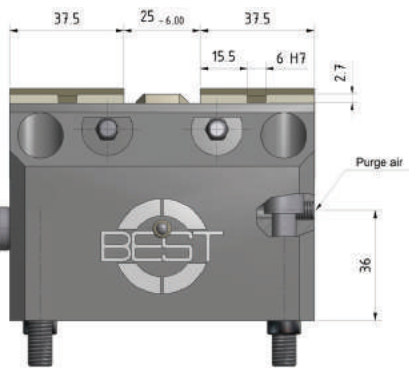
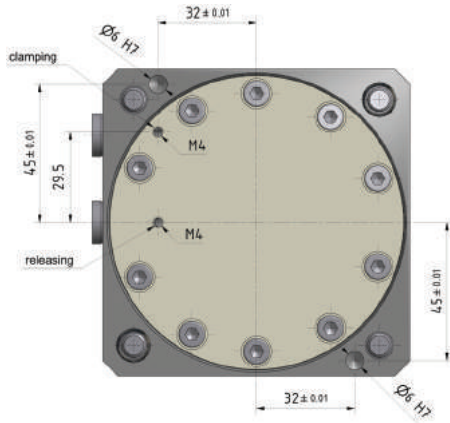

Technical data:

Order number:	100-0100-001
Designation:	BSP-100
Dimensions (LxWxH):	100 x 100 x 74 mm
Weight:	5 kg
Clamping range:	0–90 mm
Stroke per jaw:	3 mm
Max. actuating pressure:	90 bar
Min. actuating pressure:	5 bar
Max. clamping force:	20.25 kN
Stroke volume:	19 cm ³ per double stroke
Jaw connection:	Tongue and groove
Hydraulic connections:	On the side and underside

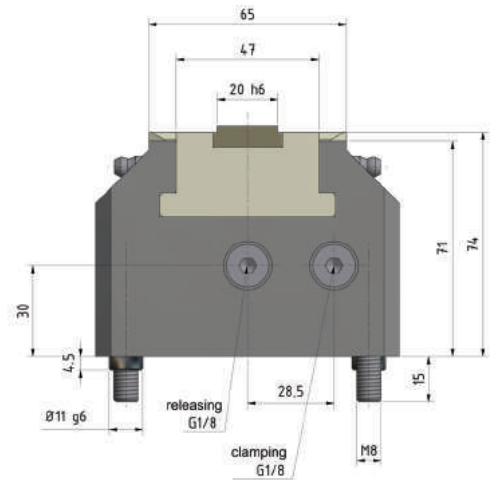
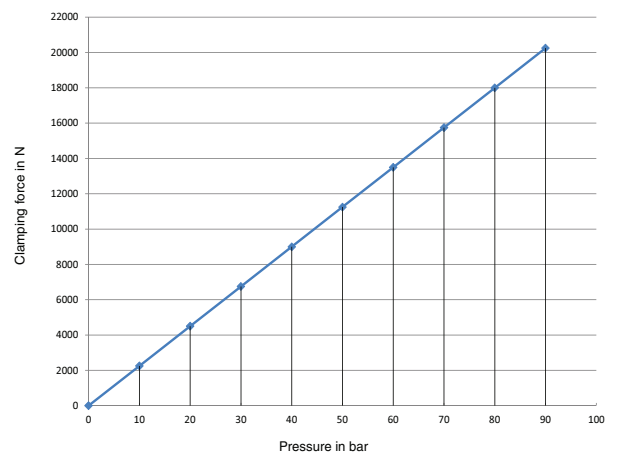

Chart clamping force BSH-100



Optional additional functions:

- Clamping path monitoring
- Central lubrication system
- Fixed jaw
- Sealing air

See optional additional functions, page 77.

Please let us know, if you require one of the additional functions, so that we can take this into consideration in the offer.

Matching blank jaw:

Order number:	301-0060-002
Dimensions (WxLxH):	60 x 45 x 30 mm
Material:	16 MnCr5

Seal set (for maintenance):

Order number:	100,300,100
---------------	-------------



5.2.1.3 Hydraulic centric vice BSH-160

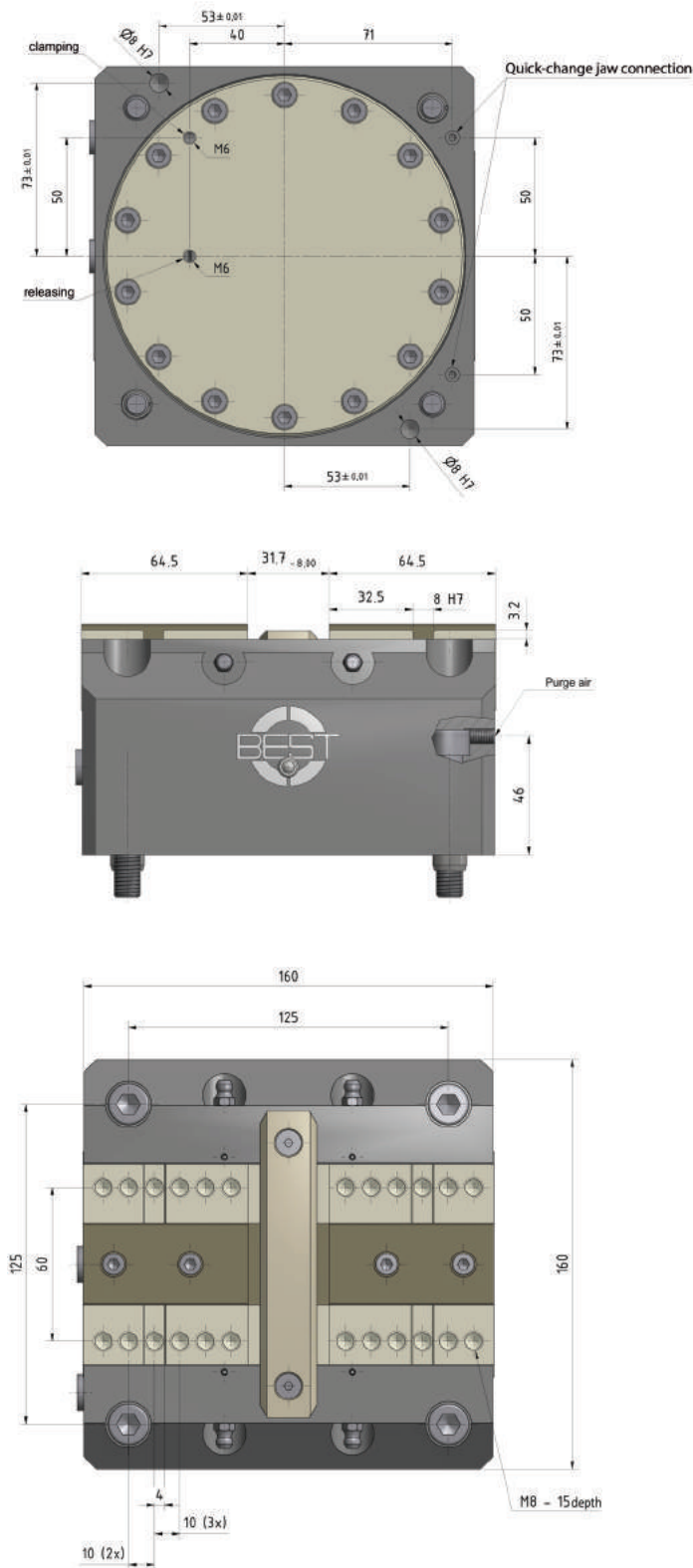

Technical data:

Order number:	100-0160-001
Designation:	BSP-160
Dimensions (LxWxH):	160 x 160 x 87 mm
Weight:	16 kg
Clamping range:	0–150 mm
Stroke per jaw:	4 mm
Max. actuating pressure:	80 bar
Min. actuating pressure:	5 bar
Max. clamping force:	47 kN
Stroke volume:	65 cm ³ per double stroke
Jaw connection:	Tongue and groove
Hydraulic connections:	On the side and underside

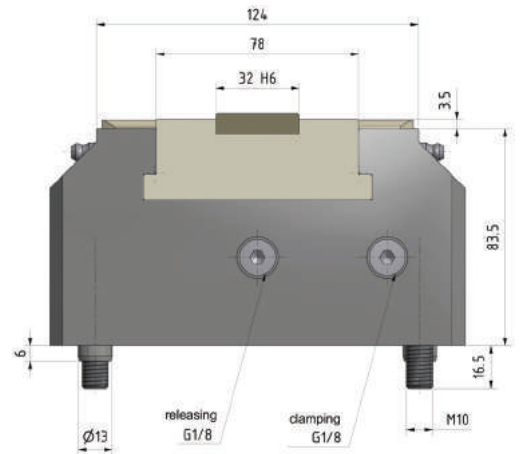
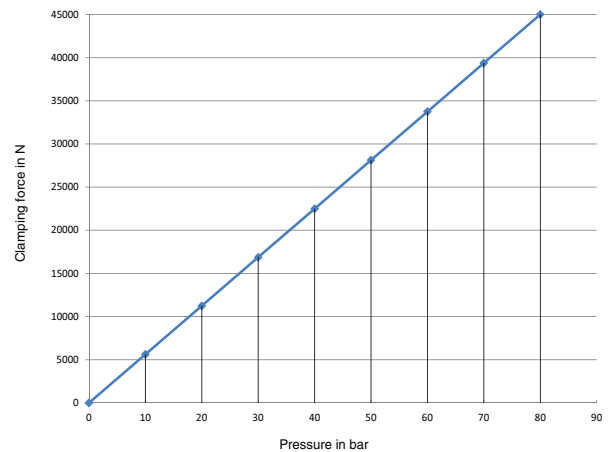

Chart clamping force BSH-160



Optional additional functions:

- Clamping path monitoring
- Fixed jaw
- Central lubrication system
- Sealing air

See optional additional functions, page 77.

Please let us know, if you require one of the additional functions, so that we can take this into consideration in the offer.

Matching blank jaw:

Order number:	301-0094-008
Dimensions (WxLxH):	94 x 67 x 50 mm
Material:	16 MnCr5

Seal set (for maintenance):

Order number:	100,300,160
---------------	-------------

5.2.1.4 Hydraulic centric vice BSH-250

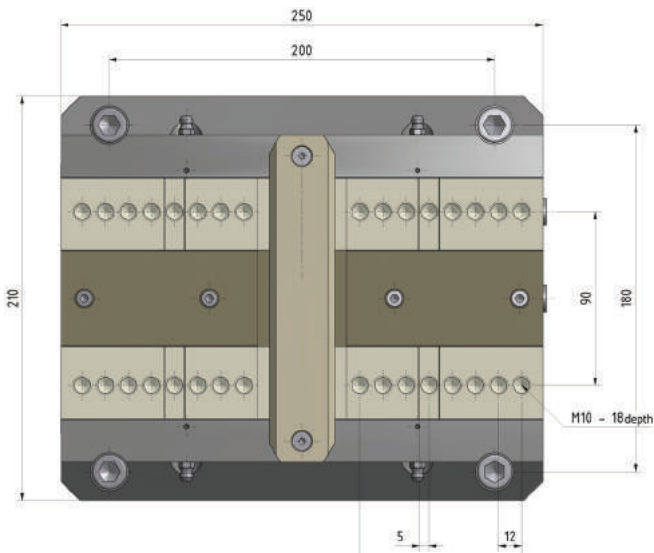
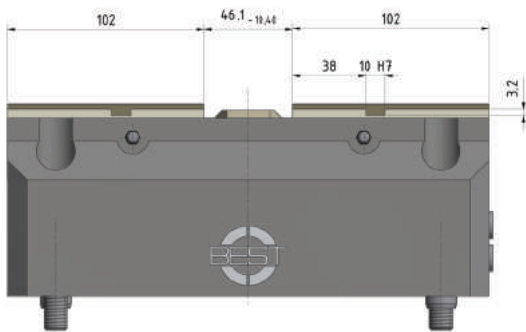
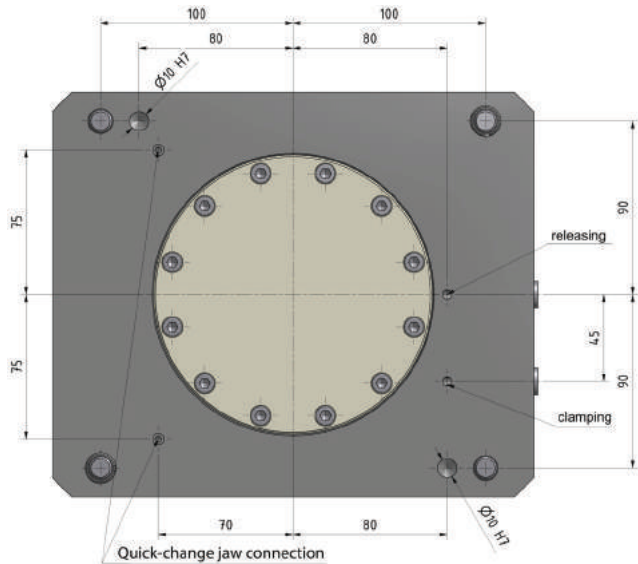

Technical data:

Order number:	100-0250-002
Designation:	BSP-250
Dimensions (LxWxH):	210 x 250 x 97 mm
Weight:	35 kg
Clamping range:	0–240 mm
Stroke per jaw:	5.2 mm
Max. actuating pressure:	90 bar
Min. actuating pressure:	5 bar
Max. clamping force:	78 kN at 90 bar
Stroke volume:	121 cm ³ per double stroke
Jaw connection:	Tongue and groove
Hydraulic connections:	On the side and underside

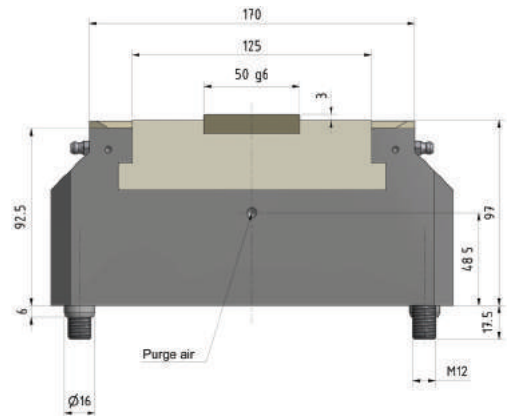
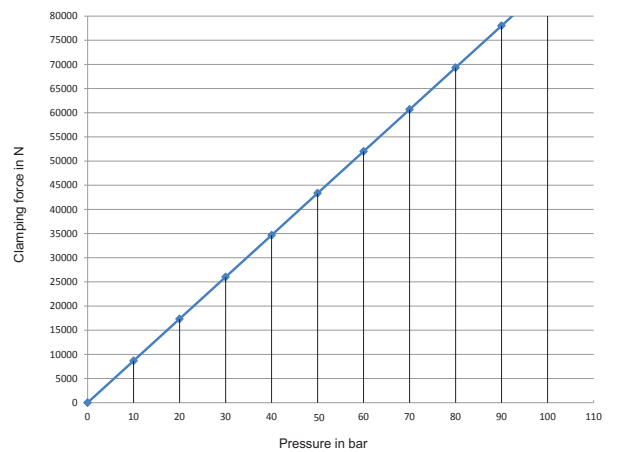

Chart clamping force BSH-250



Optional additional functions:

- Clamping path monitoring
- Fixed jaw
- Central lubrication system
- Sealing air

See optional additional functions, page 77.

Please let us know, if you require one of the additional functions, so that we can take this into consideration in the offer.

Matching blank jaw:

Order number:	301-0125-009
Dimensions (WxLxH):	125 x 100 x 60 mm
Material:	16 MnCr5

Seal set (for maintenance):

Order number:	100,300,250
---------------	-------------

5.2.1.5 Hydraulic centric vice BSH-500

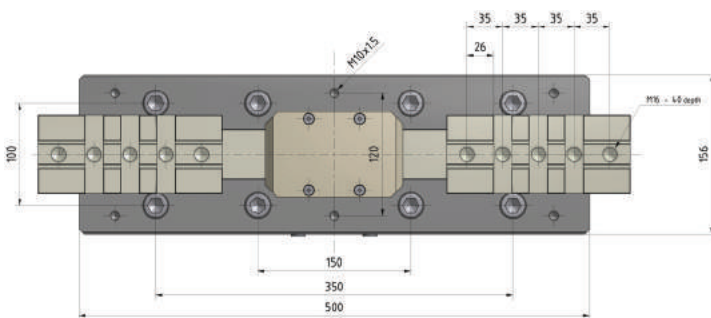
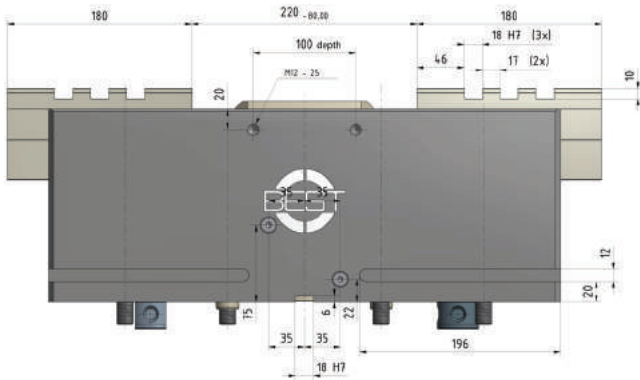
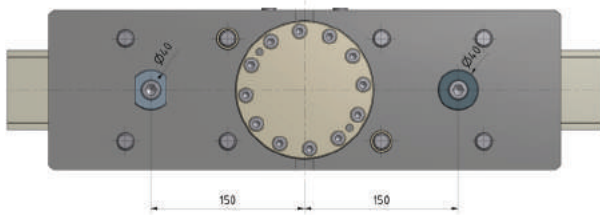

Technical data:

Order number:	100-0500-001
Designation:	BSP-500
Dimensions (LxWxH):	500 x 156 x 204 mm
Weight:	111 kg
Clamping range:	0–500 mm
Stroke per jaw:	40 mm
Max. actuating pressure:	140 bar
Min. actuating pressure:	5 bar
Max. clamping force:	72 kN at 140 bar
Stroke volume:	578 cm ³ per double stroke
Jaw connection:	Tongue and groove
Hydraulic connections:	On the side, with hydraulic control unit

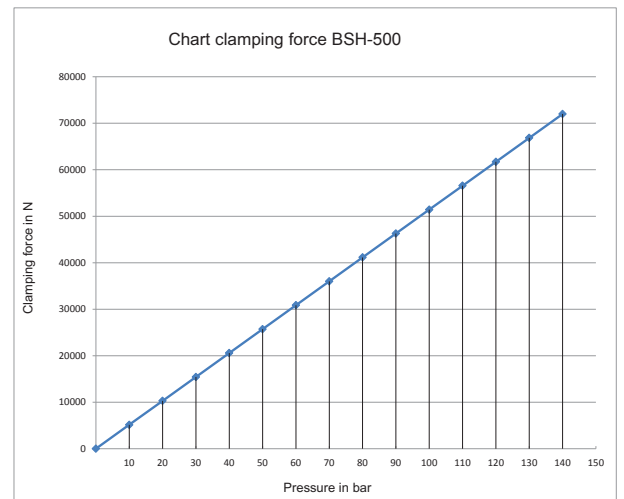
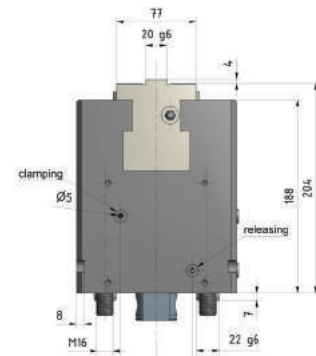

Optional additional functions:

- Clamping path monitoring
- Central lubrication system
- Fixed jaw
- Sealing air

See optional additional functions, page 77.

Please let us know, if you require one of the additional functions, so that we can take this into consideration in the offer.

Matching blank jaw:

Order number:	301-0150-008
Dimensions (WxLxH):	180 x 150 x 70 mm
Material:	16 MnCr5

Seal set (for maintenance):

Order number:	100,300,500
---------------	-------------

5.2.1.6 Hydraulic centric vice special size BSH-116

Technical data:

Order number:	100-0116-001
Designation:	BSP-116
Dimensions (LxWxH):	116 x 84 x 94 mm
Weight:	6 kg
Clamping range:	0 – 100 mm
Stroke per jaw:	6 mm
Max. actuating pressure:	140 bar
Min. actuating pressure:	5 bar
Max. clamping force:	17.5 kN at 140 bar
Stroke volume:	23 cm ³ per double stroke
Jaw connection:	Tongue and groove
Hydraulic connections:	On the underside

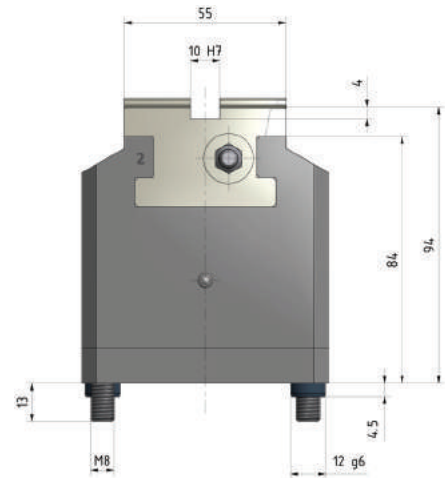
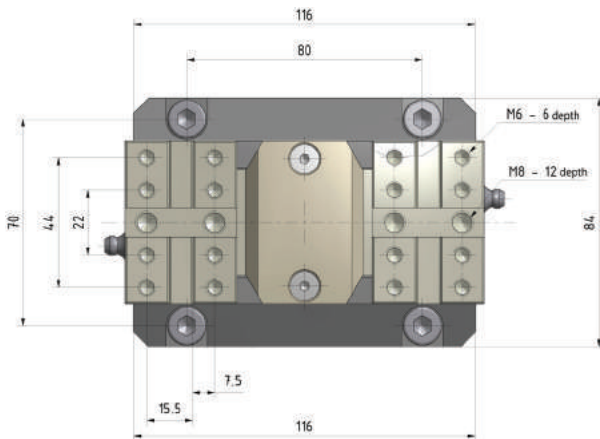
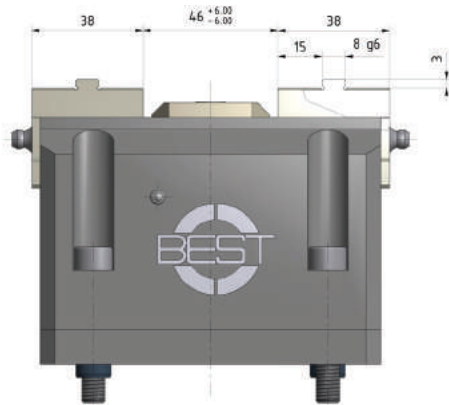
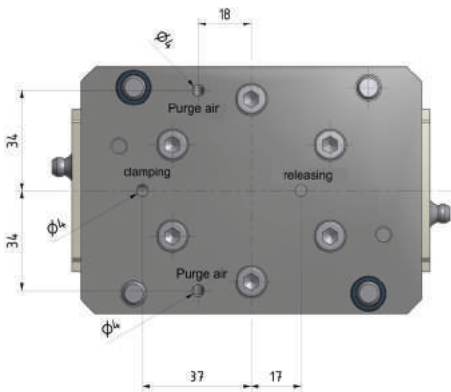
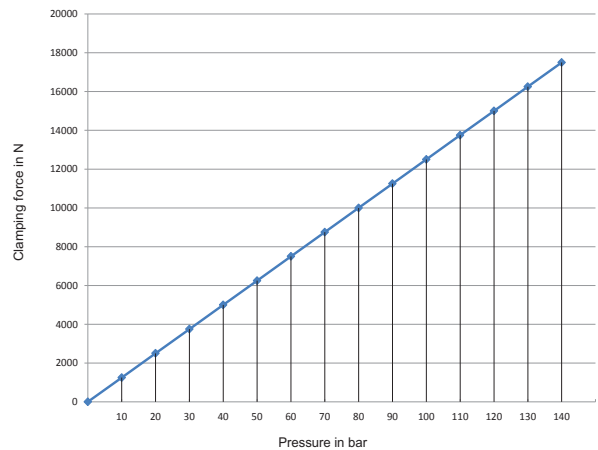

Chart clamping force BSH-116



Optional additional functions:

- Clamping path monitoring
- Fixed jaw
- Sealing air

See optional additional functions, page 77.

Please let us know, if you require one of the additional functions, so that we can take this into consideration in the offer.

Matching blank jaw:

Order number:	301-0070-005
Dimensions (WxLxH):	70 x 50 x 50 mm
Material:	16 MnCr5

Seal set (for maintenance):

Order number:	100,300,116
---------------	-------------



5.2.1.7 Hydraulic centric vice special size BSH-290

Vice with extra long stroke

Technical data:

Order number:	100-0290-001
Designation:	BSP-290
Dimensions (LxWxH):	290 x 84 x 104 mm
Weight:	17 kg
Clamping range:	0–250 mm
Stroke per jaw:	15 mm
Max. actuating pressure:	150 bar
Min. actuating pressure:	5 bar
Max. clamping force:	11 kN at 150 bar
Stroke volume:	23 cm ³ per double stroke
Jaw connection:	Tongue and groove
Hydraulic connections:	On the underside

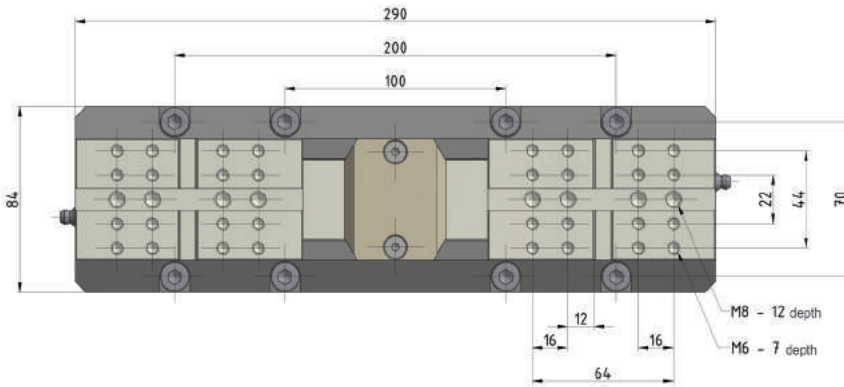
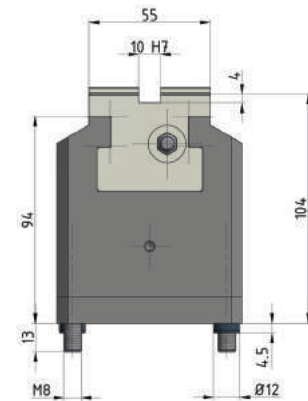
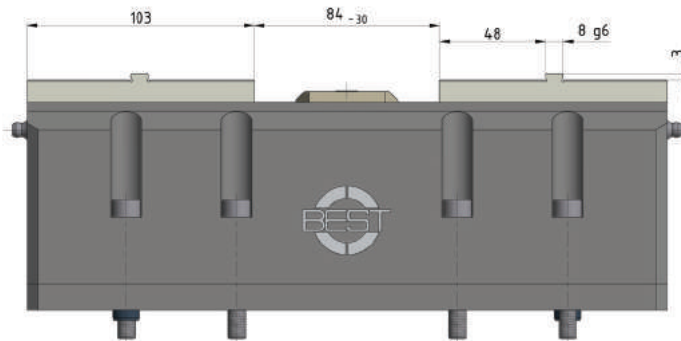
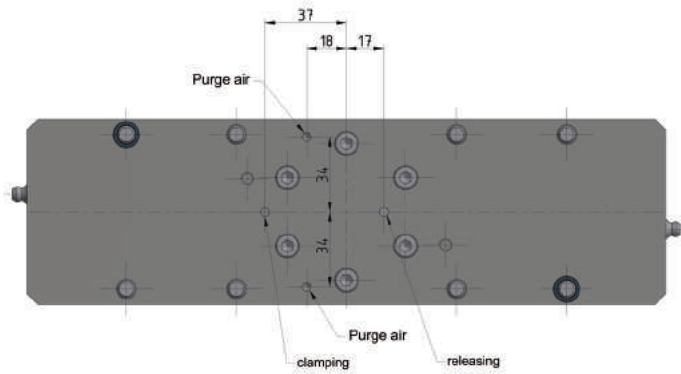
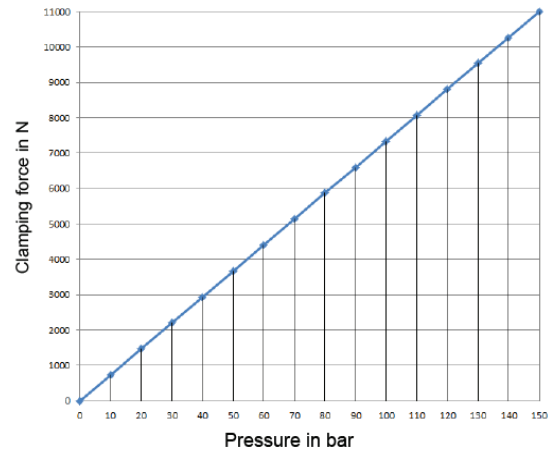

Chart clamping force BSH-290



Optional additional functions:

- Clamping path monitoring
- Fixed jaw
- Sealing air

See optional additional functions, page 77.

Please let us know, if you require one of the additional functions, so that we can take this into consideration in the offer.

Matching blank jaw:

Order number:	301-0100-014
Dimensions (WxLxH):	130 x 100 x 50 mm
Material:	16 MnCr5

Seal set (for maintenance):

Order number:	100,300,116
---------------	-------------

5.2.2 Hydraulic compensation vice BSHAN-155

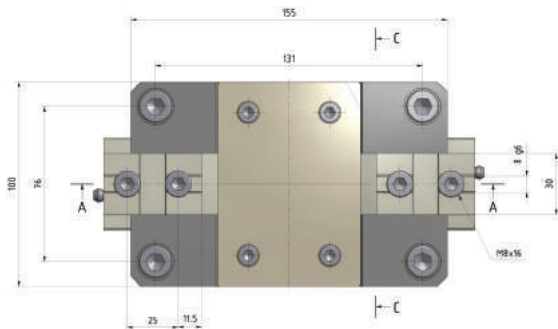
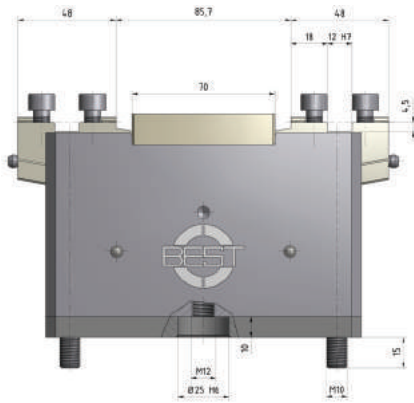
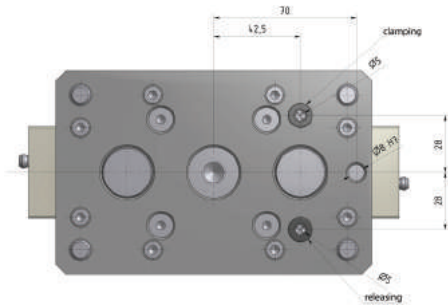

Technical data:

Order number:	102-0155-001
Designation:	BSHAN-155
Dimensions (LxWxH):	155 x 100 x 105 mm
Weight:	12 kg
Clamping range:	0 – 100 mm
Stroke per jaw:	2.6 mm
Clamping compensation:	2 mm
Max. actuating pressure:	140 bar
Min. actuating pressure:	5 bar
Max. clamping force:	32 kN at 140 bar
Holding force:	30 kN
Setting force of the jaw:	30 N
Stroke volume:	26 cm ³ per double stroke
Jaw connection:	Tongue and groove
Hydraulic connections:	On the underside

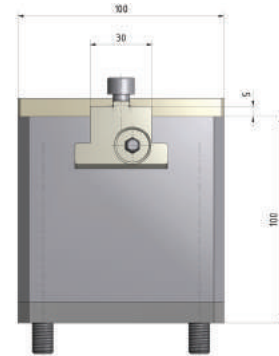
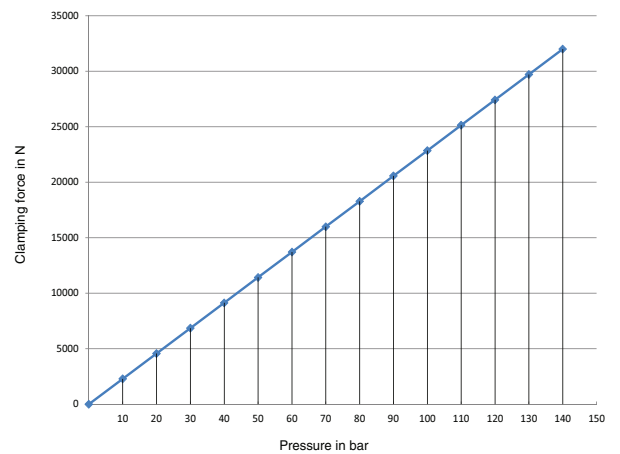

Chart clamping force BSHAN-155



Matching blank jaw:

Order number:	301-0050-009
Dimensions (WxLxH):	50 x 50 x 45 mm
Material:	16 MnCr5

Seal set (for maintenance):

Order number:	100,302,155
---------------	-------------

Principle of function:

- Workpiece with reference drill holes or reference areas is placed onto the workpiece fixation device of the vice
- First, the first jaw floats onto the workpiece (setting force max. 30 N), and after that the second jaw
- When both jaws abut against the workpiece, the pressure is built up (holding force: 30 KN)
→ This allows for a compensation of dimensional deviations of the blank workpieces.
- The slanted jaw guide line creates a pull-down effect, which pushes the workpiece onto the support

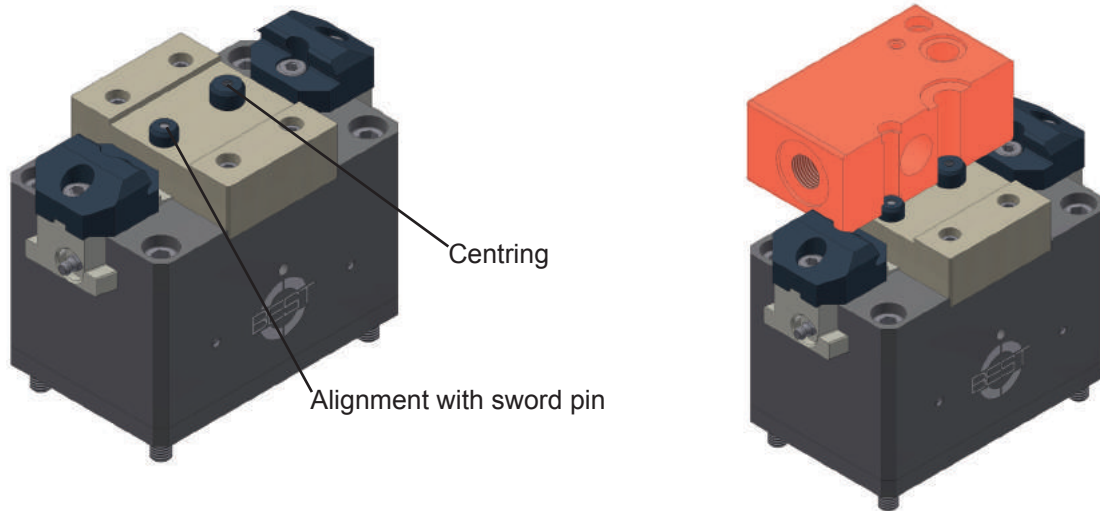

Application options:

- For clamping workpieces with dimensional deviations of up to 2 mm (e.g. cast parts)

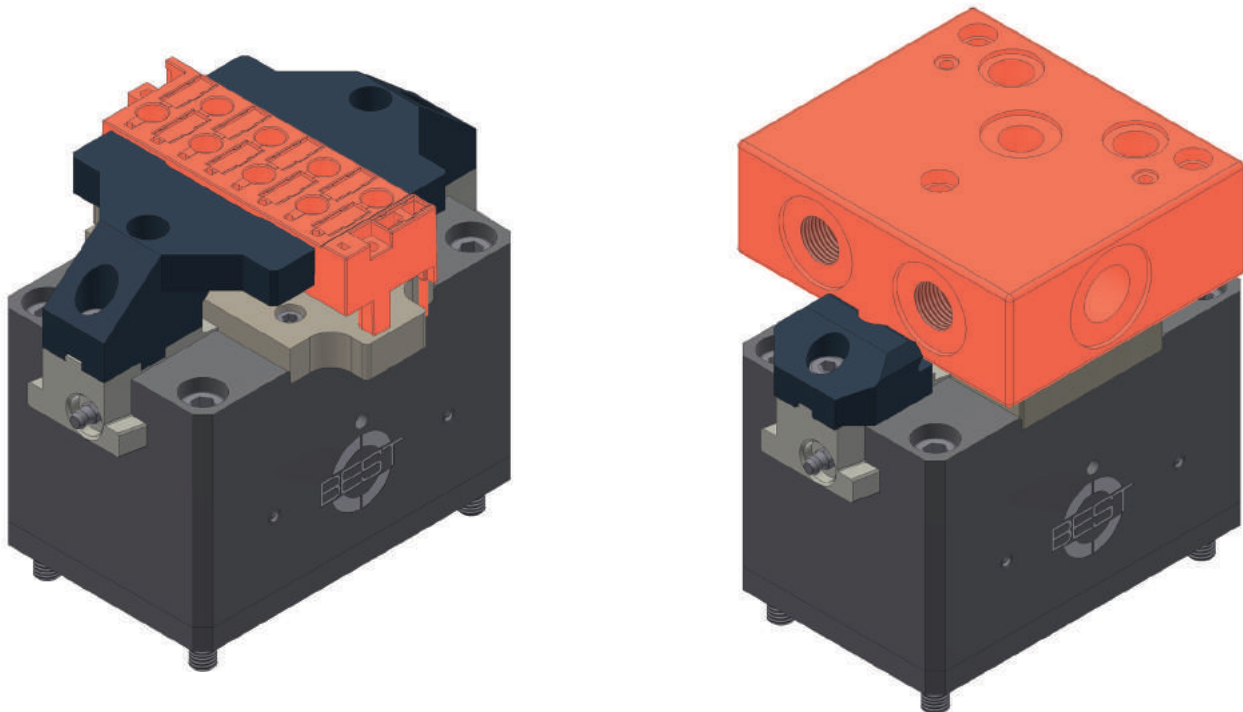

Please send us your workpiece that needs to be clamped (ideally the Step format), and we will gladly send you a technical draft together with an offer for the number of items you require.

5.2.3 Sample applications

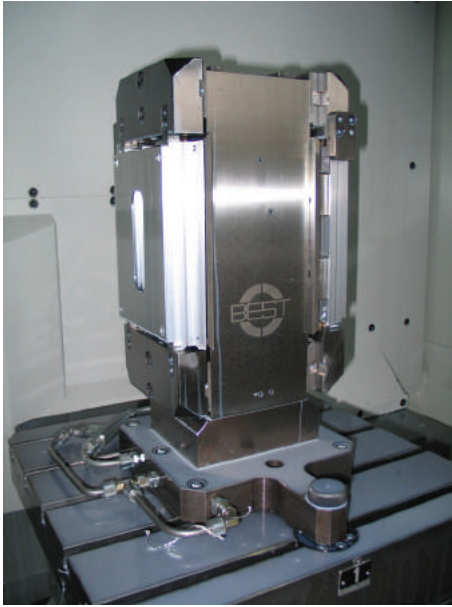

Customer-specific special solution.
Since space on the machine is limited, a solution with tombstone and two hydraulic vices was not an option.
For that reason, the clamping device with two-sided clamping was developed.

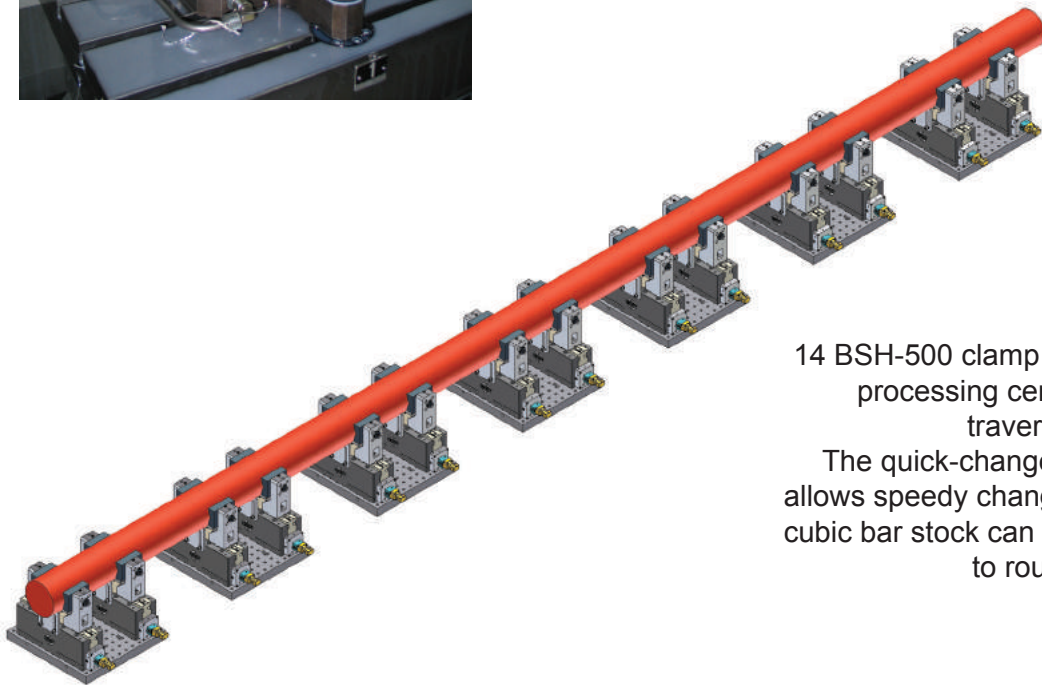

14 BSH-500 clamp a shaft in a long profile processing centre with 8000 mm traversing path.
The quick-change system for the jaws allows speedy changeover. This means that cubic bar stock can be machined in addition to round stock.

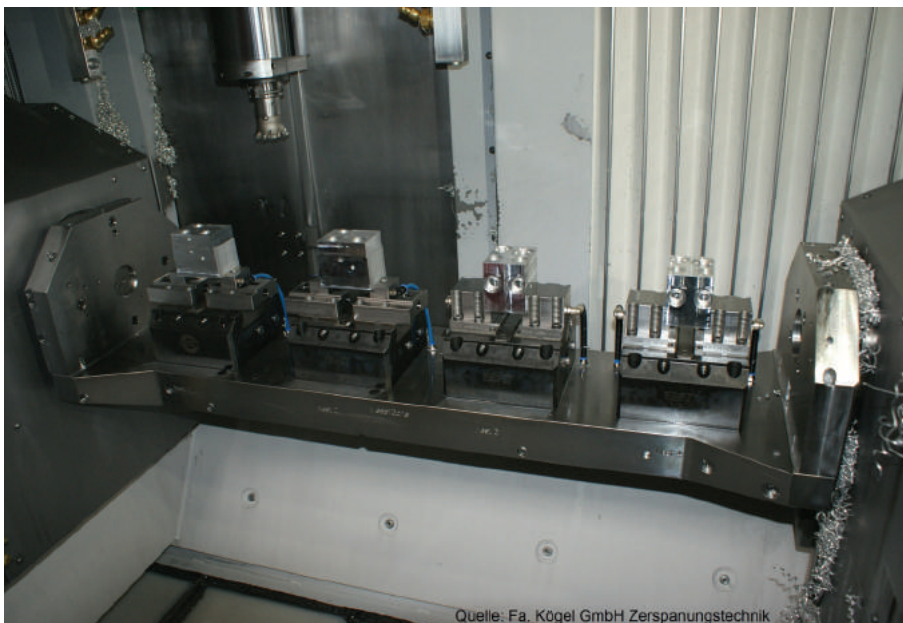

4 BSH-160 on a swivelling bridge with workpiece-specific jaws.

Quelle: Fa. Kögel GmbH Zerspanungstechnik

5.3 Optional additional functions for automated centric vices

The pneumatic and hydraulic centric vices can be equipped with various additional functions. The additional functions that are possible for the respective devices can be found in the corresponding description of the vice in this catalogue. When you order the vice, please let us know, if you require one or several of the additional functions, so that we can prepare the vices accordingly. The additional functions are explained below.

Clamping path monitoring:

Through a clamping path monitoring query from automated devices it is possible to verify whether the workpiece has been properly inserted and clamped:

- The production only starts when the correct clamping path has been reached and the media pressure has been applied
- Any number of reference values of the workpieces can be stored in the PLC (upper and lower tolerance values of the clamping paths)
- Clamping paths of 2 to 10 mm per jaw can be monitored
- Repetition accuracy is better than 0.05 mm under the same conditions
- Resolution/accuracy depends on the clamping path
- The solution supports the compliance with the Machinery Directive 2006/42/EC, since two separate systems are available for a secure process (clamping path and pressure)

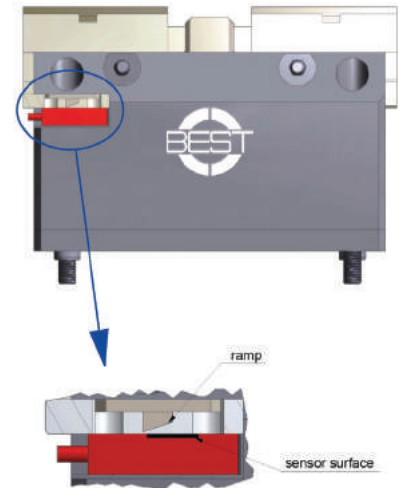

Tracking control:

An airflow is guided through the contact surface of the workpiece touch point, the flow resistance arising at the workpiece touch points will be read.

If the workpiece does not touch or lifts off, the machine cannot start and the spindle will be stopped.

Sealing air:

The hydraulic and pneumatic vices of BEST can be equipped with the additional sealing air function with little effort. In this case, an overpressure is generated in the vice, which prevents dirt from entering into the vice.

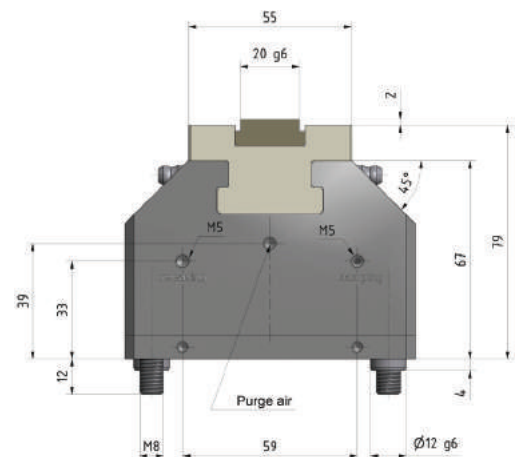

Central lubrication system:

By selecting the central lubrication option, you can reduce the maintenance expenditure of the vice. The automated and simultaneous lubrication of multiple vices is possible. The regular lubrication and correct dosing reduces the lubrication consumption and wear.

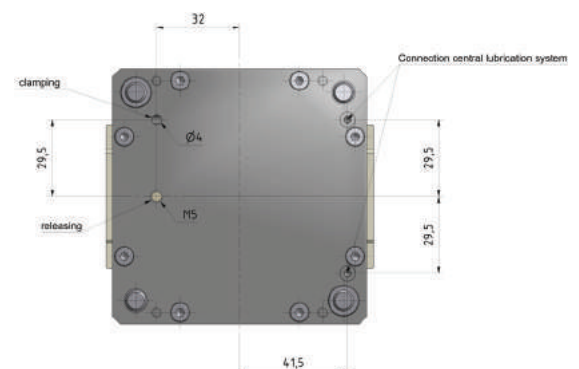

Fixed jaw:

The pneumatic and hydraulic centric vices from BEST can also be refitted to a clamping device with fixed jaw, if necessary.

Compensation function:

If you have an application that requires the jaws to adapt themselves to the different tolerances of the workpieces, the BEST vices can also be converted to compensation function.

This can be of interest, for example, if the medium vices are to serve as a clamping support only. In this case, the exterior vices must function centrically and specify the position.

RFID:

Each BEST vice (including the mechanical centric vices) can be equipped with an RFID chip. It can carry data about the clamping device, such as serial number, model, purchase date, for example.

In addition, essential information about the clamping device can also be stored. The machine can thus recognize which clamping device is being used for clamping. For various machine types it is then possible to compensate for potential deviations.

Application example clamping path monitoring:

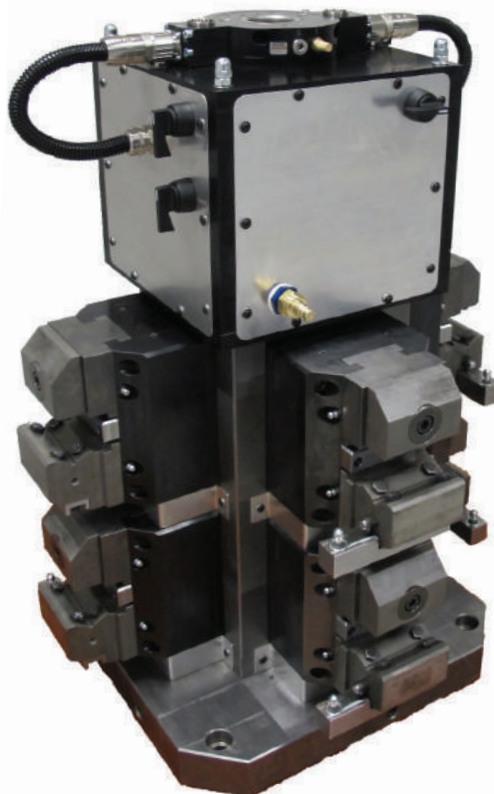

Shafts are clamped in a horizontal processing centre on a tombstone with 8 BSP-160. In this case, the vices were equipped with the additional clamping path monitoring function.

The entire control is set up in the tombstone structure.

The user can select between automatic and manual operation.

6. Multi-point clamping strips

The multi-point clamping strips are a modular system that allows you to clamp one or more workpieces to a base rail. The vice modules can be placed on the clamping rail in 2 mm intervals and secured by means of a side screw (25 Nm torque). Additional clamping positions can be easily added by attaching one or more additional clamping modules.

Order number linear embossing starter set: **420-0500-001**

Part	Order number, individual parts	Designation
1	5504-0500-001	Base rail
2	300-0094-006	Grip jaws, quick-change
3	303-0094-091	Linear embossing/stamping clamping module
4	5121-0094-003	Embossing/stamping clamping jaw
5	6303-0093-003	Parallel base
6	5062-0020-001	Magnet stop
7	DIN912 M5x20	Socket head cap bolt

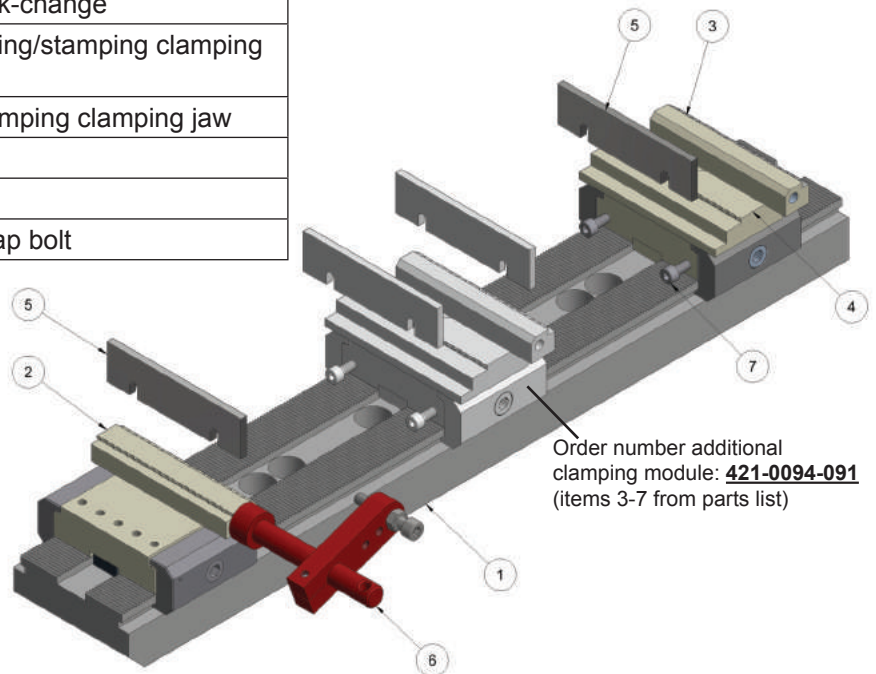

Order number linear starter set: **420-0500-002**

Part	Order number, individual parts	Designation
1	5504-0500-001	Base rail
2	300-0070-003	Stop module
3	303-0048-090	Linear clamping module
4	5121-0048-001	Clamping jaw, smooth
5	6303-0047-002	Parallel base
6	5062-0012-009	Stop
7	DIN912 M5x20	Socket head cap bolt

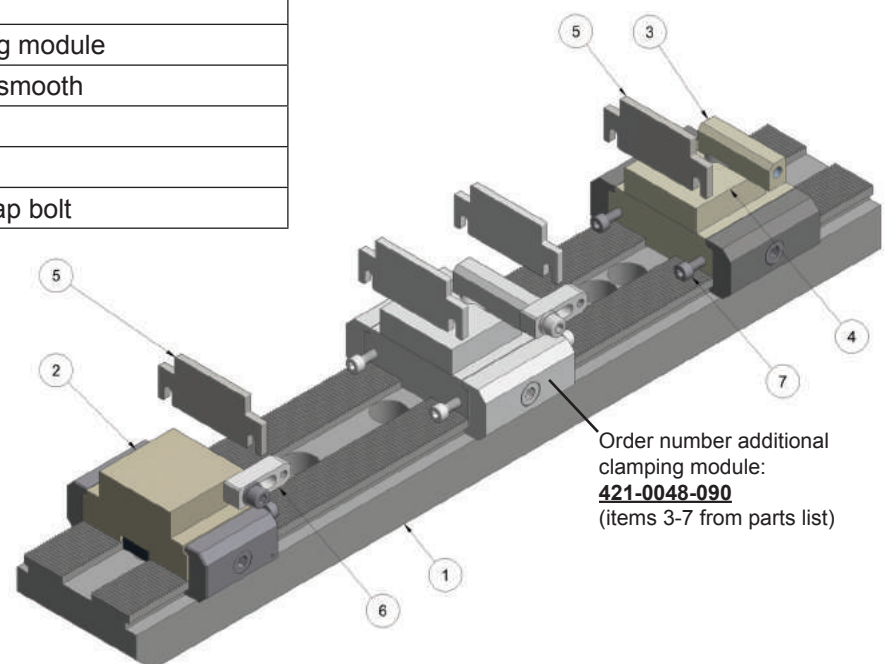

Different lengths and sizes of the multi-point clamping strips are available on request.
Different jaw designs (also draw-down modules) are available on request.

7. Customer-specific solutions

You have a workpiece that you would like to clamp and need help with the implementation?
With BEST you have come to the right place!

Please send us your workpiece that needs to be clamped (ideally the stepped format), and let us know which processing procedures you would like to carry out in the desired clamping position. Upon submission of the relevant machine data and information of the desired clamping method (mechanical, pneumatic or hydraulic), our experienced engineers will develop an individual proposal for you.

BEST standard material will be used for that if possible. If special material as required, we can support that even for smallest quantities.

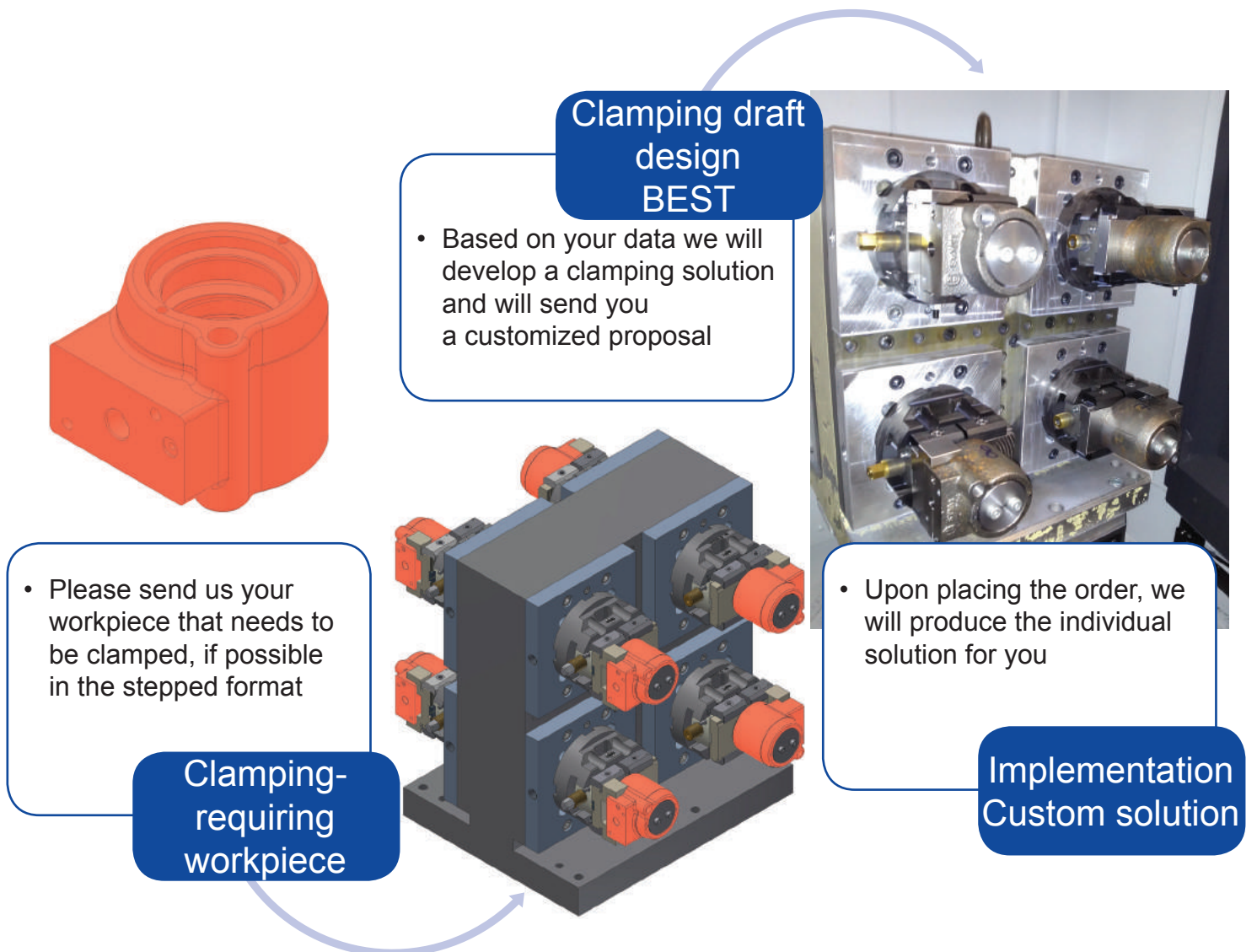

The illustrated example is an application at LUKAS Hydraulik GmbH.

8 mechanical centric vices RPC-140 are mounted via a zero-point plate with the BEST zero point system on a double bracket that is already available at the company.

A component for a hydraulic rescue aggregate is clamped with workpiece-specific jaws that were manufactured from the blank jaws 300-0094-002.

8. Hugo Reckerth GmbH fi Spindelbau

The Hugo Reckerth GmbH is family-owned business that has grown over many years, with headquarters in Filderstadt-Bonlanden and is managed under one roof with the BEST GmbH. Reckerth develops and manufactures highly precise spindles for milling, drilling, turning, and grinding machines utilized in wood, plastic, and metal-processing commercial applications. With more than 30 years of experience the company is one of the international quality providers in the spindle manufacturing industry.

Even if you only need a relatively small quantity, we are your partner for custom solutions and innovative spindles. Our technology puts us on the technology leader board, while our midsize operation enables us to quickly respond to your individual requests.

Our state-of-the-art production equipment puts us in a position to flexibly respond to new market requirements.

Range of services:

- Electric and motor spindles
- Complete 5-axis milling heads
- Belt spindles
- Motors for test bays
- Repair service
- Drilling oil feed apparatus (BOZA)

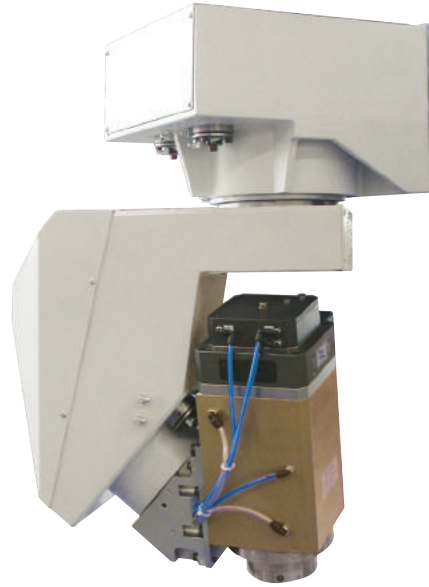

If you have any questions regarding our products or require personal assistance, we would be delighted to hear from you and will be glad to assist you.

Hugo Reckerth GmbH
Spindle & Balancing Technology
Raiffeisenstrasse 15
D-70794 Filderstadt-Bonlanden
Phone +49 (0)711 / 722579-0
Fax +49 (0)711 / 722579-29
info@reckerth.de
www.reckerth.de



Hugo Reckerth GmbH



General Terms and Conditions, Best GmbH

Modular clamping technology & automation

1. General information

- (1) These general terms and conditions apply to business dealings with other companies; they apply exclusively unless other agreements. Unless we have expressly agreed to accept them, we do not recognise any terms and conditions of the customer's company which are contrary to or deviate from these General Terms and Conditions.
- (2) Our General Terms and Conditions also apply in accordance with paragraph (1) in the course of a continued business relationship and to all future dealings with the customer.

2. Offer

- (1) Our offers are non-binding. All documents pertaining to an offer, such as illustrations, drawings, specifications of weights and dimensions, are authoritative on an approximate basis, unless they are explicitly stated as binding.
- (2) The order signed by the customer is binding. We are entitled to accept the contractual offer contained in the customer's order within three weeks of receipt of the same by us through the issuing of order confirmation or through delivery of the goods ordered.
- (3) Our written order confirmation is authoritative for the scope of the delivery. Any additional agreements and modifications to the order must be in written form.
- (4) Our sales personnel and representatives are not authorised to conclude additional oral agreements, give assurances etc. above and beyond the scope of our written order confirmation.
- (5) We retain the right of title and copyrights to all information, in particular illustrations, drawings, cost estimates and other documents made available by us to the customer or third parties. This information may not be passed on to persons other than the customer or these third parties.

3. Price and payment

- (1) The price specified in the written order confirmation is non-binding. We reserve the right to alter our prices accordingly in the event of reductions or increases in costs occurring after conclusion of the contract, in particular as the result of wage settlements or changes in the price of materials. On request, we will furnish proof of such reductions or increases in costs to the customer. Our prices are quoted without sales tax and are valid ex works and not including packaging. Sales tax at the currently valid legal rate will be listed separately in the invoice on the date of billing.
- (2) The amount of the invoice falls due on handover of the goods or on receipt of the invoice. Cash discounts must be agreed upon in written form.
- (3) Orders for payment, checks or bills of exchange will only be accepted as payment after special written agreement and will only be accepted as payment with consideration of all collection and discount fees.
- (4) The customer can only offset against our payment claims if the counterclaim of the customer is undisputed or in the case of legal entitlement. The customer is entitled to right of lien only in as far as it is based on the same contractual relationship.
- (5) Default interest of 8% p.a. above the basic interest rate will be charged. The possibility of enforcement of further claims is not excluded.

4. Delivery and delays in delivery

- (1) Delivery dates and delivery periods must be stated in writing. They are non-binding unless they are agreed upon in writing as binding. Delivery periods commence with conclusion of the contract. Where subsequent modifications to the contract are agreed upon, a new delivery date or delivery period must be agreed upon at the same time where applicable. Adherence to deadlines for deliveries and services on our part is subject to punctual receipt of all information and documents to be provided by the customer, official certification and releases, in particular plans, and the observance of the agreed conditions of payment and the fulfilment of other obligations by the customer. If these preconditions are not met, deadlines will be postponed or extended accordingly.
- (2) Delivery periods will be extended – also within the framework of an existing delivery delay – as deemed reasonable on the occurrence of unforeseen events beyond our volition and our sphere of control despite appropriate care having been exercised on our part, e.g. in the case of the disruption of operations, intervention by the authorities, problems with the power supply or delays in the delivery of essential bought-in parts. The same applies in the case of strikes and lockouts. We are under obligation to inform the customer immediately if such problems occur.
- (3) Delivery deadlines shall be considered as met if prior to deadline expiry the delivery item has left our factory or if we have informed the customer that the order is ready for shipment. If a non-binding delivery date or a non-binding delivery period is exceeded by four weeks, the customer is entitled to write to us requesting delivery within a reasonable period. When the deadline specified in this request has expired, we are in default.
- (4) In addition to delivery, the customer is entitled to claim indemnification for damages resulting from the delay. However, if we or one of our representatives or agents are guilty of acting with intent or gross negligence, our liability in accordance with the legal specifications applying to gross negligence or culpable violation of essential conditions of the contract, in accordance with sentence 5 of this paragraph, is limited to the contractually foreseeable damage. Moreover, our obligation to pay compensation as a result of delay in delivery is limited to a maximum of 15 % of the agreed price (including sales tax) in accordance with sentence 5 of this paragraph. Additional claims from the customer are excluded. These limitations do not apply to liability arising from loss of life, physical injury or damage to health.
- (5) If we fail to deliver on time, the customer is entitled to write to us stipulating a suitable time limit for subsequent performance and informing us that he will refuse acceptance after expiry of this time. If this period of time granted for subsequent performance elapses without delivery being effected, the customer is entitled to issue a written statement of withdrawal from the contract or to demand compensation in place of the performance. Paragraph 4 applies accordingly in the case of claims for compensation in place of the performance. In cases where the period of time granted for subsequent performance expires without delivery being effected and where the customer has announced his intention to refuse acceptance, entitlement to delivery is excluded.
- (6) The customer is under obligation, when requested by us to do so, to state within a reasonable period of time whether, as a result of the delay, he intends to withdraw from the contract or whether he insists on delivery.
- (7) We are entitled to effect part deliveries and part services insofar as this is deemed reasonable for the customer.

5. Handover of the goods

The customer is under obligation to accept the goods delivered by us on the agreed date. The risk of accidental loss or accidental depreciation of the goods shall pass to the customer on delivery. The same is true if the object of sale is shipped from our factory to a location other than the headquarters of the customer by request of the customer and is handed over to the shipping agent, the carrier, or another person commissioned to perform shipping.

6. Liability for defects, other liabilities, limitation of claims

Our liability for significant defects in the delivery, subject to the customer having fulfilled his duty of inspection and notification as per § 377 of the German Commercial Code, is as follows:



- (1) We are entitled to effect compensation for significant defects in the object of sale by means of repair or replacement (supplementary performance), on the condition that we have been appropriately notified by the customer of the defects in question. The costs for supplementary performance will be borne by the customer in as far as these costs are higher due to the object of sale being shipped to a location other than the headquarters of the customer, unless this shipment is in accordance with the intended use.
- (2) If and when supplementary performance is rejected by us seriously and finally or due to unreasonably high costs, if two attempts to effect supplementary performance have failed or supplementary performance is impossible or cannot reasonably be expected, the customer will be entitled, at his choice, to reduce the purchase price (purchase price reduction) or to rescind the contract (rescission). Unless otherwise indicated (paragraph 3), further claims on the part of the customer, irrespective of the legal basis (in particular claims arising from failure to fulfil essential or ancillary contractual obligations, claims for reimbursement of costs with the exception of such in accordance with § 439 II of the Civil Code, unlawful acts or cases of liability in tort) are excluded. These limitations of liability are applicable above all for claims for damages not arising on the delivered item itself and for compensation for foregone profits. These also include claims not resulting from defectiveness.
- (3) Aforementioned exoneration from liability does not apply if the cause of damage stems from wrongful intent or gross negligence on our part or that of our representatives or agents, or at least if an essential cardinal obligation under the contract has been violated due to simple negligence on our part, thus jeopardising achievement of the objective of the contract. In such cases, we are liable under applicable law in the case of gross negligence or culpable violation of substantial contractual obligations, but our liability, in accordance with sentence 3 of this paragraph, is limited to the contractually foreseeable damage. These limitations do not apply to liability arising from loss of life, physical injury or damage to health or to liability under the German Product Liability Act.
- (4) The period of limitation for claims and rights in connection with defective delivery is 1 year from the passage of risk or, in the case of shipment via a shipping agent, carrier or another person commissioned to perform shipping, with handover of the consignment to these. The statutory period of limitation specified in sentence 1 also applies in the case of claims for damages not in connection with a defect. The statutory period of limitation in sentence 1 does not apply, however, in the case of § 438 Section 1 No. 1 of the German Civil Code (Legal Imperfections in Title for Real Estate), § 438 Section 1 No. 2 of the German Civil Code (Buildings, Objects for Buildings), § 479 Section 1 of the German Civil Code (Right of Recourse) or § 634a Section 1 No. 2 of the German Civil Code (Buildings or Works Whose Success Lies in the Performance of Planning or Monitoring Services). Here, the statutory period of limitation is 3 years.
- (5) The periods of limitation specified in paragraph 4 do not apply in the case of malicious intent, fraudulent concealment of defects, claims for damages arising from loss of life or liberty, physical injury or damage to health, in the case of liability under the German Product Liability Act, gross negligence of duty or violation of substantial contractual obligations.
- (6) Where our liability has been excluded or limited, this shall also apply to the personal liability of our employees, workers, representatives and agents.

7. Retention of title

- (1) We reserve title to all goods supplied until such time as the customer has paid in full all present and future claims arising from the business relationship.
- (2) If the customer violates the contract, in particular by delays in payment, we shall be entitled to recover the goods. The customer hereby gives his advance consent to recovery of the goods in such a case. Taking back the goods does not constitute withdrawal from the contract unless we have expressly declared this in writing. Costs incurred by us for recovery of the goods (in particular transport costs) will be borne by the customer. In addition, we are entitled to forbid the purchaser to resell or process the objects of sale delivered under retention of title and to revoke the collection authorisation (paragraph 5).
- (3) The customer is obliged to handle the objects of sale with due care.
- (4) The customer may neither pledge nor transfer or assign as security the objects of sale or claims arising therefrom. In the event of seizure of the goods or any other encroachments by third parties, the customer is under obligation to inform us in writing without delay, so that a suit can be filed in accordance with § 771 of the German Code of Civil Procedure. Any residual costs incurred by us arising from legal action under § 771 of the German Code of Civil Procedure despite our winning the case will be borne by the customer.
- (5) The customer is entitled to resell, process or combine the purchased goods in the ordinary course of business. However, with immediate effect, he assigns to us all claims to which he is entitled from resale, processing, combining of the purchased goods or on other legal grounds (in particular from the security or fraudulent activities), to the amount of the agreed final amount of the invoice, including VAT. The customer remains entitled to collect these claims even after assigning them to us, without prejudice to our right to collect the claim ourselves. However, we undertake to refrain from collecting the claim as long as the customer meets the payment obligations from the collected revenues, is not in arrears with payment or, in particular, has not filed an application to open insolvency proceedings or suspended payments. If this is the case, however, the customer is under obligation to provide us with details of assigned claims and the respective debtors as well as all details required to collect the claims, surrender to us the associated documents and inform the debtor (third party) of the assignment of the claim. We are entitled to revoke the collection authorisation in the case of contract violations (especially arrears in payment) by the customer.
- (6) The retention of title also extends to the full value of products ensuing from the processing, mixing or combining of goods supplied by us, whereby these processes are to be carried out in such a way that we are considered as the manufacturer. Should property rights of third parties exist in the case of processing, blending or combining their goods, we shall acquire joint ownership proportional to the objective values of the processed goods.
- (7) To secure our claims against him, the customer will also assign to us claims accruing to him against a third party from the combination of the goods supplied with real estate.
- (8) Securities to which we are entitled shall not be accounted for in as far as the value of our securities exceeds the nominal amount of the claims to be secured by 30%.

8. Flat-rate compensation for damages

If we are entitled to compensation for damages or as a result of depreciation in value from the customer, his representatives, or his agents—regardless of the legal basis—we are entitled to demand 20 % of the agreed sum without additional proof as compensation for damages or depreciation. We reserve the right to assert a higher claim for compensation or as a result of depreciation. The customer remains at liberty to furnish proof that no damage was incurred by us or that the damage amounts to significantly less than the flat rate of compensation.

9. Final provisions

- (1) All contractual relations between the parties to this contract shall be interpreted solely under the laws of the Federal Republic of Germany, any application of the UN Convention on Contracts for the International Sale of Goods (CISG) being expressly excluded.
- (2) Legal venue and place of fulfilment is the location of our business headquarters. However, we reserve the right to enforce our claims at any other appropriate legal venue.
- (3) If individual provisions of this contract are or become partly or wholly ineffective, the remaining provisions of this contract shall not be affected.
- (4) In as far as the contract or these General Terms and Conditions contain loopholes, the legal stipulations which the partners to the contract would have agreed upon in furtherance of the economic objectives of these General Terms and Conditions if they had been aware of the loopholes shall be deemed to apply.

Status: 09/2012



BEST GmbH
Modular clamping technology and automation
Raiffeisenstrasse 15
D – 70794 Filderstadt-Bonlanden
Tel. +49 (0)711 / 722579-70
Fax +49 (0)711 / 722579-99
info@best-spanntechnik.de
www.best-spanntechnik.de