

PRODUCT DATA SHEET

www.internationalgasdetectors.com

OLIVER IGD

Control Systems

Transmitters

Sensors

Accessories

T10-LPG-23R2W

TOC-10 Series Pre-Wired Gas Detector For LPG

TOC-10 Series gas detectors were designed by our clients after their in-field experiences using conventional domestic gas detectors. Our clients wanted IGD's reputation for quality and reliability in industrial markets but in a detector built for a domestic environment. Building on the deficiencies our clients encountered, TOC-10 sets the standard for this class of gas detector. TOC-10 finds applications in domestic gas safety but also in marine applications, commercial kitchens, schools, colleges and many more. All models have their own internal alarm sounders and clear visual alarm LED's. Models are then available depending on power source and required output interfaces. This model is fitted with a 3M mains lead allowing you to plug and go straight out of the box.



UK Design and Manufacture

Pre-Wired Plug and Go.

Front mounted detector has unique splash guard and dust filter

IP Rated seals fitted between the front and rear housing

Can be surface mounted using external mounting feet Possible to first fit during building work

Clear Visual Alarms

Sensor housing is sealed from the electronics housing blocking flammable gas

20mm Cable Entry Knockouts Centred to Allow Easy Drilling For Smaller

Loud audible Alarms

Standard 2 Gang Fixing Allowing Flush Mounting Using Standard Patress During Building



All Models have a 'link' function. Once linked if one TOC-10 goes into alarm then all linked units go into alarm



IGD
International Gas Detectors
CH₄ H₂S CO₂
NO NO₂ SO₂

OLIVER IGD
Triton House
Crosby Street
Stockport
SK2 6TS
England

Tel: +44 (0)161 483 1415
Fax: +44 (0) 161 484 2345
Email: sales@internationalgasdetectors.com
Website: www.internationalgasdetectors.com



FS646773
REF T10-LPG-23R2W-V1.07

PRODUCT DATA SHEET

www.internationalgasdetectors.com

OLIVER IGD

Control Systems

Transmitters

Sensors

Accessories

EC Declaration of Conformity

Issuers name and address:

Oliver IGD Limited of
Triton Hous,
Crosby Street,
Stockport,
SK2 6TS
England



Declares that the product listed as:

TOC-10-LPG-23R2W

Flammable point gas detector for use in 'safe' non-zoned areas only, stand alone operation.

Is in conformity with the provisions of the following European Directive(s) when installed, operated, serviced and maintained in accordance with the installation and operating instructions contained in the product documentation.

2004/108/EC EMC Directive

And that the standards and/or technical specifications referenced below have been applied or considered.

- EN 50194-1:2009 - Electrical apparatus for the detection of combustible gases in domestic premises. Test Methods and performance requirements.
- EN 50270:2015 - Electromagnetic compatibility. Electrical apparatus for the detection and measurement of combustible gases, toxic gases or Oxygen.
- EN 60335-1:2002 - Household and similar electrical appliances. Safety. General Requirements
- EN 60529 - Ingress Protection Rating
- EN 61000-6-2: 2005 - EMC Generic standards. Immunity for industrial environments
- EN 61000-6-4: 2007 - EMC Generic standards. Emission standard for industrial environments
- EN 61000-3-2/A2:2009 - EMC Limits. Limits for harmonic current emissions (equipment input current ≤ 16 A per phase)
- EN 61000-3-3: 2008 - EMC Limits. Limitation of voltage changes, voltage fluctuations and flicker in public low-voltage supply systems, for equipment with rated current ≤ 16 A per phase
- Technical File - T10-TF9 Technical construction File

Product Markings



TOC-10-LPG-23R2W *SI*-serial number

Oliver IGD Limited Operate and Independently assessed ATEX/IECEX QAN.

Oliver IGD Limited operate an independently assessed ISO9001:2008 Quality Management System.

Testing Agency:

Quality Assurance Certificate Number
ExVeritas 16PQAN0014

Quality Management Certificate Number
FS 646773

TUV - SUD
Octagon House
Concorde Way
PO 15 5RL
Fareham



Mehr Sicherheit.
Mehr Wert.

Quality Assurance Notification Number:
2585

ExVeritas,
Units 16-18,
Abenbury Way,
Wrexham Industrial Estate,
Wrexham, UK, LL13 9UZ

BSI Assurance UK LTD,
Chiswick High Road,
London
W4 4AL
UK

TUV Certificates and reports can be checked on-line at https://www.tuev-sued.de/industry_and_consumer_products/certificates

Issued on: 10 Feb 2016

At Oliver IGD Limited, Stockport, SK2 6TS, United Kingdom

Signature:

Declaration of Conformity in accordance with EN ISO/IEC 17050-1:2010

Name

Andrew J Collier M.I.O.D

Position:

Managing Director

Date: 10 Feb 2016

Declaration Ref: TOC-10-DEC-2



International Gas Detectors

CH₄ H₂S CO₂
NO₂ NO₂ SO₂



Triton House
Crosby Street
Stockport
SK2 6TS
England

Tel: +44 (0)161 483 1415

Fax: +44 (0) 161 484 2345

Email: sales@internationalgasdetectors.com

Website: www.internationalgasdetectors.com



FS646773

REF T10-LPG-23R2W-V1.07

PRODUCT DATA SHEET

www.internationalgasdetectors.com

OLIVER IGD

Control Systems

Transmitters

Sensors

Accessories

Please Note This Model is Supplied Pre-wired with a Mains Lead and so Does Not Require Installation by a Qualified Person. The Following Interfaces are Also Included

Installation requirements

Terminal Functions

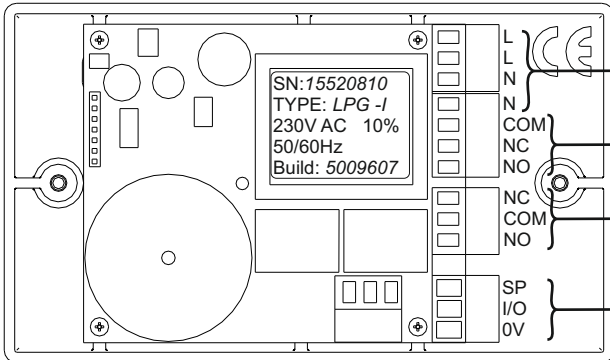

Power Supply With Auxiliary Output Terminals
 Alarm Level 1 Relay Terminals Active at Nominally 10% LEL
 Alarm Level 2 Relay Terminals Active at Nominally 25% LEL
 Data interconnect between Toc-10 units for linked operation

! Warning !

This unit is supplied pre-wired with a 3M mains lead. The additional interfaces listed here may require installation by a competent person. The unit is supplied pre-calibrated but should be checked regularly, at least monthly using the test feature. Clean only with a damp cloth do not use any cleaning products



Do not tamper with this equipment to do so may risk electric shock or incorrect operation

Typical Operation

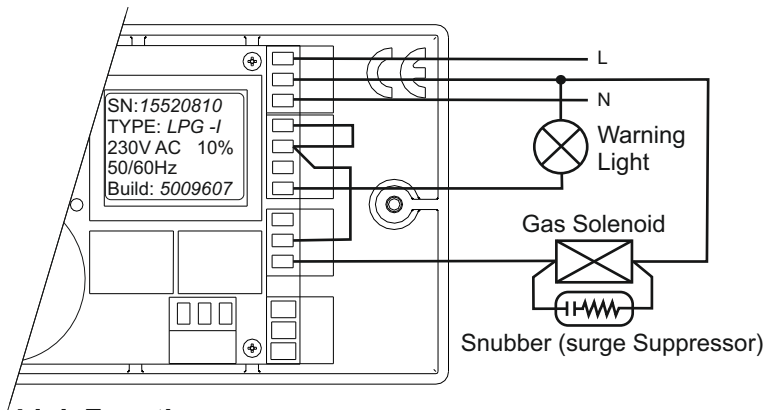

Example shows a Toc-10 © Wired to a gas supply solenoid valve and warning light. The warning light is active in this example when the first alarm level is reached (10%) and the gas solenoid is de-activated when the second alarm level is reached (25%). Note in this example a surge suppressor is fitted to the gas solenoid to extend the life of the relay. For DC solenoids a diode could be fitted. Any such installation must comply with the national regulations in force in the country EN1775 refers

Link Function

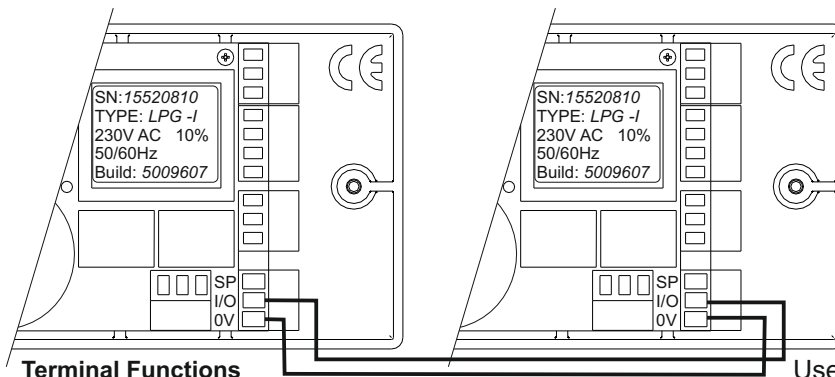

Up to 8 Toc-10 © units can be linked together using the I/O and 0V terminals. When linked the Toc-10 © units have common alarm and common reset function.

Use minimum 0.75mm² Cable

Other Models Available

LPG Models

T10-LPG-12RP	Marine 12V DC Version with 2 Alarm Relays
T10-LPG-23	Basic LPG Version No Relay Outputs
T10-LPG-23R	Single Relay Version
T10-LPG-23R2W	Fitted With 3M UK Mains Lead and 2 Alarm Relays

Methane (Natural Gas) Models

T10-CH4-23	Basic CH4 Version No Relay Outputs
T10-CH4-23R	Single Relay Version
T10-CH4-23RP	Full Version With 2 Alarm Relays
T10-CH4-23R2W	Fitted With 2M UK Mains Lead and 2 Alarm Relays

IGD

International Gas Detectors

CH₄ H₂S CO₂
 NO₂ SO₂ NO₂ SO

OLIVER IGD

Triton House
 Crosby Street
 Stockport
 SK2 6TS
 England

Tel: +44 (0)161 483 1415

Fax: +44 (0) 161 484 2345

Email: sales@internationalgasdetectors.com

Website: www.internationalgasdetectors.com



FS646773

REF T10-LPG-23R2W-V1.07

PRODUCT DATA SHEET

www.internationalgasdetectors.com

OLIVER IGD

Control Systems

Transmitters

Sensors

Accessories

Alarm Indications

	Relay 1	Relay 2	Sounder	Power LED	Fault LED	Alarm LED
FOLLOW EMERGENCY ACTIONS	Alarm 1 10% LEL	✓	✓	☀		☀
	Alarm 2 25% LEL	✓	✓	☀		☀
Normal				☀		
Fault				☀	☀	
				No Pwr LED	☀	

CALL FOR SERVICE

Physical Details

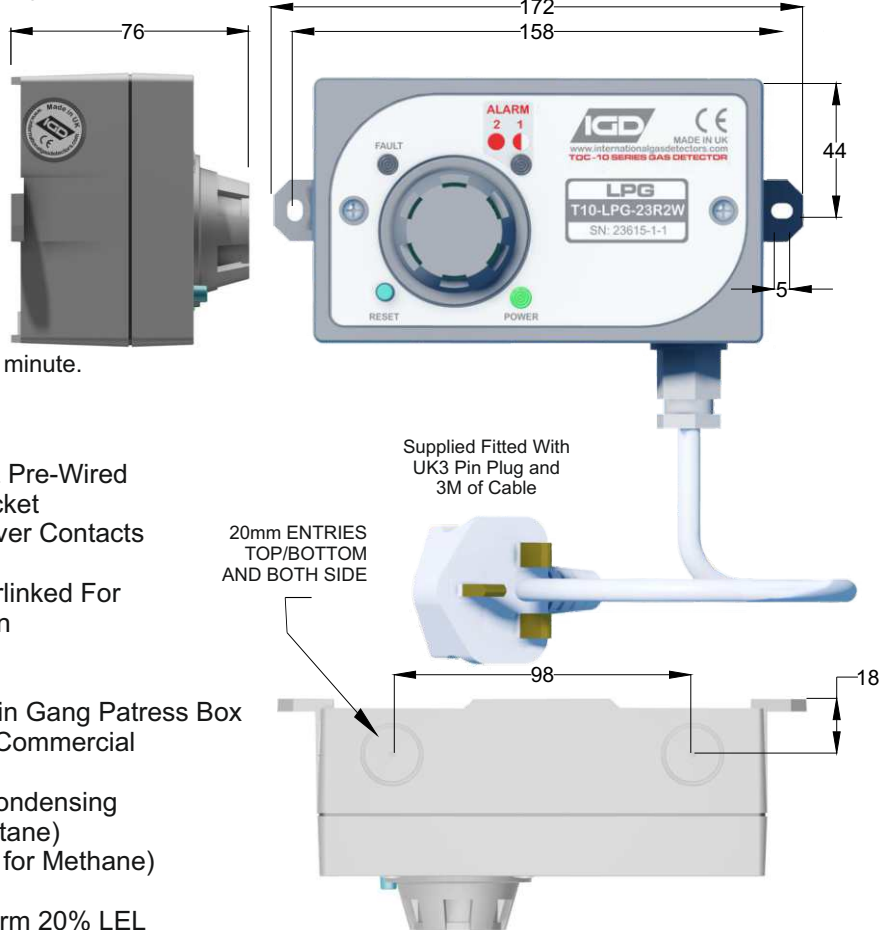

Note that the power LED will flash during warm up for 1 minute.

Standard Specifications

Supply Voltage	230V AC 50/60Hz Pre-Wired Uk 3 Pin Plug Socket
Control Relay	2 Relay Changeover Contacts 4 A @ 230V AC
Interfacing	Up to 6 Units Interlinked For Network Operation
Protection Category	IP55
Insulation	Class II
Installation	Wall Mounting Twin Gang Patress Box
Environment of Application	Residential/Light Commercial
Operating Temperature	0 - 55 Deg C
Operating Humidity	0-90% RH Non Condensing
Types of Gas Detected	LPG (Propane/Butane) (options available for Methane)
Alarm Level	Warning 10%, Alarm 20% LEL
Sensor Warm up Time	Typically 1 Minute
Reference Standards	LVD EN 60335-1 EMC EN 50270 Gas Alarms EN 50194 Ingress Protection EN 60529 BSI tested to BSI1363
Plug Lock Tested to:	



Pre-Wired TOC-10 models are supplied with plug-locks to prevent unintended removal from the mains supply. Tamper-proof stickers are also provided to cover the switch slot after installation.

This does not require an electrician to install. Plug Lock aids compliance in schools to O.F.S.T.E.D rule 6.9

General Information

The TOC-10 © is pre-calibrated for its indicated target gas, usually LPG or Methane. The TOC-10 © will respond to any flammable gas to a greater or lesser degree. The following list indicates typical materials that may be commonly present which the unit may respond to in operation:

Aerosol Propellants (Butane)
Paint Solvents (VOC's)
Hot Cooking Oils
Nail Varnish
Solvent Based Adhesives (VOC's)

Some commonly occurring substances may cause long term detector damage, typically:

Silicones (furniture polishes)
Hair sprays (Silicones, VOC's etc)
Chlorinated Cleaning Agents



International Gas Detectors

CH₄ H₂S CO₂
NO₂ SO₂ NO₂ SO



Triton House
Crosby Street
Stockport
SK2 6TS
England

Tel: +44 (0)161 483 1415

Fax: +44 (0) 161 484 2345

Email: sales@internationalgasdetectors.com

Website: www.internationalgasdetectors.com



FS646773

REF T10-LPG-23R2W-V1.07