



TOC-750 SERIES 2-WIRE ANNUNCIATORS

Operation and Maintenance

V 1.30

OLIVER IGD

Triton House
Crosby Street
Stockport
SK2 6SH
England

Tel: +44 (0)161 483 1415
Fax: +44 (0) 161 484 2345
Email: sales@internationalgasdetectors.co.uk
Website: www.internationalgasdetectors.co.uk



FS646773
REF: 750M-2

Index

Typical Models Covered By This Manual	1
Physical and Mounting Details	2
Module PCB Features	3
Connection Possibilities	4
Interconnecting Modules on a Data Highway	5
Relay Output	6
Solid State Output	7
Digital Input	8
4-20mA Inputs	9
Pellistor (Catalytic) Flammable Gas Detector Interface	10
Module Indications	11
Assigning Addresses	12
Local Sensor Zero and Calibration Required Equipment	13
Detector Zero Sequence	14
Detector Calibration Sequence	15
Reset to Defaults	16
CE Declaration	17

Important Notes

Gas detection systems must be correctly specified, installed and maintained in order to be effective. Anyone undertaking elements of this work should have access to the necessary equipment and be able to demonstrate competence. This will usually mean having passed a training competency course. International Gas Detectors run training courses for safety survey, specification, installation and service aspects of hazardous gas detection systems. In addition IGD can supply test equipment and calibration gases necessary to undertake this work.

Please note the following points

1. A zero grade gas usually instrument air or Nitrogen and a suitable calibration gas mixture is required.
2. The correct gas adaptors must be used to apply gases to detectors when zeroing and calibrating. Incorrect application of gases can affect calibration results
3. Use equipment and gases traceable to a national standard. Any calibration will only be as good as the equipment and materials used.
4. IGD supply fixed flow regulators for use with IGD calibration gas bottles which supplies gas at 0.5L/Min
5. **Refer to *2-Wire Gas Detection Systems Installers Guide* before installation.**

Typical Models Covered By This Manual

TOC-750 Series Hazardous Gas detectors can be supplied in a number of formats. Some typical models are indicated in the diagram below. All 750 Series detectors and annunciators use a common 'module' PCB as indicated below to interface between the detector or interface and the control panel using IGD's Sentinel+ 2-Wire protocol. A single 2-Wire 'Highway' can support up to 32 devices interfaced using the 'module' PCB. Highways can be up to 1000M long depending on cable size and detector types.

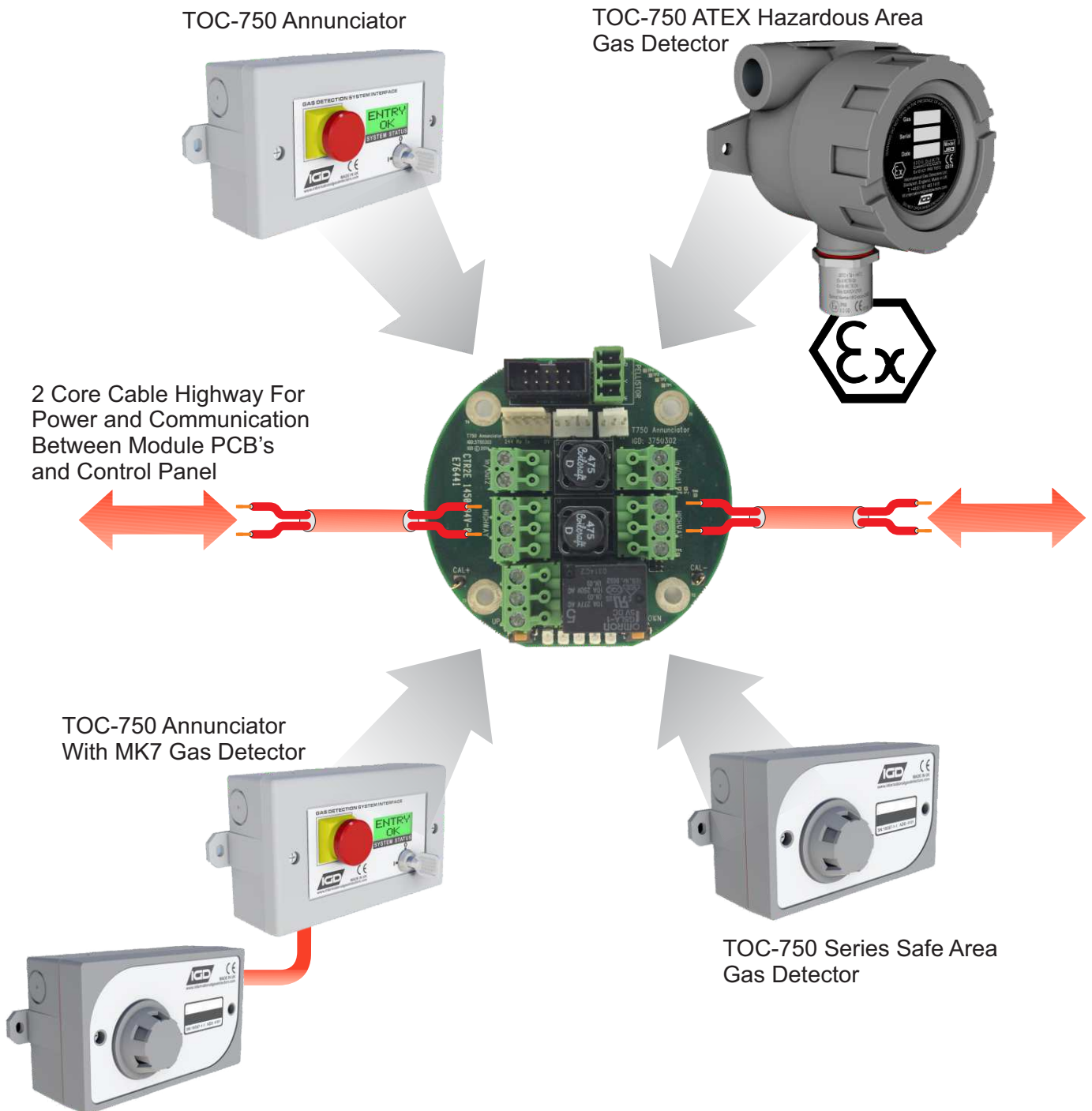

Mounting Details and Dimensions ATEX Versions

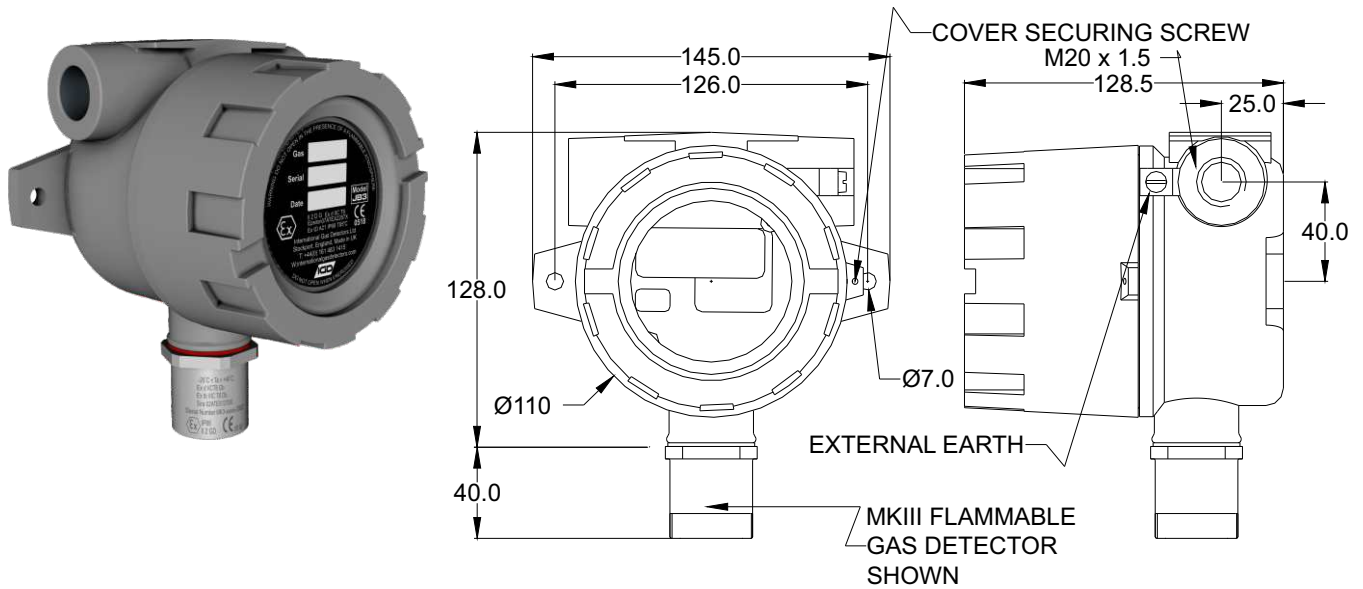

The ATEX version uses IGD's JB3 series ATEX EXD terminal enclosure. Please note that cable glanding and sealing must conform to ATEX requirements which is more fully described in the ATEX JB3 manual

Mounting Details and Dimensions Safe Area Versions

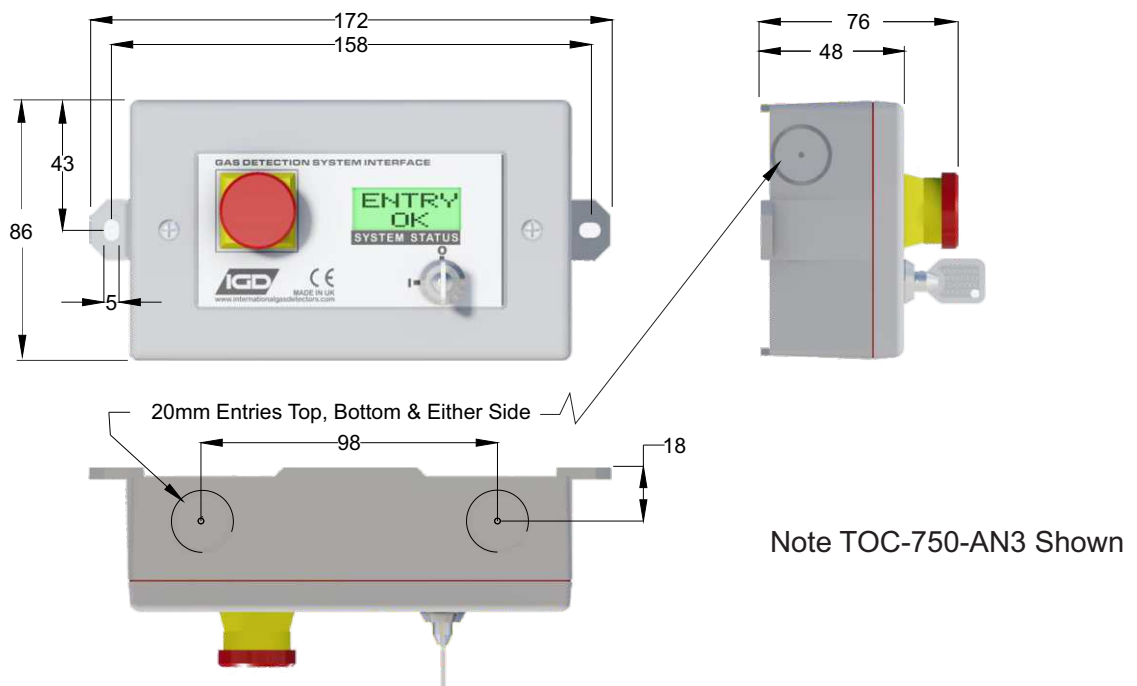

Module PCB Features

The following diagram indicates features available on the TOC-750 'module' PCB. Please note that failure to observe and make correct connections or exceed ratings may result in damage to the PCB.



Ribbon Cable Connection For TOC-750 Annunciator Display and Options

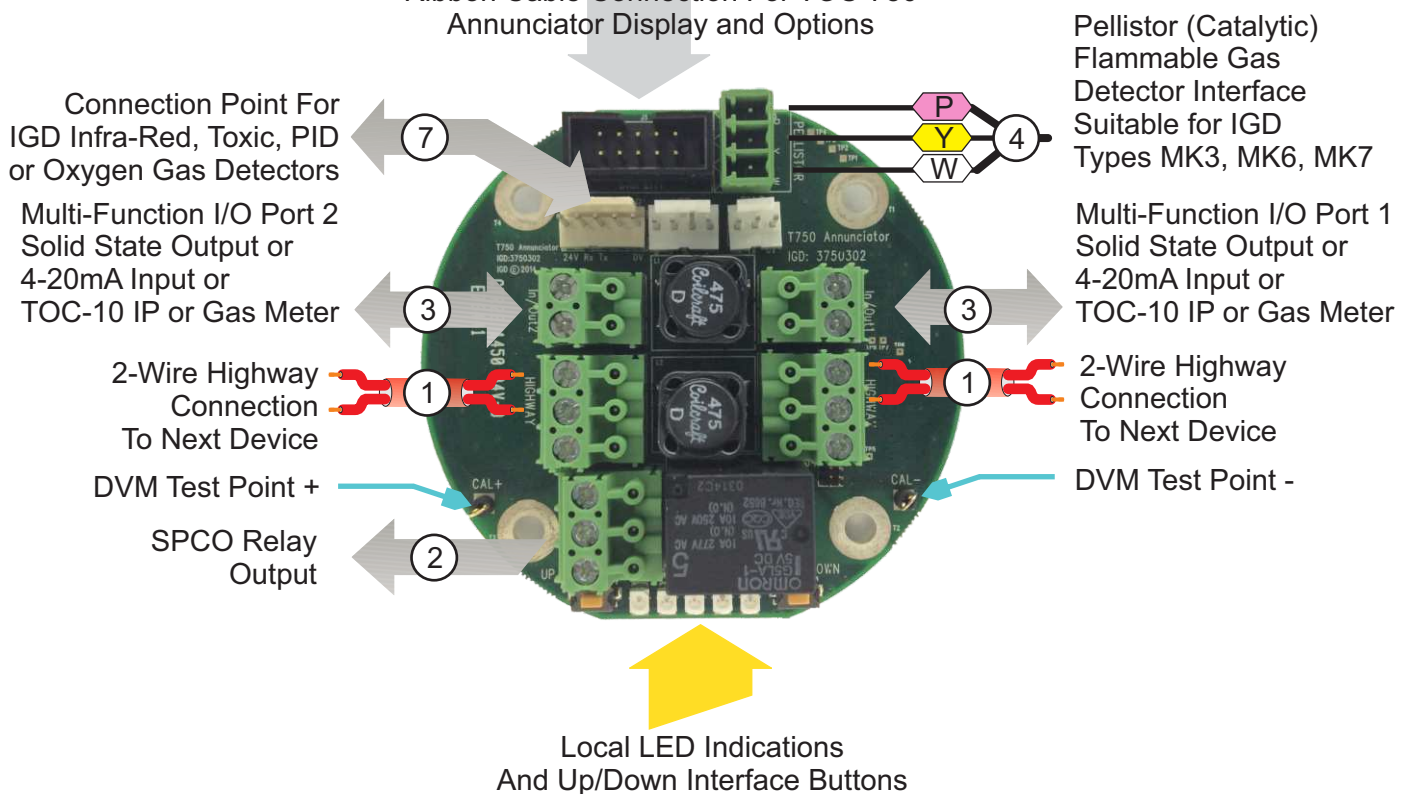

Pellistor (Catalytic) Flammable Gas Detector Interface Suitable for IGD Types MK3, MK6, MK7

Multi-Function I/O Port 1 Solid State Output or 4-20mA Input or TOC-10 IP or Gas Meter

2-Wire Highway Connection To Next Device

DVM Test Point -

Module PCB Basic Interface Specifications

Housing	TOC-750 Series ABS or Copper Free Aluminium For ATEX Versions
Sealing	IP65 (using suitable glandings) for TOC-750, IP68 for ATEX Versions
Environment	0 -95% RH Non Condensing
Temperature	0-55 Deg C
Voltage	12-28V DC
1 Communication	IGD 2-Wire Highway Operating IGD Sentinel+ Protocol Using 2 Core UN-Screened Cable Not Polarity Dependant
2 Relay	5A Non Inductive Loads 230V AC
3 Digital Output	24V DC 100mA Combined For Both Outputs Typically for LED Beacon Sounders
Digital Input	Suitable for use with TOC-10 Link Function
4 Pellistor Port	Option to Interface to MK3, MK6 or MK7 Pellistors
5 Sounder	85dB (Option for TOC-750 Annunciators)
6 Display	2 x 8 Programmable LCD with RGB Backlight (Option for TOC-750 Annunciators)
7 Comm Port	Supports IGD Infra-Red, PID, Toxic and Oxygen Gas Detectors

Connection Possibilities

The 750 Series Module PCB Operates as an Interface 'Hub' on the Addressable 2-Wire Highway. The Diagram Below Shows a Typical Set of Connection Possibilities

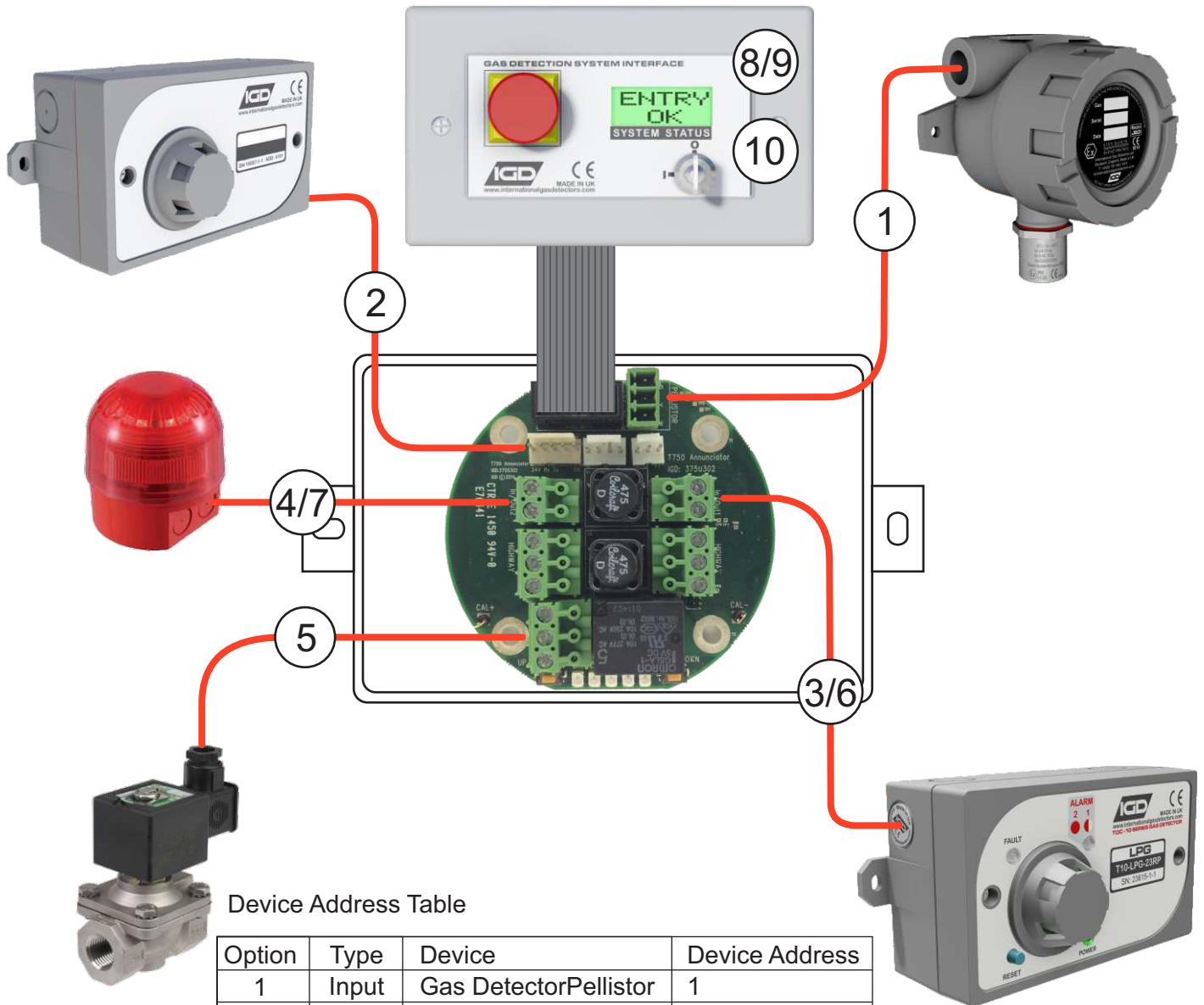

Device Address Table

Option	Type	Device	Device Address
1	Input	Gas Detector Pellistor	1
2	Input	Toxic Gas Detector	2
3	Input	TOC-10	3
4	Input	4-20mA	4
5	Input	E-Stop	5
6	Output	Solid State Output	102
7	Output	Solid State Output	103
8	Output	Relay & OP1	101
9	Input	Key Switch	6
10	Output	Sounder	104

I/O Port 2
Either Input
or Output

I/O Port 1
Either Input
or Output

Note that one 2-Wire addressable highway running Sentinel+ protocol can support up to 32 modules. Each module can have up to 8 connected devices. IGD Configuration software is used to configure the module PCB to switch devices on and off and set addresses (see Tocsin 650/750 Manual). If the connected devices have already been configured then the base address can be set from which all other module addresses will sequentially follow. This is described later in this manual. Device addresses indicated in the table are typical but can be individually set.

Interconnecting Modules On A Data Highway

Tocsin 750 Series Annunciator Modules are interconnected as follows using two core cable. The system is designed to operate using unscreened cable. In some circumstances, for instance in ATEX Zone 1 areas a protective armour may be desirable to provide mechanical protection. The system provides both power and digital communication over the single pair of wires. The system is also polarity insensitive although best practice would be to connect L1 to L1 to L1 and L2 to L2 to L2 etc for continuity. It is necessary to fit an IGD terminator at the last device as indicated for operation of the system.

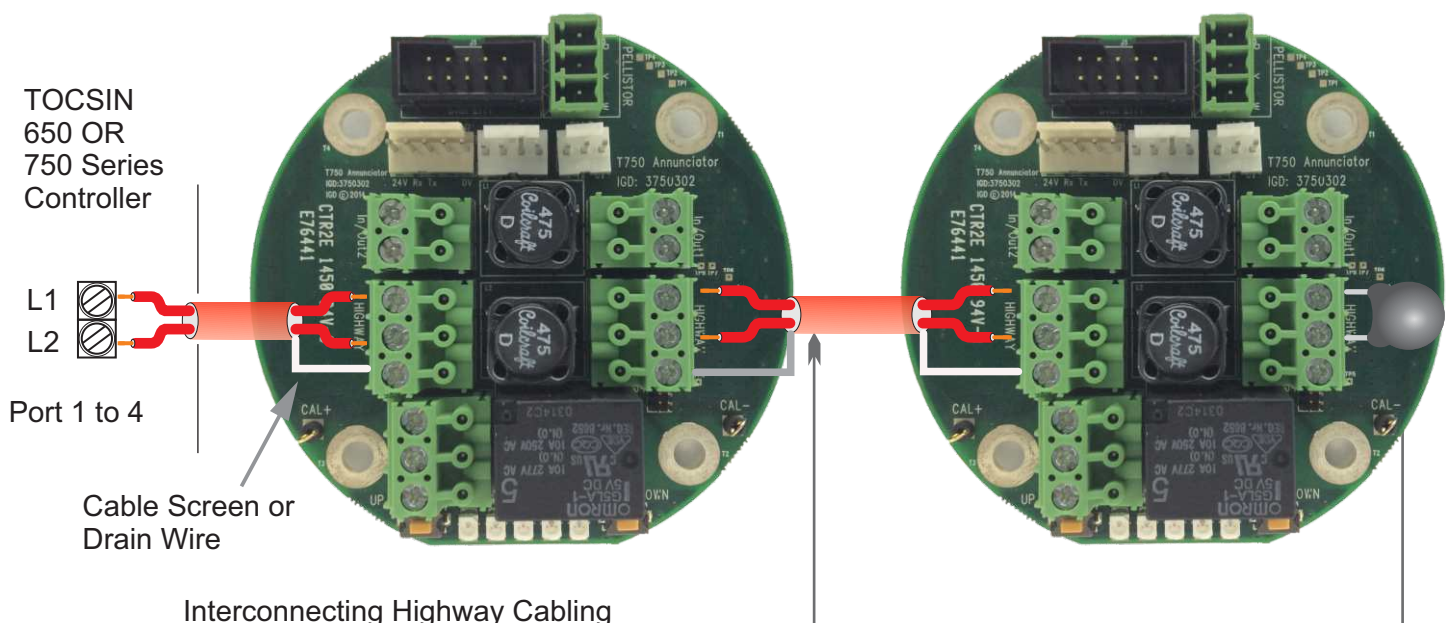

Interconnecting Highway Cabling
For 2-Wire Addressable Systems:

For Safe Area Detectors Use 2 Core
Unscreened Cable 1.0 to 2.5mmSQ
Cable Depending on Distance.

For ATEX Units Typically Use 2 Core
SWA Cable 1.0 to 2.5mmSQ
Depending on Distance

See Cable Calculator for Cable Core
Size vs Distance VS Number of
Devices

End of Line Terminators Must
be Fitted at the Last Module in
Line as Indicated Across the
L1 and L2 Terminals.

Terminators are Shipped With
All Control Panels.
Spare Terminators Can be
Ordered Using Part Number :
TOC-750-TRM.

Failure to Fit Terminators Will
Prevent System Operation

Relay Output

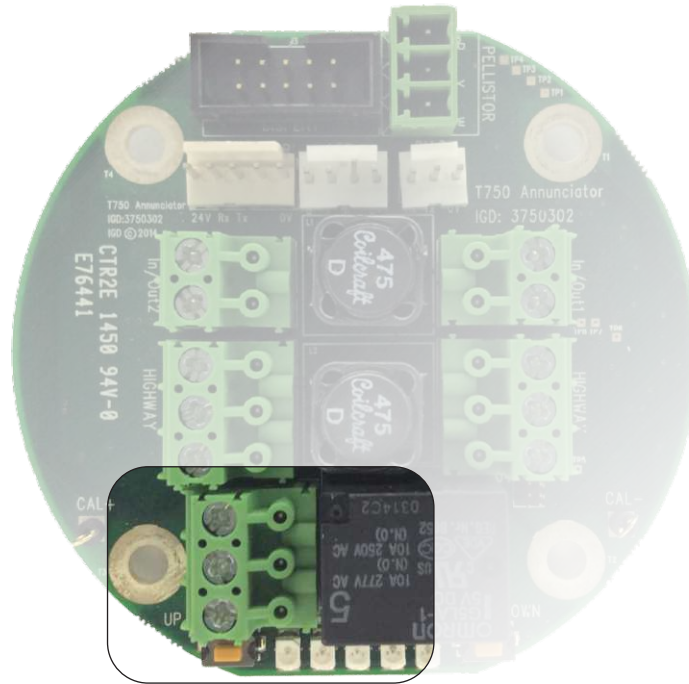

The Annunciator relay output can be used as an alarm interface to external systems, run additional audio visual alarms or directly control other devices. Typical applications could be gas solenoid valves, boiler shut down interfaces or similar. When switching external loads it is important to consider the nature of the load being switched. For inductive loads suitable protection from induced back EMF must be fitted. Many modern devices conforming to the European EMC Directive may already have devices fitted as part of their design to limit in-rush currents and back EMF. Where these are not fitted the following two diagrams provide guidance. Failure to observe this may result in damage to the Annunciator.

Example fit protection diodes when switching external DC loads. 1N4004 Diodes are provided with each module.

For Additional Diode Packs
IGD PN: TOC-750-DIO

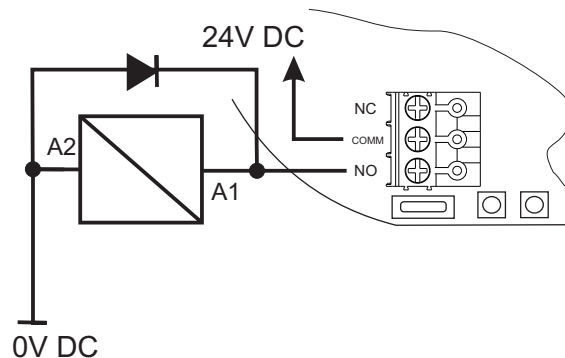

FOR DC LOADS
DO NOT EXCEED
30V DC 5A

Example fit protection suppressors when switching external AC loads typical device provided with each module 47R 1uF

For Additional Units
IGD PN: TOC-750-SNB

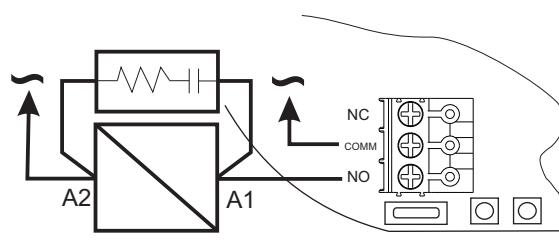

FOR DC LOADS
DO NOT EXCEED
250V AC 5A

Solid State Output

Each Detector Node has 2 multi-function input - output ports. These can be configured independently as either 4-20mA inputs, Digital Inputs or solid state outputs. The solid state outputs are typically intended to switch small loads such as LED beacon sounder modules or small signal interface relays as indicated below. As standard Detector Nodes Ship with I/O Port 1 and 2 setup as Solid state outputs, negative switching

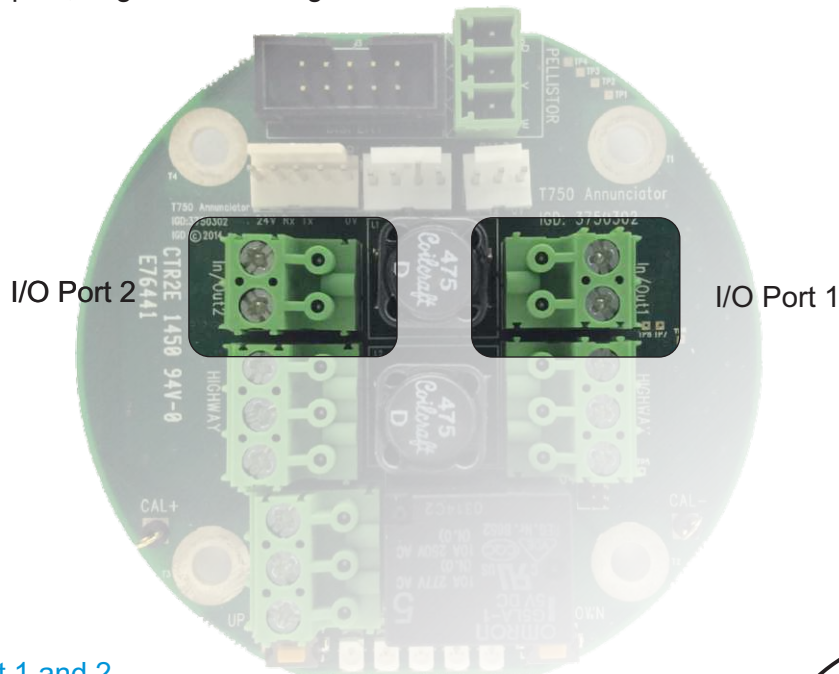

Wiring to I/O Port 1 and 2

The Solid State Outputs Can be used to Switch LED Beacon Sounders if Required.

It is recommended to use IGD LED Beacon Sounders Part Number 5083101 Connections Shown are for 5083101 and shown one output switching the beacon and one port switching the sounder. This allows the controller to mute the sounder on accepting an alarm.

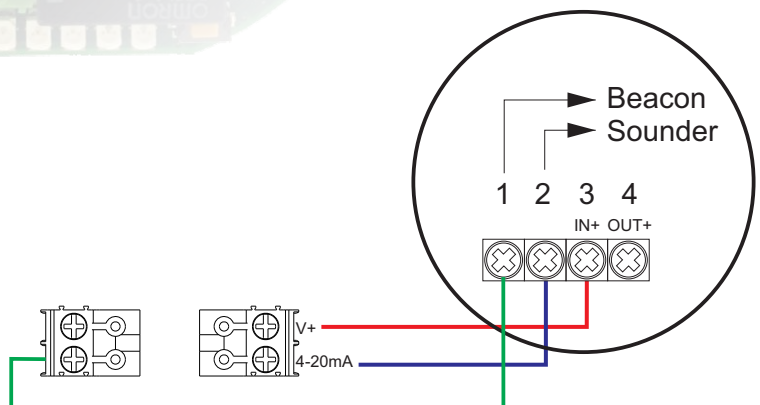

When using Other Manufacturers Devices do Not Exceed 100mA @ 24V DC Total combined Load for Port 1 and Port 2

When Switching Small interface relays ensure protection diodes are fitted as indicated, these are supplied with the module. Failure to do so can result in damage to the output. Ensure relay coil is rated at 24V DC and Max 100mA or Min 240 Ohms. Do not exceed 100mA Load Port 1 and Port 2

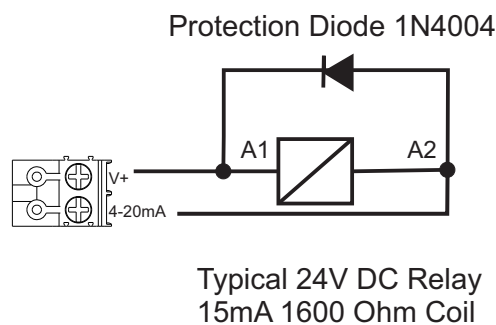

Digital Input

Each Detector Node has 2 multi-function input - output ports. These can be configured independently as either 4-20mA inputs or solid state outputs. The digital inputs are typically intended to totalise pulse counts, mainly from gas meters, or use for slam switch/ E-Stop applications

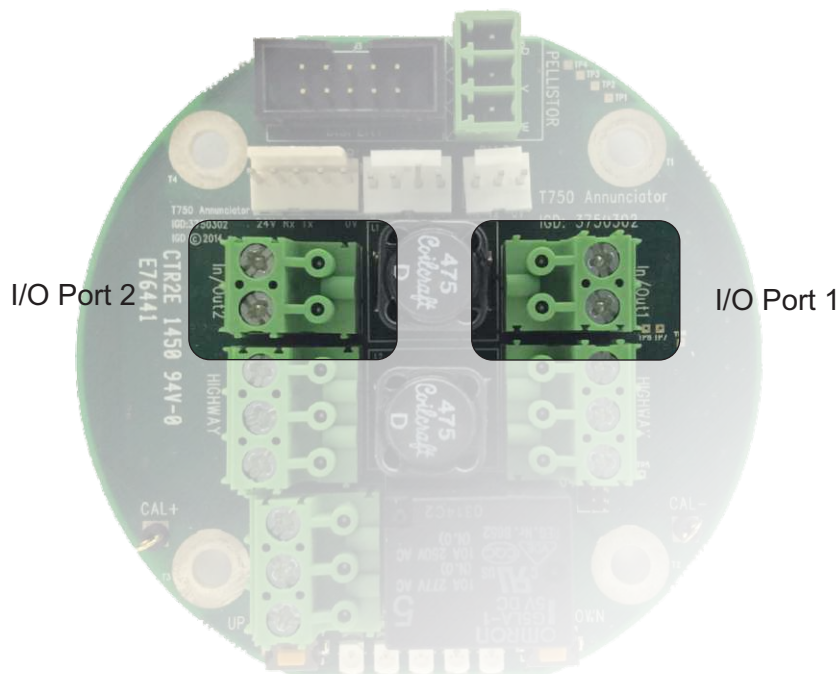

Wiring to I/O Port 1 and 2

The Solid State Input Will Accept up to a 0.2 Hz Pulse Train Input From a Gas Meter or Similar Device. Typically 0.2Hz equates to 7.2M3/Hr @ 1 Pulse/0.01M3

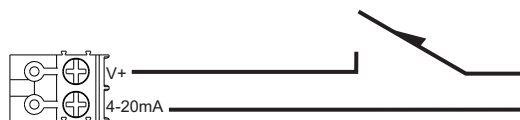

If You Are Wiring Digital Inputs (24V) Option Then You Need to Include a 560 Ohm Resistor to Limit Current Around the Circuit



If You Are Wiring Digital Inputs (0V) Option Allows Logic inputs from External Devices. Anything Less Than 1.5V DC is Treated as Off Anything Greater is On

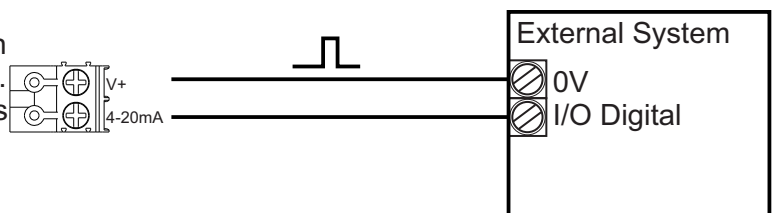

Solid State Input From TOC-10 Gas Detector

The Solid State Input can be used to interface to IGD TOC-10 Series Flammable Gas Detectors. Wire as Indicated and the Input Will Read the Two Alarm Levels From the TOC-10. This will display on an Addressable Controller in the Same Manner as Any Other Gas Detector. Up to 6 TOC-10 Detectors can be Daisy Chained to the Input

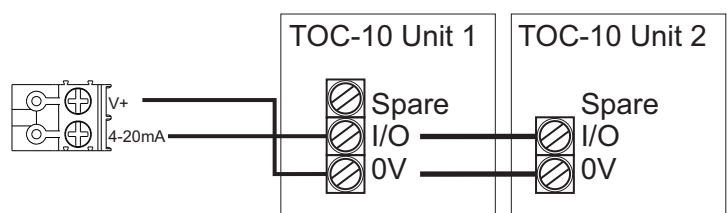

4-20 mA Inputs

Each Detector Node has 2 multi-function input - output ports. These can be configured independently as either 4-20mA inputs or solid state outputs. When used as 4-20mA inputs any standard 4-20mA loop powered can be read in as an analogue signal. Using the setup routine the signal can be scaled and then read back addressably onto the system controller.

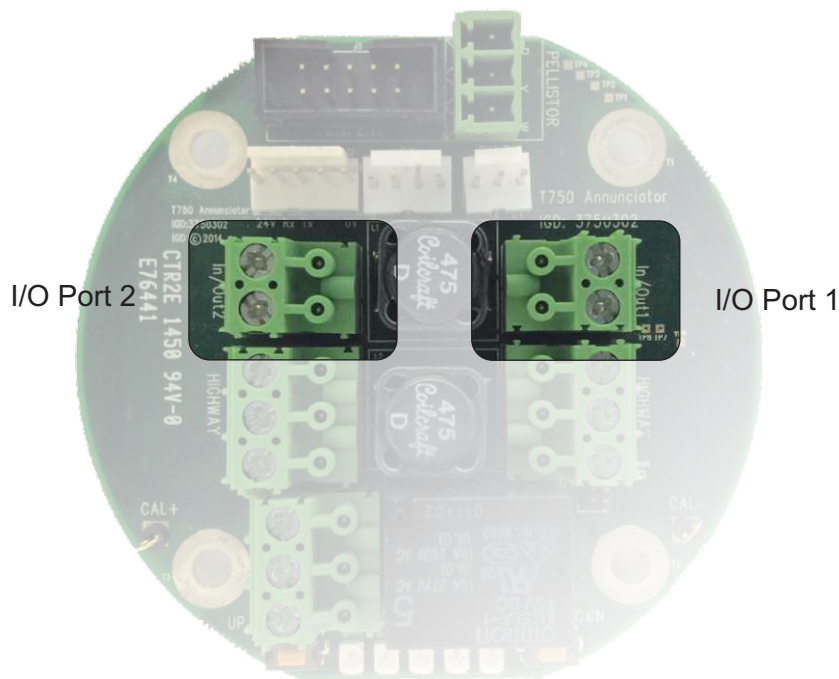

Wiring to I/O Port 1 and 2

a) For a 2 Wire Loop Powered Device (4-20MA 24V Option)

The Input Sources a 24V DC supply then sinks the signal current on the module PCB across a 122 Ohm resistor on the PCB

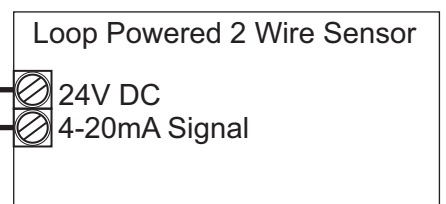
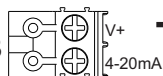

b) For a 2 Wire 4-20mA Device Externally Powered Device (4-20MA 0V Option)

24V DC Power is supplied from an external source then sinks the signal current on the module PCB across a 100 Ohm resistor on the PCB. Note the 0V DC Common Connection.

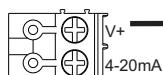

External Power

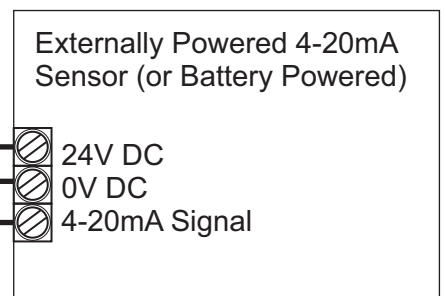

Pellistor (Catalytic) Flammable Gas Detector Interface

The module PCB is equipped with a Pellistor or Catalytic flammable gas detector interface. This supports all IGD manufactured pellistors as indicated below. Note that the correct pellistor option must be selected in the setup software routine for the pellistor to operate correctly.

The Pellistor can be mounted remotely from the PCB. When doing so do not exceed the indicated cable length.

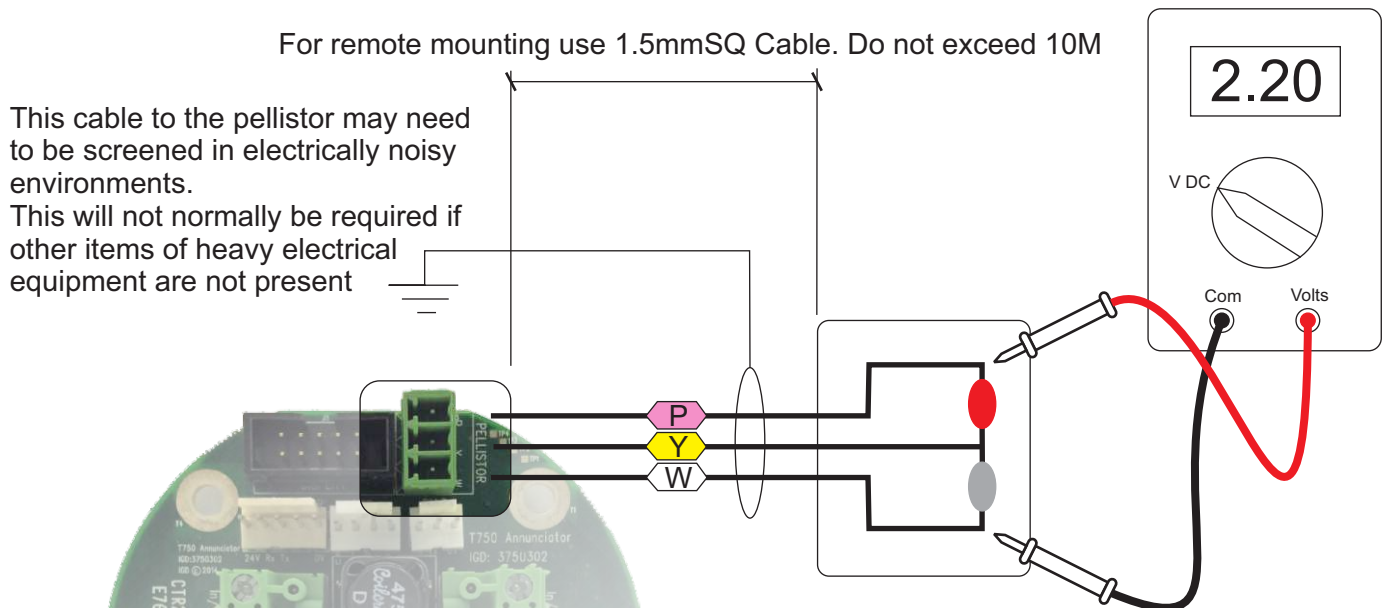

IGD Pellistors Supported

Type		Head Current	Head Volts
MK3	ATEX EXD IIC T6	360mA	2.2V
MK6	Safe Area	170mA	2.5V
MK7	Safe Area	170mA	2.5V

Note: The Pellistor 'Type' is selected using IGD service tool app or by using the setup routine in the TOC-750 Software. Once selected this automatically sets the head supply voltage.

In operation and with zero air applied correctly to the detector the 'balance' between the two detector 'beads' as measured P-Y and Y-W should not show a difference of more than 70mV. If the difference is larger than this then it could be an indication of aging or damage and the detector should be replaced.

Module Indications

Each module has two push buttons, labelled up and down and five LED's. In operation the LEDs and buttons work together to allow local calibration, change or reading of the base address or connected status as follows:

Connected Status

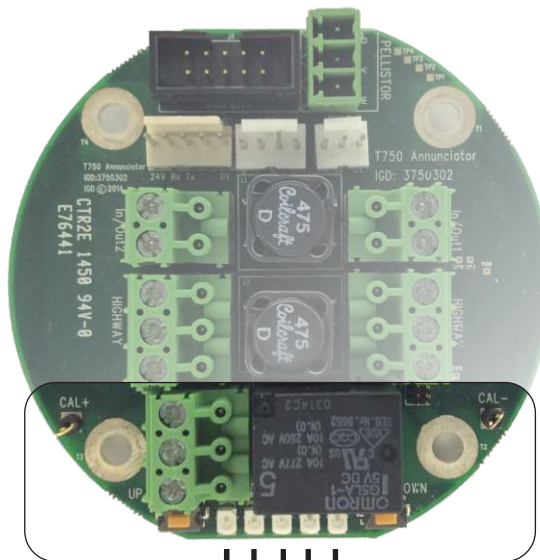

- LED 1
Lit Green if pellistor option activated
Flashing green see table
- LED 2
Lit Green if IR-PID-Toxic option activated
Flashing green see table
- LED 3
Lit Green if I/O Port 1 option activated
Flashing green see table
- LED 4
Lit Green if I/O Port 2 option activated
Flashing green see table
- LED 5
Lit Green if Relay option activated
Flashing green see table

Note the LED flash rate is used to indicate as follows:

LED Flash Rate	Indicates
ON no Flash	Option Enabled and Powered But No Communication
1 per Second	Option Enabled Powered and Communication All OK
5 per Second	Line Voltage Low only LED 1 then LED 5
1 per 10 Seconds	Option Has a Fault Condition

Note: IGD App is used to configure the module PCB to switch devices on and off and set addresses (see Tocsin 650/750 Manual).

The TOC-750 Module PCB is an Addressable Device and Comes Equipped With a Simple Interface to Allow the Base Address to be Set. To Set The Set Address,

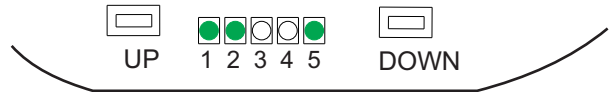

Press and hold the Down button for >2s

Release Button the Light Pattern Will Now Indicate the set Address as Shown in the Table Below.

With the Set Address Lit, the UP and DOWN buttons can now be used to alter the address if required

With the Required Address lit, Press and Hold the DOWN Button Until the LED's go out. Release the DOWN button and the new Base Address is Now Set.

Note That with the base address set the LED's revert to showing what options are active and which of those options are communicating, see previous section on 'Module Indications'.

1	2	3	4	5	
					00
☀					01
	☀				02
☀	☀				03
		☀			04
☀		☀			05
	☀	☀			06
☀	☀	☀			07
			☀		08
☀			☀		09
	☀		☀		10
☀	☀		☀		11
		☀	☀		12
☀		☀	☀		13
	☀	☀	☀		14
☀	☀	☀	☀		15
				☀	16
☀				☀	17
	☀			☀	18
☀	☀			☀	19
		☀		☀	20
☀		☀		☀	21
	☀	☀		☀	22
☀	☀	☀		☀	23
			☀	☀	24
☀			☀	☀	25
	☀		☀	☀	26
☀	☀		☀	☀	27
		☀	☀	☀	28
☀		☀	☀	☀	29
	☀	☀	☀	☀	30
☀	☀	☀	☀	☀	31

Note when editing if an Annunciator Display is fitted the base address display will also update

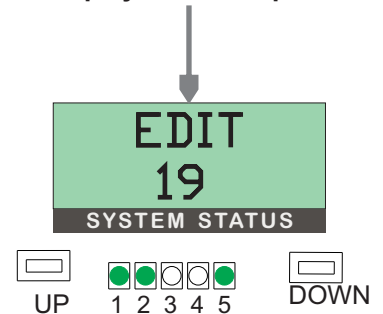

Setting the base address using the button interface sets the address for all other active options on the module as follows:

For a Base Address Set of 01:

- Pellistor Input = Base Address = 01
- 02 = IR/PID/Toxic or Oxygen Sensor
- 03 = Digital or analogue Input 1
- 04 = Digital or analogue input 2
- 05 = E-Stop
- 06 = Key Switch

- 101 = Relay & Sounder
- 102 = Digital Output 1
- 103 = Digital Output 2
- 104 = Display Sounder

Anything turned off is ignored. Addresses are allocated in the following sequence.

NOTE: WHEN SETTING ADDRESSES YOU CANNOT HAVE TWO DEVICE ADDRESSES SET THE SAME ON THE SAME ADDRESSABLE HIGHWAY or DEVICE.

Local Sensor Zero and Calibration

Each module has a simple interface which enables local calibration using a suitable multi-meter set to read DC voltage to 2 decimal places as follows

Connections and Required Equipment

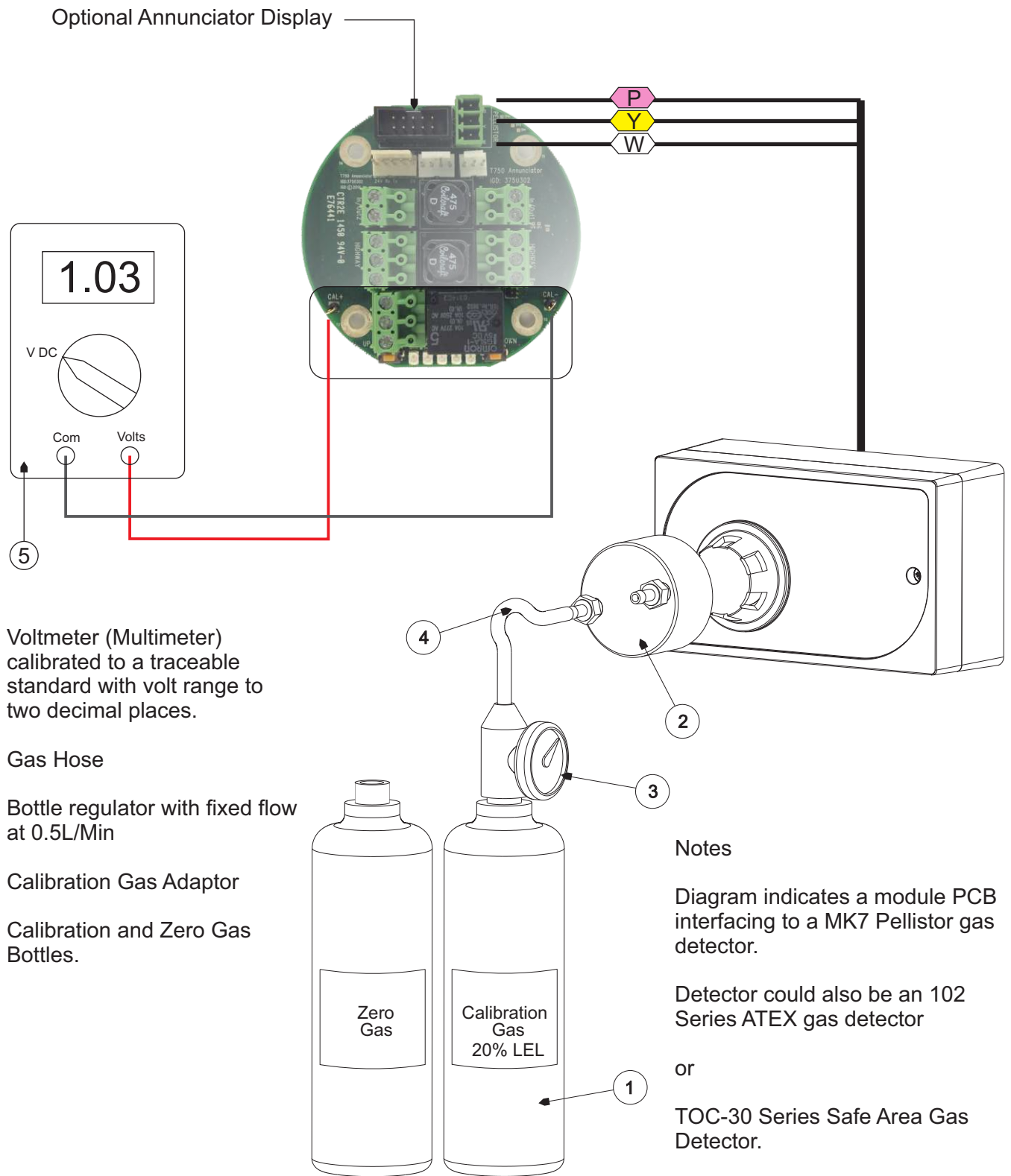

- ⑤ Voltmeter (Multimeter) calibrated to a traceable standard with volt range to two decimal places.
- ④ Gas Hose
- ③ Bottle regulator with fixed flow at 0.5L/Min
- ② Calibration Gas Adaptor
- ① Calibration and Zero Gas Bottles.

Detector Zero Sequence

The module PCB has four inputs which can be enabled and calibrated locally using the equipment set previously described. When the module PCB is powered and as described in the indications section, the LED's will indicate which options are enabled .

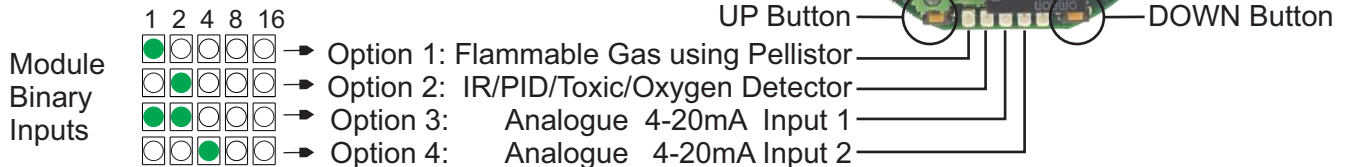
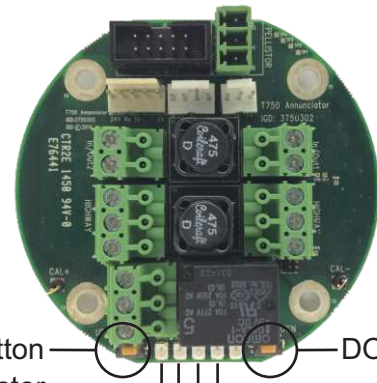

The zero sequence operates as follows:

1. Press the UP button until the LED's go out, release the UP button.
2. Select the module address that requires zero by using the up/down buttons. With the correct module input number displayed press and hold the UP button. Release when the LED's go out.



3. Use the UP/DOWN buttons to select the left LED for zero mode. With the left LED on, press and hold the UP button. Release when the LED's go out.

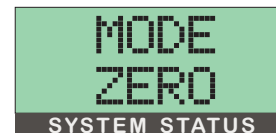

4. With a zero gas flowing and the multimeter connected as previously indicated use the UP/DOWN buttons to adjust the meter reading to 1.00V for zero. Note if a display is fitted it will indicate the LEL level at the same time.

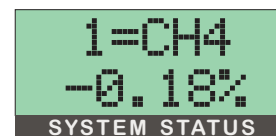
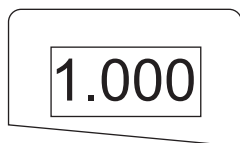

5. With 1.000V displayed (or as close as possible), gas flowing and the reading stable press and hold the Up to update the zero point

6. Each LED will blink in series to indicate the update and the module will go back to normal operation. In this example the LED's indicate the Pellistor, Input 1 and Relay are active options on the module.

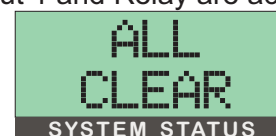
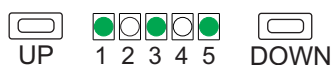

Indications are shown below to show the module LED's at each step and LCD display indications if a display is fitted.

NOTE: There is no ABORT option so before selecting to zero ensure all necessary equipment as previously indicated is available.

Detector Cal Sequence

The module PCB has four inputs which can be enabled and calibrated locally using the equipment set previously described. When the module PCB is powered and as described in the indications section, the LED's will indicate which options are enabled .

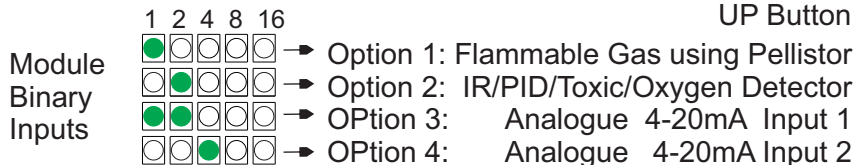
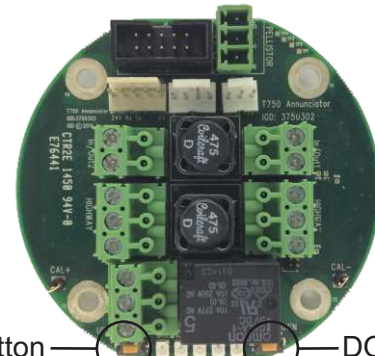

UP Button DOWN Button

The Cal sequence operates as follows:

1. Press the UP button until the LED's go out, release the UP button.
2. Select the module address that requires calibration by using the up/down buttons. With the correct module input number displayed press and hold the UP button. Release when the LED's go out.



3. Use the UP/DOWN buttons to select the Right LED for Cal mode. With the right LED on, press and hold the UP button. Release when the LED's go out.



4. With a suitable Calibration gas flowing and the multimeter connected as previously indicated use the UP/DOWN buttons to adjust the meter reading as follows. As previously described zero =1.000V on the connected multimeter. The range of the detector is then represented on the meter from 1.000V to 2.000V. So for instance a flammable gas detector ranged 0-100% LEL, if using 50% LEL as a calibration gas will require adjusting so the meter reads 1.500V Note if the display is fitted it indicates the LEL value.

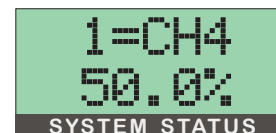

5. With 1.500V displayed and stable press and hold the Up to update the cal point
6. Each LED will blink in series to indicate the update and the module will go back to normal operation. In this example the LED's indicate the Pellistor, Input 1 and Relay are active options on the module.

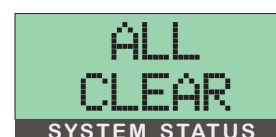
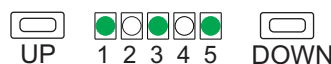

Indications are shown below to show the module LED's at each step and LCD display indications if a display is fitted.

NOTE: There is no ABORT option so before selecting to calibrate ensure all necessary equipment as previously indicated is available.

Reset to Defaults

If required the module can be reset back to a default state. The diagram below indicates the sequence to do this.

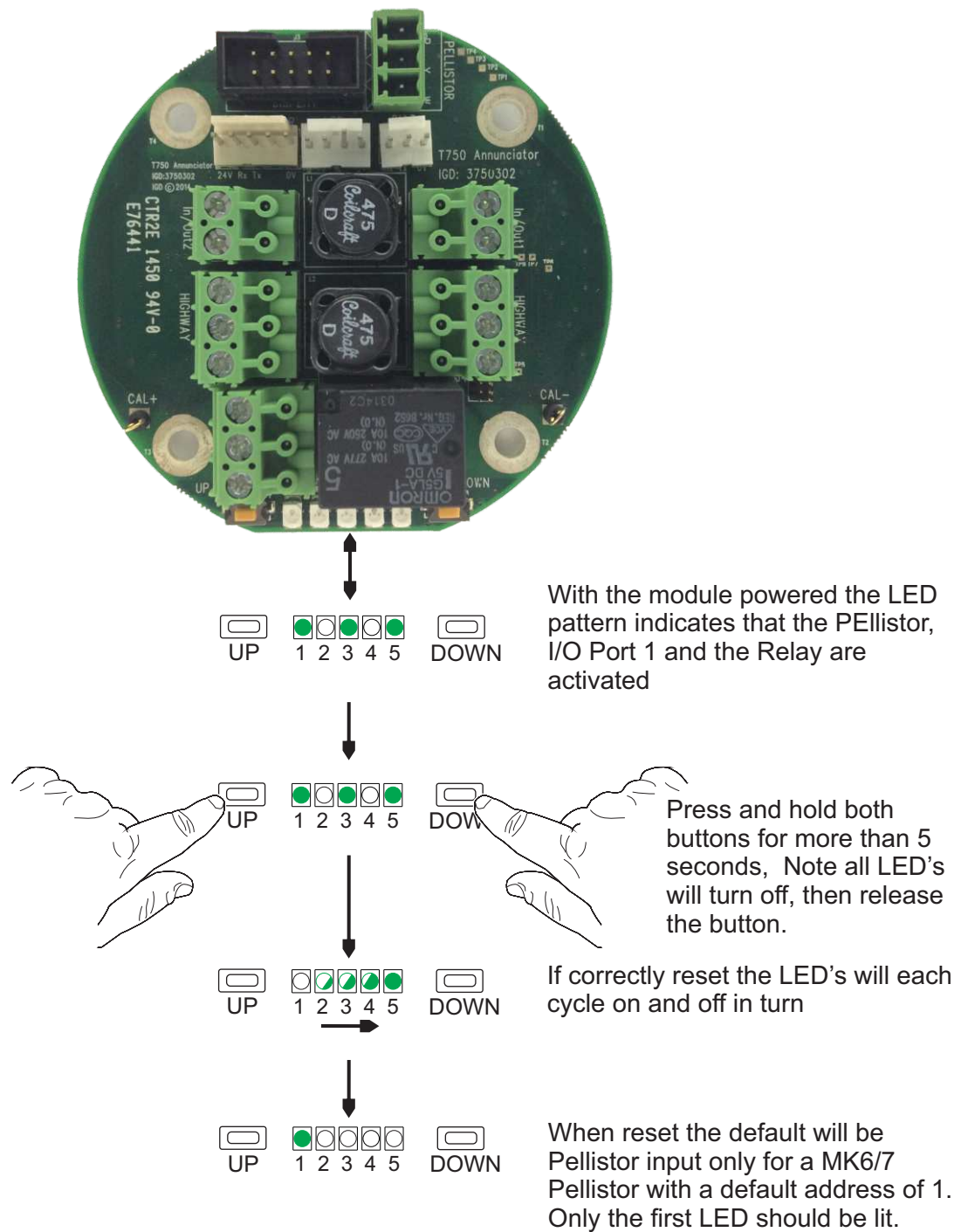

EC Declaration of Conformity

Issuers name and address:

Oliver IGD Limited of
Triton House
Crosby St,
Stockport,
United Kingdom



Declares that the product listed as:

TOCSIN 750 SERIES ANNUNCIATOR
Addressable 2-Wire Gas Detection System I/O Point

Are in conformity with the provisions of the following European Directive(s) when installed, operated, serviced and maintained in accordance with the installation and operating instructions contained in the product documentation.

2004/108/EC	EMC Directive
2006/95/EC	Low Voltage Equipment Directive (note not applicable to 24V DC Powered Versions)
And that the standards and/or technical specifications referenced below have been applied or considered.	
EN 61779-1:2000	Electrical apparatus for the detection and measurement of flammable gases, general requirements and test methods.
EN 50271:2010	Electrical apparatus for the detection and measurement of combustible gases, toxic gases or Oxygen: requirements and tests for apparatus using software and or digital technologies. <i>Excluding requirements for SIL</i>
EN 61000-6-2: 2005	EMC Generic standards. Immunity for industrial environments
EN 61000-6-4: 2007/A1: 2011	EMC Generic standards. Emission standard for industrial environments
EN 61000-3-2: 2014	EMC Limits. Limits for harmonic current emissions (equipment input current ≤ 16 A per phase)
EN 61000-3-3: 2013	EMC Limits. Limitation of voltage changes, voltage fluctuations and flicker in public low-voltage supply systems, for equipment with rated current ≤ 16 A per phase

Technical File Reference T750ANN-TF9

Product Markings  **TOC-750-ANN** *SI*-serial number

Oliver IGD Limited Operate and Independently assessed ATEX/IECEX QAN.

Oliver IGD Limited operate an independently assessed ISO9001:2008 Quality Management System.

Testing Agency:

TUV - SUD
Octagon House
Concorde Way
PO 15 5RL
Fareham

Quality Assurance Certificate Number
ExVeritas 16PQAN0014

Quality Management Certificate Number
FS 646773

Quality Assurance Notification Number:
2585

ExVeritas,
Units 16-18,
Abenbury Way,
Wrexham Industrial Estate,
Wrexham, UK, LL13 9UZ

BSI Assurance UK LTD,
Chiswick High Road,
London
W4 4AL
UK



Mehr Sicherheit.
Mehr Wert.

TUV Certificates and reports can be checked on-line at https://www.tuev-sued.de/industry_and_consumer_products/certificates

Issued by: Oliver IGD Limited, Stockport, SK2 6SH , United Kingdom

Signature:



Declaration of Conformity in accordance with EN ISO/IEC 17050-1:2010

Name

Andrew J Collier M.I.O.D

Position:

Managing Director

Date: 1.June 2016

Declaration Ref: T750ANN-DEC-2