

# SHKM-355

Shock Mount for Model 355 (5....250Kg)

**SENSOR**  
TECHNIQUES LIMITED



## Shock Mount for Model 355

- Anti vibration and shock absorbing
- Self aligning, reduces the effect of side loads
- Ensures optimum performance from the load cell
- Suitable for use on capacity ranges up to 250kg
- Ideal for small hopper and tank weighing
- Low cost, compact design
- Optional alloy steel base kit

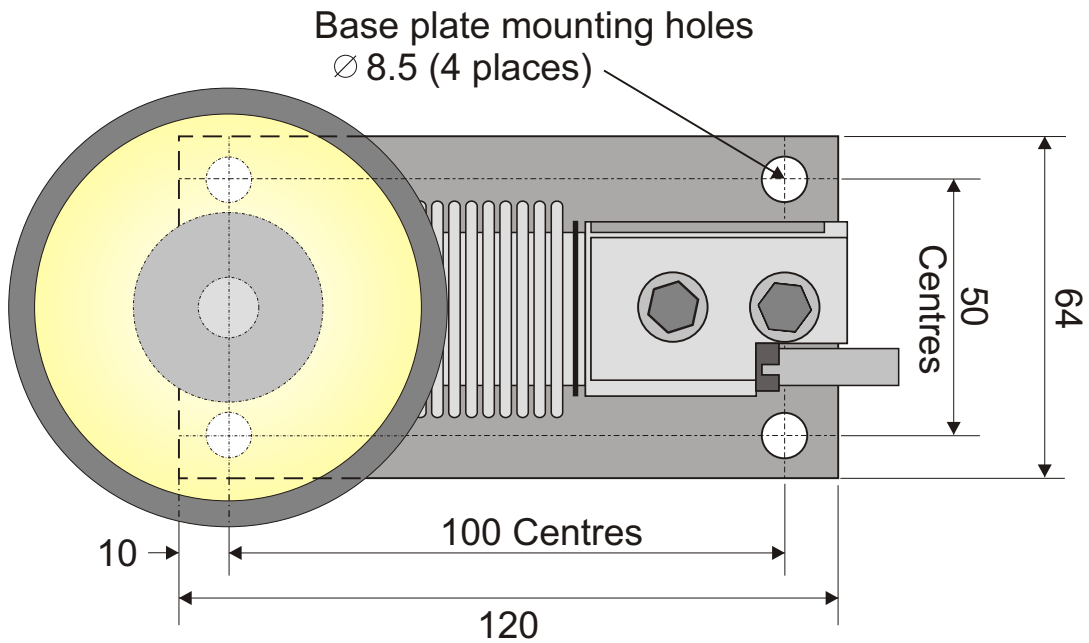
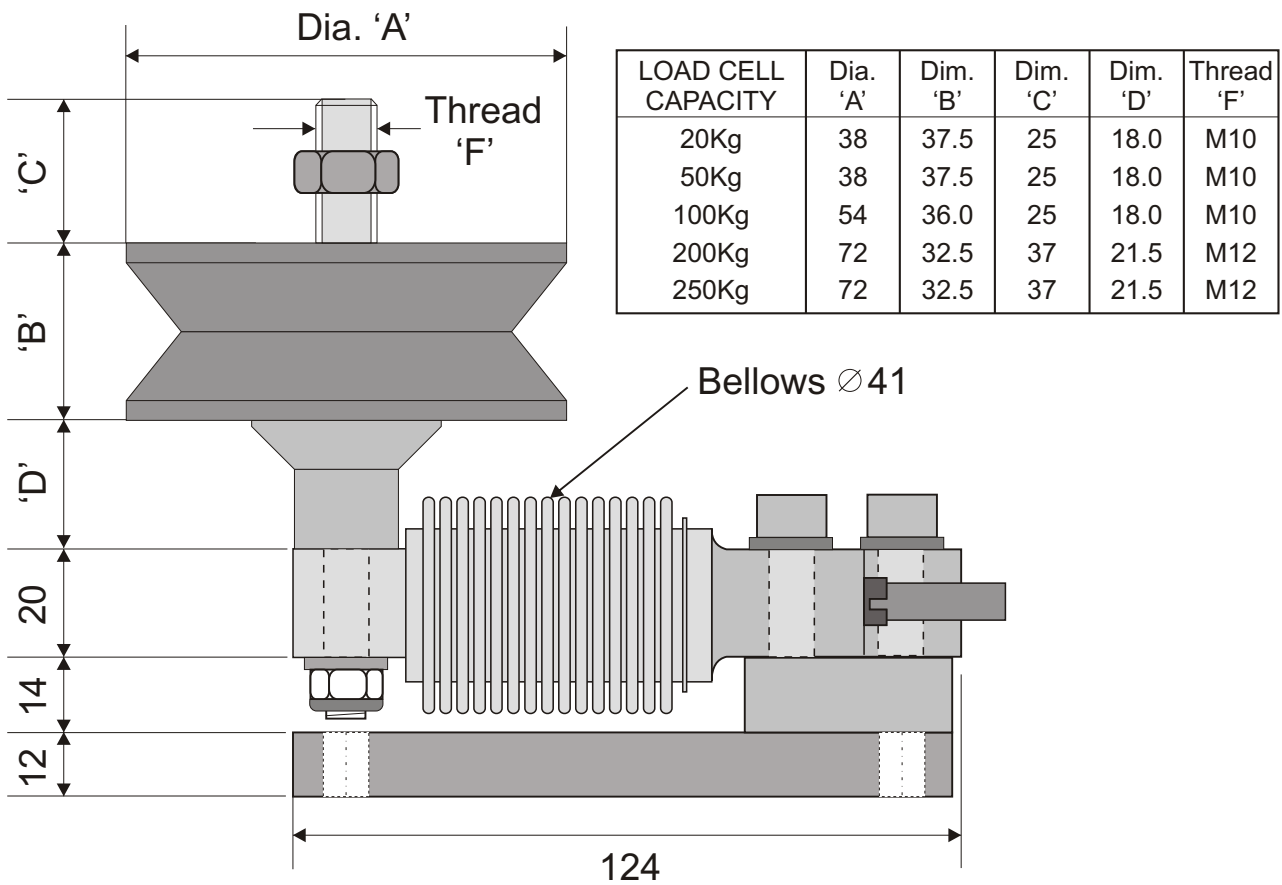

All Dimensions in mm  
 Specifications are subject to change without prior notice

DSSHKM355-5, 12/09