

1260

Platform Load Cell

SENSOR
TECHNIQUES LIMITED

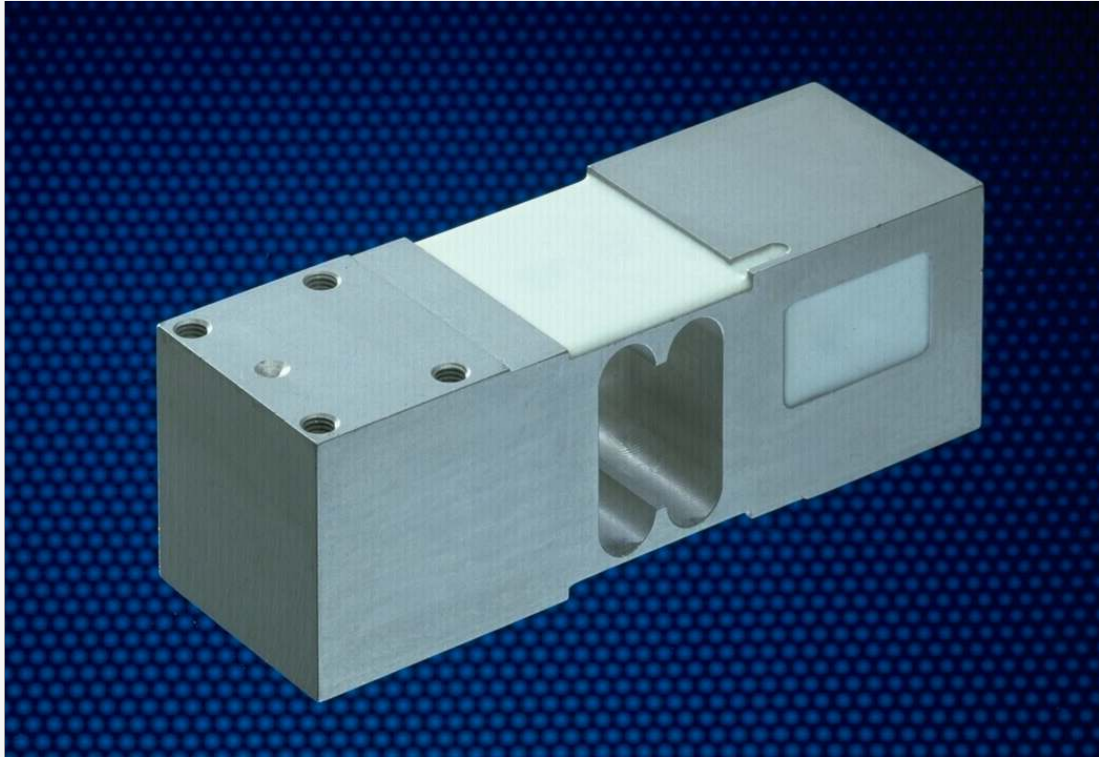

Platform Load Cell, Model 1260

- Approved to OIML R60 3000 D
- Total Error 0.020 %
- Maximum platform size 600 x 600 mm
- Available in capacity ranges from 30kg to 635kg
- Ideal for platform, tank and floor scales
- Compact aluminium construction
- Sealed to IP66 with a special coating
- 6-wire sense technique with double shielded cable
- Optional Hazardous area approval (ATEX) available

Technical Data

Model 1260

GRADE		E	G	C3
Number of Load Cell Intervals	n (max)			3000
Minimum Utilisation	% Rated Cap.			30
Minimum Verification Interval	Vmin=Emax/.			10000
Total Error	% Appl. Load	0.050	0.020	0.020
Zero Return after 30 mins	% Appl. Load	0.050	0.017	0.017
Temperature Effect on : Span	%Appl. Ld./10K	0.030	0.010	0.010
Zero	%ORL/10K	0.100	0.040	0.014
Output at Rated Load (ORL)	mV/V		2	
Output at Rated Load Tolerance	%		± 10	
Input Impedance	Ohm		415 ± 15	
Output Impedance	Ohm		350 ± 3	
Recommended Supply Voltage	V		10	
Compensated Temp. Range	°C		-10 to +40	
Operating Temperature Range	°C		-20 to +70	
Deflection	mm		< 0.4	
Safe Overload	% Rated Cap.		150	
Maximum Overload	% Rated Cap.		200	
Ultimate Overload	% Rated Cap.		300	
Cable Length	m		3	
Typical Platform Size	mm		600 x 600	
Environmental Protection			IP66	
Rated Capacities (Emax)	Kg	30, 50, 75, 100, 150, 250, 300, 500, 635		

NMI - Certificate TC2559, OIML-R60

Dimensions

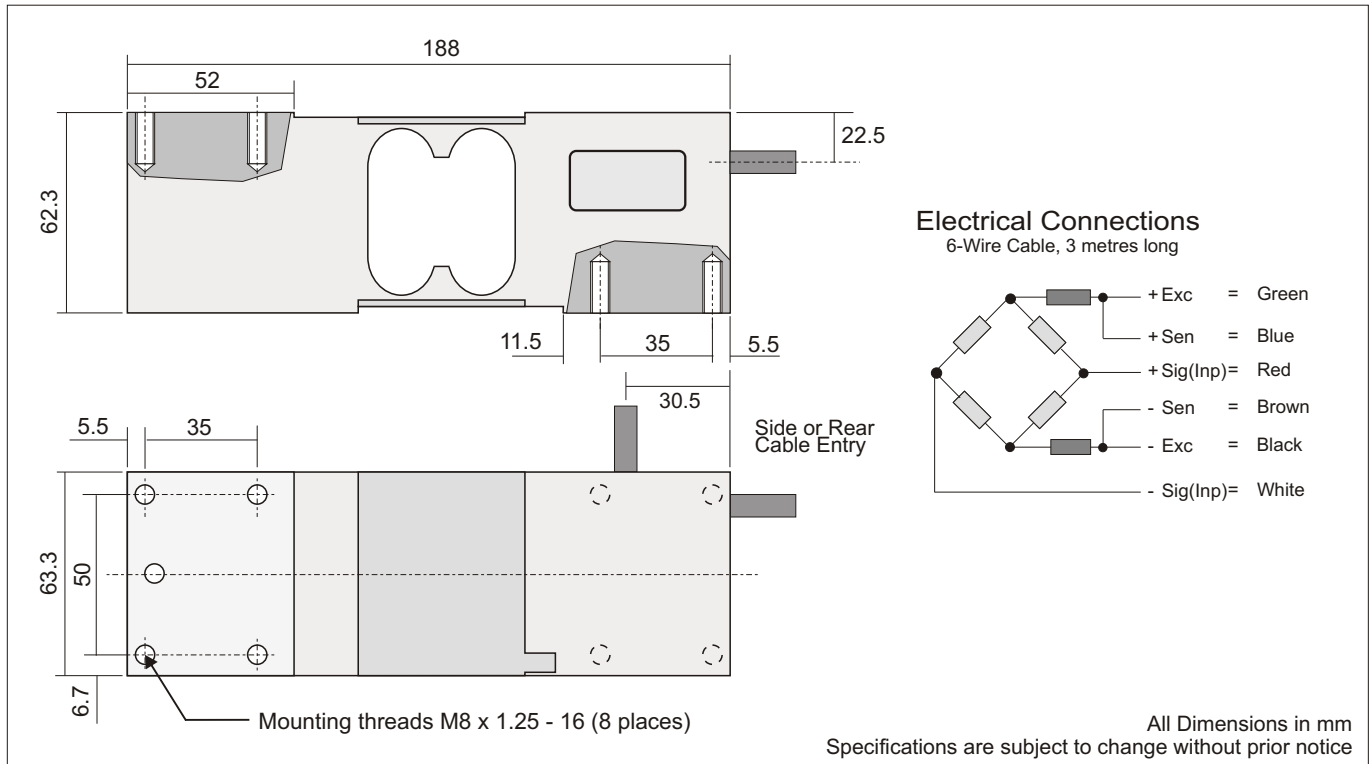

DS1260-4, 08/10

SENSOR

TECHNIQUES LIMITED

Tel. +44 (0)1446 771185 Fax +44 (0)1446 771186

Precision Load cells
 Accessories and Mountings
 Measuring Instruments and Systems