



CHICK

Efficiency Through Workholding Innovation



OneLOK™

OneLOK™

Setup and Go

Re-engineered from the ground up for vertical milling machines running fewer than 20 parts, the OneLOK's design captures dramatic improvements in speed, precision, and versatility.



Setup Quicker

Our BoltFast™ jaw system shaves valuable time off of jaw changes. One simple screw turn provides fast precise repeatability. Stop wrestling with buried screws, stop recutting jaws, and start saving time.

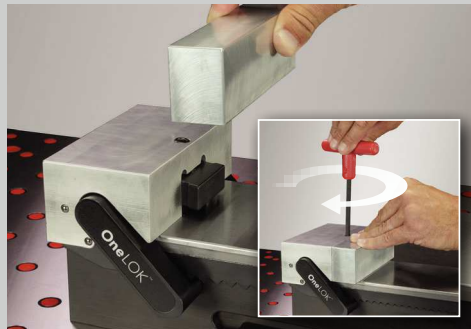

Operate Easier

We designed the OneLOK with the machinist in mind. At nearly half the weight of 1950 style vises and with an ergonomic handgrip, the OneLOK can be handled with ease.



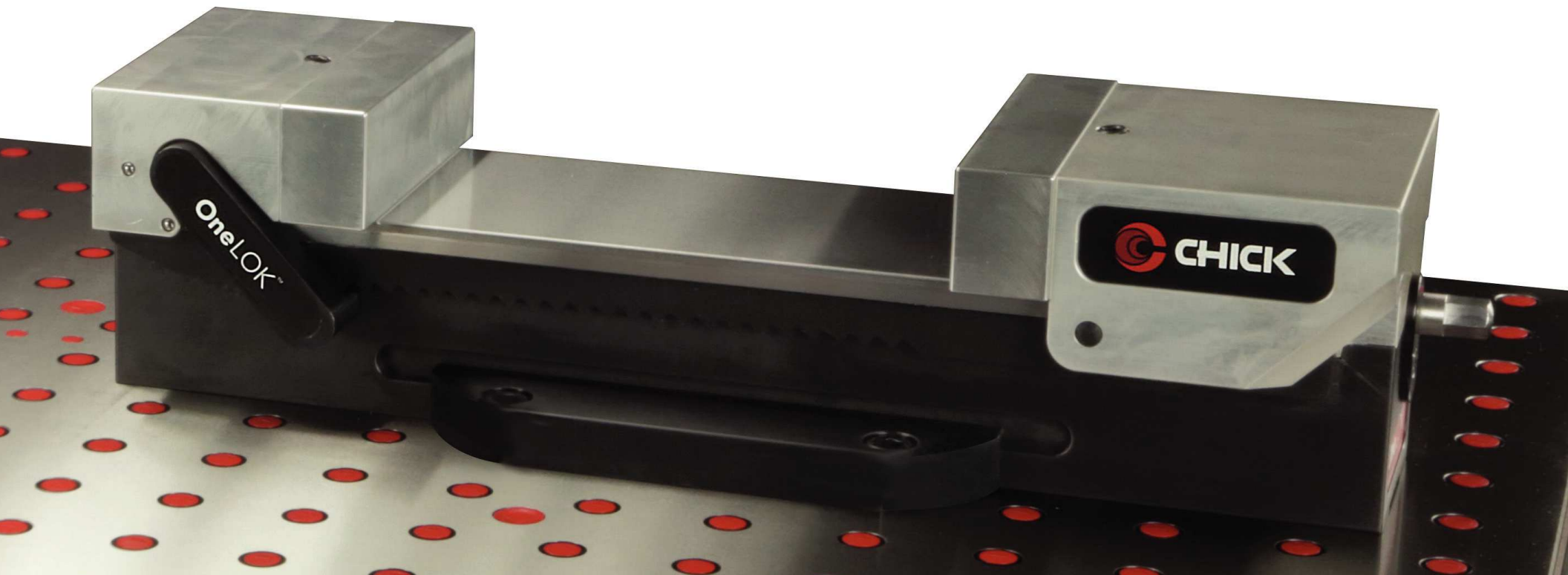

Work Cleaner

OneLOK's sealed design eliminates "chip traps" for cleaner operation and less aggravation. This means no more messy part changes or lost small workpieces.



Clamp Faster

The QwikSlide movable jaw slides with ease for rapid setup and part changes. Boost operator speed and gain efficiency.



OneLOK™

System Information

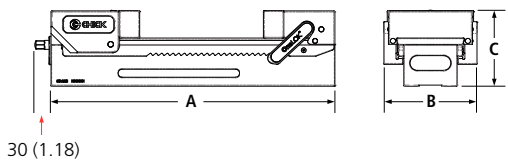
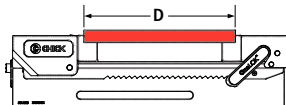
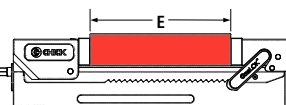
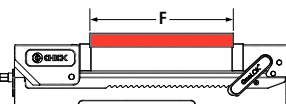

ORDER NUMBERS	50L1540	50L1550
Dimensions mm (inch)		
 <p>A Length</p> <p>B Width *</p> <p>C Height *</p>	<p>400 (15.75)</p>	<p>500 (19.69)</p>
Maximum Holding Capacity mm (inch)		
 <p>D Machinable Jaws</p>  <p>E Hard Jaws</p>  <p>F Step Jaws</p>	<p>180 (7.08)</p> <p>158 (6.22)</p> <p>163 (6.42)</p>	<p>280 (11.02)</p> <p>258 (10.16)</p> <p>263 (10.35)</p>
Additional Information on Jaws and Accessories	Pages 4-6	
Clamping Force @ Maximum Torque	<p>26.7 kN @ 67.8 N•m</p> <p>6000 lbs @ 50 ft•lbs</p>	
System Weight	18.7 kg (41.3 lbs)	21.6 kg (47.7 lbs)

*All dimensions and systems include a standard BoltFast™ machinable jaw set. Performance will vary depending on the application.

OneLOK™ BoltFast™ Jaws

Machinable Jaw Set



Material: High Strength Aluminum

Order Number	Length	Width	Height
Set includes 2 jaws			
5BFSJ-150-50	152 (5.98)	36 (1.42)	48.5 (1.91)

Clamp workpieces securely with BoltFast™ jaws. In addition to the included standard machinable jaws, choose hard jaws or step jaws. All have locating features with precise repeatability, reducing setup time to seconds.

Hard Jaw Set



Material: Hard Steel

Order Number	Length	Width	Height
Set includes 2 jaws			
5BFHJ-150	152 (5.98)	21 (.83)	50 (1.97)

Step Jaw Set



Material: Hard Steel

Order Number
Set includes 2 jaws
5BFST-150-06

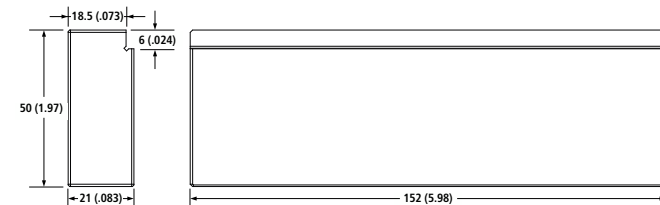

OneLOK™ WorkStop

Brace yourself for a workstop solution that finally lets you make unlimited adjustments on the fly. Chick's WorkStop is versatile, with full 360-degree rotation and lateral calibrating. It's also rugged – built to handle accurate, repeatable locating, time and time again. Put stopping power where you need it. (Mounts to OneLOK, Foundation, and T-slotted tables.)



OneLOK Order Number: **5WS-OL**



Foundation Order Number: **5WS**

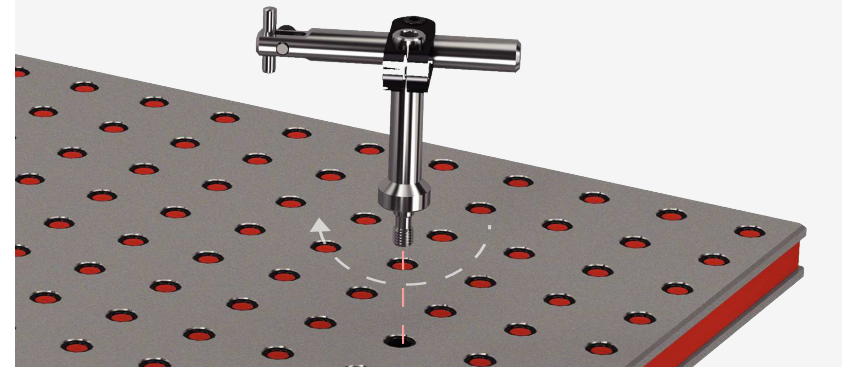

T-Slotted Table Order Number: **5WS**

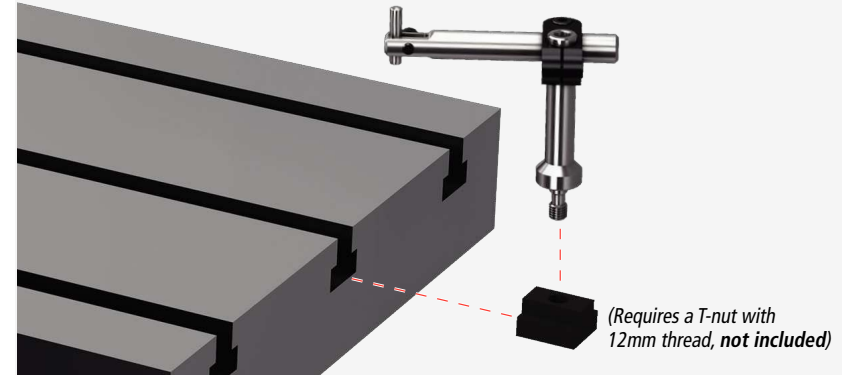

OneLOK™ Mounting Accessories

Mount to a Chick Foundation

Our advanced locating system ensures pinpoint-accurate mounting. Whether you're orienting your system in the X or the Y axis, simply place OneLOK onto the Chick foundation, and use the round and diamond pin interface to ensure precise locating accuracy and repeatability. Then add Foundation Toe Clamps on each side to secure the OneLOK.

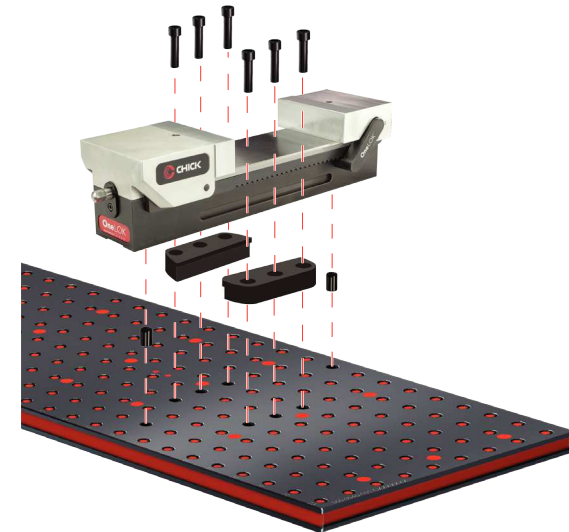

Mount to a T-Slotted Table

Alternatively, the OneLOK can be mounted to a T-slotted table with T-slot Toe Clamps.



Toe Clamps (four per set) mount a OneLOK to a T-slotted VMC table. Toe Clamps can be used with either a 1/2-13 or M12 socket-headed cap screw. (T-nuts and cap screws not included).

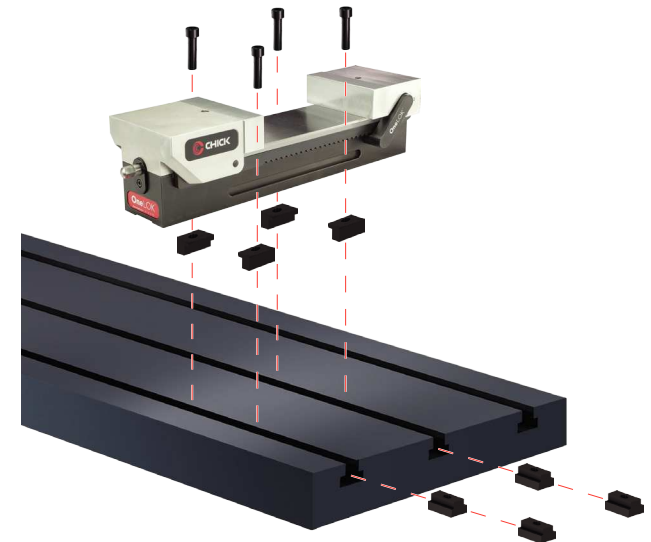



Chick Workholding Solutions, Inc.
500 Keystone Drive
Warrendale, PA 15086

Phone: 724.772.1644
Fax: 724.772.1633
Email: Info@ChickWorkholding.com

ChickWorkholding.com