

HI-700W

high speed
wide automatic
weigh price labeller



Industrial PC based system
offering flexible integration.



Quick release conveyors provide
easy cleaning and replacement

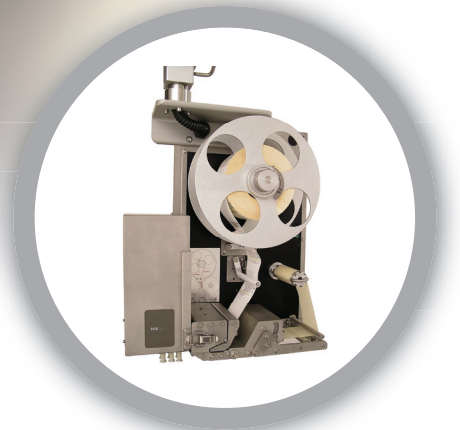

High Speed labelling system
fitted as standard.

*The HI-700W is provided with a single High Speed labeller as standard (machine pictured presents additional base labeller) many other variants available.

Digi - a leading company in PC Based weigh price labelling systems

The Digi HI-700W is a Wide high speed, dynamic weigh price labeller utilising embedded software on a Windows® operating system and capable of operating up to 120ppm.

Using the latest technology available, the architectural design of the system provides full integration with existing Digi systems as well as suitability to new production lines. Bi-directional communications in XML format provides back office server data collection and is complemented by online programming and line monitoring. Colour touch screen for quick and easy programming and PLU selection.

The HI-700W has been designed to be compatible with a variety of Digi labellers and total printers as well as external devices such as metal detectors, sleeves, scanners and wrappers.

Machine Options



HI-700W

The HI-700W is supplied with a single top High Speed labeller and integrated pack guides as standard.

The High Speed labeller can accommodate a large label roll and offers near edge printing eliminating the need for extra backfeed equipment.

The 400mm wide conveyor system enables the process of weighing and labelling packs of up to 410mm wide and at a constant speed of up to 120ppm.

Additional Options

The modular design of the 700 series allows the HI-700W to manage multi-labeller systems. Benefitting from up to 5 integrated top and bottom labeller stations and enabling labeller swapping, multiple labels per pack and offering the added flexibility to label both the top and under side of each pack simultaneously.

Optional Labellers

	Classic Labeller	Cassette Labeller
Print Head:	80 or 108mm @ 300dpi	80mm @ 300dpi
Print Speed:	260mm/sec	200mm/sec
Label Size:	W - 30 to 120mm H - 28 to 150mm	W - 40 to 80mm H - 28 to 80mm
Label Roll:	Diameter 300mm (Core diameter 76mm out or inside wound)	Diameter 190mm
Applicator:	Concave/Air/Touch	Touch
T/Transfer:	Yes	N/A
Backfeed:	Yes	Yes

Specifications

Power:	220-240V AC 50Hz 105-115V AC 60Hz
Air:	4-6 bar / 58-87psi / 50-300 ltrs/min
Capacity:	3kg/1g 6kg/1g 12kg/2g
Pack Speed*:	up to 120ppm * dependant on pack and label size
Pack Size:	L 80-300mm W 40-410mm H 180mm
Pack Guide:	Adjustable guides
Print Head:	80mm or 108mm(opt) @ 300dpi
Print Speed:	260mm/sec
Label Size:	W 30mm-120mm H 28mm-150mm
Label Roll:	Diameter 300mm
Label Core:	Diameter 76mm out or inside wound
Applicator:	Air Box Type or Touch
Other:	Powerlift (assisted labeller height adjustment)

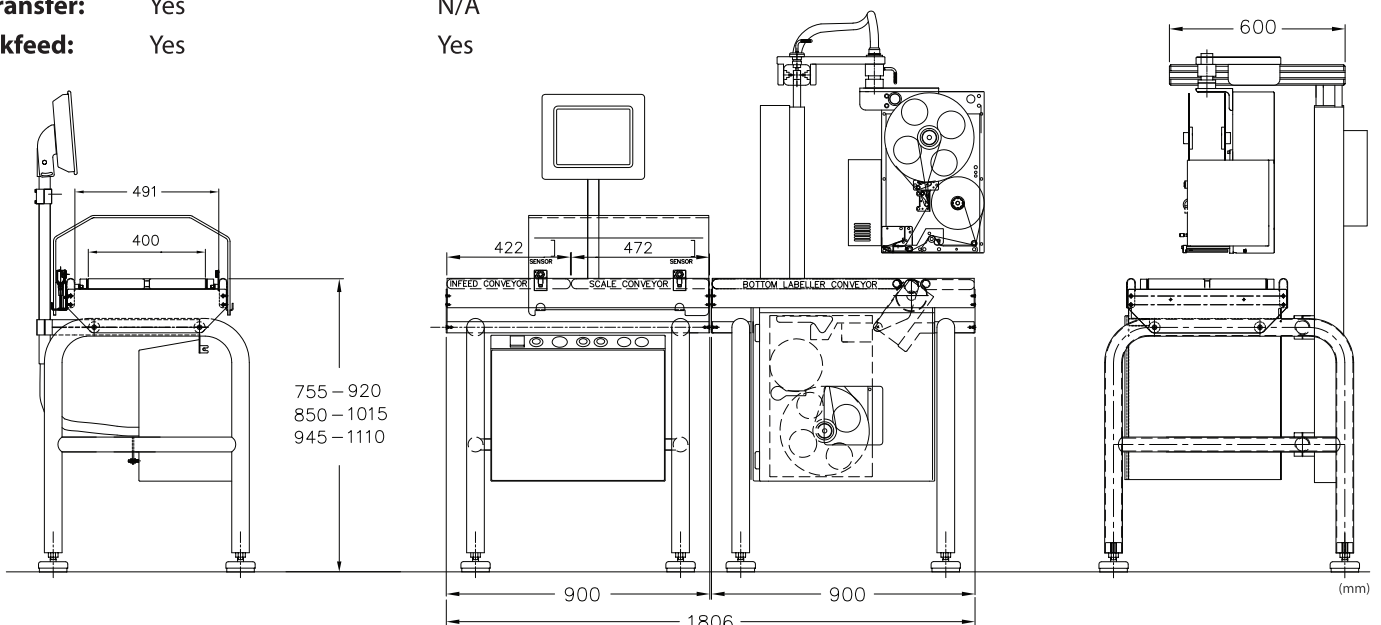
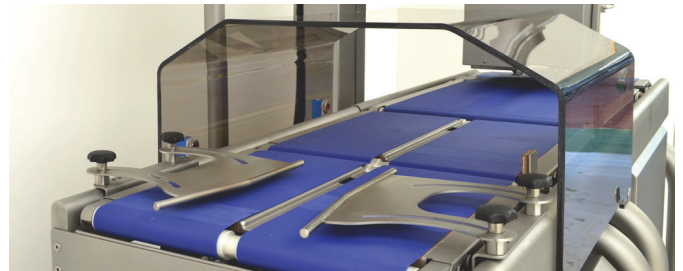

* Custom options available, please contact sales@digico.uk

Issue 2. Document subject to change without notice (E.&O.E) ERRORS AND OMISSIONS EXCLUDED.