



SCOTSEAT

Direct Limited

Comfort and safety
when you need it most



Comfort and safety when you need it most



Scot Seat Group, established in 2000 are UK based designers and manufacturers of specialist seating for the transportation market.



Call our sales team on
0845 643 4248
for further information

The Group incorporates Scot Seat Direct Ltd and Scot Seat KPM Marine. Scot Seat Direct Ltd is the market leader in seating manufacture for commercial vehicles, buses, trains, fire engines and military use. Scot Seat KPM Marine provide specialist shock mitigation seats for use by rescue services, military operators, police forces as well as commercial boat operators.

Scot Seat Group is a family owned and operated business based in Ayrshire, Scotland with in-house skills ranging from metal fabrication, joinery, upholstery, spray painting/coating to composite manufacture facilitating both small and large orders to customers' specific requirements. The company manufacture approximately 12,000 commercial vehicle seats per year, as well as numerous customised specialist seating and mounting systems.

Manufacturing lead times are generally short and Scot Seats has a nationwide fitting service with fully trained technicians to service customer needs. All seats comply with regulations pertaining to each industry for which they are intended and the team work closely with their customers advising and assisting with the specification.

Scot Seats are dedicated to improving the comfort and safety for all transportation seating needs.

San Carlos

High Back Seat Range

N1, M1 AND M2 TESTED TO ECE REGULATIONS

San Carlos High Back Seat

The San Carlos High Back Seat is one of our most popular seats due to its simple compact design while offering optimal comfort and class leading safety. The seats tubular one piece CNC formed frame and laser cut components make the San Carlos High Back Seat one of the lightest and strongest seats on the market.

San Carlos Deluxe High Back Seat

The San Carlos Deluxe High Back Seat is based on the popular San Carlos High Back Seat with wider frame options of 450 and 500mm overall and with extra comfort foam and deluxe upholstery fully customisable with embroidery, armrests and endless trim design options. You will not find a more comfortable seat.

San Carlos High Back Seat Recliner

Both the San Carlos High Back and San Carlos Deluxe High Back Seats are available with optional reclining backrest. This allows easy adjustment of the seat back angle for those extra long journeys.





San Carlos

Low Back Seat Range

M1 - M3, N1 - N3 Tested to all relevant ECE Directives

San Carlos Low Back Seat

The San Carlos Low Back Seat is based on the market leading San Carlos High Back Seat with a lower backrest which allows for the fitment of optional fixed or adjustable head restraints. The San Carlos Low Back Seat still offers the same levels of comfort and safety as the High Back version.

San Carlos Deluxe Low Back Seat

The San Carlos Deluxe Low Back Seat is part of our popular San Carlos range and is one of the most comfortable seats on the market with side bolsters giving the occupant the added feel of security. The lower backrest allows for the optional fitment of a fixed or adjustable head restraint. The seat offers the levels of safety and occupant protection you would expect from all Scot Seats.

San Carlos Low Back Seat Recliner

Both the San Carlos Low Back and San Carlos Deluxe Low Back Seats are available with optional reclining backrest, which allows you to adjust the seat back angle for comfort to suit the occupant.





San Carlos High Back Seats ▾

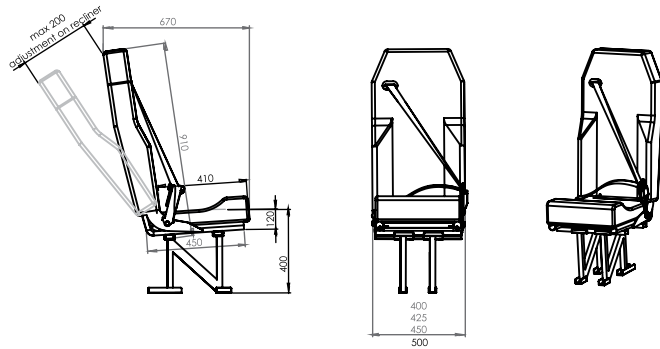

San Carlos Low Back Seats ▾

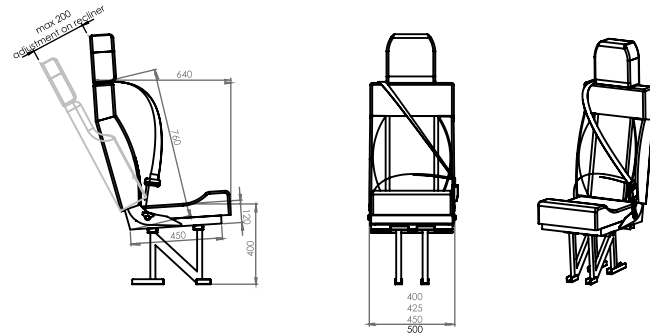

San Carlos Self Standing Flip-up Seat

M1 - M3, N1 - N3 Tested to ECE Directives

The San Carlos Flip-up Seat is available in Standard or Deluxe, High and Low back variations. It is normally used in areas where space is at a premium when the seats are not in use. It offers the same levels of comfort and safety as the rest of the San Carlos seat range.

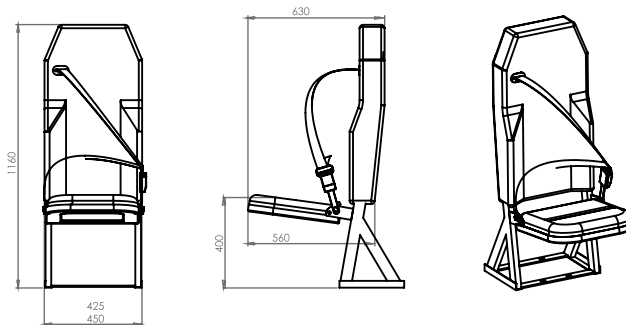

San Carlos

Range Specifications

Key																	
	PU moulded comfort seat foams	extra comfort foam & deluxe upholstery	grey or black cloth or vinyl	manufacturers matching trim	custom leather	3 point seat belt	all age seat belt	4 point harness	isofix mounts	adjustable armrests	sprung seat base	adjustable lumbar support	magazine net	custom embroidery	waterproof protective cover	bolt down	quick release mountings
High Back Seat	S	-	S	O	O	S	O	O	O	O	O	O	O	O	O	S	O
Deluxe High Back Seat	-	S	S	O	O	S	O	O	O	O	O	O	O	O	O	S	O
High Back Seat Recliner	S	-	S	O	O	S	O	O	O	O	O	O	O	O	O	S	O
Low Back Seat	S	-	S	O	O	S	O	O	O	O	O	O	O	O	O	S	O
Deluxe Low Back Seat	-	S	S	O	O	S	O	O	O	O	O	O	O	O	O	S	O
Low Back Seat Recliner	S	-	S	O	O	S	O	O	O	O	O	O	O	O	O	S	O
Self Standing Flip-up Seat	S	-	S	O	O	S	O	O	O	O	O	O	O	O	O	S	O

Scot Seats

Multi-Van Rail

M1 - M3, N1 - N3 Tested to ECE Directives

Scot Seats Multi-Van Rail is a lightweight aluminium bonded floor system suitable for M1-M3 and N1-N3 fitments. Multi-Van Rail can be fitted in lengths of 1000mm up to 4700mm and comes in either plain rail for static seat fitment or drilled rail for use with quick release seat fittings like NMI, Unwin, Kollar, QStraint etc.

Multi-Van Rail is tested to all ECE Directives with the full San Carlos range of seating making it perfect for all types of conversions from welfare vans to fire engines and minibuses to ambulances.

Multi-Van Rail Tested Vehicle List

Make	Model
Mercedes	Vito, Sprinter
VW	Crafter, T5, T6
Citroen	Dispatch, Relay
Peugeot	Expert, Boxer
Fiat	Scudo, Ducato
Vauxhall	Vivaro, Movano
Renault	Master, Trafic
Ford	Transit Custom, Transit
Iveco	Daily

If your vehicle is not listed please contact us.



Scot Seats are also tested and compatible with most other bonded floor systems including unwin innotrax and smartfloor.



4x4 Commercial Seats

M1 Tested Specification Fitment

Available for all models of 4x4 commercial vehicles.

The 4x4 commercial seat kit is a full width 3 seat forward facing fold up seat fitted with 2 x 3 point inertia reel lap and diagonal seat belts and 1 x centre lap seat belt. Its two stage folding system allows you to maximise the load space in your vehicle when the seat is not in use.

Some 4x4 commercials have the option to have 3 x fixed San Carlos Low Back Seats instead of the fold up seat which allows 3 point seat belts to be fitted in all positions.

Standard Specification:

- 2 Stage fold-up system
- High quality comfort seat and back foams
- Can be trimmed in vinyl, cloth, leather or manufacturers matching trim
- Optional Isofix mountings

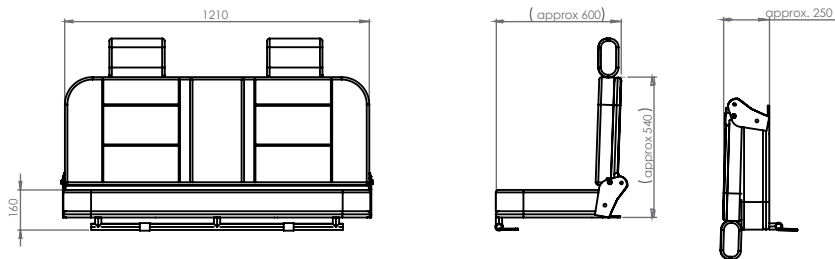

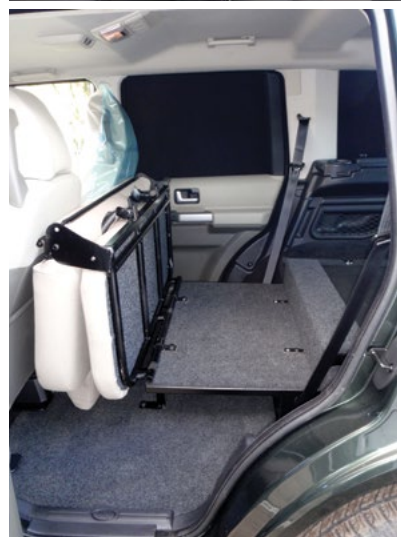
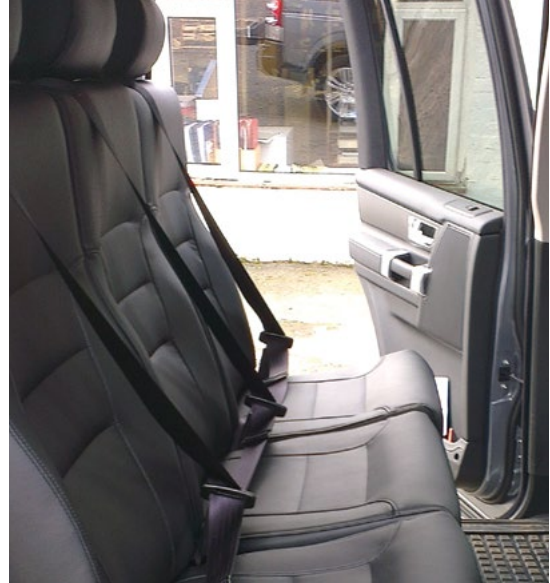

Car Derived Van Seats

M1 Tested Specification Fitment

Available for all models of car derived vans.

The Car Derived Van seat kit is a full width 3 seat forward facing fold up seat fitted with 2 x 3 point inertia reel lap and diagonal seat belts and 1 x centre lap seat belt. When the seat is not in use it folds forward leaving a large area for goods and creating a half height bulkhead.

Some car derived vans can also be fitted with 1, 2 or 3 fixed San Carlos High or Low Back Seats meaning all seat positions can have 3 point inertia reel seat belts.

Standard Specification:

- 2 Stage fold-up system
- High quality comfort seat and back foams
- Can be trimmed in vinyl, cloth, leather or manufacturers matching trim
- Optional Isofix mountings

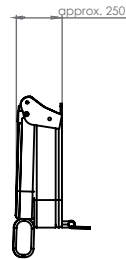
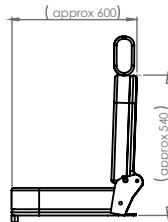
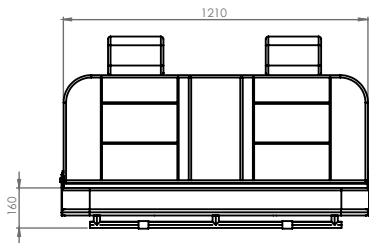



Rear Facing Flip-up Seats (Taxi Bulkhead Seats)

M3 Tested to ECE Directives

Rear Facing Flip-Up Seats designed specifically for taxi conversions but also used in commercial vehicles when a compact solution is essential. Available in 2 or 3 seat options depending on the vehicle and with basic or deluxe upholstery. For some vehicles the frame is stepped around the drivers seat to allow wheelchair access on passenger side (available for RHD or LHD vehicles).

Standard Specification:

- Spring / hydraulic assisted flip-up seat bases
- High quality PU moulded foam seat and back foams
- 3 point inertia reel lap and diagonal seat belt
- Can be trimmed in vinyl, cloth, leather or manufacturers matching trim

Optional Extras

- Carpet trim panels
- ABS plastic trim panels (contact for more details)
- Polycarbonate full height screen with cash hatch
- Wheelchair hold down kit
- Grab handles

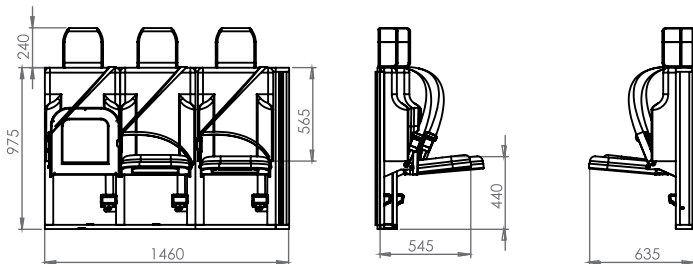

We can also supply other components for your taxi conversion requirements including ramps, side steps and intercoms contact us for more information.

If you are looking to build a vehicle for IVA, NSSTA or ECWVTA approval our technical and design team can help you through the whole process.



Bulkhead / Wall Mounted Flip Up Seat

M3 & M1 Tested Specification Mountings

The Bulkhead / Wall Mounted Flip-Up Seat is a compact seat with spring assisted base designed to be fitted in areas where space is an issue and therefore this compact seat can be manufactured in dimensions to suit the customers exact requirements. In some of its uses, it has been fitted as an occasional front passenger seat in panel vans and chassis cabs where it utilises the existing vehicle seat belt. It has also been used as a control unit seat in fire and accident response vehicles, or crew seating in off road or military trucks.

Standard Specification:

- Spring assisted flip-up seat bases
- High quality PU moulded seat and back foams
- Powder coated seat frame
- ABS plastic seat base cover
- Can be trimmed in vinyl, cloth, canvas, leather or manufacturers matching trim

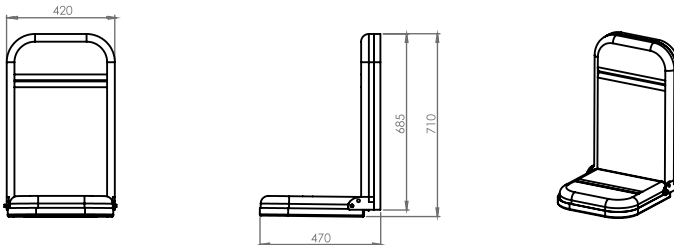

Front Passenger Flip-up Seat

M1/N1 Tested to ECE Directives for M1/N1 Category Vehicles

The Bulkhead / Wall Mounted Deluxe Flip-up Seat is a comfortable but compact seat with spring assisted flip-up base designed for fitment as a passenger seat in chassis cab conversions and panel vans with solid bulkhead. The seat utilises the existing vehicle seat belt and has been crash tested in various chassis cab and panel van bodies.

Designed specifically for parcel / home delivery vehicles, the seat allows the driver to safely enter and exit the vehicle from the passenger / kerb side while giving a comfortable seat for a passenger when required or space to locate a sack barrow when the seat is flipped up.

Standard Specification:

- Spring assisted flip-up seat bases
- Deluxe upholstery with side bolsters
- Fixed or adjustable head restraint
- High quality PU moulded seat and back foams
- Can be trimmed in vinyl, cloth, canvas, leather or manufacturers matching trim

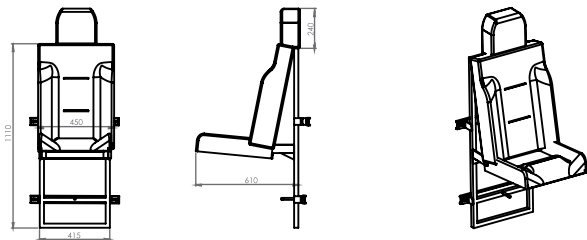

Bed Seat

M1 Tested to ECE Directives

The Bed Seat is available in 1, 2 and 3 seat options and offers unrivalled comfort and safety in both seated and sleeping positions. The seat comes as standard with sculpted deluxe seat cushioning offering great comfort when being used for passenger carrying and can be opened out to its bed position in less than 30 seconds.

The bed seat can be fitted on sliding rails allowing easy fore / aft adjustment and can be fitted in vehicles from VW Caddy size upwards. The Bed Seat can be customised to suit different vehicle fitments and there are numerous options of trim variations.

Standard Specification:

- Deluxe sculpted upholstery
- 3 point inertia reel lap and diagonal seat belt
- Adjustable headrests
- Available in various seat widths
- Powder coated seat frame
- Can be trimmed in vinyl, cloth, leather or manufacturers matching trim
- Can be fitted with our standard bolt down kit or can be fitted on a sliding rail system

Standard sizes: 600mm single / 1040mm double / 1500mm triple

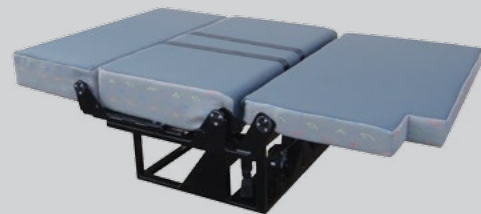

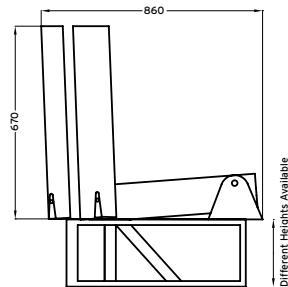
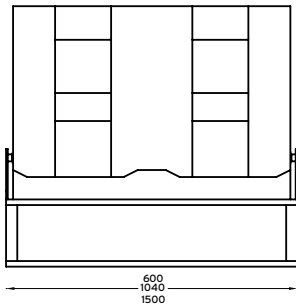
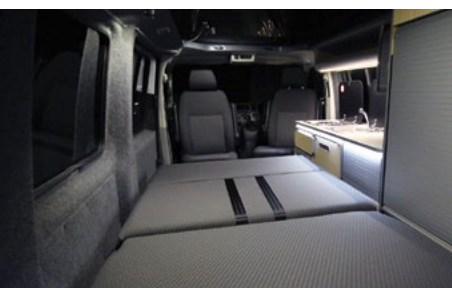

Different Heights Available

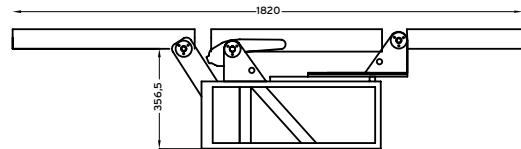

Fixed & Suspension Driver and Passenger Seats

Scot Seats can supply a range of fixed or suspension seats for vans, trucks, buses, agricultural or construction equipment and forklifts. Contact us for more information.

Standard Specification:

- Mechanical and air suspension options
- Built in seat belts where required
- Swivel seat options
- Adjustable armrests
- Recline and lumbar adjustment options
- Can be trimmed in vinyl, cloth, leather or manufacturers matching trim

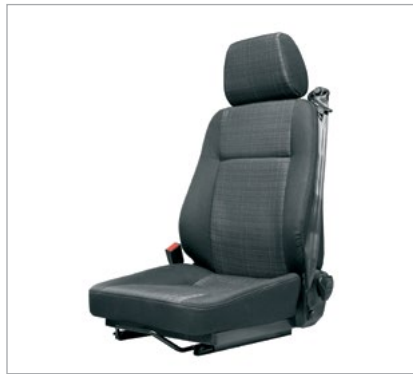

Bench & Toolbox Seats

M1 - M3, N1 - N3 Tested to ECE Directives

The Bench / Toolbox seats are the strongest commercial vehicle seat available which can be supplied in 1, 2, 3 and 4 seat options and can be fitted with either lap seat belts or 3-point inertia reel seat belts. The Inertia reel seat belt bench / toolbox seat is designed so a bulkhead can be attached directly to the rear of the seat for panel van fitments. Variations of the seat can be used for double cab pick-ups or as seating for the rear of refuse vehicles.

Standard Specification:

- 3 point inertia reel lap and diagonal seat belt
- Comfort seat foams
- Available in 2 standard seat widths
- Available in different heights
- Can be trimmed in vinyl, cloth, leather or manufacturers matching trim
- Can be fitted with our standard bolt down kit, on quick release catches or fitted on an M1 tested floor system

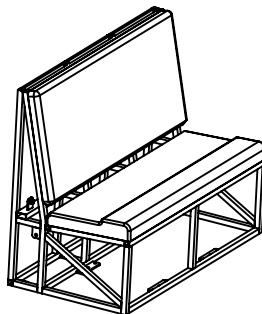
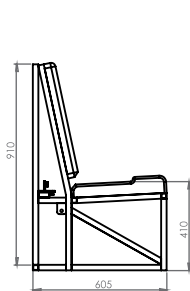
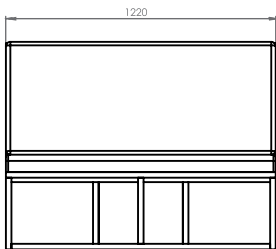

Seat Trim Options and Upholstery Customisation

Scot Seats seats are trimmed as standard in grey or black vinyl or cloth however we also stock OEM manufacturers matching trims for most models of commercial vehicles. Visit our website to see a complete list.

We also offer custom service where you can design the upholstery finish of your seats with a vast range of trim options available from carbon fibre effect vinyl to the highest quality napa leathers with top stitching or piping, diamond stitch panels or perforated panels. Custom embroidery can also be added.

Contact us for more details on seat customisation.



Scan to view the full trim range on our website.

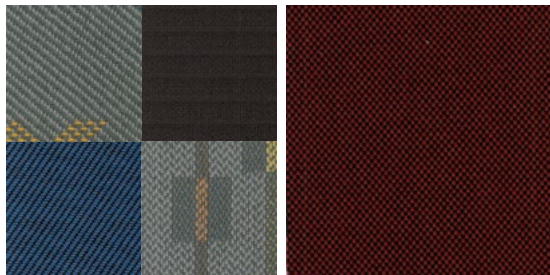

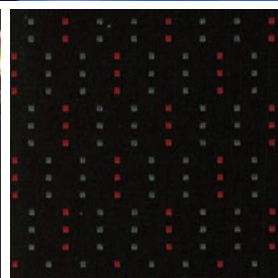

Optional Extras

Optional Extras

- Fixed, adjustable upholstered headrests
- Fixed or adjustable see through moulded headrests
- Fixed headrest with grab handles
- Folding / adjustable armrests
- Lumbar support
- ISO Fix Child Seat Mounts
- Heated seat elements
- Sprung seat bases - for unrivalled comfort
- Moulded memory foam seat cushions for San Carlos Seat Range
- Custom embroidery
- Storage net
- Waterproof washable protective seat covers

Seat belt options

- Hi-visibility coloured seat belt webbing
- All age seat belts (double all age seat belts)
- Lap seat belts static or inertia reel
- 4 point harnesses
- Occupant activated seat belt buzzers

Standard or custom made seat belts and harnesses can be supplied. For more information or to obtain a quotation please contact us with your requirements.

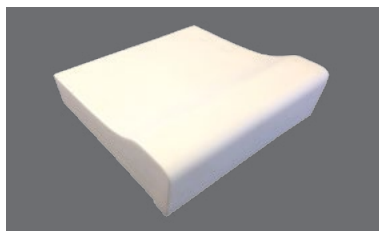
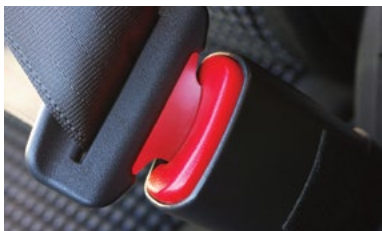

Nationwide Fitting Service

Scot Seats have a nationwide chain of trained and approved fitting agents who can come to your premises to fit most seats. When a Scot Seats approved fitter fits seats you are issued with a certificate of conformity for your insurance company and MOT testing purposes.



We are always keen to expand our chain of approved fitters so if you are a coachworks, garage or vehicle conversion / ply lining specialist contact us to find how to become a Scot Seats approved fitting agent.

Many of our approved fitting agents are also sales agents for Scot Seats who can supply and fit the complete package for you. Visit our website to find your local agent.



Call our sales team on
0845 643 4248
for further information

Seat Testing and Homologation Information

Scot Seats philosophy of Comfort and Safety when YOU need it most is engrained in its heritage. Alex Young, now Chairman, first started manufacturing seats in 1996 and was always focused on the safety of people sitting on his seats. This philosophy has stuck with Scot Seats since then and has made us pioneers in crash testing of vehicle seating with our technical and design team gaining many industry firsts in seat crash testing.

Scot Seats have invested in our own crash test rig to allow quicker product innovation and development and random tests of production seats.

We also work with specialist test centres all over the world including Horiba-Mira, Status, TUV and work closely with VOSA, VCA and TUV type approving seats for M1, M2, M3, N1, N2 and N3 vehicle categories to all relevant ECE Directives. Test certificates and approval documents are readily available from Scot Seats for IVA, NSSTA or ECWVTA vehicle conversions.

Our design and technical team are the only people you need to speak to whatever your seating requirements are.

Directive 2007/46/EC for vehicle category M1:

Regulation ECE R14

Safety-belt anchorages, ISOFIX anchorages systems and ISOFIX top tether anchorages

Regulation ECE R16

Safety-belts, restraint systems, child restraint systems and ISOFIX child restraint systems









Regulation ECE R17













Seat strength

Regulation ECE R21

Interior fittings

Vehicle Category Guide

M1	M2	M3
		
 x 9	 x 21+	 x 22+
 no limit	 5t	 5t+
20G	10G	5G

N1	N2	N3
		
	 	  
 3.5t Max	 12t Max	 12t+



Custom Design, Test and Manufacture

Scot Seats offer a complete design, test and manufacture service for customers' specific requirements from small quantity projects through to high volume production runs.

Our in house capabilities incorporate Solidworks 3d modeling, fabrication (steel, aluminium and stainless steel), wood work / joinery, composite manufacture, metal finishing / coating and upholstery.

The team design seating for OEM, Vehicle Converters, Military, Blue Light Services, Commercial Marine and the Oil & Gas Industry. Whatever your requirements, Scot Seats can help find you a solution.

Being an ISO 90001 approved company, all our products are manufactured to a high standard and work to EU conformity of production procedures.

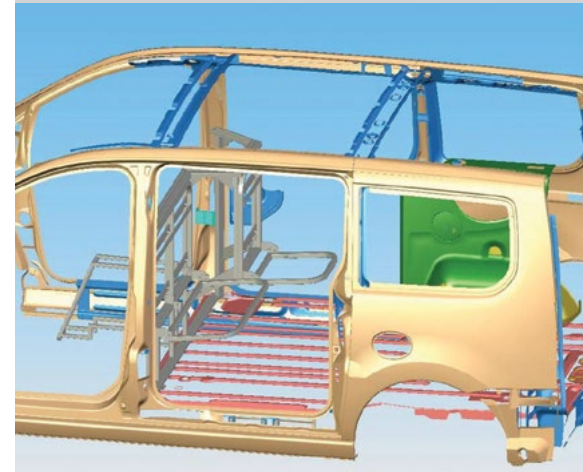
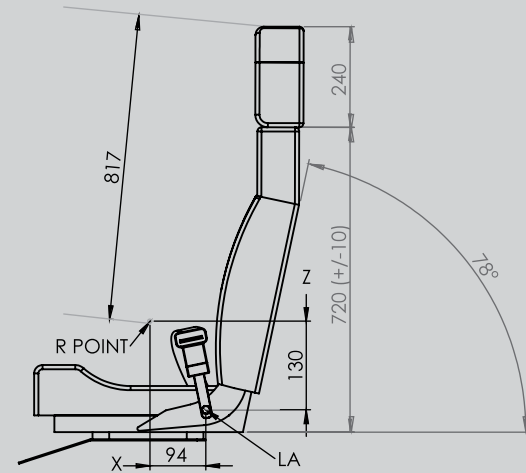





Call our sales team on
0845 643 4248
for further information

Scot Seat Direct Ltd
Gainford Business Centre
Stewarton Road, Fenwick
Ayrshire KA3 6AR

Tel: +44 845 643 4248

Email: sales@scotseats.co.uk

www.scotseats.co.uk

APPROVED AGENT/FITTER:



Scan to visit our website
for more information.



www.facebook.com/scotseats



www.twitter.com/scotseats



www.linkedin.com/company/scot-seat-direct-ltd