

# MB C 2000/150S Transport Platform

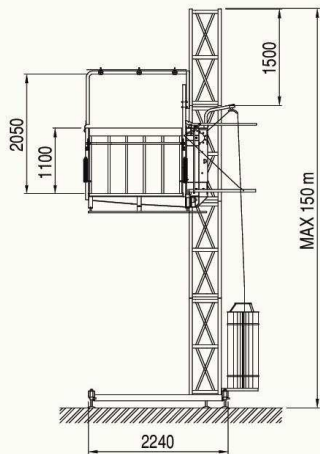

• Unloading ramp with side protections



**TECHNICAL DATA**  
Rated Capacity - 2000kg

**Power Requirements**  
3 Phase - 415 Volt  
32 Amp, 50Hz

Maximum Working Height - 120m  
Max Tie Spacing - 6m

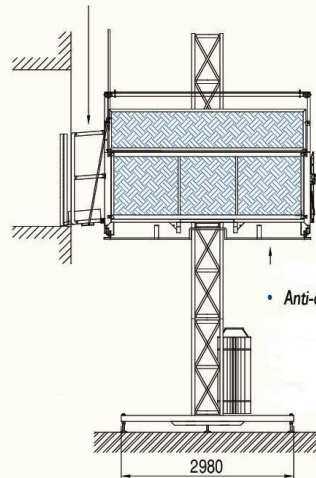

• Anti-crushing grate

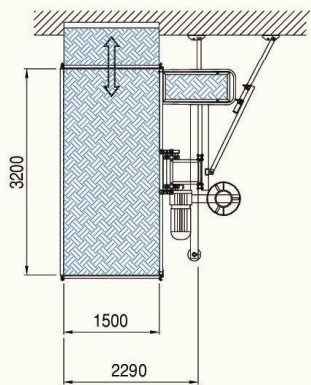

	S	SR
kg	m/min	m/min
2000	24	32

	+1900	12	12
	+1800		
	+1700		
	+1600		
	+1500		
	+1400		
	+1300		
	+1200		

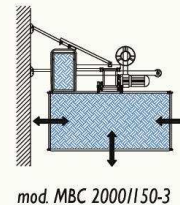
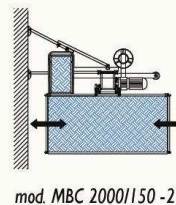

**Plantire Limited**

36 - 38 Feltham Road, Ashford, Middlesex, TW15 1DH

Tel: 01784 247463 Fax: 01784247167 Email: [info@plantire.com](mailto:info@plantire.com) [www.plantire.com](http://www.plantire.com)

Registered in England No. 363180 VAT No. 209 5000 02 Plantire Limited is NQA ISO90002 registered