

*Ecoline 100 RH and
Ecoline 160 LH-
Standard versions
with ' Touch
Applicator'*

Why EcoLine 100/160 ?

Currently one of the most compact, versatile and flexible label applicators on the market:

- **Very easy to use, few buttons**
- **Very compact Swiss design**
- **Clutch less-Stepper motor driven**
- **Variable speed and delay**
- **Various PLC controlled application modules available: tamps and blow**
- **Accepts most types of label stock**
- **Easily integrate able into packaging lines, such as Form Fill Seal etc.**
- **Shaft encoder connection option for continuous web applications**
- **Excellent price /performance ratio**
- **Application Precision +- 0,5 mm**



Speed, Pre-dispensing and Product Delay together with a manual dispense button for ease of use, via the front panel, as well as Status signal indicator for: Start, Stop, Disable, Feed, Power-On and Error.

Other options include: low label alarm, label count, output connection to other systems (e.g. conveyor line stop when error signaled).The clutch less stepper motor drive delivers infinitely variable Labeling speed with precision positioning.

*We give your
Product
Identity*



*Ecoline 100 LH with extended
snorkel applicator option*

Ecoline 100/160
Label path and outer dimensions

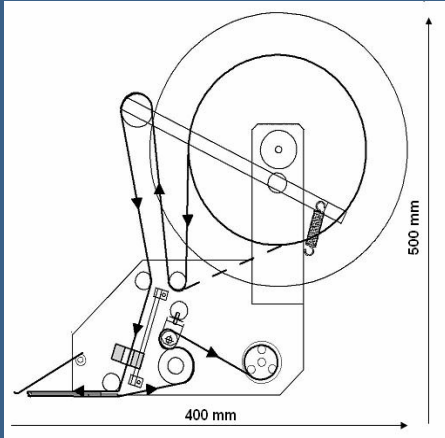

Technical Specifications

	<u>Ecoline 100</u>	<u>Ecoline 160</u>
Maximum label width:	100 mm	160mm
Max. application speed:	25m/min	20m/min
Application precision:	+ - 0,5 mm	+ -0,5 mm
Minimum label length:	10mm	10mm
Minimum label width:	12 mm	12mm
Max Label roll dimensions:	300 mm	300mm
Drive:	Stepper motor 2 phase	
Processing:	Micro processor	
Electrical	115/230V, 50/60Hz	
Power	100VA	
Certification:	CE	
IP rating:	IP44 (optional IP54)	
Connection Options:	NPN and PNP	
Approvals:	CE	

Applicator Options:

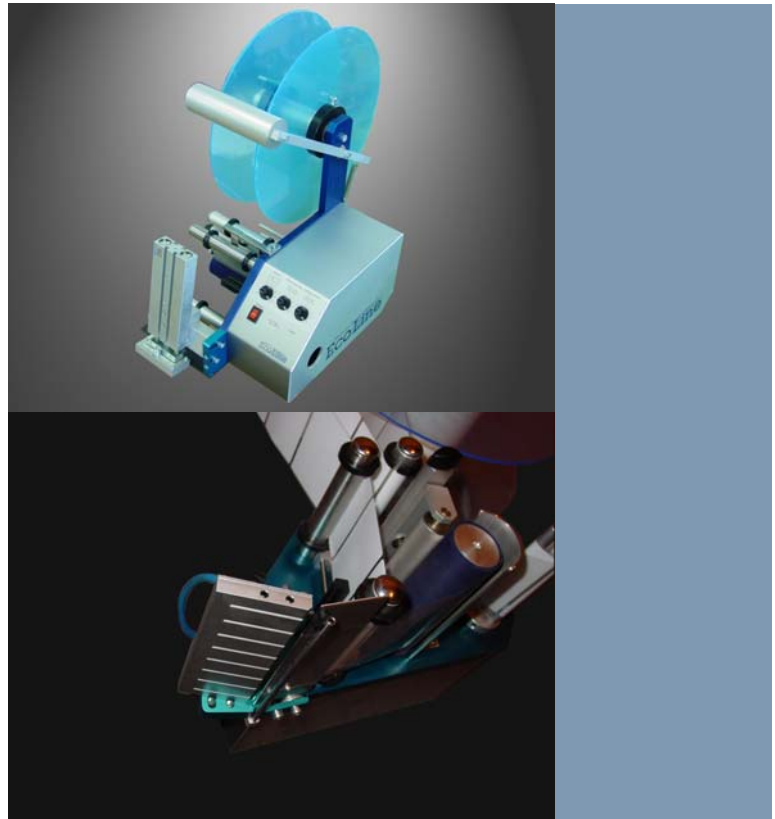

Options:

The following labeling options are available: Blow-, touch- tamp- and swing arm tamp applications, shaft encoder option for continuous web applications

Note: Please call, if you need a labeling solution; applicators or printer –applicators, customized to meet your requirements. Our system specialists have years of experience in the development and integration of labeling and printing systems for most industrial applications