



PackCheck™

Perfect packs, every time!

Detects wrap presence, position and integrity

Detects lid presence

Detects missing or fallen product

Checks tray integrity



Imagine being certain that every pack you produce is complete and properly wrapped

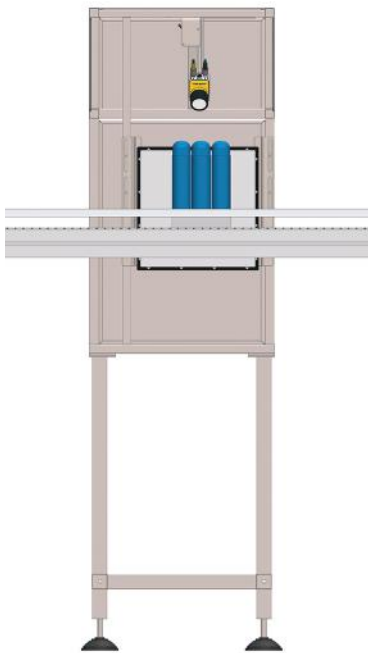

- 100% inspection, zero contact with product
- Easy installation over any conveyor
- No moving parts added to your factory
- Line performance unaffected
- Seamless integration with Smart Factory principles
- Record all reasons for pack rejection
- Prevent jams due to bad wraps
- Ensure pallet stability
- Eliminate customer complaints
- Protect your brand
- Provide peace of mind

Platinum Partner System Integrators for **COGNEX**

CONTACT US TODAY:

www.bytronic.com | +44 1564 793174

PackCheck™ analyses every pack on your production line to ensure that it is complete, with no missing items and that the shrinkwrap has been correctly applied. PackCheck™ can trigger an alarm, reject the faulty pack, or stop production immediately.

PackCheck™'s internal logic can be coded to give a variety of responses based on your operational requirements. If one pack fails you probably just want to reject it, but if 6 in a row fail it looks like a materials issue and you want to stop the line immediately.

PackCheck™ is versatile: it fits any production line, can be powered from any typical source, and is suitable for any pack type regardless of contents, size and wrap type.



Options:

- Barcode validation and grading on pack labels
- Integration with MES/ERP for automatic pack type changeover
- Fixed position or adjustable height, pack height range up to 1000mm
- Standard (check top only) or Advanced (check 4 sides) versions
- Various reject mechanisms available
- Integration with data capture systems (see also LineView™)

Specifications:

- Line speeds: up to 10 packs/second
- Construction: stainless steel
- Input: single phase 900W
- Dimensions: W600xD600mm
- Height: to suit conveyor and pack size
- Pack height tolerance: +/- 50mm
- Vision tech: Cognex VC5/Insight cameras
- Lighting: LED
- PLC: Siemens/Allen-Bradley
- Comms: EthernetIP/Profinet

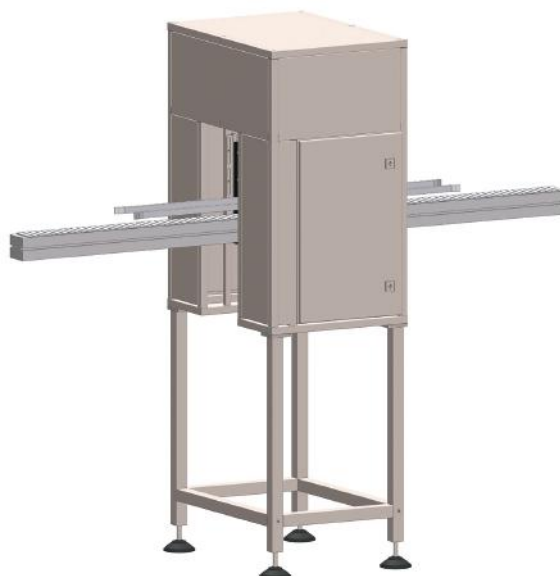

Bytronic
AUTOMATION

Bytronic Automation Ltd
10 Ardent Court
William James Way
Henley-in-Arden
Warwickshire B95 5GF
United Kingdom
T: +44 1564 793174
E: enquiries@bytronic.com
www.bytronic.com

Bytronic **LineView** **OptimumFX.**
AUTOMATION SOLUTIONS CONSULTING

complete manufacturing
improvement
www.i3grp.com