

Cape Cod

Pre-coated
Timber Cladding





Sustainable Forestry

Vincent Timber is at the forefront of the campaign to protect the environment, particularly, the world's forests.

We are members of TRADA who act as our auditors and advisors on all matters relating to the proper implementation of Chain of Custody.

Cape Cod is PEFC certified

Using this system, Vincent Timber is able to supply a wide range of materials which are fully compliant with DEFRA. This covers all legal, sustainable and certification requirements to allow architects to specify with total confidence.



Cape Cod solid wood cladding. Quality from Canada with a 15-year coating warranty*

The Company

Cape Cod Wood Cladding based in Halifax, Nova Scotia is North America's premier manufacturer of pre-finished wood cladding, trims and colour-matched accessories, all manufactured under one roof in a completely controlled environment. By manufacturing wood cladding from a raw piece of wood to a finished product, they can control the quality at each stage of production. It's your assurance of a 100% usable product and one that is pleasing to the eye and environmentally sound.

Cape Cod pre-coated wood cladding is part of family-owned and operated Marwood Ltd, a company that has been supplying the finest quality timber for three generations.



Cape Cod finished wood cladding is natural, beautiful and proven. Cape Cod wood cladding is used by self-builders, developers and

individuals on everything from private to commercial projects.

*Warranty subject to correct installation in accordance with manufacturers' requirements.

CONTENTS

CERTIFICATION	2
THE COMPANY	3
THE TIMBER	4
THE PROCESS	5
COLOURS	6/7
SEMI-TRANSPARENT	8
GALLERY	9
CLADDING PROFILES	10/11
TRIM CORNER	12
INSTALLATION	13
WHY CAPE COD?	14
SUPPLIERS	15

Cape Cod

The Timber

Cape Cod cladding is manufactured from hand selected Canadian Lodgepole Pine which is then kiln dried and band sawn to produce a textured face. Bright and beautifully workable, Lodgepole Pine ranks with the best of the pines.

Soft texture and fine straight grain are key ingredients in Lodgepole Pine's excellent working properties, which are ranked highly among world softwoods. The wood is able to be machined cleanly and evenly to fine tolerances without splitting or splintering.

Lodgepole Pine works well with hand or power tools and takes nails readily and holds them securely. Lodgepole Pine seasons easily with little shrinkage, and when dry, remains dimensionally stable.

Special kiln drying reduces the moisture content of the wood before processing, further enhancing stability. The wood's intergrown knots, a characteristic of the species, are generally small and sound and readily accept and retain the factory applied coating.

The short growing season and relatively slow growth cycle assist in the production of the fine grain and even texture that makes Lodgepole Pine particularly notable for its consistent high quality. And with a timber resource of 1.2 billion cubic metres of mature Lodgepole Pine, the interior forest industry is well positioned to supply and satisfy long-term demand for this practical and versatile wood.



Reducing Carbon Footprint

Using sustainably produced wood contributes towards the lowering of the levels of CO₂ in the atmosphere. Cape Cod is a natural building material, and delivers a positive contribution to carbon neutral construction.

The Controlled Production Process

Raw Timber

We select the finest raw timber, containing only small tight knots with a straight grained texture.



Profiling

We manufacture seven profiles in the range, each with its own characteristic look.



Coating

Cape Cod is coated using a high performance water-based acrylic paint. This is then oven dried and repeated prior to packaging.

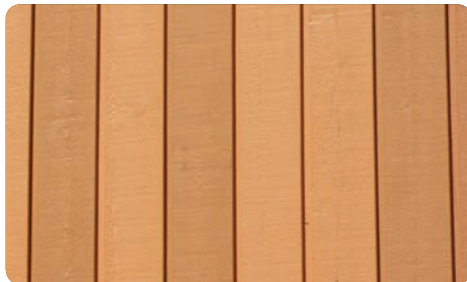

Laboratory

Colour consistency and paint quality is maintained under strict laboratory conditions to match virtually any colour.

Defect Cut / Repair

Our unique 'defect line' ensures that any loose knots are manually removed and the holes are filled to guarantee that 100% usable material is delivered to site.

Colours

Let your imagination go wild

Our designers have selected a wide range of ten standard colours based on current trends and traditional favourites. But if you have something specific in mind, our colour laboratory is fitted with the best technology for capturing your inspiration and ensuring it can be reproduced correctly, every time. This colour match service will give you a colour sample, so you can see exactly how your cladding colour choice will look on your home. The colour lab saves your colour in an archive so your own colour is still available years later.

Our factory applied two-coat process is backed by a 15 year limited warranty against peeling, chalking and blistering and can be available in the colour of your choice.



To view the full custom colour range, please visit the Cape Cod product page on www.vincenttimber.co.uk

For assistance with bespoke/colour match options, please contact the sales team.

Cape Cod SOLID colours



Standard Colours



Arboretum
CCS60001



Cape Cod Grey
CCS20002



Cape Cod White
CCS10006



Chesapeake Blue
CCS8001



Driftwood Grey
CCS2003



Sandalwood
CCS70001



Cape Cod Taupe
CCS70002



Victorian Grey
CCS20024



Cape Cod Black
CCS90010



Vanilla
CCS40005



Custom Colours*

Pastel



Celery Green
CCS60025



Ocean Mist
CCS80010



Desert Loam
CCS40026



Adobe Sand
CCS50017

Strong



Indian Corn
CCS50009



Ocean Blue
CCS80017



Woodland Green
CCS60400



Harvest Gold
CCS40013

Earthy



Cedar
CCS30044



Pewter
CCS20025



New Bark
CCS70385



Russet
CCS70039

*Wider range is available, please request a colour selector card. Visit www.vincenttimber.co.uk
Due to limitations of the printing process, colours may vary. Samples are available prior to order.

Cape Cod SEMITransparent

Standard Colours*



Hickory Smoke
CCS21649



Island Sand
CCS32317



New Forest
CCS72595



Bedford Brown
CCS72599



Annapolis
CCS72597



Cape Cod Cedar
CCS72596

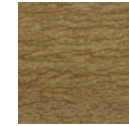

Chalet Brown
CCS72829



Redwood
CCS51406

Hickory Smoke
CCS21649



Cape Cod, with coating partner PPG, has developed a stunning range of SEMITransparent colours. Produced to the same high standard, these claddings provide a more 'natural' look whilst retaining a high performance. The range of colours is available in all profiles and trims, with colour matching nails.

- PEFC certified
- 100% useable
- 8 years warranty
- Natural look
- Attractive colour range
- Treated timber
- Wide range of profiles
- Minimised maintenance
- Factory coated systems

Cape Cod Cedar
CCS72596



* Only available in the 8no standard colours

Please find our Cape Cod profiles on page 10 and 12.

Gallery

To view our extensive range of project images, please visit the Cape Cod gallery pages on www.vincenttimber.co.uk



Cladding Profiles

	Horizontal	Vertical
Rebated Bevel	•	
Rebated Euro Channel	•	•
Rebated Shiplap	•	
Rebated V Joint	•	•
Rhombus	•	•
Double Rhombus	•	•
Board on Board/Batten		•

• = approved use



Rebated Bevel 6

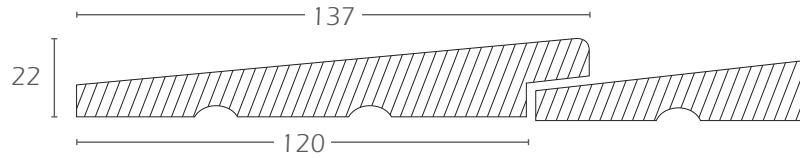

Rebated Bevel 8

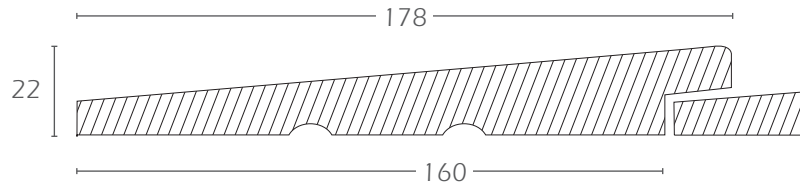

Rebated Euro Channel

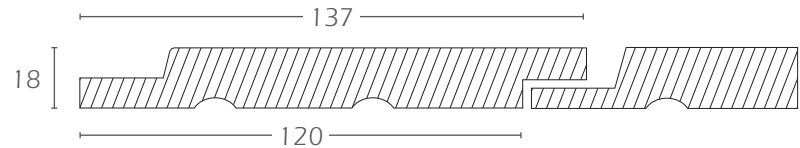

Rebated Shiplap

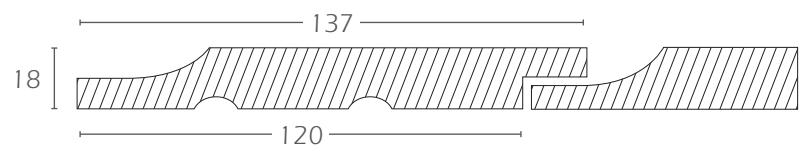

Rebated V-Joint

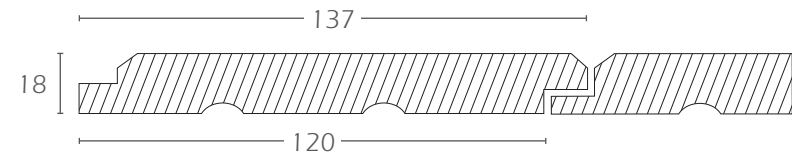

Rhombus

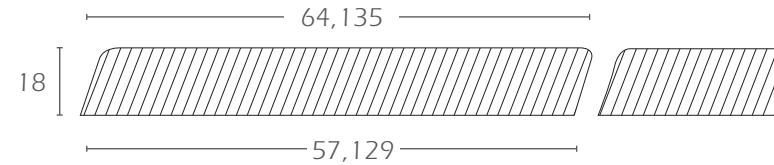

Double Rhombus

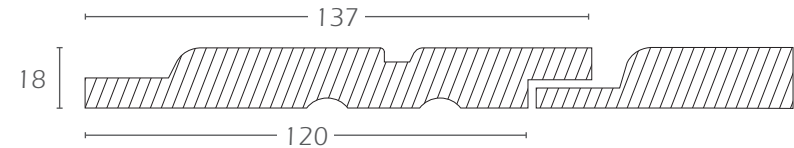

Board on Board/Batten

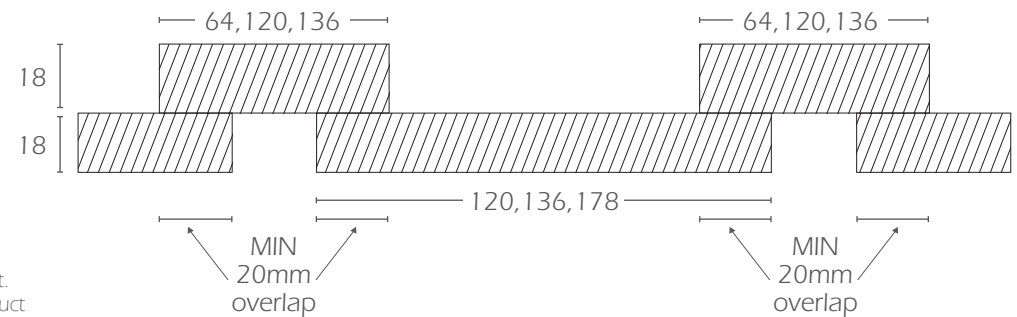

2mm/3mm installation gap is required

Please contact our sales office or your distributor for confirmation of the volumes required for your project. Dimensions may vary due to the hygroscopic nature of timber. Cape Cod reserves the right to alter product dimensions at any time at their discretion.

Trim/Corner Profiles

One Piece External Corner
(35mm x 83mm)

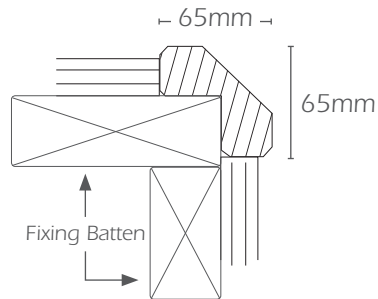

Two Piece Corner
(32mm x 108mm x 32mm x 136mm)

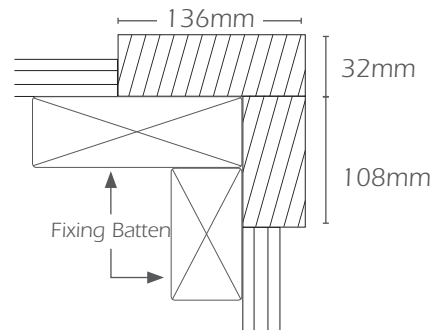

Skirting/Starter Board

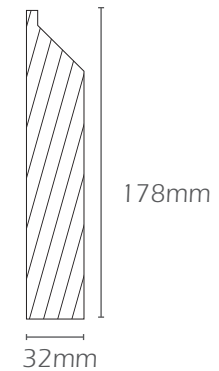

Internal Corner
(35mm x 35mm)

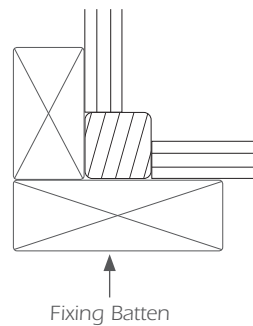

Trims

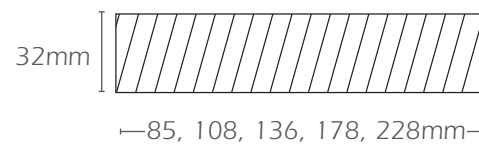
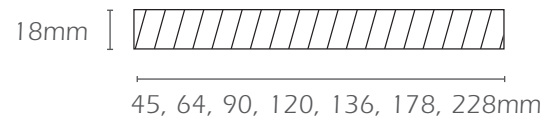

Dimensions may vary due to the hygroscopic nature of timber. Cape Cod reserves the right to alter product dimensions at any time at their discretion.

Installation Tips

1

Cladding and trims should be stored on a flat, level surface, off the ground, preferably under cover where possible. Adequate protection from the elements is essential at all times and must be kept dry prior to installation. The plastic packaging, if opened carefully, can be used for protection.

2

It is imperative that all cuts, particularly ends, are well sealed with matching touch up paint, prior to fixing. Cladding must be fitted tight to junctions with vertical trims and corners. When 'joining' cladding, square butt joints can be used but improved results will be achieved by an angled mitre cut, particularly at top and bottom of boards on vertical applications.

Incorrect

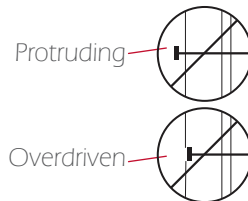

Correction

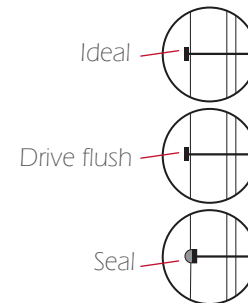

3

Cladding is installed with Cape Cod colour matched stainless steel nails. When using 63mm nails, the cladding can be fitted at maximum 600mm centres. Boards up to 150mm wide can be fitted with a single nail. Boards over 150mm wide require 2 nails per board. Nail heads to be flush with the surface of the cladding (see illustration).

4

Cape Cod requires very little maintenance other than cleaning to remove dirt or algae that may be present. It can be gently hosed down with low pressure if required. Periodic inspection should be carried out for damage or seasoning checks which should be filled and touched up with touch up paint.

Why Cape Cod?

15 good reasons to choose wooden cladding by Cape Cod:

- PEFC certified
- Natural look
- Proven resistance to all weather conditions
- Minimal maintenance
- Attractive standard colour range
- Contributes to carbon neutral construction
- Factory coated system with colour matched nails
- Easy to install, only basic tools required
- Complete system includes fascias, trims and corners
- Colour matching service available from a wide choice
- Coated with high performance PPG machine coat
- Preservative treated timber
- 100% usable
- Wide range of profiles
- 15 YEAR COATING WARRANTY



Suppliers

Vincent Timber is the sole importer of Cape Cod timber cladding for the United Kingdom and Ireland. Crawley Parker Ltd is the South East distributor.

See overleaf for full contact details.

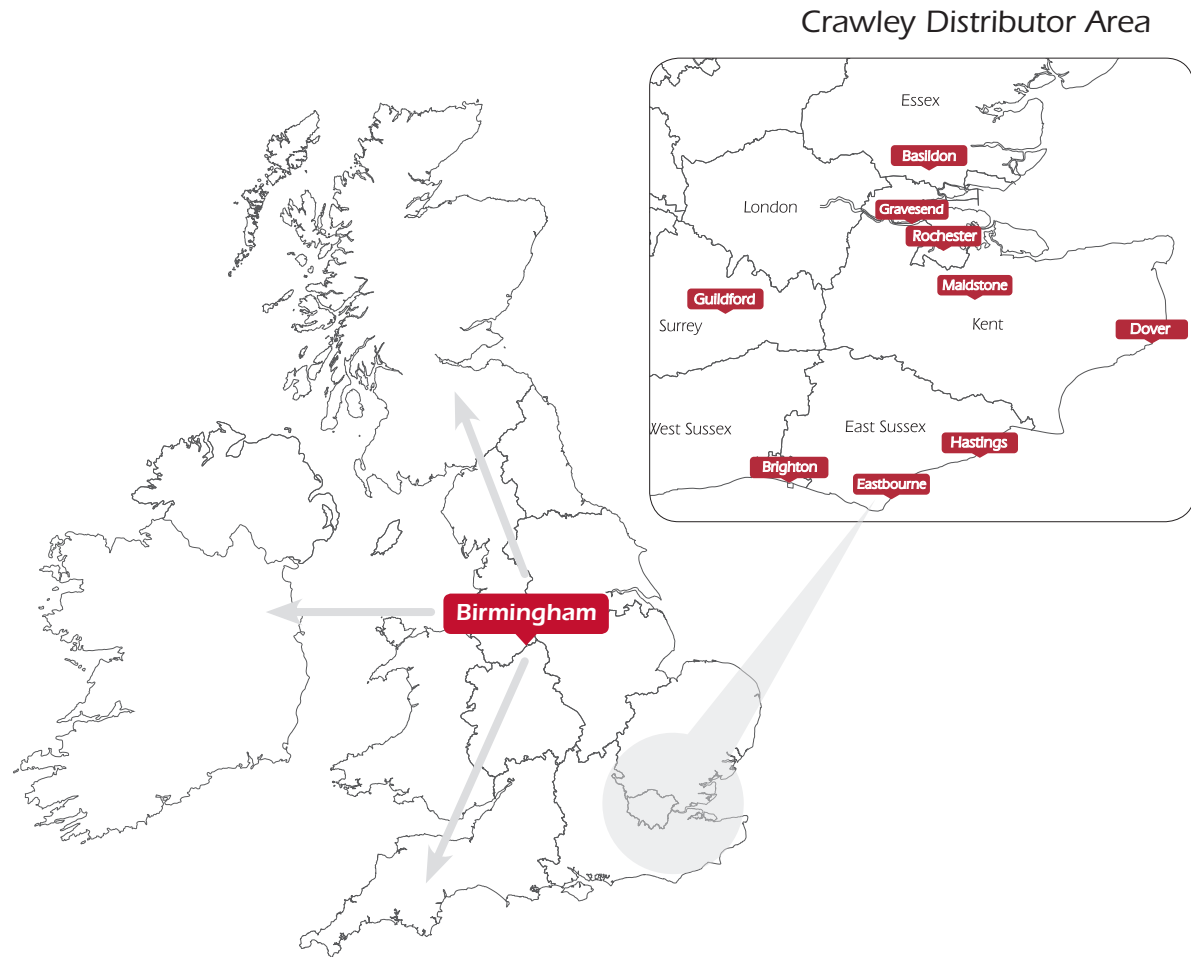

Sole Importer

Vincent Timber Limited

8 Montgomery Street

Birmingham B11 1DU

Telephone:

0121 772 5511

Fax:

0121 766 6002

Email:

capecod@vincenttimber.co.uk

Website:

www.vincenttimber.co.uk



@vincenttimber



South East Distributor

Crawley Parker Ltd

Mulberry Way

Belvedere

Kent

DA17 6AN

Telephone:

020 8311 3420

Fax:

020 8311 2225

Email:

sales@crawleyparker.com

Website:

www.crawleyparker.com

