

# Guide to Assembly & Usage

## Mecalux Pallet Racking Assembly

Read this Guide thoroughly before commencing assembly and retain for future reference. Installation plans and design drawings should be strictly adhered to. Please refer to page 6 for & safety & load Info

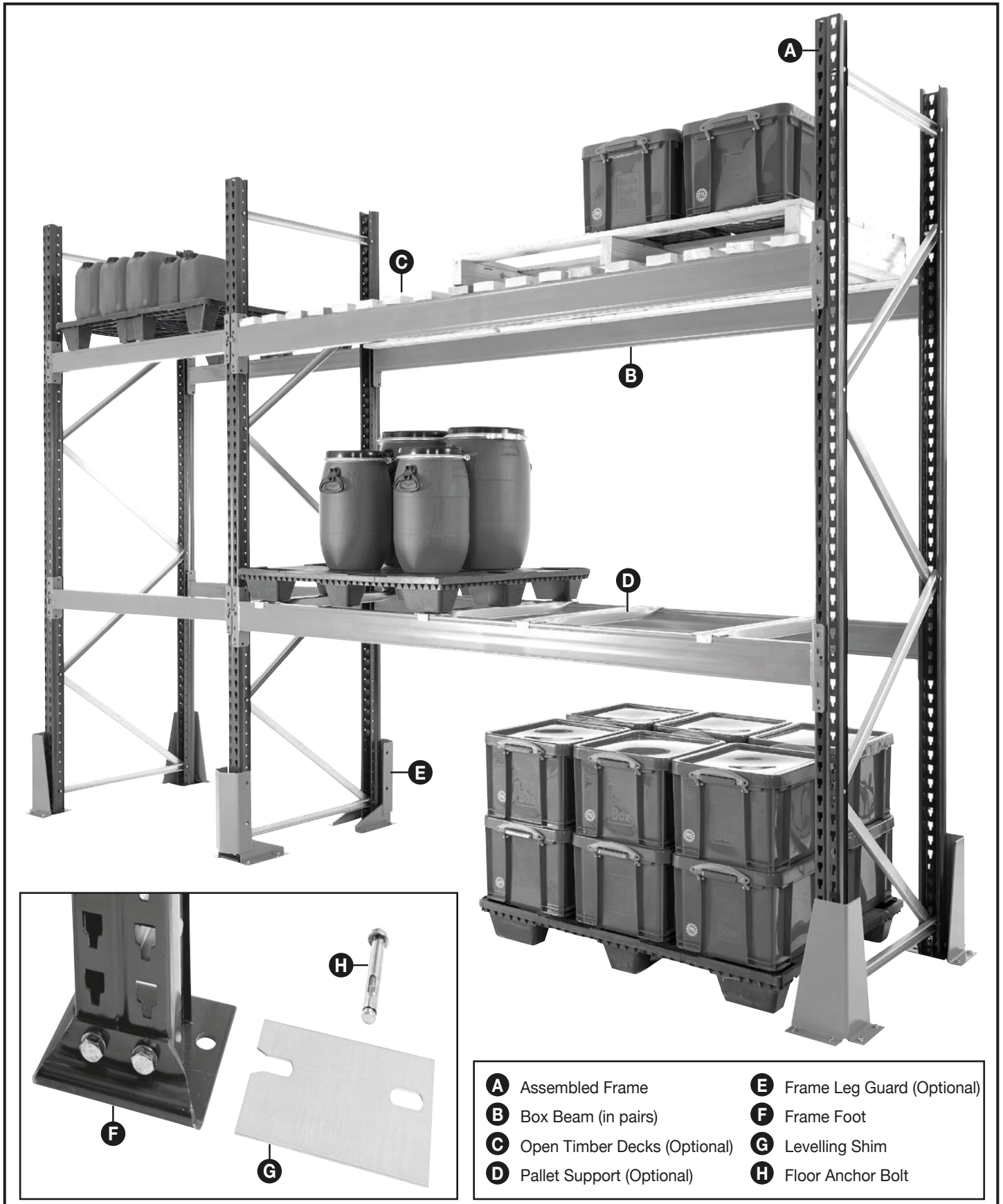

# Assembly – Mecalux Pallet Racking

## Frame Types & Configuration

There are a number of standard frame bracing configurations according to the height of the frames. Please refer to the diagrams below. Ensure that all frames are positioned so that the lowest diagonal bracing nodes are facing into the operating aisle. End frames are normally taller than intermediate frames, so please ensure these are positioned correctly at the ends of each bay run.

- N1** = Single bracing joint with spacer
- N2** = Double bracing joint, no spacer

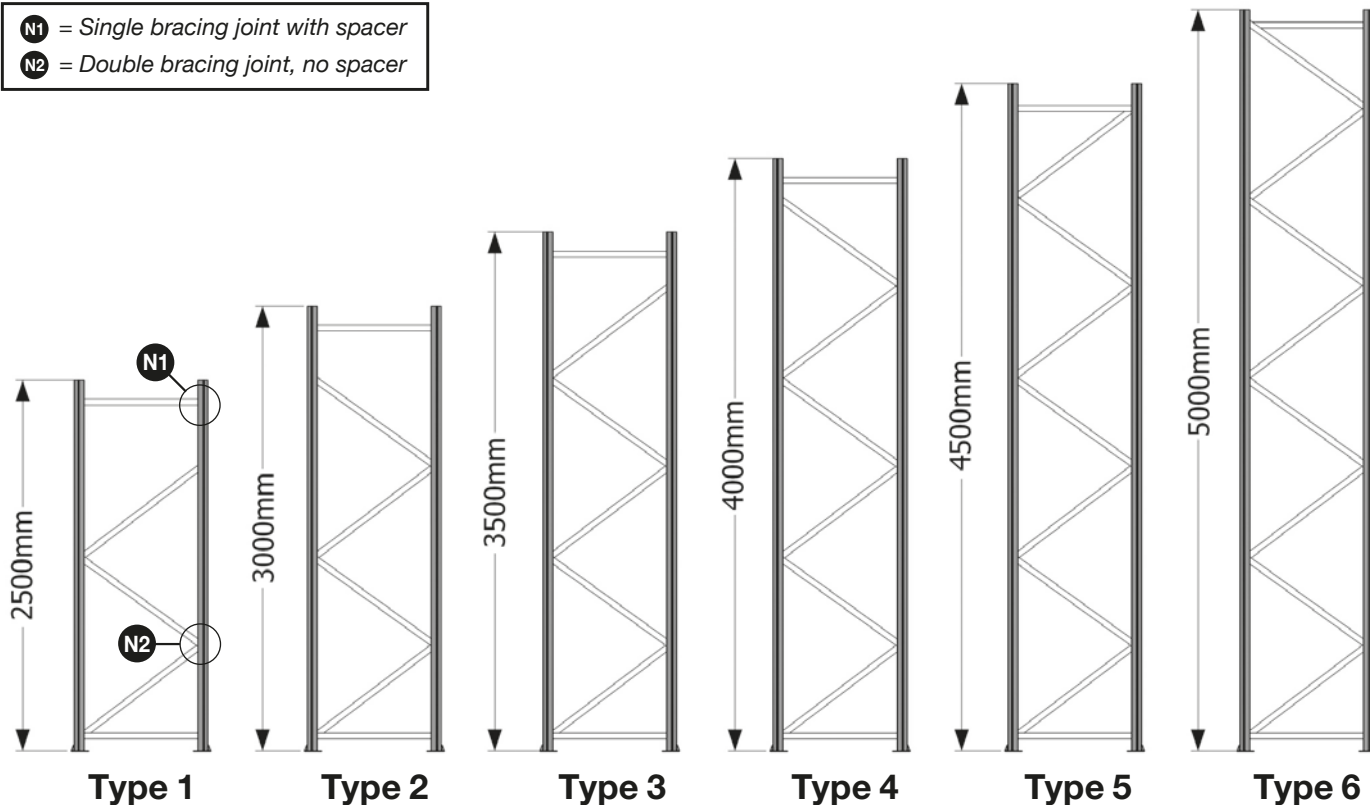

### Frame Positioning (End view)

Lowest diagonal bracing nodes must face into operating aisle

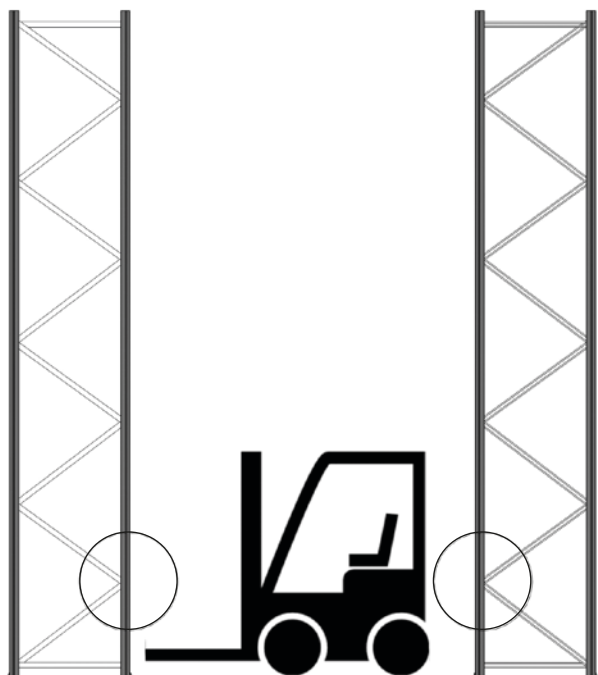

### End Frame Heights (Side view)

End frame should be at least 500mm higher than top beam position. Intermediate frames should be 100mm higher than top beam.

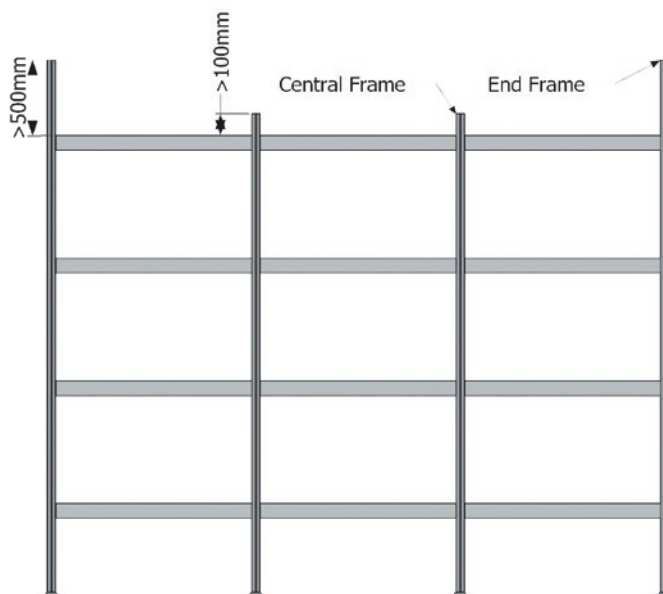

# Assembly – Mecalux Pallet Racking

## Assembly Sequence of Frames and Beams

**IMPORTANT!** Where racking is to be installed or directed to be installed by the end user or an agent acting on their behalf, then bay assembly must be carried out in accordance with the Storage Equipment Manufacturers' Association (SEMA) 'Guide to Method Statements for the Installation of Storage Equipment'. To obtain this guide, refer to page 6 for contact details

**1** Check all components required are on site and not damaged. The area to be racked must be clean and clear of any obstructions. Survey and measure the floor to determine the level, run and aisle positions. Use chalk lines as guides for frame positioning.

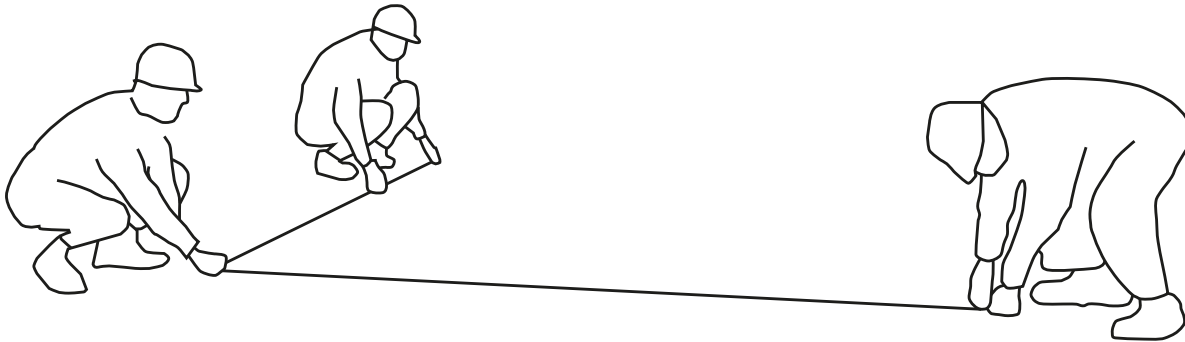

**2** Raise frames and locate beams in compliance with SEMA method statements. Appropriate safety harnesses and lifting equipment must be used. Ensure lowest diagonal bracing nodes are facing into the operating aisle as below:

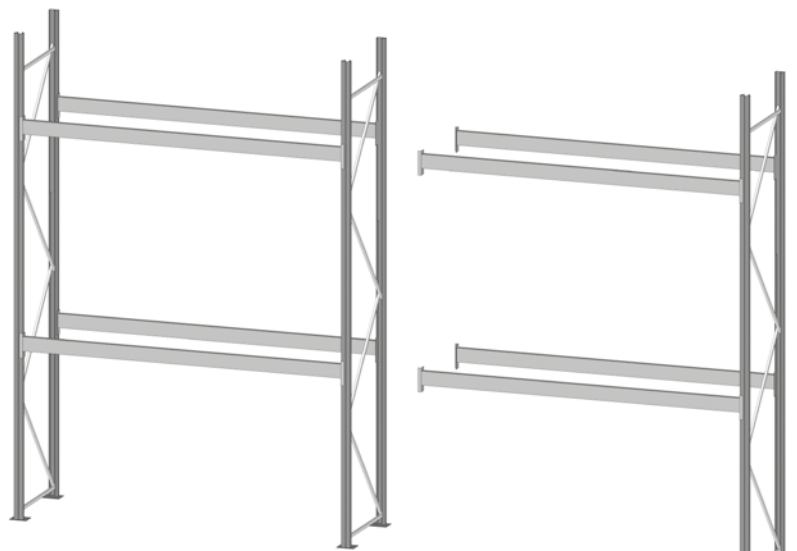
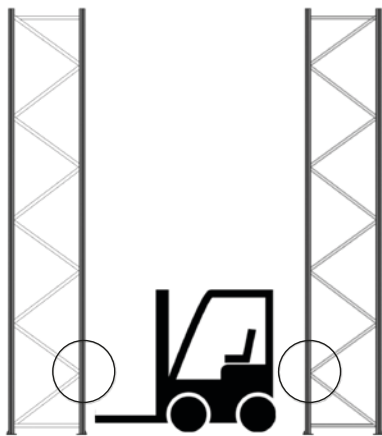

**Starter Bay**

**Extension Bay**

**3** Fit the first beam into the frame by locating the hooked connectors into the perforations on each upright. Ensure the beam is located evenly in both frames and then knock into place with a rubber mallet. Spring loaded safety pin will click down when beam is fully located into upright. Repeat the above steps to fit remaining beams. Access equipment will be required for fitting beams at high levels

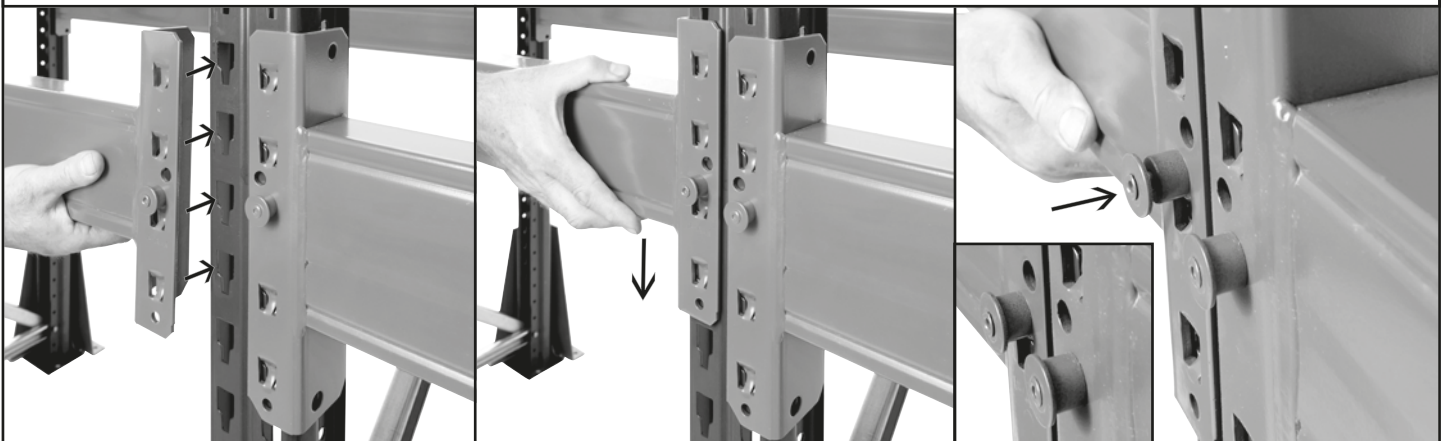

# Assembly – Mecalux Pallet Racking

## 4 Frame Floor Fixing

All foot plates must be fixed to the floor using the required number of M12 x 100mm anchor bolts. Before fixing, check verticals and levels to ensure racking is within recommended tolerances for the installation. Shim as necessary then floor fix. Tighten all bolts to the specified torque loading of 35Nm with a 17mm socket spanner

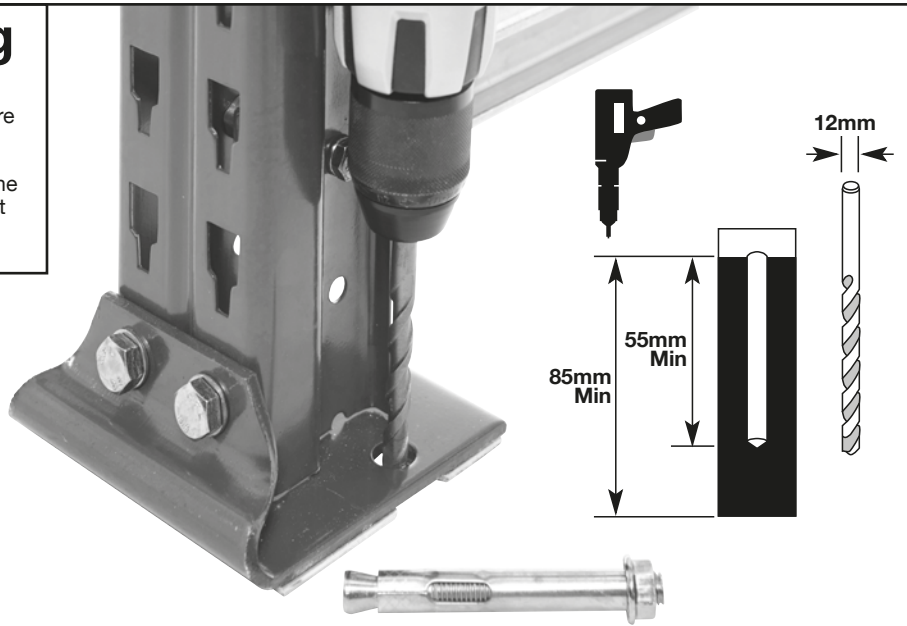
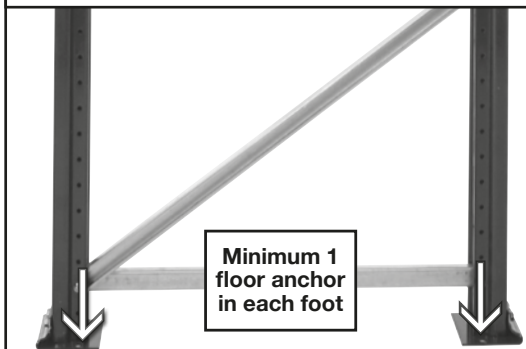

## 5 Row Spacers

Row spacers ensure that the distance between two rows is kept the same. At least 2 spacers should be fitted between each pair of frames, preferably close to the diagonal and horizontal bracing nodes. For frames up to 6m high, use 2 spacers and for frames up to 10m high, use 3 spacers. Row spacers are fitted to the frame uprights with 4x M8 x 25mm bolt and nut sets as shown

Frames Height	Number of Frame Unions
Up to 6000mm	2
Between 6050 - 10000mm	3
From 10050mm	4

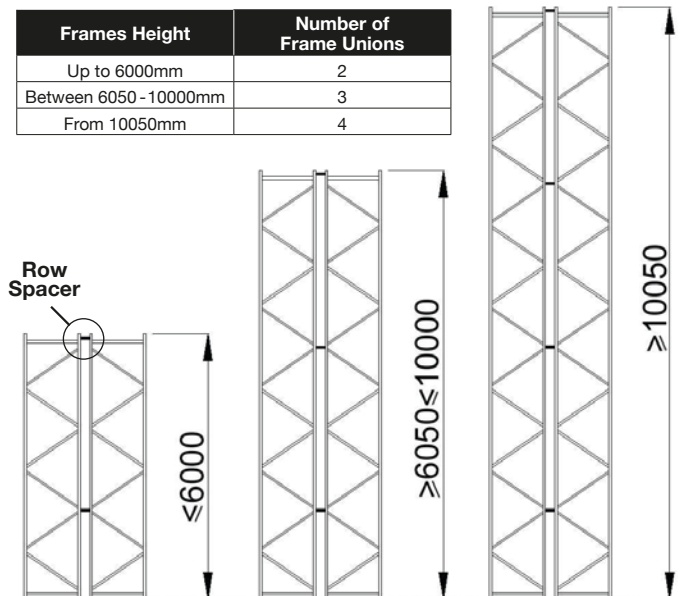

## 6 Frame Protectors

Optional Frame protectors are available in 2 styles – for frame corners and for intermediate legs. Each protector must be bolted to the floor with 4x M12 x 100mm anchor bolts as shown. For optimum frame protection please use the recommended clearances below

Component	Clearance
Corner Protector	60mm
Leg Protector	35mm

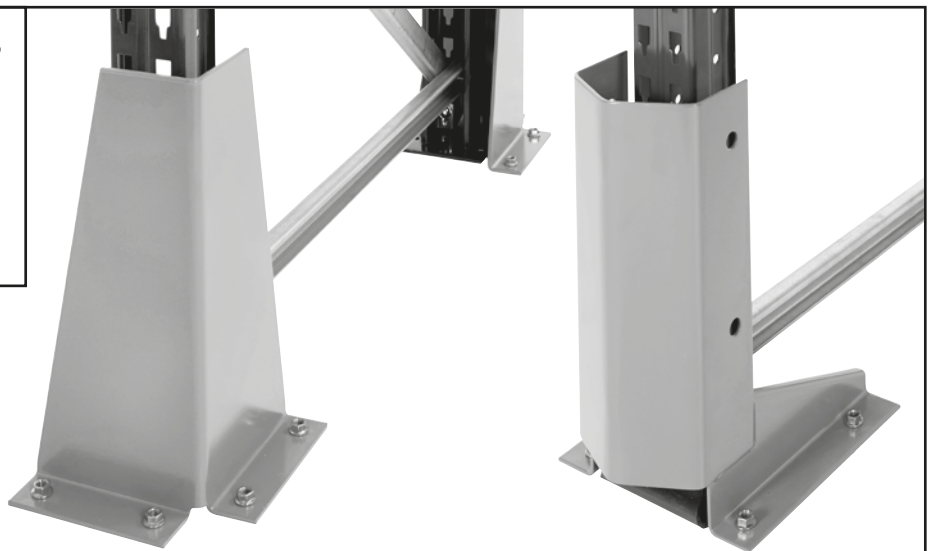

Corner Protector

Leg Protector

# Assembly – Mecalux Pallet Racking

## 7 Pallet Supports

These optional bars can be used as supports for undersize or weak pallets. The number of supports needed will depend on the weight load capacity required. The supports simply sit on top of the beams and are available in 2 standard depths.

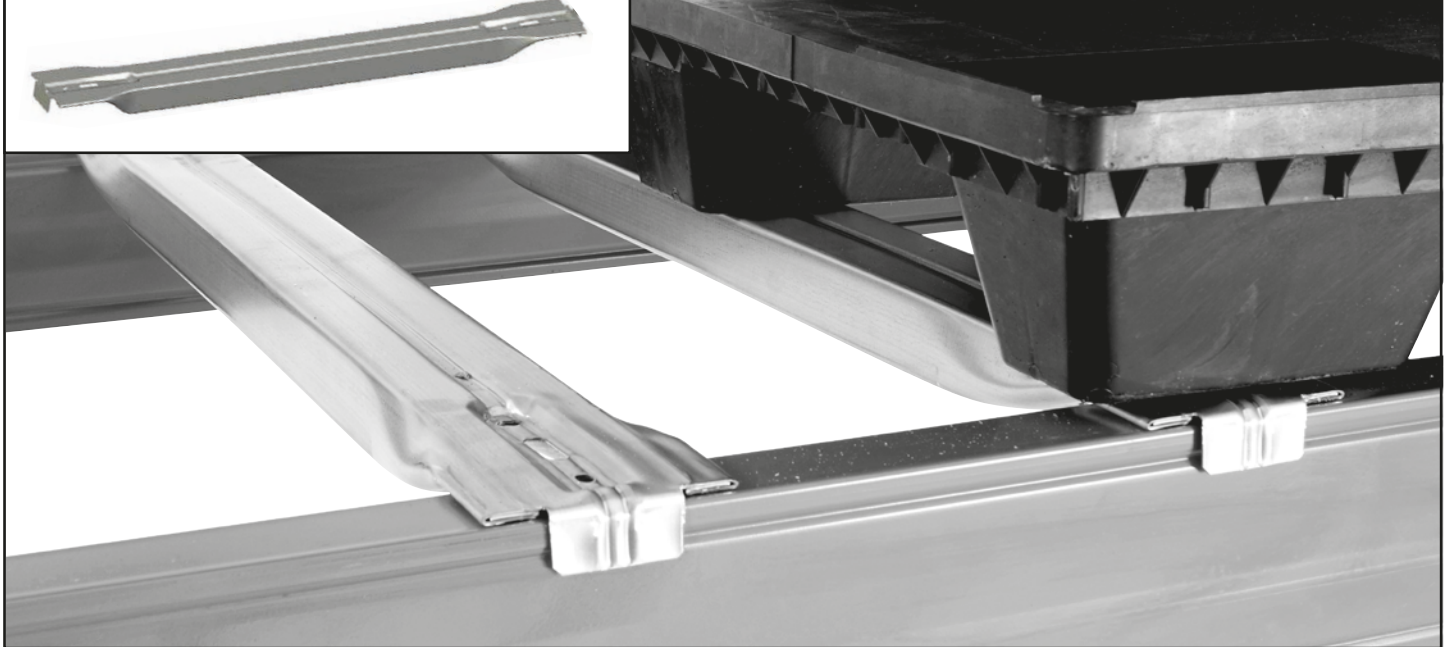

## 8 Loading Charts & Safety Signs

All adjustable pallet racking must display the correct loading information in prominent positions at the end of each run. The exact loading information will vary according to a number of factors including beam type, beam positioning and length. Therefore each run of racking must have a load safety chart containing the correct information as provided by the racking supplier. We also recommend fixing labels to each beam, stating the maximum load per level. Standard templates for load charts are available which can be completed by the end user and positioned as shown. Signs should be located so they can be easily seen and read

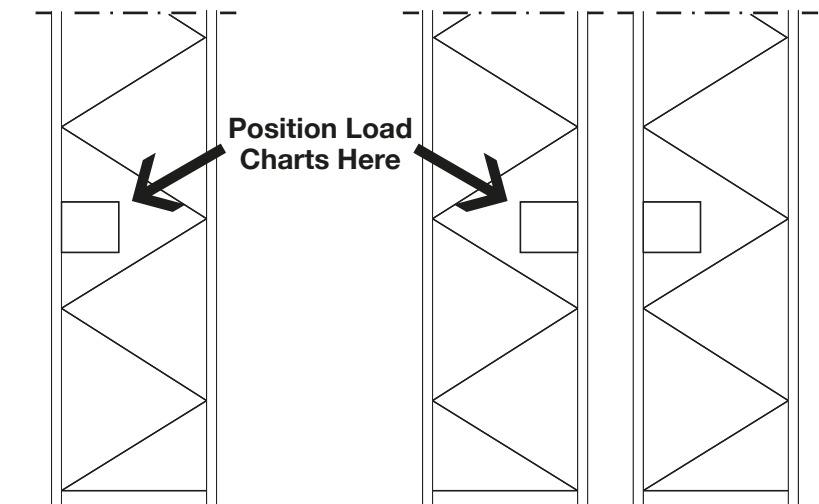

**IMPORTANT!** Any adjustments to beam heights could affect the load capacities of the racking – If in doubt, please check with your racking supplier

### RACKING SAFETY INSPECTION

To comply with current guidelines and workplace health & safety regulations, it is essential that pallet racking is inspected for actual or potential safety hazards. These may be caused by impact damage to the racking or result from missing components. Inspections should be conducted on a regular, scheduled basis by suitably competent personnel. If in doubt about when and how to conduct racking safety inspections, contact your racking supplier

# Assembly – Mecalux Pallet Racking

## Pallet Racking Safety Information

**It is RECOMMENDED that racking installation work is undertaken by experienced, trained personnel ONLY, and under the supervision of SEIRS Registered Installers (SEIRS is the Storage Equipment Installers Registration Scheme, operated by SEMA - see below)**

Where racking is to be installed or directed to be installed by the end user or an agent acting on their behalf, then installation work must be carried out in accordance with the Storage Equipment Manufacturers' Association (SEMA) 'Guide to Method Statements for the Installation of Storage Equipment.'

**This document is available from:**

SEMA, National Metal Forming Centre, 47 Birmingham Road, West Bromwich, B70 6PY

Telephone: +44 (0) 121 6016359

Fax: +44 (0) 121 6016387

E-mail: [enquiry@sema.org.uk](mailto:enquiry@sema.org.uk)

Website: [www.sema.org.uk](http://www.sema.org.uk)

Safety & Load information signs **MUST ALWAYS BE FITTED** and clearly displayed. Loading and performance information should be made available by the racking supplier

Racking **MUST NOT BE DISMANTLED OR THE ADVISED CONFIGURATION CHANGED** without prior consultation with the racking supplier - unauthorized removal or repositioning of beams in particular can seriously compromise the stability and safety of the racking structure.

Unless otherwise stated, load performance information provided assumes **MAXIMUM STATIC UNIFORMLY DISTRIBUTED SAFE WORKING LOADS**. Under no circumstances should quoted capacities be exceeded or varied

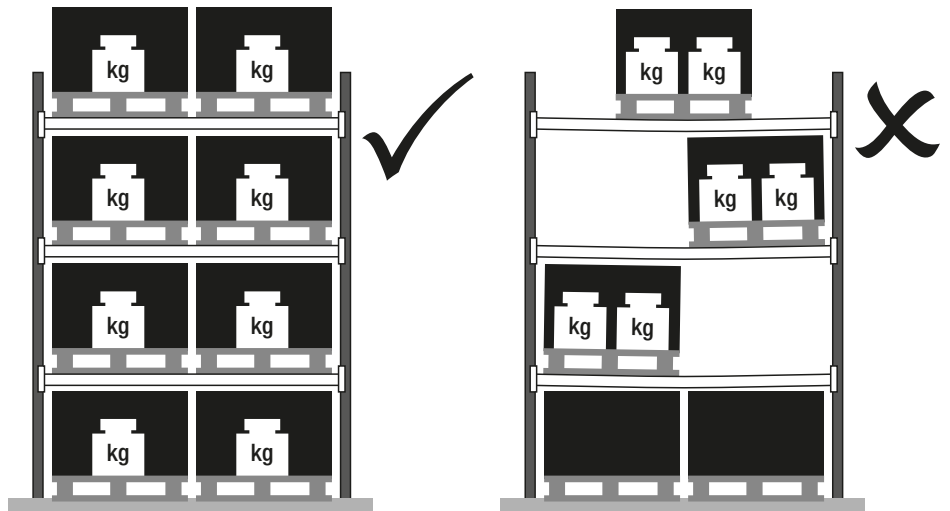

**IMPORTANT!** Pallet Racking must be installed in a combination that is at least 2 bays in length. Single, stand-alone bays and bays with single beam levels are not recommended

During installation, check verticals and levels to ensure the racking is within the recommended parameters, shown right.

The extent of undulation, slopes, steps, ridges, etc. in the concrete floor slab surface affect both racking and handling equipment.

Advice on the effects of floor surface level variations on particular handling equipment should be obtained from the supplier.

The supporting floor slab for pallet racking should be of suitable construction and thickness and level to within 1:1000.

**DO NOT ATTEMPT TO INSTALL PALLET RACKING ON SOFT GROUND, TIMBER FLOORS OR TARMAC SURFACES.**

Note: general parameters only are shown refer to SEMA Guideline No.2 'Guide to Erection Tolerances for Static Racking' for other applications

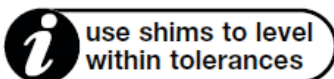
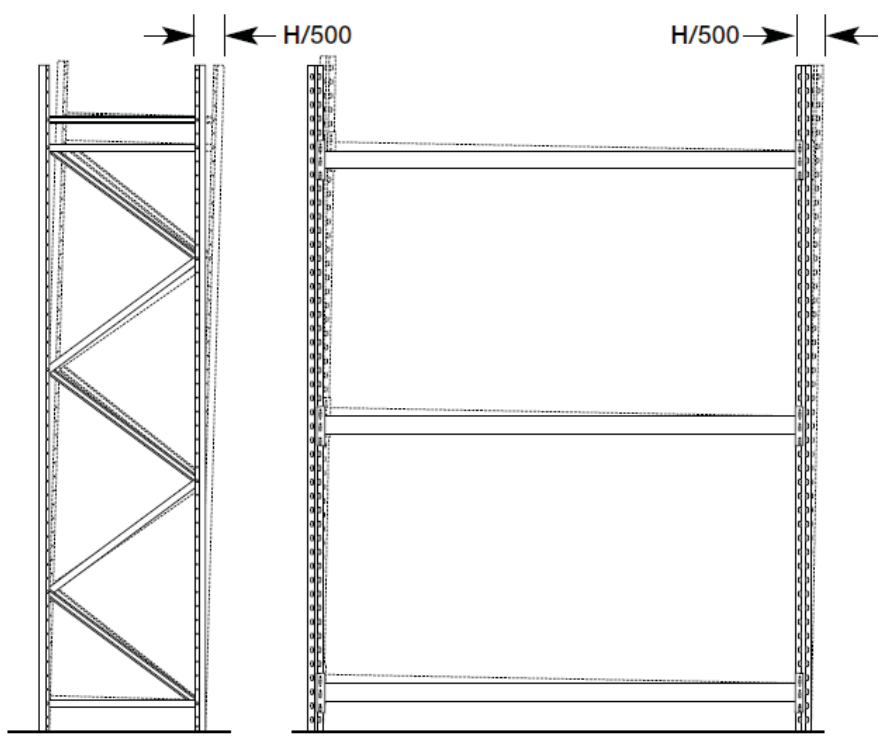

**Installation Tolerances for Standard Adjustable Pallet Racking**