

<b>1</b>	<b>CEILING DISCS AND POSTER PROFILES</b>	<b>1 - 9</b>
	CEILING DISCS	1 - 4
	MAGNETIC CEILING HOOKS	5
	POSTER PROFILES	6 - 8
	MOBILE HANGERS	9

<b>2</b>	<b>SHELF FITTING ACCESSOIRES</b>	<b>10 - 30</b>
	WOBLERS	10 - 14
	SIGN HOLDERS	15 - 17
	COUPON HOLDERS	18
	BANNER HOLDERS	19 - 22
	LABEL HOLDERS	23 - 25
	HANG-STRIPS	26 - 29
	PUSHERS AND SHELF DIVIDERS	30

<b>3</b>	<b>TICKET ACCESSORIES</b>	<b>31 - 59</b>
	ATTACHMENTS	31 - 34
	CARD HOLDERS	35 - 46
	TICKET HOLDERS	47 - 53
	SUCTION CUPS	54 - 56
	BADGE ACCESSORIES	57 - 59

<b>4</b>	<b>LEAFLET DISPENSERS</b>	<b>60 - 68</b>
	LEAFLET DISPENSERS	60 - 64
	LEAFLET HOLDERS	65 - 66
	POCKETS	67 - 68

<b>5</b>	<b>DISPLAY ACCESSORIES</b>	<b>69 - 81</b>
	DISPLAY ARMS AND ACCESSORIES	69 - 74
	HANG TABS	75
	FLAG ACCESSORIES	76
	POLE ACCESSORIES	77
	TURNTABLES	78
	DISPLAY CONSTRUCTION	79 - 81

<b>6</b>	<b>PRINTING ACCESSORIES</b>	<b>82 - 97</b>
	RIVETS	82 - 84
	HOOKS AND LOOPS	85
	TAPE AND MAGNETIC TAPE	86 - 89
	DOCUMENT HOLDERS	90
	CD-ACCESSORIES	91 - 92
	CHAINS	93 - 94
	RINGS AND HOOKS	95 - 97

<b>7</b>	<b>FRAMES</b>	<b>98 - 110</b>
	SNAP FRAMES	98 - 100
	ALUMINIUM SHOWCARD STANDS	101
	PLASTIC SHOWCARD STANDS AND ACCESSORIES	102 - 104
	PAVEMENT SIGNS	105 - 106
	BANNER DISPLAYS	107 - 108
	SHOP-WINDOW PRESENTATION	109 - 110

<b>8</b>	<b>MISCELLANEOUS</b>	<b>111 - 116</b>
	SECURITY SYSTEMS	111
	HANDLES	112 - 114
	CALENDAR ACCESSORIES	115 - 116



604-047

P. 7



604-048

P. 8



605-026

P. 11



605-068

P. 11



605-164

P. 14



605-165

P. 14



603-069

P. 16



603-070

P. 17



605-027

P. 19

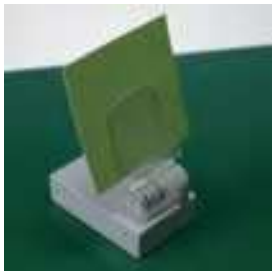

608-115

P. 20



605-069

P. 25



605-070

P. 25



605-071

P. 25



601-367

P. 26



612-008 - 612-011

P. 30

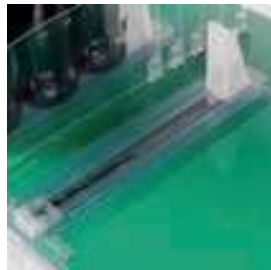

612-003

P. 30



612-004

P. 30

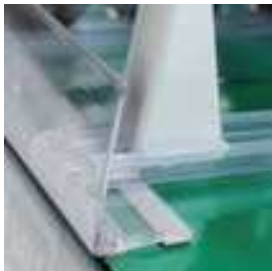

612-005 - 612-013

P. 30



612-006 - 612-009

P. 30



200-020

P. 34



NEW

NEW

NEW

NEW

NEW

NEW

NEW

603-066

P. 35



603-067

P. 38



603-068

P. 38



601-118

P. 41



603-108

P. 42



603-063

P. 43

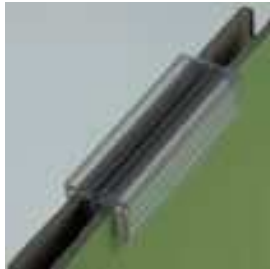

603-064

P. 45



603-065

P. 45



603-072

P. 46



602-030

P. 56



602-028

P. 56



602-029

P. 56



611-217

P. 59



607-082

P. 63



604-028

P. 63



606-196

P. 64



601-360

P. 72



601-368

P. 73



601-369

P. 73



604-080

P. 77



NEW

NEW

NEW

NEW

NEW

NEW

NEW

NEW

NEW

NEW

NEW

NEW

NEW

NEW

609-014

P. 80

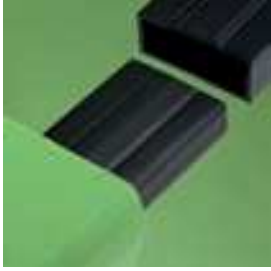

609-005

P. 80



609-010

P. 80



609-011

P. 80



609-013

P. 80



609-017

P. 81



609-006

P. 81



609-007

P. 81



609-008

P. 81



611-255

P. 88



604-008 - ...

P. 97



609-009

P. 97



608-117 - ...

P. 98



608-130 - ...

P. 99



608-133 - ...

P. 100



606-200 - ...

P. 101



607-081

P. 103



607-085

P. 106



607-084

P. 106



608-102 - 608-101

P. 107



608-107 - 608-106

P. 107



608-116

P. 108



NEW

NEW

NEW

NEW

NEW

NEW

NEW



**TO LOCATE YOUR CHOSEN ITEM, FOLLOW THE PAGE NUMBER INDICATED IN THE BOTTOM RIGHT HAND CORNER OF EACH FRAME.**

**CEILING DISCS AND POSTER PROFILES**

**CEILING DISCS**

602-003    602-001    603-019



602-008    602-009    602-002



**P. 1**

**CEILING DISCS AND POSTER PROFILES**

**CEILING DISCS**

602-088    602-057    604-011



602-007    602-089

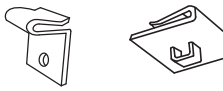

**P. 2**

**CEILING DISCS AND POSTER PROFILES**

**CEILING DISCS**

602-044    602-045    602-004



602-046    602-047

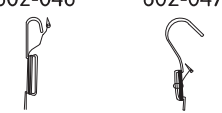

**P. 3**

**CEILING DISCS AND POSTER PROFILES**

**CEILING DISCS**

602-048 - ...    602-043    602-014 - ...



602-100 - ...    601-169



**P. 4**

**CEILING DISCS AND POSTER PROFILES**

**MAGNETIC CEILING HOOKS**

602-026    602-027    611-266

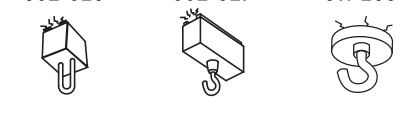

602-128    611-265



**P. 5**

**CEILING DISCS AND POSTER PROFILES**

**POSTER PROFILES**

604-003    604-042 - ...    604-001

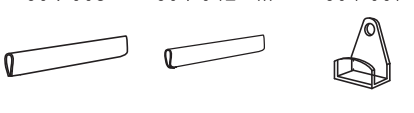

604-004

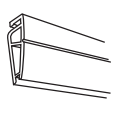

**P. 6**

**CEILING DISCS AND POSTER PROFILES**

**POSTER PROFILES**

604-002    604-078    604-079

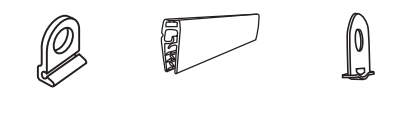

604-047

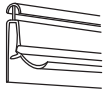

**P. 7**

**CEILING DISCS AND POSTER PROFILES**

**POSTER PROFILES**

604-048    604-025 - ...    604-029 - ...

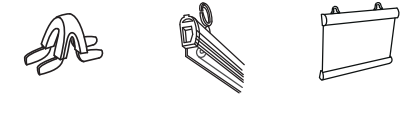

604-060 - ...

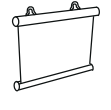

**P. 8**

**CEILING DISCS AND POSTER PROFILES**

**MOBILE HANGERS**

602-201    602-200    602-202

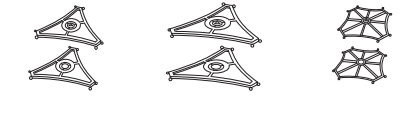

602-043

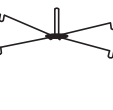

**P. 9**

**SHELF FITTING ACCESSORIES**

**WOBBLERS**

605-007 - 605-005    605-161    605-162



605-163    605-166

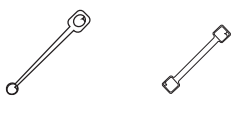

**P. 10**

**SHELF FITTING ACCESSORIES**

**WOBBLERS**

605-067    605-048    605-010 - 605-058



605-026    605-068

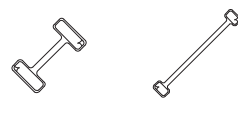

**P. 11**

**SHELF FITTING ACCESSORIES**

**WOBBLERS**

605-066    605-011    605-137

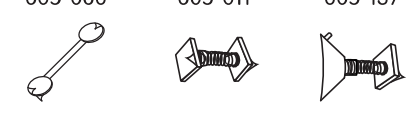

605-145 - 605-173    605-012 - 605-174

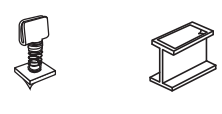

**P. 12**

**TO LOCATE YOUR CHOSEN ITEM, FOLLOW THE PAGE NUMBER INDICATED  
IN THE BOTTOM RIGHT HAND CORNER OF EACH FRAME.**

**SHELF FITTING ACCESSORIES**

**WOBBLERS**

605-168    605-169    605-170

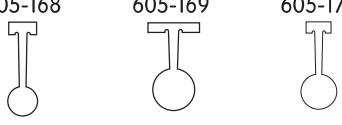

605-171    605-160

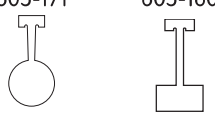

**P. 13**

**SHELF FITTING ACCESSORIES**

**WOBBLERS**

605-164



605-165



**P. 14**

**SHELF FITTING ACCESSORIES**

**SIGN HOLDERS**

603-002    603-055    603-038



603-001 - 603-071



**P. 15**

**SHELF FITTING ACCESSORIES**

**SIGN HOLDERS**

X15    602-055    602-056



603-069



**P. 16**

**SHELF FITTING ACCESSORIES**

**SIGN HOLDERS**

603-070    603-016 - 603-049    603-037

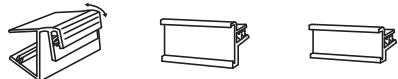

603-039



**P. 17**

**SHELF FITTING ACCESSORIES**

**COUPON HOLDERS**

605-134 - ...    605-172 - ...    605-112



605-130    605-122



**P. 18**

**SHELF FITTING ACCESSORIES**

**BANNER HOLDERS**

608-023    608-021    605-027



608-001    608-002

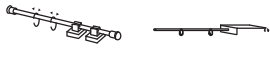

**P. 19**

**SHELF FITTING ACCESSORIES**

**BANNER HOLDERS**

608-003    608-004    608-115



604-035    604-036



**P. 20**

**SHELF FITTING ACCESSORIES**

**BANNER HOLDERS**

604-018    604-019    604-020

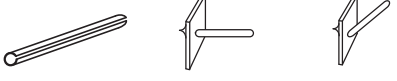

604-021    604-022



**P. 21**

**SHELF FITTING ACCESSORIES**

**BANNER HOLDERS**

605-127    605-129    605-130



605-131

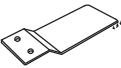

**P. 22**

**SHELF FITTING ACCESSORIES**

**LABEL HOLDERS**

605-035 - ...    605-102    605-036

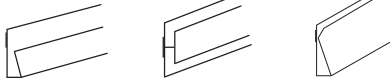

605-019 - ...    605-143 - ...

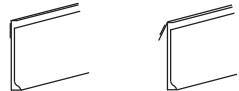

**P. 23**

**SHELF FITTING ACCESSORIES**

**LABEL HOLDERS**

605-038 - ...    605-106 - ...    605-100 - ...



605-101



**P. 24**

**TO LOCATE YOUR CHOSEN ITEM, FOLLOW THE PAGE NUMBER INDICATED  
IN THE BOTTOM RIGHT HAND CORNER OF EACH FRAME.**

**SHELF FITTING ACCESSORIES**

**LABEL HOLDERS**

605-043    605-069    605-070

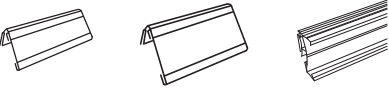

605-071



**P. 25**

**SHELF FITTING ACCESSORIES**

**HANG-STRIPS**

601-134    601-132 - 601-133    601-367

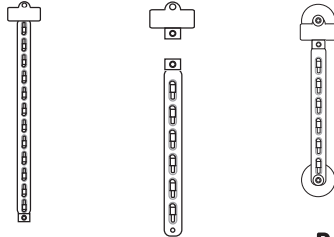

**P. 26**

**SHELF FITTING ACCESSORIES**

**HANG-STRIPS**

601-234    601-237    601-127

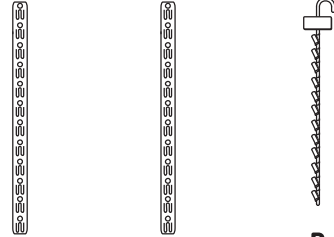

**P. 27**

**SHELF FITTING ACCESSORIES**

**HANG-STRIPS**

601-338    601-140    601-100

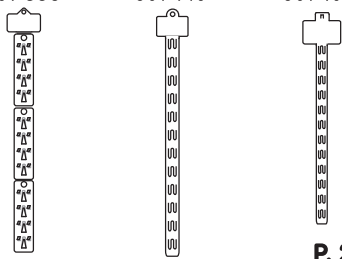

**P. 28**

**SHELF FITTING ACCESSORIES**

**HANG-STRIPS**

601-128    601-170 - 601-232    601-254

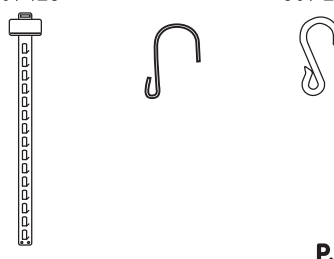

**P. 29**

**SHELF FITTING ACCESSORIES**

**PUSHERS AND SHELF DIVIDERS**

612-008 - 612-011    612-003    612-004



612-005 - 612-013    612-006 - 612-009

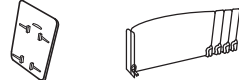

**P. 30**

**TICKET ACCESSORIES**

**ATTACHMENTS**

200-038 - ...    200-041 - ...    200-047 - ...



200-049



**P. 31**

**TICKET ACCESSORIES**

**ATTACHMENTS**

200-050    200-017 - 200-019    611-078 - ...



200-002 - ...



**P. 32**

**TICKET ACCESSORIES**

**ATTACHMENTS**

200-014    200-036    200-009 - ...

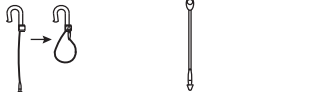

200-034 - ...



**P. 33**

**TICKET ACCESSORIES**

**ATTACHMENTS**

200-020    611-074    611-061

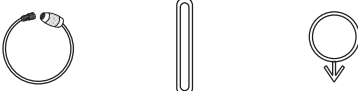

605-133    611-242



**P. 34**

**TICKET ACCESSORIES**

**CARD HOLDERS**

603-045 - ...    603-066    603-054



603-005 - ...    603-048



**P. 35**

**TICKET ACCESSORIES**

**CARD HOLDERS**

603-100 - ...    603-102 - ...    605-013 - ...

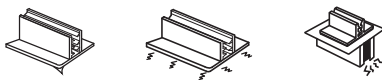

603-007 - ...    603-043

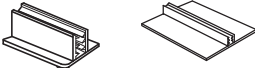

**P. 36**

**TO LOCATE YOUR CHOSEN ITEM, FOLLOW THE PAGE NUMBER INDICATED  
IN THE BOTTOM RIGHT HAND CORNER OF EACH FRAME.**

**TICKET ACCESSORIES**

**CARD HOLDERS**

603-058    603-046    603-047

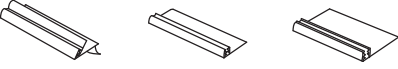

603-060    603-059 - ...

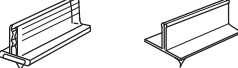

**P. 37**

**TICKET ACCESSORIES**

**CARD HOLDERS**

603-067    603-009 - ...    603-012 - ...

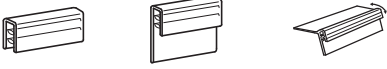

603-068    603-014



**P. 38**

**TICKET ACCESSORIES**

**CARD HOLDERS**

603-015    603-050    603-035



602-012    603-057



**P. 39**

**TICKET ACCESSORIES**

**CARD HOLDERS**

602-006    602-062    611-235



611-233    611-234



**P. 40**

**TICKET ACCESSORIES**

**CARD HOLDERS**

601-118    603-103    603-017



603-018



**P. 41**

**TICKET ACCESSORIES**

**CARD HOLDERS**

603-021    603-022    603-024



603-034    603-108



**P. 42**

**TICKET ACCESSORIES**

**CARD HOLDERS**

603-040    603-063    603-025

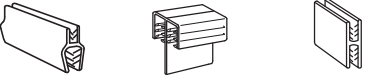

603-101    603-026



**P. 43**

**TICKET ACCESSORIES**

**CARD HOLDERS**

603-027    603-028    603-029

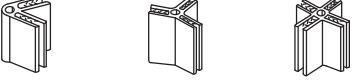

603-041    603-030



**P. 44**

**TICKET ACCESSORIES**

**CARD HOLDERS**

603-031    603-064    603-065

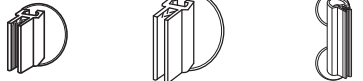

603-042    603-032



**P. 45**

**TICKET ACCESSORIES**

**CARD HOLDERS**

603-033    603-072    603-044



605-014



**P. 46**

**TICKET ACCESSORIES**

**TICKET HOLDERS**

605-158    605-042    605-159

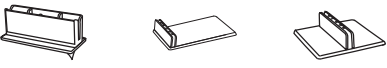

603-051    603-052 - ...



**P. 47**

**TICKET ACCESSORIES**

**TICKET HOLDERS**

603-061    605-132    605-031



605-024    605-030



**P. 48**



**TO LOCATE YOUR CHOSEN ITEM, FOLLOW THE PAGE NUMBER INDICATED IN THE BOTTOM RIGHT HAND CORNER OF EACH FRAME.**

**TICKET ACCESSORIES**

**TICKET HOLDERS**

605-045    605-028    605-029



605-140    605-146

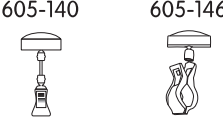

**P. 49**

**TICKET ACCESSORIES**

**TICKET HOLDERS**

605-147    605-049    605-148



605-149    605-150

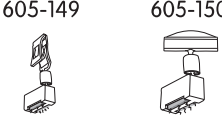

**P. 50**

**TICKET ACCESSORIES**

**TICKET HOLDERS**

605-050    605-051    605-052



605-111    611-081

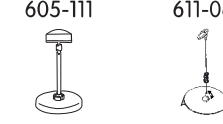

**P. 51**

**TICKET ACCESSORIES**

**TICKET HOLDERS**

605-151    605-152    605-153



**P. 52**

**TICKET ACCESSORIES**

**TICKET HOLDERS**

605-154    605-155    605-156

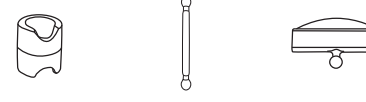

605-157

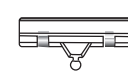

**P. 53**

**TICKET ACCESSORIES**

**SUCTION CUPS**

602-010    602-011    602-024

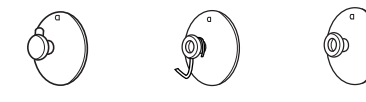

602-022    602-054

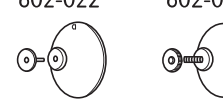

**P. 54**

**TICKET ACCESSORIES**

**SUCTION CUPS**

602-019    602-023    602-091



602-032    602-031

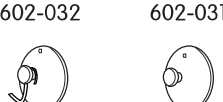

**P. 55**

**TICKET ACCESSORIES**

**SUCTION CUPS**

602-030    602-028    602-108

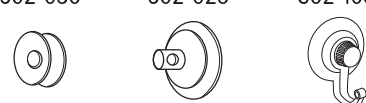

602-029



**P. 56**

**TICKET ACCESSORIES**

**BADGE ACCESSORIES**

611-115    611-116    611-117



611-118    611-119

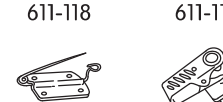

**P. 57**

**TICKET ACCESSORIES**

**BADGE ACCESSORIES**

611-164    611-012    611-223



611-224    611-121



**P. 58**

**TICKET ACCESSORIES**

**BADGE ACCESSORIES**

611-217    602-085    611-122



611-165    611-127 - ...



**P. 59**

**TICKET ACCESSORIES**

**LEAFLET DISPENSERS**

606-304 - ...    606-144    606-147



606-148    606-174



**P. 60**

**TO LOCATE YOUR CHOSEN ITEM, FOLLOW THE PAGE NUMBER INDICATED IN THE BOTTOM RIGHT HAND CORNER OF EACH FRAME.**

**LEAFLET DISPENSERS**

**LEAFLET DISPENSERS**

606-149    606-150    606-151

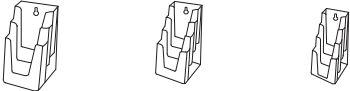

606-145    606-159



**P. 61**

**LEAFLET DISPENSERS**

**LEAFLET DISPENSERS**

606-190    606-206    606-207

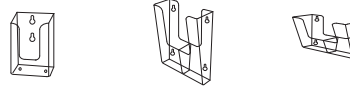

606-208    606-210

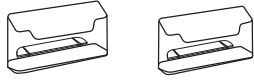

**P. 62**

**LEAFLET DISPENSERS**

**LEAFLET DISPENSERS**

606-209    607-082    604-028

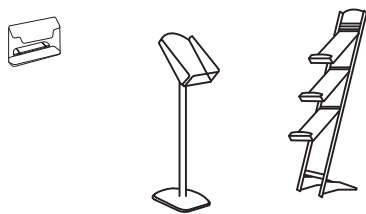

**P. 63**

**LEAFLET DISPENSERS**

**LEAFLET DISPENSERS**

606-146    606-459    606-196



611-084    611-085



**P. 64**

**LEAFLET DISPENSERS**

**LEAFLET HOLDERS**

606-212 - ...    606-214 - ...    606-202 - ...

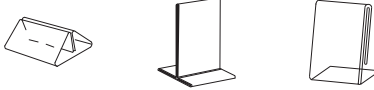

606-204 - ...    606-404 - ...



**P. 65**

**LEAFLET DISPENSERS**

**LEAFLET HOLDERS**

606-312 - ...    606-410 - ...    606-216 - ...



606-219    606-157 - ...



**P. 66**

**LEAFLET DISPENSERS**

**POCKETS**

611-147 - ...    611-251 - ...    611-126

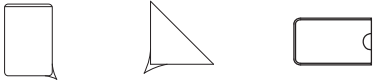

**P. 67**

**LEAFLET DISPENSERS**

**POCKETS**

611-162    611-219 - ...    611-279 - ...

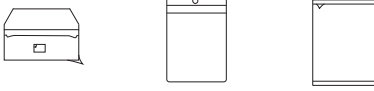

**P. 68**

**DISPLAY ACCESSORIES**

**DISPLAY ARMS AND ACCESSORIES**

601-210 - ...    601-206 - ...    601-209 - ...

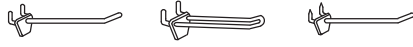

601-201 - ...    601-230



**P. 69**

**DISPLAY ACCESSORIES**

**DISPLAY ARMS AND ACCESSORIES**

601-337    601-111    601-117



601-120    601-129 - ...



**P. 70**

**DISPLAY ACCESSORIES**

**DISPLAY ARMS AND ACCESSORIES**

601-154 - ...    601-184 - ...    601-235

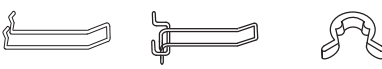

601-236    601-194



**P. 71**

**DISPLAY ACCESSORIES**

**DISPLAY ARMS AND ACCESSORIES**

601-227    601-219    601-360

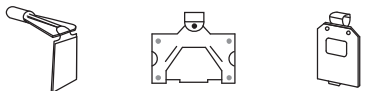

601-276    601-229



**P. 72**

**TO LOCATE YOUR CHOSEN ITEM, FOLLOW THE PAGE NUMBER INDICATED IN THE BOTTOM RIGHT HAND CORNER OF EACH FRAME.**

**DISPLAY ACCESSORIES**

**DISPLAY ARMS AND ACCESSORIES**

605-104    601-225    601-368



601-369    601-195



**P. 73**

**DISPLAY ACCESSORIES**

**DISPLAY ARMS AND ACCESSORIES**

601-800    601-801

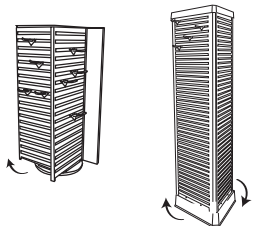

**P. 74**

**DISPLAY ACCESSORIES**

**HANG TABS**

L2-380µ    L3105-500µ    L3-500µ



P2000    300-903

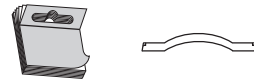

**P. 75**

**DISPLAY ACCESSORIES**

**FLAG ACCESSORIES**

604-038 - ...    604-050    604-051

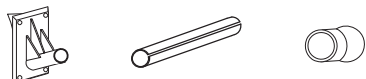

604-052



**P. 76**

**DISPLAY ACCESSORIES**

**POLE ACCESSORIES**

604-080    604-073    604-074

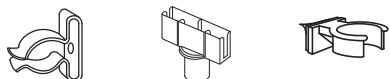

604-075    604-076    604-077

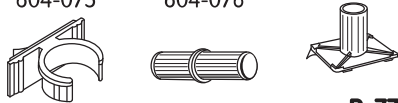

**P. 77**

**DISPLAY ACCESSORIES**

**TURNTABLES**

602-109    602-081    602-095



602-096    611-083



**P. 78**

**DISPLAY ACCESSORIES**

**DISPLAY CONSTRUCTION**

609-004    609-003    609-001



609-002    609-015

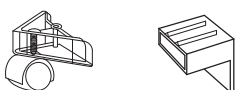

**P. 79**

**DISPLAY ACCESSORIES**

**DISPLAY CONSTRUCTION**

609-014    609-005    609-010

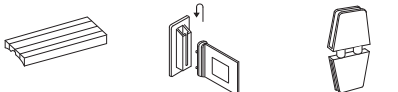

609-011    609-013



**P. 80**

**DISPLAY ACCESSORIES**

**DISPLAY CONSTRUCTION**

609-017    609-006    609-007

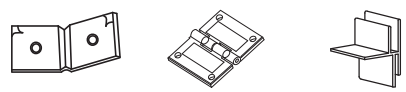

609-008    609-016



**P. 81**

**PRINTING ACCESSORIES**

**RIVETS**

611-246 - ...    611-086 - ...    611-195 - ...



611-088 - ...    611-097 - ...



**P. 82**

**PRINTING ACCESSORIES**

**RIVETS**

611-150 - ...    611-091 - ...    611-297 - ...



611-240    611-240



**P. 83**

**PRINTING ACCESSORIES**

**RIVETS**

611-157 - ...    611-093 - ...    611-236



611-243

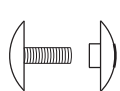

**P. 84**

**TO LOCATE YOUR CHOSEN ITEM, FOLLOW THE PAGE NUMBER INDICATED  
IN THE BOTTOM RIGHT HAND CORNER OF EACH FRAME.**

**PRINTING ACCESSORIES**

**HOOKS AND LOOPS**

611-280 - ...    611-286    611-287 - 611-288



611-289 - ...



**P. 85**

**PRINTING ACCESSORIES**

**TAPE AND MAGNETIC TAPE**

611-252 - ...    611-254    611-256



611-258



**P. 86**

**PRINTING ACCESSORIES**

**TAPE AND MAGNETIC TAPE**

611-257    611-259    611-260

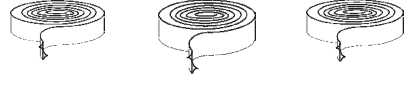

611-261

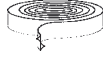

**P. 87**

**PRINTING ACCESSORIES**

**TAPE AND MAGNETIC TAPE**

611-263    611-262    611-264

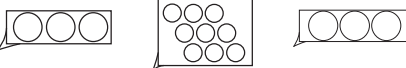

611-255



**P. 88**

**PRINTING ACCESSORIES**

**TAPE AND MAGNETIC TAPE**

611-250    611-179    611-267 - 611-268



611-156



**P. 89**

**PRINTING ACCESSORIES**

**DOCUMENT HOLDERS**

611-112    611-113    611-114



611-249

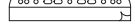

**P. 90**

**PRINTING ACCESSORIES**

**CD-ACCESSORIES**

611-137    611-138    611-270

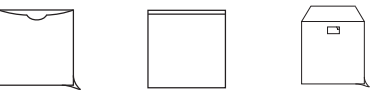

611-139    611-140



**P. 91**

**PRINTING ACCESSORIES**

**CD-ACCESSORIES**

611-271    611-071    611-148



611-072    611-149 - 611-296



**P. 92**

**PRINTING ACCESSORIES**

**CHAINS**

611-227    611-300    611-301 - 611-228



611-229 - 611-230    611-231



**P. 93**

**PRINTING ACCESSORIES**

**CHAINS**

611-232    611-011    611-225



611-226



**P. 94**

**PRINTING ACCESSORIES**

**RINGS AND HOOKS**

601-170 - 601-232    601-254    601-166 - ...



601-174



**P. 95**

**PRINTING ACCESSORIES**

**RINGS AND HOOKS**

601-173 - ...    611-001 - 611-002    611-215



611-003 - 611-004



**P. 96**



**TO LOCATE YOUR CHOSEN ITEM, FOLLOW THE PAGE NUMBER INDICATED IN THE BOTTOM RIGHT HAND CORNER OF EACH FRAME.**

**PRINTING ACCESSORIES**

**RINGS AND HOOKS**

611-216    611-005 - ...    611-163

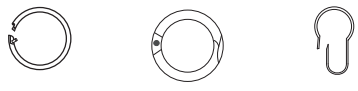

604-008 - ...    609-009



**P. 97**

**FRAMES**

**SNAP FRAMES**

608-011 - ...    608-025    608-117 - ...



608-097 - ...

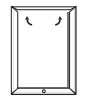

**P. 98**

**FRAMES**

**SNAP FRAMES**

608-130 - ...    608-112 - ...    608-137 - ...

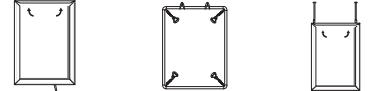

608-143 - ...

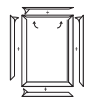

**P. 99**

**FRAMES**

**SNAP FRAMES**

608-133 - 608-134    608-151 - ...

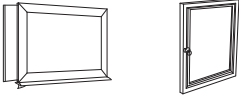

608-029 - ...

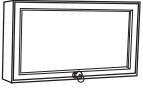

**P. 100**

**FRAMES**

**ALUMINIUM SHOWCARD STANDS**

606-460 - 606-461    606-464    606-199 - 606-200

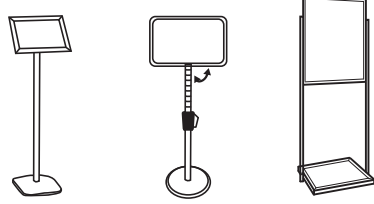

**P. 101**

**FRAMES**

**PLASTIC SHOWCARD STANDS AND ACCESSORIES**

607-064 - ...    607-066 - ...    607-065 - ...

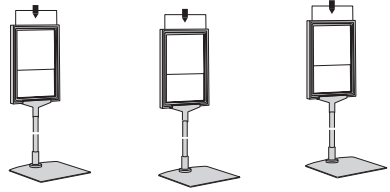

**P. 102**

**FRAMES**

**PLASTIC SHOWCARD STANDS AND ACCESSORIES**

607-071 - ...    607-081    607-023



**P. 103**

**FRAMES**

**PLASTIC SHOWCARD STANDS AND ACCESSORIES**

607-079    607-080    607-076



607-077    607-078



**P. 104**

**FRAMES**

**PAVEMENT SIGNS**

607-053 - ...    607-090    607-046 - ...



607-088 - ...



**P. 105**

**FRAMES**

**PAVEMENT SIGNS**

607-050 - ...    607-085    607-084

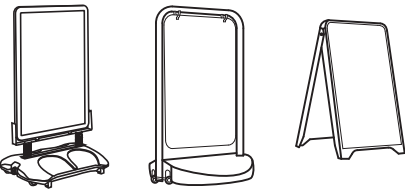

**P. 106**

**FRAMES**

**BANNER DISPLAYS**

608-005 - 608-030    608-102 - 608-101    608-104 - ...



608-107 - 608-106



**P. 107**

**FRAMES**

**BANNER DISPLAYS**

608-108    608-006    608-116

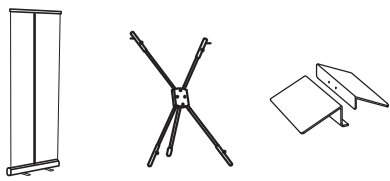

**P. 108**

**TO LOCATE YOUR CHOSEN ITEM, FOLLOW THE PAGE NUMBER INDICATED  
IN THE BOTTOM RIGHT HAND CORNER OF EACH FRAME.**

**FRAMES**

**SHOP-WINDOW PRESENTATION**

604-066      604-067      604-068 - 604-069



**P. 109**

**FRAMES**

**SHOP-WINDOW PRESENTATION**

604-070      604-071      604-072

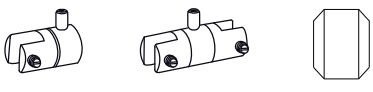

**P. 110**

**MISCELLANEOUS**

**SECURITY SYSTEMS**

602-066      602-092      602-067 - 602-084



602-083      602-064



**P. 111**

**MISCELLANEOUS**

**HANDLES**

609-100      609-101      609-102



609-104



**P. 112**

**MISCELLANEOUS**

**HANDLES**

609-104      609-114      609-106

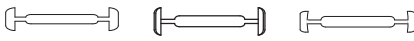

609-107      609-108



**P. 113**

**MISCELLANEOUS**

**HANDLES**

609-109      609-112      609-110



609-111      609-113



**P. 114**

**MISCELLANEOUS**

**CALENDAR ACCESSORIES**

800-004      800-001      800-002



800-003



**P. 115**

**MISCELLANEOUS**

**CALENDAR ACCESSORIES**

**WINDOWS**

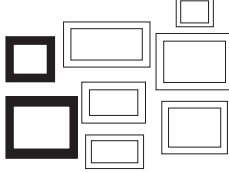

**P. 116**

Product ref	Page no	Product ref	Page no	Product ref	Page no	Product ref	Page no	Product ref	Page no
200-002	32	601-175	95	602-005	4	602-116	4	603-052	47
200-007	32	601-176	95	602-006	40	602-128	5	603-053	47
200-009	33	601-177	95	602-007	2	602-143	4	603-054	35
200-010	33	601-178	96	602-008	1	602-200	9	603-055	15
200-011	33	601-179	96	602-009	1	602-201	9	603-056	37
200-013	33	601-180	71	602-010	54	602-202	9	603-057	39
200-014	33	601-182	71	602-011	54	603-001	15	603-058	37
200-017	32	601-184	71	602-012	39	603-002	15	603-059	37
200-019	32	601-185	71	602-013	4	603-003	35	603-060	37
200-020	34	601-186	71	602-014	4	603-004	35	603-061	48
200-033	33	601-187	71	602-015	4	603-005	35	603-063	43
200-034	33	601-188	71	602-016	4	603-006	35	603-064	45
200-035	33	601-194	71	602-017	4	603-006	36	603-065	45
200-036	33	601-195	73	602-018	4	603-007	36	603-066	35
200-038	31	601-201	69	602-019	55	603-008	36	603-067	38
200-039	31	601-203	69	602-022	54	603-009	38	603-068	38
200-040	31	601-204	69	602-023	55	603-010	38	603-069	16
200-041	31	601-205	69	602-024	54	603-011	38	603-070	17
200-042	31	601-206	69	602-026	5	603-012	38	603-071	15
200-043	31	601-207	69	602-027	5	603-013	38	603-072	46
200-044	31	601-208	69	602-028	56	603-014	38	603-100	36
200-045	31	601-209	69	602-029	56	603-015	39	603-101	43
200-046	31	601-210	69	602-030	56	603-016	17	603-102	36
200-047	31	601-211	69	602-031	55	603-017	41	603-103	41
200-048	31	601-212	69	602-032	55	603-018	41	603-104	36
200-049	31	601-213	69	602-043	9	603-019	1	603-105	35
200-050	32	601-214	69	602-044	3	603-021	42	603-108	42
200-200	33	601-219	72	602-045	3	603-022	42	604-001	6
300-903	75	601-225	73	602-046	3	603-024	42	604-002	7
601-100	28	601-227	72	602-047	3	603-025	43	604-003	6
601-111	70	601-229	72	602-048	4	603-026	43	604-004	6
601-117	70	601-230	69	602-054	54	603-027	44	604-008	97
601-118	41	601-232	29	602-055	16	603-028	44	604-009	8
601-120	70	601-232	95	602-056	16	603-029	44	604-011	2
601-127	27	601-234	27	602-057	2	603-030	44	604-018	21
601-128	29	601-235	71	602-062	40	603-031	45	604-019	21
601-129	70	601-236	71	602-064	111	603-032	45	604-020	21
601-132	26	601-237	27	602-066	111	603-033	46	604-021	21
601-133	26	601-252	69	602-067	111	603-034	42	604-022	21
601-134	26	601-254	29	602-081	78	603-035	39	604-025	8
601-140	28	601-254	95	602-083	111	603-037	17	604-026	8
601-141	70	601-258	71	602-084	111	603-038	15	604-028	63
601-142	70	601-276	72	602-085	59	603-039	17	604-029	8
601-148	70	601-337	70	602-088	2	603-040	43	604-030	8
601-153	70	601-338	28	602-089	2	603-041	44	604-031	8
601-154	71	601-360	72	602-091	55	603-042	45	604-032	8
601-166	95	601-367	26	602-092	111	603-043	36	604-033	8
601-168	71	601-368	73	602-095	78	603-044	46	604-034	8
601-169	4	601-369	73	602-096	78	603-045	35	604-035	20
601-170	29	601-800	74	602-100	4	603-046	37	604-036	20
601-170	95	601-801	74	602-102	4	603-047	37	604-038	76
601-171	71	602-001	1	602-106	4	603-048	35	604-040	8
601-172	71	602-002	1	602-108	56	603-049	17	604-042	6
601-173	96	602-003	1	602-109	78	603-050	39	604-043	6
601-174	95	602-004	3	602-115	4	603-051	47	604-044	6

Product ref	Page no
604-045	8
604-046	8
604-047	7
604-048	8
604-049	76
604-050	76
604-051	76
604-052	76
604-053	97
604-054	97
604-055	8
604-056	8
604-057	8
604-058	8
604-059	8
604-060	8
604-061	8
604-062	8
604-063	8
604-064	8
604-065	8
604-066	109
604-067	109
604-068	109
604-069	109
604-070	110
604-071	110
604-072	110
604-073	77
604-074	77
604-075	77
604-076	77
604-077	77
604-078	7
604-079	7
604-080	77
605-005	10
605-007	10
605-010	11
605-011	12
605-012	12
605-013	36
605-014	46
605-018	23
605-019	23
605-020	23
605-021	23
605-022	23
605-023	23
605-024	48
605-026	11
605-027	19
605-028	49
605-029	49
605-030	48

Product ref	Page no
605-031	48
605-032	23
605-033	24
605-034	23
605-035	23
605-036	23
605-037	23
605-038	24
605-040	24
605-042	47
605-043	25
605-045	49
605-048	11
605-049	50
605-050	51
605-051	51
605-052	51
605-058	11
605-060	18
605-064	18
605-066	12
605-067	11
605-068	11
605-069	25
605-070	25
605-071	25
605-100	24
605-101	24
605-102	23
605-104	73
605-106	24
605-108	24
605-111	51
605-112	18
605-122	18
605-123	36
605-127	22
605-129	22
605-130	18
605-130	22
605-131	22
605-132	48
605-133	34
605-134	18
605-137	12
605-140	49
605-143	23
605-145	12
605-146	49
605-147	50
605-148	50
605-149	50
605-150	50
605-151	52
605-152	52

Product ref	Page no
605-153	52
605-154	53
605-155	53
605-156	53
605-157	53
605-158	47
605-159	47
605-160	13
605-161	10
605-162	10
605-163	10
605-164	14
605-165	14
605-166	10
605-168	13
605-169	13
605-170	13
605-171	13
605-172	18
605-173	12
605-174	12
606-137	66
606-138	66
606-139	66
606-140	66
606-141	66
606-142	66
606-143	66
606-144	60
606-145	61
606-146	64
606-147	60
606-148	60
606-149	61
606-150	61
606-151	61
606-157	66
606-159	61
606-174	60
606-190	62
606-191	65
606-196	64
606-197	66
606-198	66
606-199	101
606-200	101
606-201	65
606-202	65
606-203	65
606-204	65
606-205	65
606-206	62
606-207	62
606-208	62
606-209	63

Product ref	Page no
606-210	62
606-211	65
606-212	65
606-213	65
606-214	65
606-215	65
606-216	66
606-217	66
606-218	66
606-219	66
606-304	60
606-305	60
606-307	60
606-311	66
606-312	66
606-401	65
606-403	65
606-404	65
606-409	66
606-410	66
606-413	65
606-415	65
606-430	65
606-459	64
606-460	101
606-461	101
606-464	101
606-465	65
607-018	102
607-023	103
607-024	105
607-034	103
607-035	103
607-036	103
607-044	105
607-046	105
607-047	105
607-048	106
607-049	106
607-050	106
607-051	105
607-052	105
607-053	105
607-054	105
607-062	105
607-064	102
607-065	102
607-066	102
607-067	102
607-068	102
607-069	102
607-070	102
607-071	103
607-072	103
607-073	103

Product ref	Page no
607-074	103
607-075	102
607-076	104
607-077	104
607-078	104
607-079	104
607-080	104
607-081	103
607-082	63
607-084	106
607-085	106
607-086	105
607-088	105
607-089	105
607-090	105
607-091	106
608-001	19
608-002	19
608-003	20
608-004	20
608-005	107
608-006	108
608-011	98
608-012	98
608-013	98
608-017	98
608-021	19
608-023	19
608-024	98
608-025	98
608-026	99
608-027	99
608-028	100
608-029	100
608-030	107
608-032	100
608-033	100
608-034	98
608-035	98
608-036	98
608-037	98
608-050	100
608-058	98
608-095	98
608-096	98
608-097	98
608-098	98
608-099	98
608-101	107
608-102	107
608-103	107
608-104	107
608-105	107
608-106	107
608-107	107



Product ref	Page no	Product ref	Page no	Product ref	Page no	Product ref	Page no	Product ref	Page no
608-108	108	609-014	80	611-101	83	611-208	67	611-269	67
608-111	99	609-015	79	611-102	83	611-209	67	611-270	91
608-112	99	609-016	81	611-103	83	611-215	96	611-271	92
608-113	99	609-017	81	611-104	83	611-216	97	611-272	68
608-114	99	609-100	112	611-105	83	611-217	59	611-273	68
608-115	20	609-101	112	611-106	83	611-219	68	611-274	68
608-116	108	609-102	112	611-107	83	611-220	68	611-275	68
608-117	98	609-103	112	611-111	84	611-221	68	611-276	68
608-118	98	609-104	113	611-112	90	611-222	68	611-277	68
608-119	98	609-106	113	611-113	90	611-223	58	611-278	68
608-120	98	609-107	113	611-114	90	611-224	58	611-279	68
608-121	98	609-108	113	611-115	57	611-225	94	611-280	67
608-122	98	609-109	114	611-116	57	611-226	94	611-280	85
608-123	98	609-110	114	611-117	57	611-227	93	611-281	85
608-124	98	609-111	114	611-118	57	611-228	93	611-282	85
608-125	98	609-112	114	611-119	57	611-229	93	611-283	85
608-127	98	609-113	114	611-121	58	611-230	93	611-284	85
608-128	99	609-114	113	611-122	59	611-231	93	611-285	85
608-129	99	611-001	96	611-126	67	611-232	94	611-286	85
608-130	99	611-002	96	611-127	59	611-233	40	611-287	85
608-131	99	611-003	96	611-129	59	611-234	40	611-288	85
608-132	99	611-004	96	611-131	67	611-235	40	611-289	85
608-133	100	611-005	97	611-132	67	611-236	84	611-290	85
608-134	100	611-006	97	611-133	67	611-237	83	611-291	85
608-135	99	611-007	97	611-134	67	611-238	83	611-292	85
608-136	99	611-008	97	611-135	67	611-239	83	611-293	85
608-137	99	611-009	97	611-136	67	611-240	83	611-295	85
608-138	99	611-010	97	611-137	91	611-240	83	611-296	92
608-139	99	611-011	94	611-138	91	611-242	34	611-297	83
608-140	99	611-012	58	611-139	91	611-243	84	611-298	83
608-141	99	611-035	86	611-140	91	611-244	82	611-299	83
608-142	99	611-061	34	611-141	83	611-245	82	611-300	93
608-143	99	611-071	92	611-142	97	611-246	82	611-301	93
608-144	99	611-072	92	611-143	97	611-247	82	612-003	30
608-145	99	611-074	34	611-146	67	611-248	82	612-004	30
608-146	99	611-078	32	611-147	67	611-249	90	612-005	30
608-147	99	611-079	32	611-148	92	611-250	89	612-006	30
608-149	100	611-080	32	611-149	92	611-251	67	612-008	30
608-151	100	611-081	51	611-150	83	611-252	86	612-009	30
608-152	100	611-083	78	611-151	83	611-253	86	612-011	30
608-153	100	611-084	64	611-152	83	611-254	86	612-013	30
608-154	100	611-085	64	611-156	89	611-255	88	650-142	23
608-155	99	611-086	82	611-157	84	611-256	86	800-001	115
609-001	79	611-087	82	611-158	84	611-257	87	800-002	115
609-002	79	611-088	82	611-159	84	611-258	86	800-003	115
609-003	79	611-089	82	611-160	84	611-259	87	800-004	115
609-004	79	611-091	83	611-161	84	611-260	87	L2-380μ	75
609-005	80	611-092	83	611-162	68	611-261	87	L3105-500μ	75
609-006	81	611-093	84	611-163	97	611-262	88	L3-500μ	75
609-007	81	611-095	82	611-164	58	611-263	88	P2000	75
609-008	81	611-096	82	611-165	59	611-264	88	X15	16
609-009	97	611-097	82	611-179	89	611-265	5		
609-010	80	611-098	83	611-195	82	611-266	5		
609-011	80	611-099	83	611-196	82	611-267	89		
609-013	80	611-100	83	611-197	82	611-268	89		

**CEILING DISCS AND POSTER PROFILES**

**CEILING DISCS**

**01**

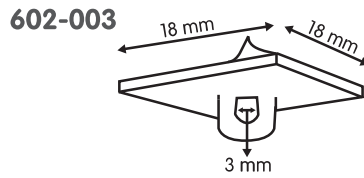

◎ **602-003 - 602-001**

White polypropylene ceiling disc with foam adhesive.

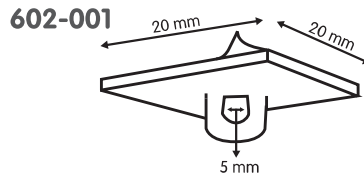

◎ **603-019**

Ticket attachment button in polystyrene for product labelling. No adhesive residue is left on the product when removed. Very high instant adhesion. The button is easily removed using the free tool supplied with every order.

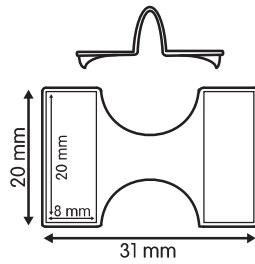
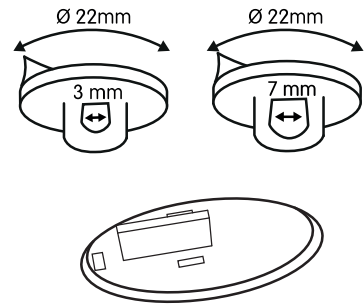

◎ **602-008**

Clear PET flexible ceiling disc with foam adhesive, suitable for hollow and round surfaces.

1000 pcs/roll

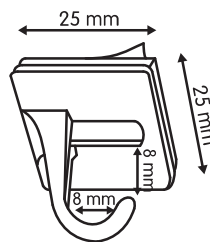

◎ **602-009**

White polypropylene ceiling hook with foam adhesive.

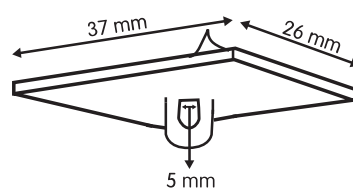

◎ **602-002**

White polypropylene ceiling disc with foam adhesive.

◎ **602-088**

White polypropylene rotating ceiling disc with foam adhesive.

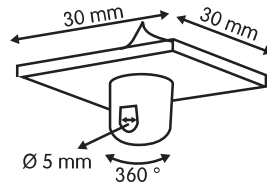

◎ **602-057**

White polypropylene ceiling hook with foam adhesive. Can also be used as pen clip.

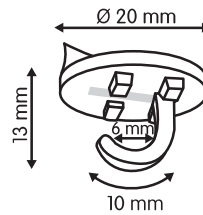

◎ **604-011**

White plastic self adhesive ceiling hanger for use with suspended ceiling T-rails.

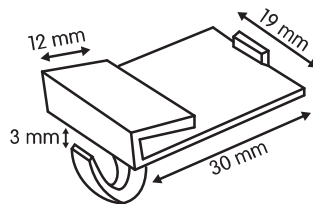

◎ **602-007**

Natural polypropylene slide-on ceiling disc for suspended ceilings.

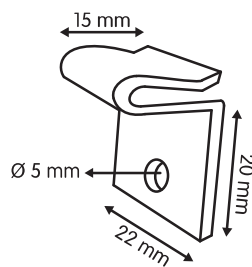

◎ **602-089**

Natural nylon slide-on ceiling disc for suspended ceilings.

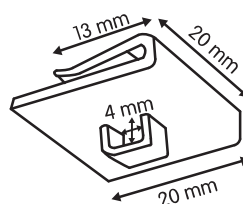

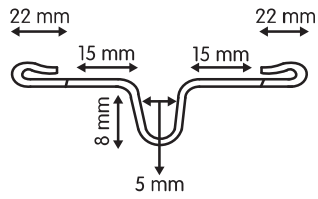

◎ **602-044**

Metal wire ceiling clip for suspended ceilings.

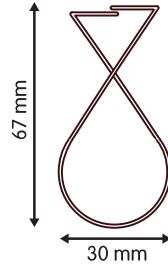
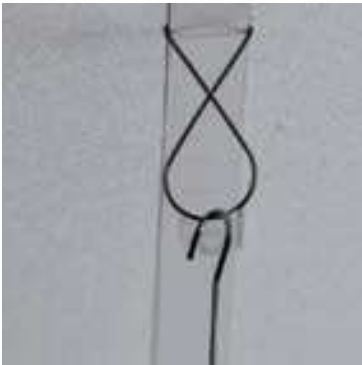

◎ **602-045**

Metal wire ceiling clip for suspended ceilings.

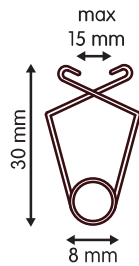

◎ **602-004**

Metal wire ceiling clip for suspended ceilings.

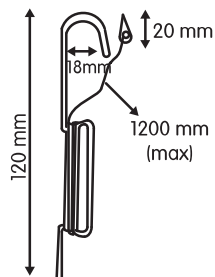

◎ **602-046**

Wire hook with nylon wire and metal tip.

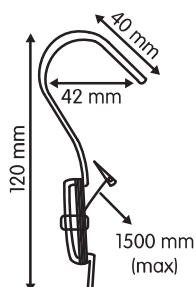

◎ **602-047**

Metal hook with nylon wire and metal tip.

◎ **602-048 - 602-115 - 602-116**

Adjustable wire ceiling hook.  
Just pull to the required length.

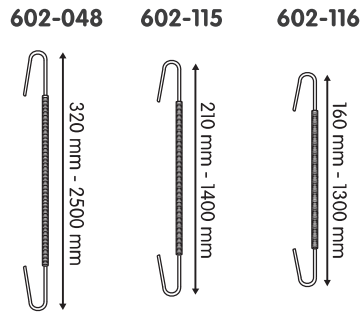

◎ **602-143**

Nylon wire on reels.

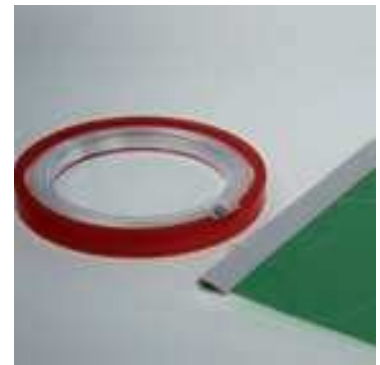
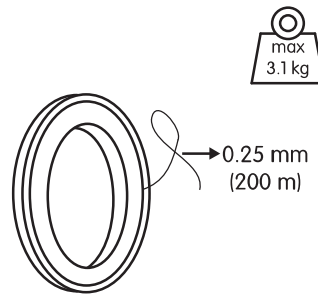

◎ **602-014 (40 MM) - 602-015 (80 MM)  
602-005 (120 MM) - 602-013 (160 MM)**

Twisted polyester thread to link poster cards.  
The dots on each end prevent the thread slipping out of the card.

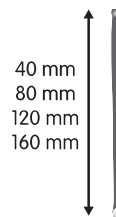

◎ **602-100 (100 MM) - 602-102 (200 MM)  
602-106 (500 MM) - 602-018 (750 MM)  
602-016 (1000 MM) - 602-017 (2000 MM)**

Galvanized wire ceiling hooks.

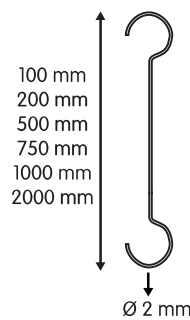

◎ **601-169**

2 part ceiling hook for heavier posters.  
The two parts are adjustable and secured using a metal spring clip.  
Standard pack consists of 2 x 1 metre hooks.

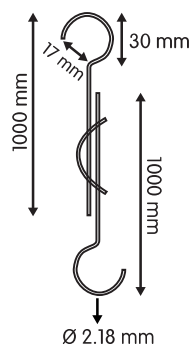

**CEILING DISCS AND POSTER PROFILES**  
**MAGNETIC CEILING HOOKS**

01

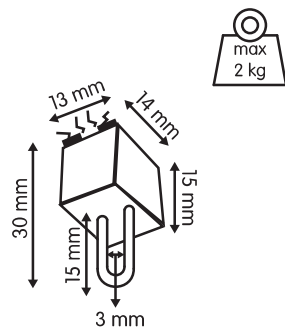

◎ **602-026**

White square magnetic hook.

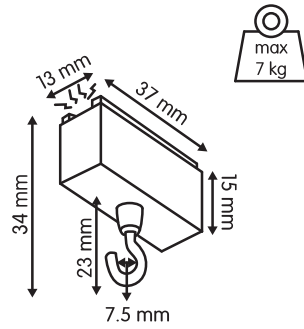

◎ **602-027**

White rectangular magnetic hook.

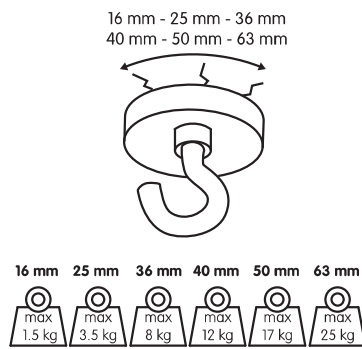

◎ **611-266**

Round plastic coated white magnetic hook.

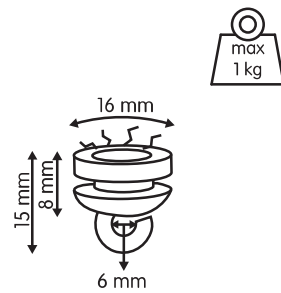

◎ **602-128**

Round transparent magnet hook.

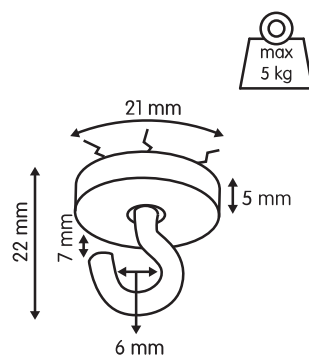

◎ **611-265**

Round plastic coated white magnetic hook.



◎ **604-003**

Poster profile in PVC.  
Colours: white - black - transparent.  
Standard lengths available from stock.  
Custom lengths can be cut to order.

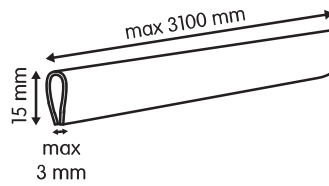

◎ **604-042 (WHITE) - 604-043 (BLACK)  
604-044 (CLEAR)**

Poster profile in polystyrene (matt) or PVC.  
Colours: white (PS) - transparent (PVC).  
Only available in the standard lengths shown.

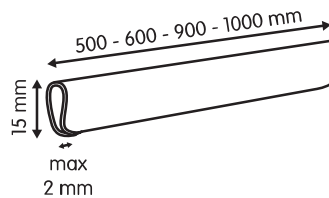

◎ **604-001**

Natural polypropylene poster hanger  
for poster profile 604-003 - 604-042/604-043/604-044.

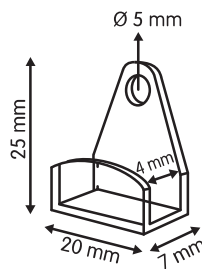

◎ **604-004**

Poster profile with clip mechanism in PVC.  
Colours: white - black - transparent.  
Standard lengths available from stock.  
Custom lengths can be cut to order.

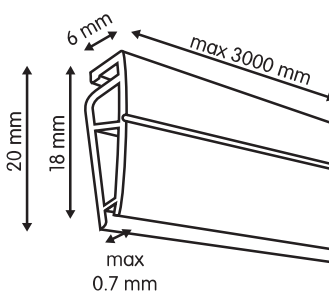

01

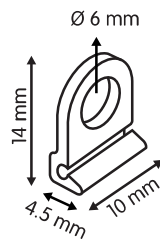

◎ **604-002**

Transparent polypropylene slide-on hanger with hole for use with poster profile 604-004.

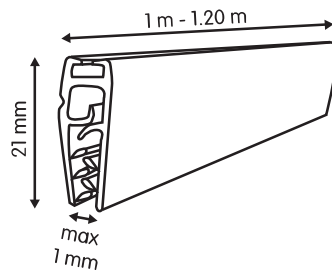

◎ **604-078**

Poster profile with supergrip in PVC. Colours: white - transparent. Only available in the standard lengths shown.

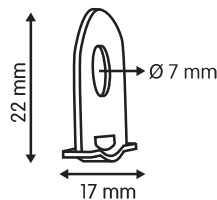

◎ **604-079**

Transparent polypropylene slide-on hanger with hole for use with poster profile 604-078.

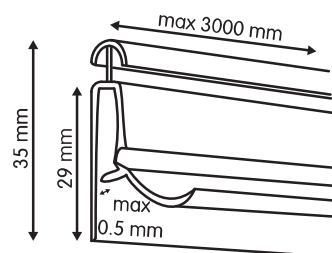

◎ **604-047** **NEW**

Poster profile with clip mechanism in transparent PVC.

© 604-048 **NEW**

Transparent ABS poster hanger for use with poster profile 604-047

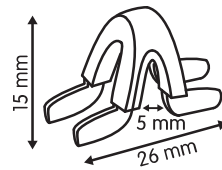

01

© 604-025 (210 MM) - 604-026 (300 MM)  
604-040 (420 MM)

Natural aluminium profile.  
1 set consists of: upper profile, 2 plastic rolls on the inside to secure the poster, 2 hangers and 2 end caps.

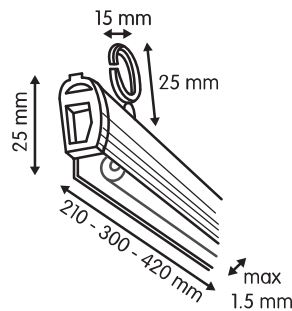

© 604-029 (42 CM) - 604-030 (50 CM)  
604-031 (60 CM) - 604-032 (70 CM)  
604-033 (85 CM) - 604-057 (90 CM)  
604-009 (100 CM) - 604-034 (120 CM)  
604-055 (125 CM) - 604-045 (150 CM)  
604-056 (200 CM) - 604-046 (250 CM)

Natural aluminium clip profile.  
1 set consists of: lower profile, upper profile, 2 hangers and 4 end caps.

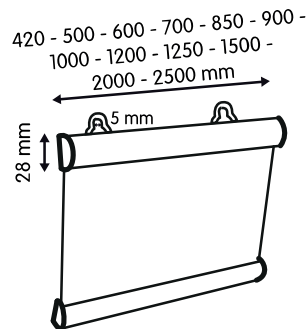

© 604-060 (30 CM) - 604-061 (42 CM)  
604-062 (50 CM) - 604-063 (60 CM)  
604-064 (70 CM) - 604-065 (80 CM)  
604-058 (100 CM) - 604-059 (150 CM)

Natural aluminium clip profile, round.  
1 set consists of: lower profile, upper profile, 2 hangers and 4 end caps.

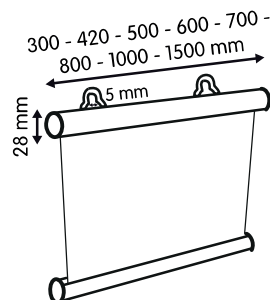

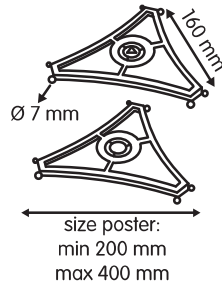

◎ **602-201**

3-dimensional mobile hanger in natural polypropylene.

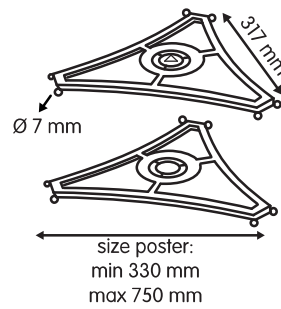

◎ **602-200**

3-dimensional mobile hanger in natural polypropylene.

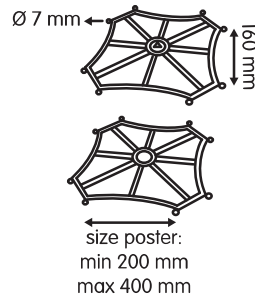

◎ **602-202**

4-dimensional mobile hanger in natural polypropylene.

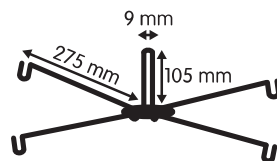

◎ **602-043**

4-sided, black metal mobile.

◎ **605-007 - 605-005**

Clear wobbler (250 μ or 380 μ) PET with permanent adhesive on each end.  
 Packaging: 10 pcs/sheet.

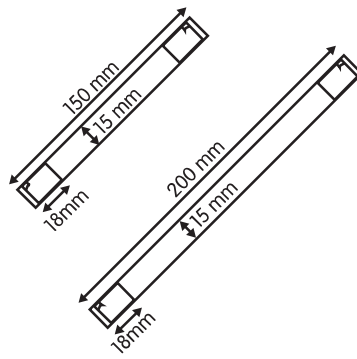

02

◎ **605-161**

Clear wobbler in 400 micron PVC with adhesive on one end.  
 Enables the message to be display at 90° to the shelf.

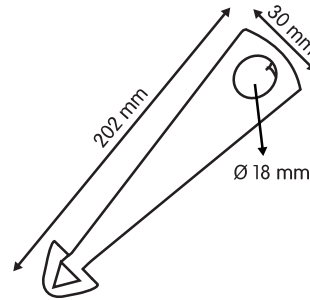

◎ **605-162**

Clear wobbler in 400 micron PVC with permanent adhesive on each end.

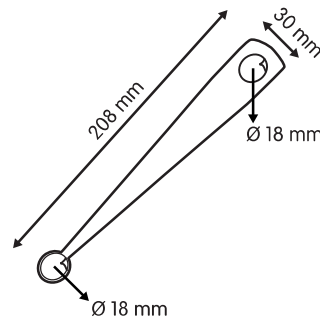

◎ **605-163**

Clear wobbler in 400 micron PVC with permanent adhesive on each end.  
 Especially for lightweight cards.

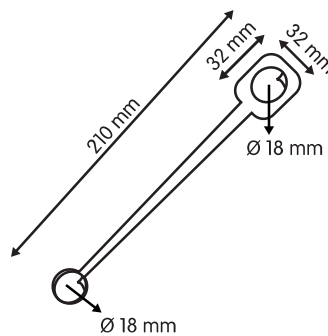

◎ **605-166**

Clear PVC wobbler with permanent adhesive on each end.

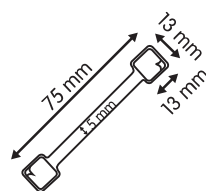

**SHELF FITTING ACCESSORIES**  
**WOBLERS**

02

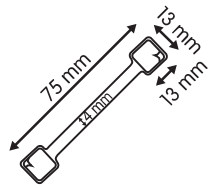

◎ **605-067**

Flexible aluminium wobbler with small adhesive pads on each end. Can be manipulated into different positions.

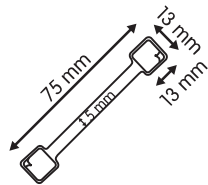

◎ **605-048**

Flexible aluminium wobbler with small adhesive pads on each end. **One adhesive pad is removable.** Can be manipulated into different positions.

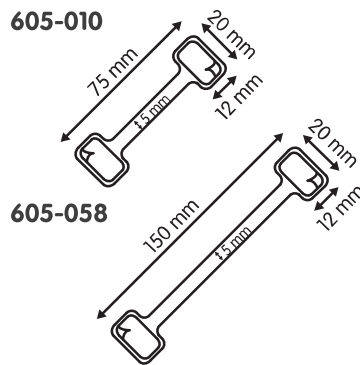

◎ **605-010 - 605-058**

Flexible aluminium wobbler with adhesive pads on each end. Can be manipulated into different positions.

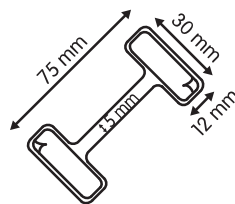

◎ **605-026** **NEW**

Flexible aluminium wobbler with 'large' adhesive pads on each end. Can be manipulated into different positions.

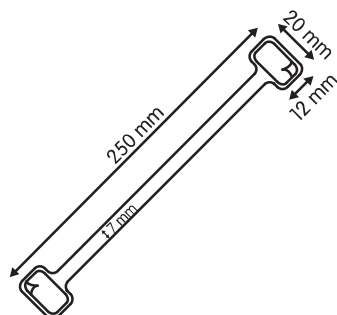

◎ **605-068** **NEW**

Extra large flexible aluminium wobbler with adhesive pads on each end. Can be manipulated into different positions.



◎ **605-066**

White metal wobbler with round adhesive pads at each end. One end has a pad on each side. Can be manipulated into different positions.

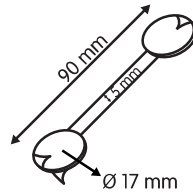

02

◎ **605-011**

Spring wobbler with adhesive pads on each end.

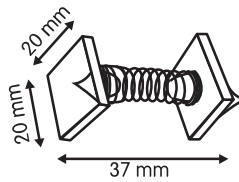

◎ **605-137**

Spring wobbler with a suction cup on one end and a foam pad on the other.

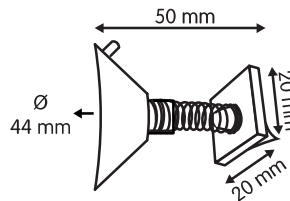

◎ **605-145 - 605-173**

Spring wobbler with gripper on one end and an adhesive pad on the other.

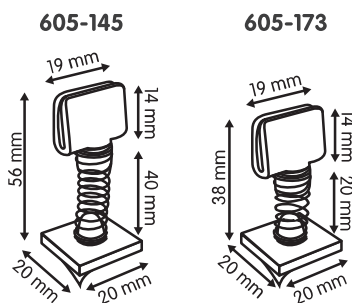

◎ **605-012 - 605-174**

White polypropylene spacer with adhesive on both ends. Creates a space between 2 signs.

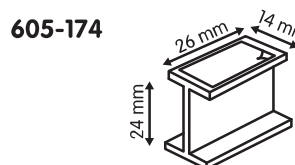
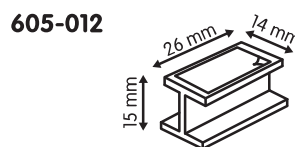

## SHelf FITTING ACCESSORIES

### WOBBLERS

02

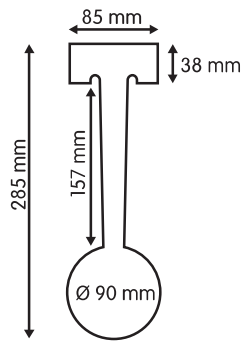

#### 605-168

Printing wobbler in paper (macosat - 300 g) or PVC (300 micron).  
Optional: adhesive pad.  
**ON REQUEST (minimum 500 pcs).**

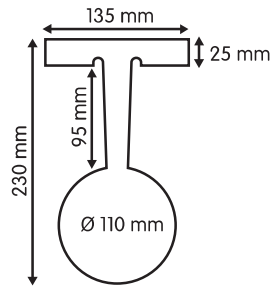

#### 605-169

Printing wobbler in paper (macosat - 300 g) or PVC (300 micron).  
Optional: adhesive pad.  
**ON REQUEST (minimum 500 pcs).**

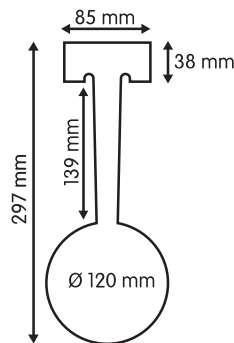

#### 605-170

Printing wobbler in paper (macosat - 300 g) or PVC (300 micron).  
Optional: adhesive pad.  
**ON REQUEST (minimum 500 pcs).**

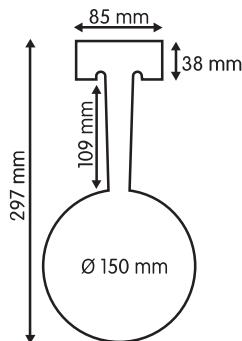

#### 605-171

Printing wobbler in paper (macosat - 300 g) or PVC (300 micron).  
Optional: adhesive pad.  
**ON REQUEST (minimum 500 pcs).**

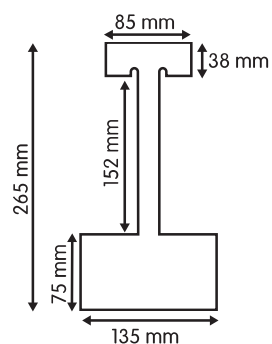

#### 605-160

Printing wobbler in paper (macosat - 300 g) or PVC (300 micron).  
Optional: adhesive pad.  
**ON REQUEST (minimum 500 pcs).**

© 605-164 **NEW**

Clear wobbler in 500 micron PVC.  
Creates greater visibility by displaying the message at 90° on the shelf.

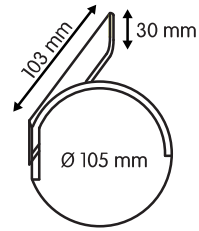

02

© 605-165 **NEW**

Clear wobbler in 500 micron PVC.

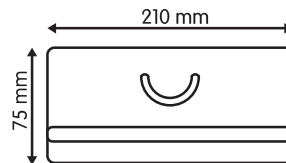

**SHELF FITTING ACCESSORIES**  
SIGN HOLDERS

02

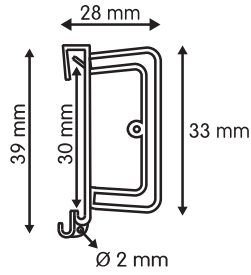

◎ **603-002**

Sign holder with hole at the bottom to attach leaflets.  
To be used with 605-018 and 605-022.

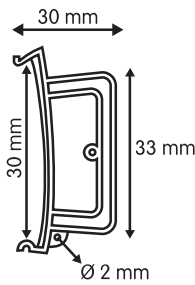

◎ **603-055**

Sign holder with hole at the bottom to attach leaflets. To be used with 'C'-profile.

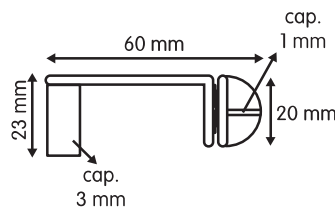

◎ **603-038**

White clip for use with shelf dividers.  
Ticketing can be placed in various positions.

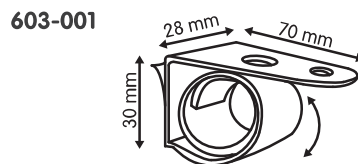

◎ **603-001 - 603-071**

Snail clip with or without adhesive on the front.

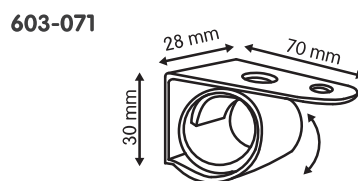



◎ **X15**

White plastic slide-on hook (large style).

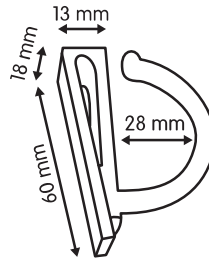

02

◎ **602-055**

White plastic slide-on hook.

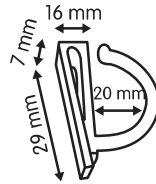

◎ **602-056**

White plastic slide-on hook with adhesive.

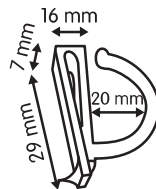

◎ **603-069** **NEW**

Clear PVC flexible card holder without adhesive for glass shelves. Hinges for easy access to products by customers.

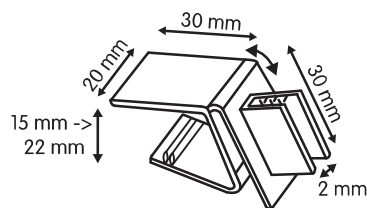

**SHELF FITTING ACCESSORIES**  
SIGN HOLDERS

02

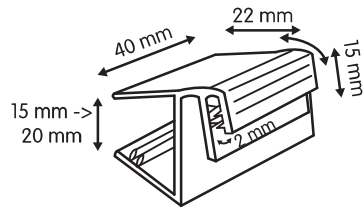

◎ **603-070** **NEW**

Clear PVC flexible card holder without adhesive for glass shelves. Hinges for easy access to products by customers.



**603-016**

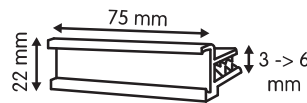

◎ **603-016 (22 MM)**  
**603-049 (39 MM)**

Clear PVC glass shelf sign holder.



**603-049**

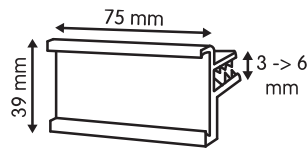

◎ **603-037**

Clear PVC glass shelf sign holder.

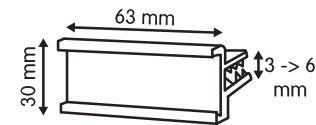

◎ **603-039**

Clear PVC glass shelf sign holder.

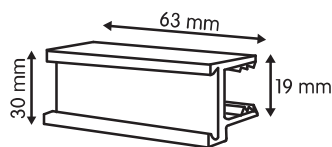



◎ **605-134 (8 MM) - 605-060 (18 MM)**

Natural polypropylene coupon holder with/without adhesive or supergrip.

Capacity:

\* 8 mm (= 75 coupons at 115 g/m<sup>2</sup>)

\* 18 mm (= 125 coupons at 115 g/m<sup>2</sup>)

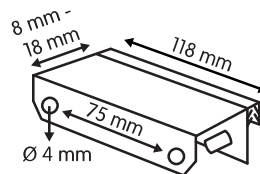

02

◎ **605-172 (8 MM) - 605-064 (18 MM)**

Natural polypropylene 'mini' coupon holder with/without adhesive or supergrip.

Capacity:

\* 8 mm (= 75 coupons at 115 g/m<sup>2</sup>)

\* 18 mm (= 125 coupons at 115 g/m<sup>2</sup>)

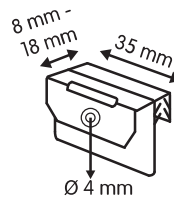

◎ **605-112**

Natural polypropylene shelf plate with coupon holder (ref: 605-134 or 605-060). For use with electronic pricing unit available separately. Shelf plate is also available not attached.

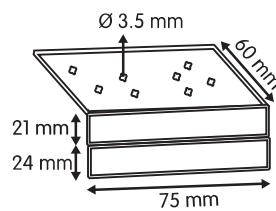

◎ **605-130**

Metal clip to attach shelf plate (ref: 605-112) to the shelf.

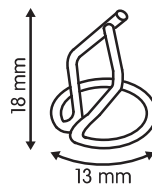

◎ **605-122**

Natural polypropylene shelf plate with coupon holder (ref: 605-134 or 605-060). For use with electronic pricing unit available separately. Shelf plate is also available not attached.

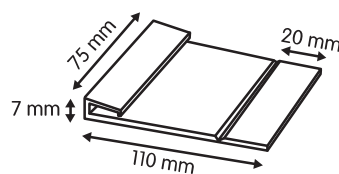

**SHELF FITTING ACCESSORIES**  
**BANNER HOLDERS**

02

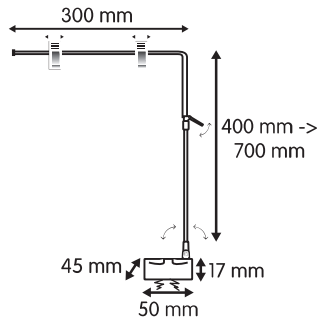

◎ **608-023**

Banner holder complete with magnet, telescopic aluminium L-tube (90° angle) and 2 clips.

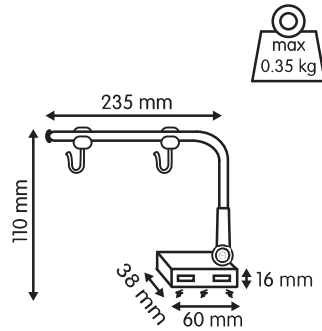

◎ **608-021**

Banner holder complete with magnet, aluminium L-tube (90° angle) and 2 plastic clips.

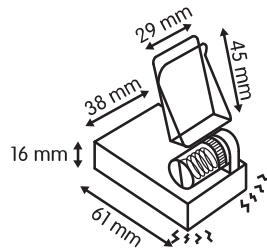
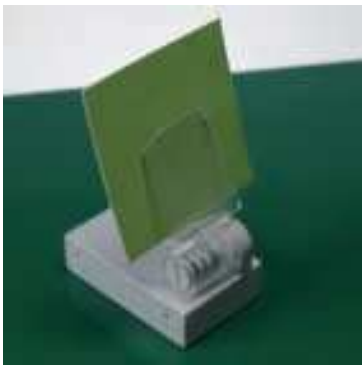

◎ **605-027**

**NEW**

Magnetic card holder with adjustable angle (180 degrees).

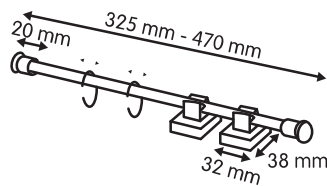

◎ **608-001**

Banner hanger complete with 2 magnets, chromed tube with end cap, 2 black plastic rings and 2 'C' hooks.

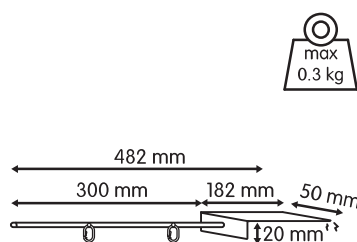

◎ **608-002**

Magnetic white coated banner hanger complete with 1 flat magnet, banner tube and 2 hooks.

◎ **608-003**

Magnetic white plastic banner hanger complete with 1 magnet, banner tube and 2 oval plastic hooks.

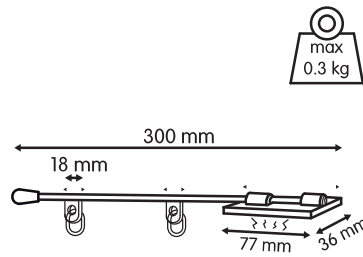

**02**

◎ **608-004**

White plastic banner hanger complete with 2 adhesive discs, banner tube and 2 oval plastic hooks.

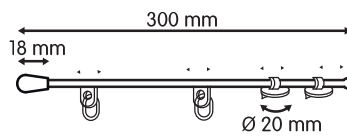

◎ **608-115**

**NEW**

White plastic banner hanger complete with 2 suction cups, banner tube and 2 oval plastic hooks.

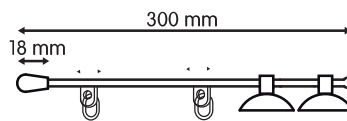

◎ **604-035**

Transparent channel with ridges for extra grip on the inside.

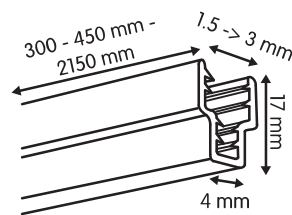

◎ **604-036**

L-shape magnetic base for use with transparent channel (ref: 604-035). Standard colours: white - black.

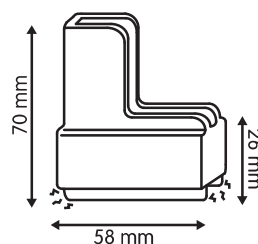

**SHELF FITTING ACCESSORIES**  
**BANNER HOLDERS**

02

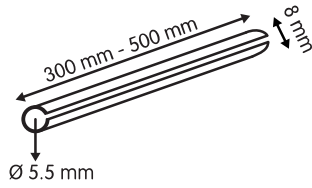
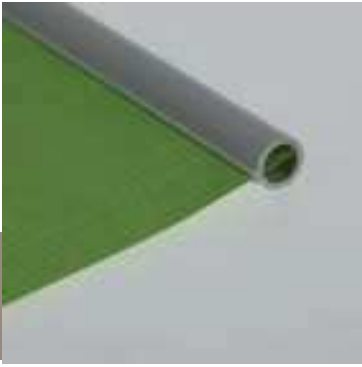

◎ **604-018**

White PVC flag pole with slit to secure the banner.

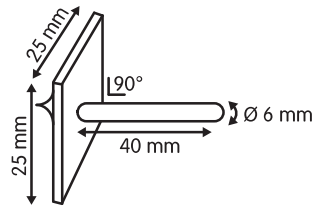

◎ **604-019**

White PVC flag pole holder (90 degree) with adhesive for use with flag pole (ref: 604-018).

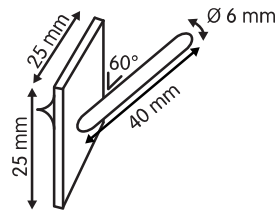

◎ **604-020**

White PVC flag pole holder (60 degree) with adhesive for use with flag pole (ref: 604-018).

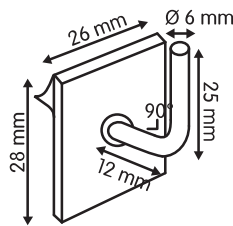

◎ **604-021**

White PVC flag pole holder with adhesive for use with flag pole (ref: 604-018).

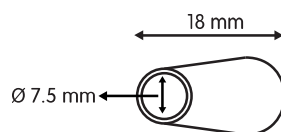

◎ **604-022**

White plastic end cap for use with flag pole (ref: 604-018).

21

◎ **605-127**

Fixed clear single side bracket.

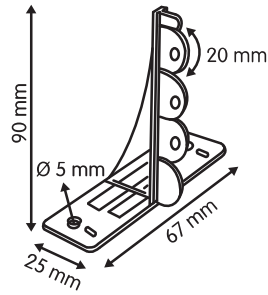

02

◎ **605-129**

Clear single side bracket.  
Adjustable in 3 positions: vertical, 45 degree or horizontal.

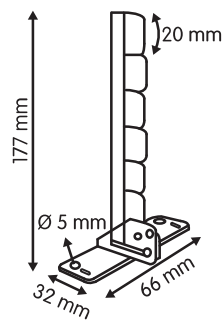

◎ **605-130**

Metal clips.  
For use with 605-127/605-129/605-131.

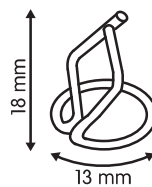

◎ **605-131**

White magnetic plate.  
For use with 605-127/605-129/605-130.

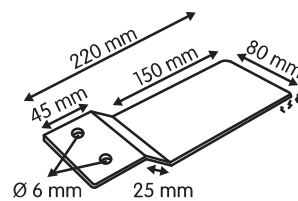



**605-035**

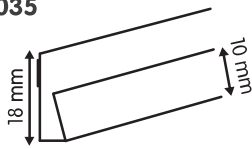

**605-034**

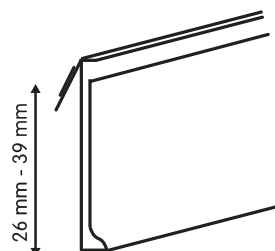
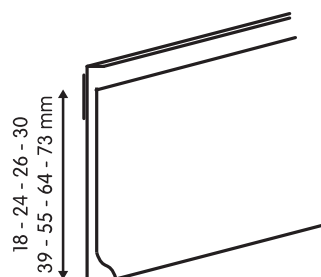
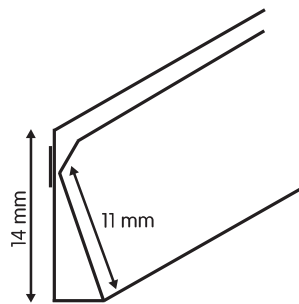
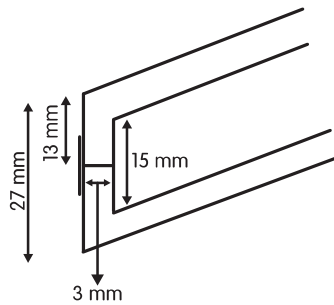
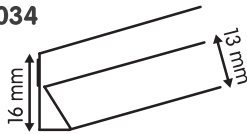

◎ **605-035 - 605-034**

Label holder in PVC, with or without adhesive.  
 Standard colours: transparent and white.  
 Always cut to size.

◎ **605-102**

Label holder in PVC, with or without adhesive.  
 Standard colours: white, black and grey.  
 Always cut to size.

◎ **605-036**

Label holder in PVC, with or without adhesive.  
 Standard colours: transparent and white.  
 Always cut to size.

◎ **605-019 (18 MM) - 605-020 (24 MM)**  
**605-021 (26 MM) - 605-018 (30 MM)**  
**605-022 (39 MM) - 605-142 (60 MM)**  
**605-037 (64 MM) - 605-023 (73 MM)**

Label holder in PVC, with or without adhesive.  
 Standard colours: transparent and white.  
 Always cut to size.

◎ **605-143 - 605-032**

Label holder in PVC, with or without adhesive.  
 Standard colour: white.  
 Always cut to size.



◎ **605-038 - 605-033**

Label holder in PVC, with or without adhesive.  
 Standard colours: transparent (26 mm H) and white (39 mm H).  
 Always cut to size.

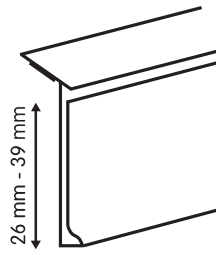

02

◎ **605-106 - 605-108**

Label holder in PVC for glass shelf, with or without adhesive.  
 Standard colour: transparent.  
 Always cut to size.

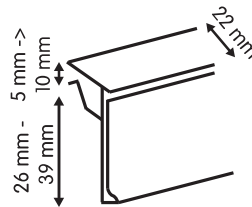

◎ **605-100 (26 MM) - 605-040 (39 MM)**

Label holder in PVC for wire basket or glass shelf, with or without adhesive.  
 Standard colours: transparent (26 mm H - 39 mm H) and white (26 mm H).  
 Always cut to size.

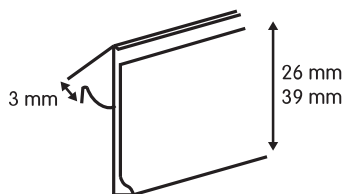

◎ **605-101**

Round label holder in white PVC, with or without adhesive.  
 Always cut to size.

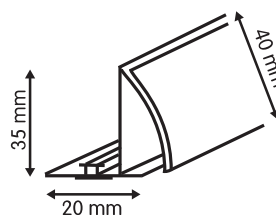

**SHELF FITTING ACCESSORIES**  
**LABEL HOLDERS**

02

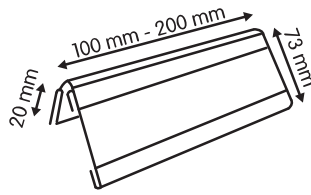

◎ **605-043**

Label holder in transparent PVC, with or without adhesive.  
 Hinges for easy access to products by customers.  
 Always cut to size.

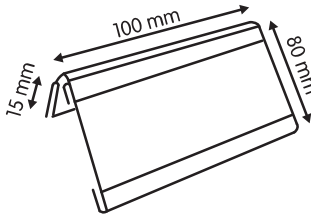

◎ **605-069**

**NEW**

Label holder in transparent PVC, with or without adhesive.  
 Hinges for easy access to products by customers.

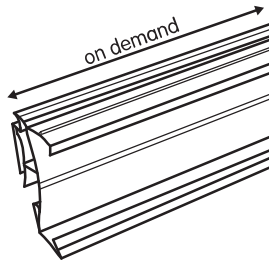

◎ **605-070**

**NEW**

White plastic data strip for electronic pricing.

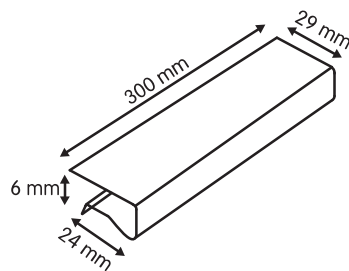

◎ **605-071**

**NEW**

Transparent plastic protection strip for glass shelves.

25

© 601-134

White polypropylene hang-strip with 12 clips and an integral header.

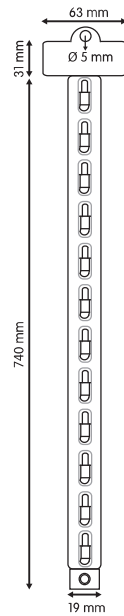

02

© 601-132 - 601-133

White polypropylene hang-strip with 6 clips (ref: 601-133) and 1 header (ref: 601-132).  
Self assembly.

601-132

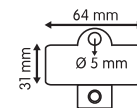

601-133

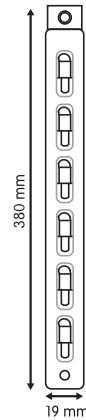

© 601-367

**NEW**

White polypropylene hang-strip with 2 suction cups (ref: 602-054) and 1 header.

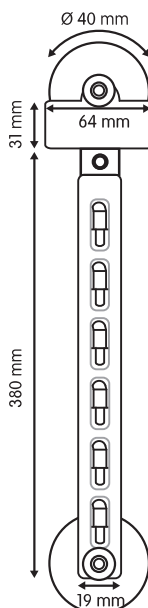

**SHELF FITTING ACCESSORIES**  
**HANG-STRIPS**

02

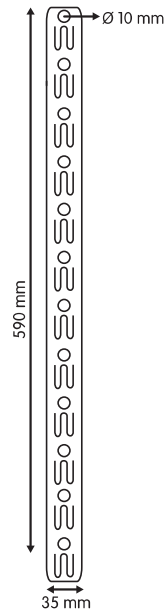

◎ **601-234**

Transparent polypropylene hang-strip with 12 hooks. Available in 500 µ or 630 µ.

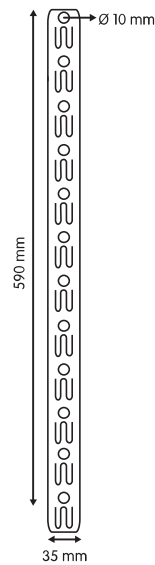

◎ **601-237**

Transparent polypropylene hang-strip on roll. Available in 500 µ or 630 µ.

500 µ: 2.000 hooks/roll  
 630 µ: 1.500 hooks/roll

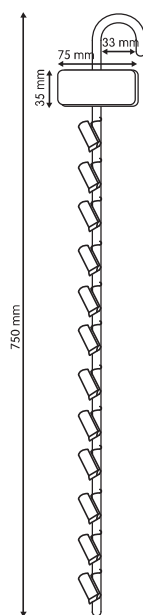

◎ **601-127**

Metal hang-strip with 12 spring clips and integral header and hook.

© **601-338**

Transparent polypropylene hang-strip with 12 hooks and integral header, foldable.

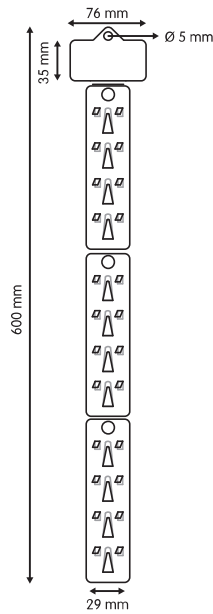

© **601-140**

Transparent polypropylene hang-strip (500  $\mu$ ) with 12 hooks and integral header.

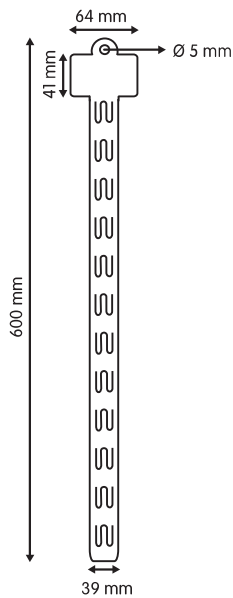

© **601-100**

Transparent polypropylene hang-strip (800  $\mu$ ) with 12 hooks and integral large header.

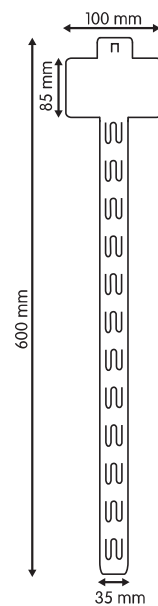

**SHELF FITTING ACCESSORIES**  
**HANG-STRIPS**

02

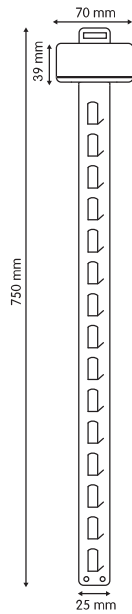

◎ **601-128**

Metal hang-strip with 15 hooks, integral header and integral hanger.  
 Colours: white - black.



**601-170**  
 (2 mm)

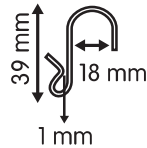

◎ **601-170 - 601-232**

Metal hook to secure hang-strip onto shelves.

**601-232**  
 (2.5 mm)

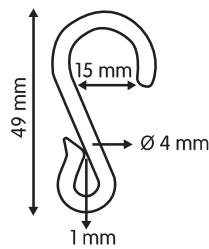
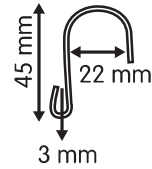

Ø 4 mm

◎ **601-254**

White nylon hook to secure hang-strip onto shelves.



- ◎ **612-008 (25 MM)**  
**612-011 (50 MM)**

**NEW**

Pusher system.  
Widths: 25 mm - 50 mm.  
Newton: 3N - 6N - 9N.  
Lengths: cut to size.

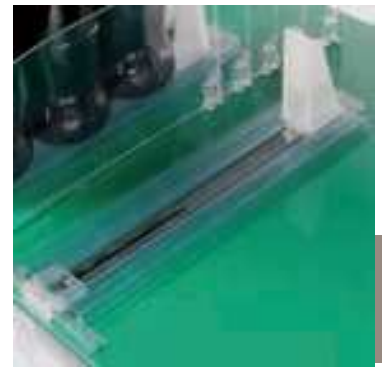
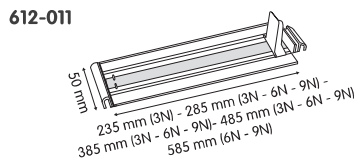
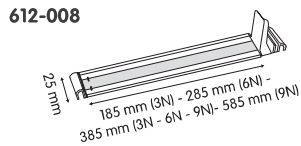

**02**

- ◎ **612-003**

**NEW**

Transparent plastic adhesive T-rail.

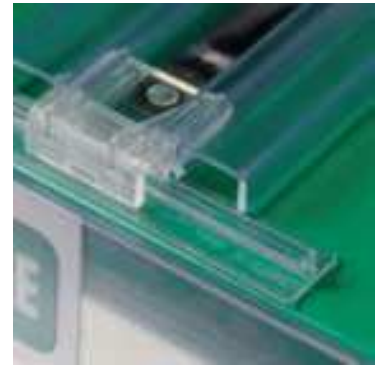
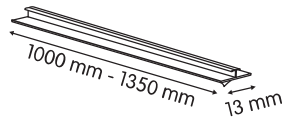

- ◎ **612-004**

**NEW**

Transparent plastic adhesive T-rail with front.

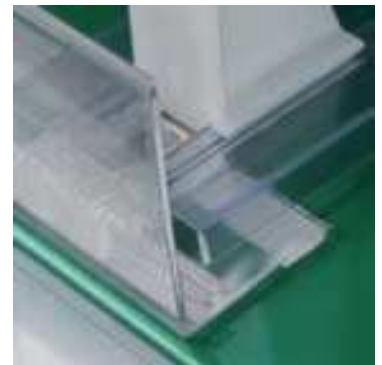
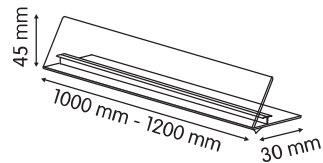

- ◎ **612-005 - 612-013**

**NEW**

Transparent plastic back support.

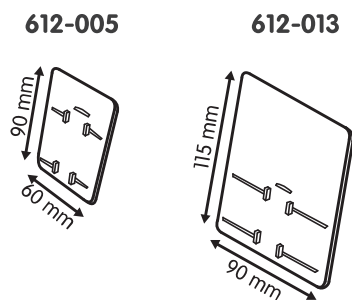

- ◎ **612-006 - 612-009**

**NEW**

Transparent plastic adjustable shelf divider.

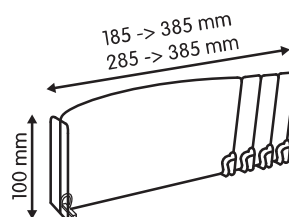

**TICKET ACCESSORIES**  
ATTACHMENTS

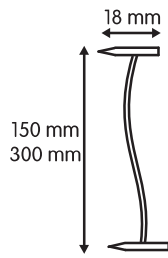

- **200-038 (150 MM)**  
**200-039 (300 MM)**

Single elastic cord with metal 'T'-end at both ends.  
Different standard colours.  
Standard lengths available from stock.  
Custom lengths can be cut to order.

03

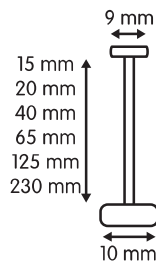

- **200-041 (15 MM) - 200-042 (20 MM)**  
**200-044 (40 MM) - 200-045 (65 MM)**  
**200-040 (125 MM) - 200-043 (230 MM)**

Natural nylon or polypropylene tag attachment.  
For use with tagging gun (ref: 200-017).

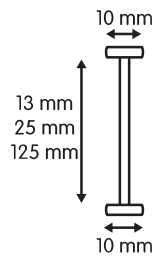

- **200-047 (13 MM) - 200-048 (25 MM)**  
**200-046 (125 MM)**

Natural nylon tag attachment.  
For use with tagging gun (ref: 200-017).

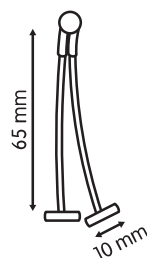

- **200-049**

Natural nylon tag attachment.  
For use with tagging gun (ref: 200-017).

◎ **200-050**

Natural nylon tag attachment.  
For use with tagging gun (ref: 200-017).

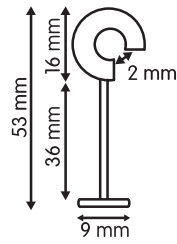

◎ **200-017 - 200-019**

Tagging gun for normal fabrics  
(brand: Dennison).  
Optional: needles (ref: 200-019).

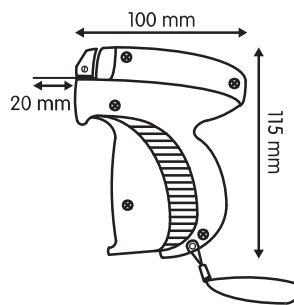

03

◎ **611-078 (75 MM) - 611-079 (125 MM)  
611-080 (225 MM)**

Natural polypropylene security loops.

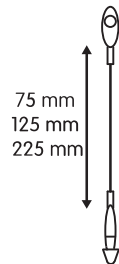

◎ **200-002 (125 MM) - 200-007 (225 MM)**

Natural nylon or polypropylene security loops.

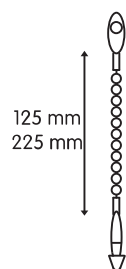

**TICKET ACCESSORIES**  
**ATTACHMENTS**

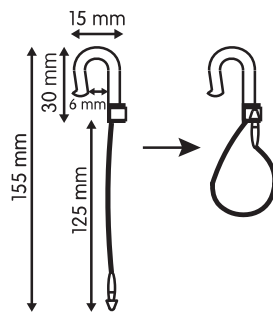

◎ **200-014**

Natural polypropylene security loop with suspension hook.

**03**

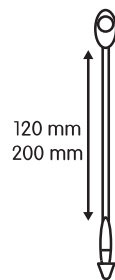

◎ **200-036**

Textile security loop.  
Standard colours: white or black.

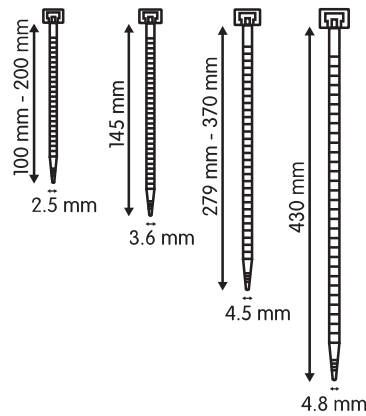

◎ **200-009 (100 MM) - 200-010 (145 MM)**  
**200-011 (200 MM) - 200-013 (279 MM)**  
**200-200 (370 MM) - 200-033 (430 MM)**

Neutral or black nylon cable tie.

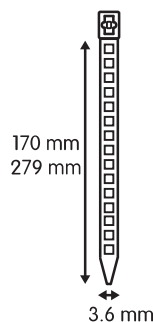

◎ **200-034 (170 MM) - 200-035 (279 MM)**

Neutral nylon cable tie.

© 200-020



Metal security loop with screw closure.

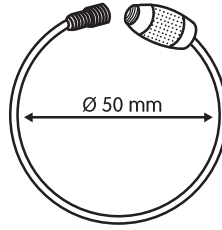

© 611-074

Loop in natural plastic.

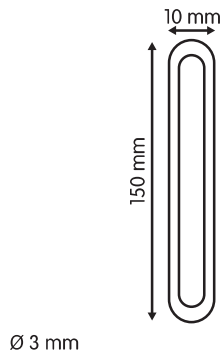

03

© 611-061

Promo bottle ring, with fix diameter, in natural or black polypropylene.

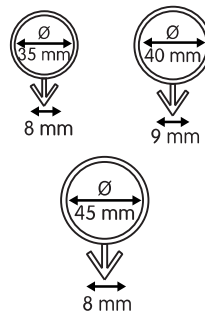

© 605-133

Promo bottle ring, with flexible diameter, in natural or black polypropylene.

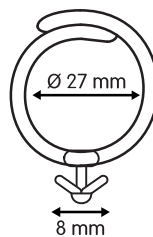

© 611-242

Hanging clip in flexible plastic for wire bin.

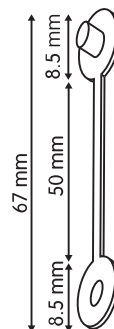



**TICKET ACCESSORIES**  
**CARD HOLDERS**

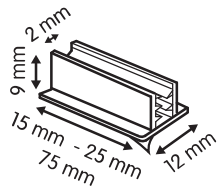

**603-045:** 15 mm    **603-003:** 25 mm  
**603-004:** 75 mm

◎ **603-045 - 603-003 - 603-004**

Clear PVC (supergrip) card holder with foam adhesive.

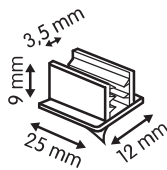

◎ **603-066** **NEW**

Clear PVC (supergrip) card holder with foam adhesive.

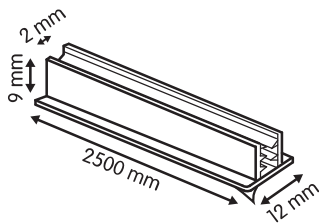

◎ **603-054**

Clear PVC (supergrip) card holder with foam adhesive.

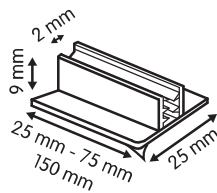

**603-005:** 25 mm    **603-105:** 150 mm  
**603-006:** 75 mm

◎ **603-005 - 603-006 - 603-105**

Clear PVC (supergrip) card holder with foam adhesive.

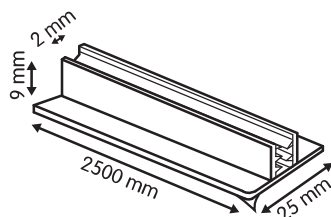

◎ **603-048**

Clear PVC (supergrip) card holder with foam adhesive.



◎ **603-006 - 603-100**

Clear PVC (supergrip) card holder with foam adhesive.

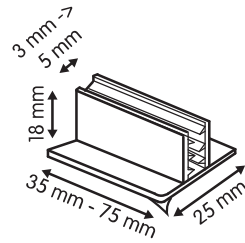

**603-006:** 75 mm    **603-100:** 35 mm



◎ **603-104 - 603-102**

Clear PVC (supergrip) card holder with magnet.

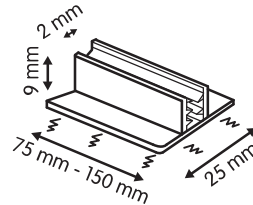

**603-104:** 75 mm    **603-102:** 150 mm



03

◎ **605-013 - 605-123**

Square magnet with or without supergrip (ref: 603-005 or 603-100) attached.

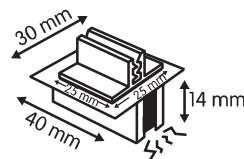

**605-013:** cap: max 2 mm  
**605-123:** cap: 3 -> 5 mm



◎ **603-007 - 603-008**

Clear PVC (supergrip) card holder with foam adhesive.

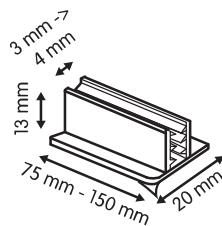

**603-007:** 75 mm    **603-008:** 150 mm



◎ **603-043**

Clear PVC (supergrip) card holder without adhesive.

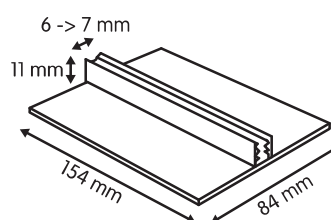

**TICKET ACCESSORIES**  
**CARD HOLDERS**

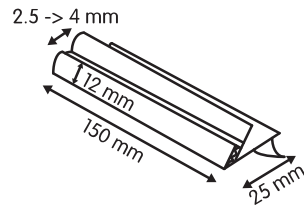

◎ **603-058**

Clear PVC (supergrip) card holder with foam adhesive.

**03**

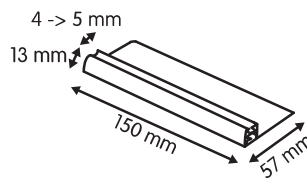

◎ **603-046**

Clear PVC (supergrip) card holder without adhesive

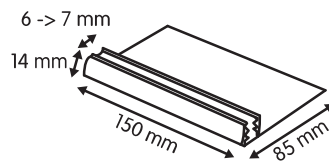

◎ **603-047**

Clear PVC (supergrip) card holder without adhesive

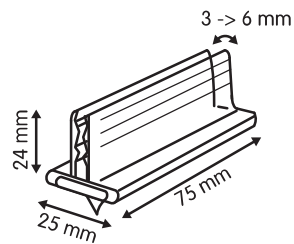

◎ **603-060**

Clear PVC (supergrip) card holder with foam adhesive.

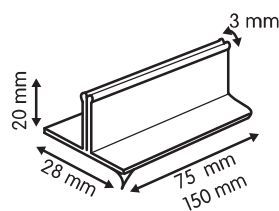

◎ **603-059 - 603-056**

Clear PVC (supergrip) card holder with foam adhesive.

**603-059:75 mm 603-056:150 mm**

© 603-067



Clear PVC (supergrip) card holder without adhesive.

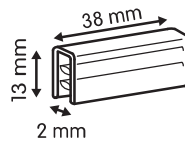

© 603-009 - 603-010 - 603-011

Clear PVC (supergrip) card holder with foam adhesive.

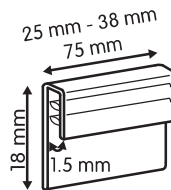

603-009: 25 mm    603-011: 75 mm  
603-010: 38 mm



03

© 603-012 - 603-013

Clear PVC hinged (supergrip) card holder with foam adhesive. Hinges for easy access to products by customers.

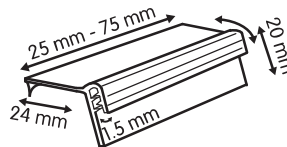

603-012: 25 mm    603-013: 75 mm



© 603-068



Clear PVC hinged (supergrip) card holder without adhesive. Hinges for easy access to products by customers.

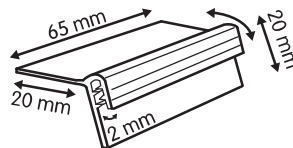

© 603-014

Clear PVC hinged (supergrip) card holder. Hinges for easy access to products by customers.

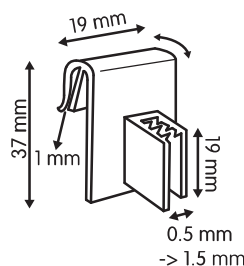

**TICKET ACCESSORIES**  
**CARD HOLDERS**

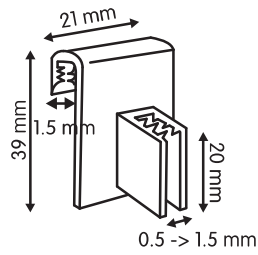

◎ **603-015**

Clear PVC (supergrip) card holder.  
Fits any label holder.

**03**

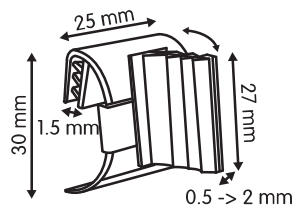

◎ **603-050**

Clear PVC (supergrip) round card holder.  
Fits any label holder.

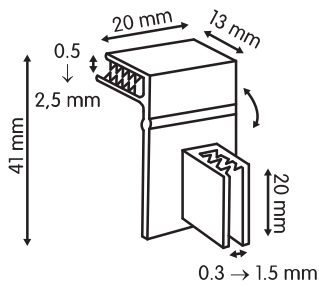

◎ **603-035**

Clear PVC hinged (supergrip) card holder.  
Hinges for easy access to products by customers.

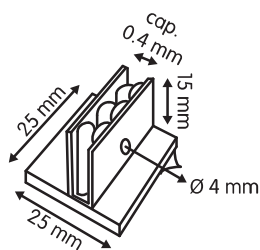

◎ **602-012**

Multifunctional white polypropylene card holder with hole and foam adhesive.

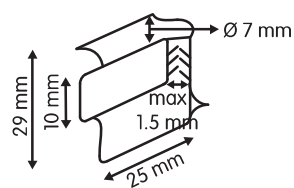

◎ **603-057**

Clear PVC (supergrip) pen holder with adhesive.

◎ **602-006**

White polypropylene pen clip with foam adhesive.

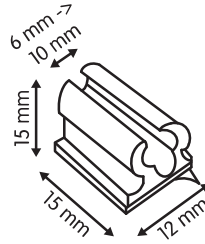

◎ **602-062**

Metallic pen clip with foam adhesive. The clip can be stretched and adapted to different sizes of pens.

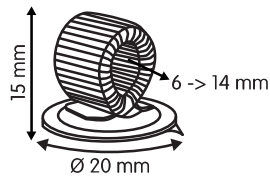

◎ **611-235**

Clear plastic card holder for wire basket.

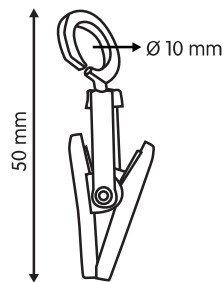

◎ **611-233**

White plastic card holder for wire basket with foam adhesive.

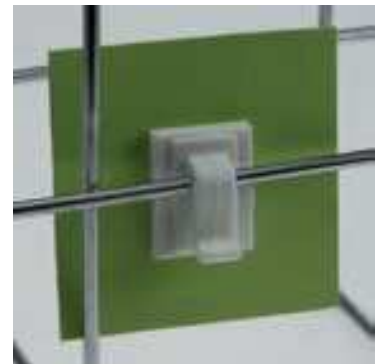
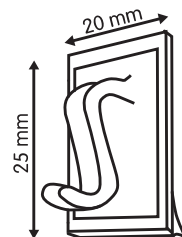

◎ **611-234**

White plastic card holder for wire basket with foam adhesive.

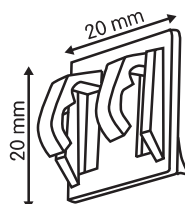

03

TICKET ACCESSORIES  
CARD HOLDERS

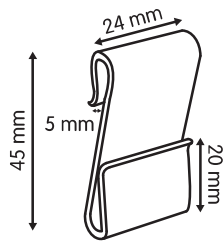

◎ 601-118



White PVC hanging clip for wire basket.

03

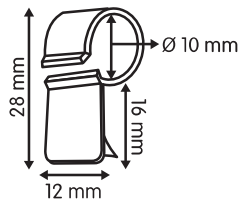

◎ 603-103

Clear PVC card holder with foam adhesive for wire basket.

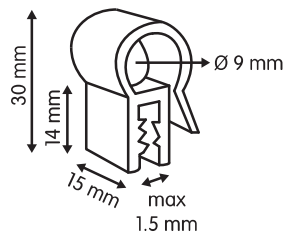

◎ 603-017

Clear PVC (supergrip) card holder for wire basket.

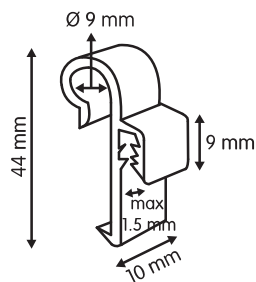

◎ 603-018

Clear PVC (supergrip) card holder for wire basket.



◎ 603-021

Clear PVC (supergrip) card holder for wire basket.

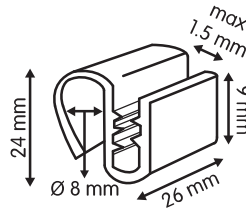

◎ 603-022

Clear PVC (supergrip) card holder for wire basket.

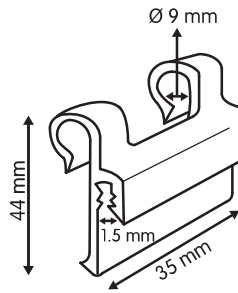

03

◎ 603-024

Clear PVC (supergrip) card holder for wire bin.

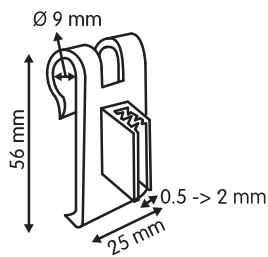

◎ 603-034

Clear PVC (supergrip) card holder for wire basket.

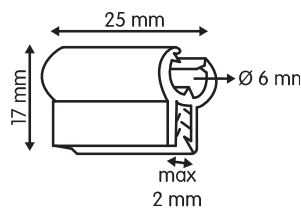

◎ 603-108



Clear PVC (supergrip) card holder for wire basket.

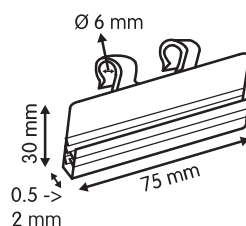

**TICKET ACCESSORIES**  
**CARD HOLDERS**

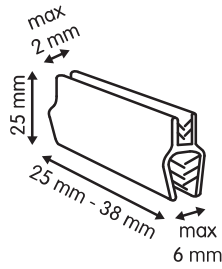

◎ **603-040**

Clear PVC double (supergrip) card holder.

**03**

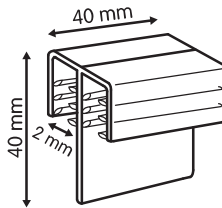
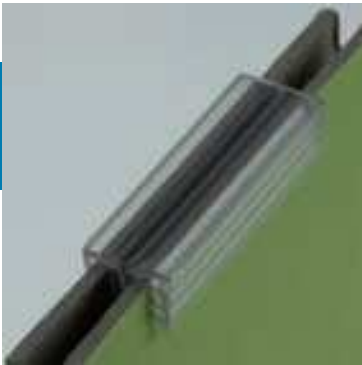

◎ **603-063**

**NEW**

Clear PVC double (supergrip) card holder.

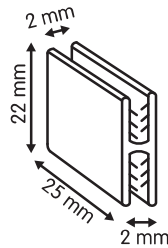

◎ **603-025**

Clear PVC double (supergrip) card holder.

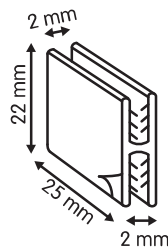

◎ **603-101**

Clear PVC double (supergrip) card holder with foam adhesive.

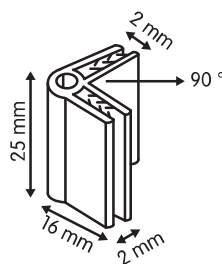
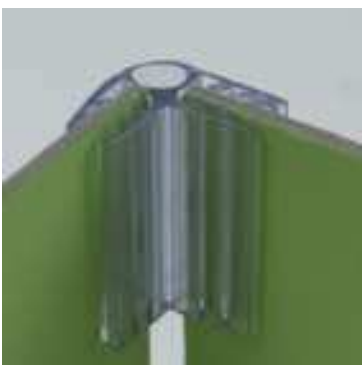

◎ **603-026**

Clear PVC (supergrip) card holder for creating 2-way display.

◎ **603-027**

Clear PVC (supergrip) card holder for creating 2-way display.

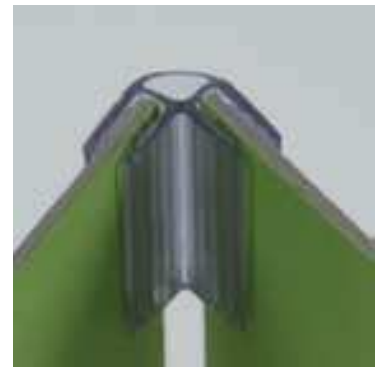
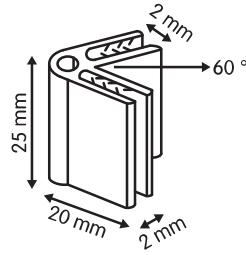

◎ **603-028**

Clear PVC (supergrip) card holder for creating 3-way display.

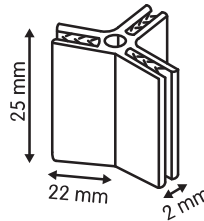

03

◎ **603-029**

Clear PVC (supergrip) card holder for creating 4-way display.

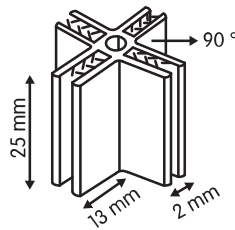

◎ **603-041**

Clear PVC hinged (supergrip) card holder for creating 2-way display.

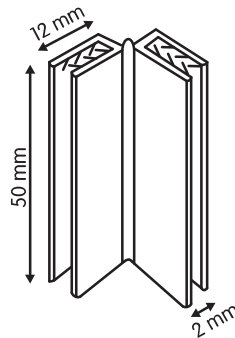

◎ **603-030**

Clear PVC (supergrip) card holder with suction cup.

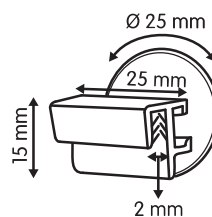

TICKET ACCESSORIES  
CARD HOLDERS

03

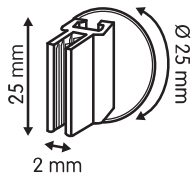

◎ 603-031

Clear PVC (supergrip) card holder with suction cup.

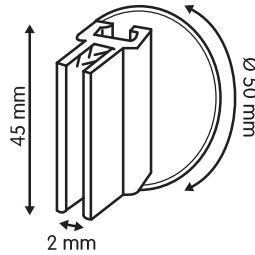

◎ 603-064 **NEW**

Clear PVC (supergrip) card holder with suction cup.

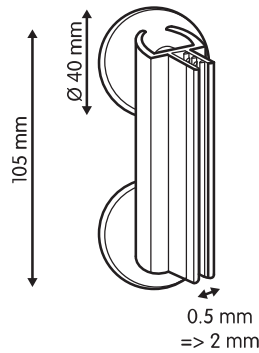

◎ 603-065 **NEW**

Clear PVC (supergrip) card holder with 2 suction cups (ref: SUC 2/ZH).  
Self assembly.

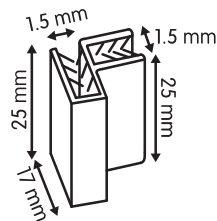

◎ 603-042

Clear PVC 90° reverse double (supergrip) card holder.

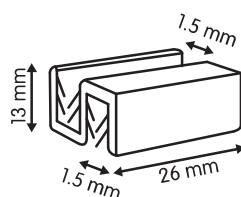

◎ 603-032

Clear PVC 180° reverse double (supergrip) card holder.

◎ **603-033**

Clear PVC hinged (supergrip) card holder with foam adhesive.

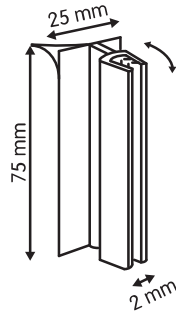

◎ **603-072**



Clear PVC hinged (supergrip) card holder with foam adhesive.

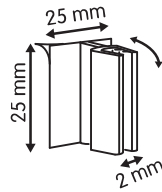

03

◎ **603-044**

Clear PVC hinged card holder with foam adhesive. Can be used in combination with label holder.

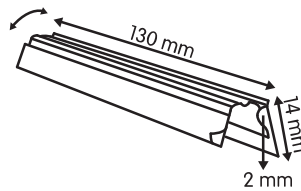

◎ **605-014**

Swinger.  
Suction cup + metal arm (length: 15 cm) + (supergrip) card holder.

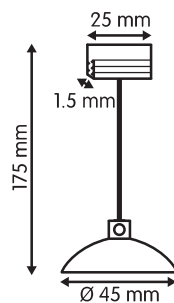

**TICKET ACCESSORIES**  
TICKET HOLDERS

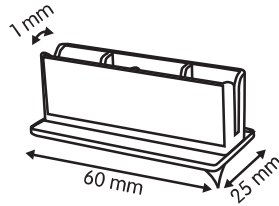

◎ **605-158**

Clear polystyrene ticket stand with adhesive base.

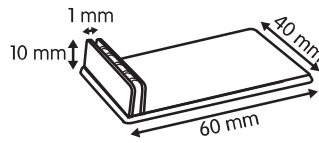

◎ **605-042**

Clear polystyrene ticket stand.

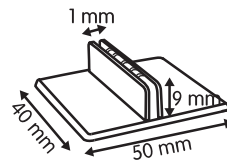

◎ **605-159**

Clear polystyrene ticket stand.

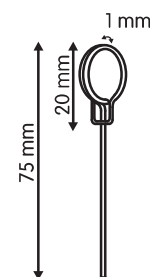

◎ **603-051**

Stainless steel (Nirosta) pin ticket holder. Can be used with food.

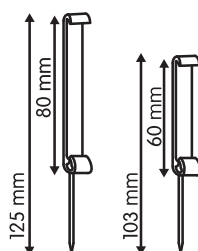

◎ **603-052 (60 MM)**  
**603-053 (80 MM)**

White plastic pin ticket holder.



◎ **603-061**

Clear plastic double clip.

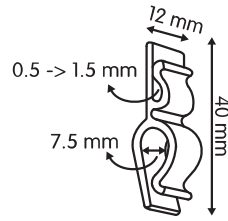

◎ **605-132**

White nylon ticket holder, adjustable in 4 positions.

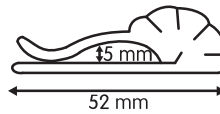

03

◎ **605-031**

Clear polystyrene ticket holder with clip at one end and suction cup at the other side, adjustable.

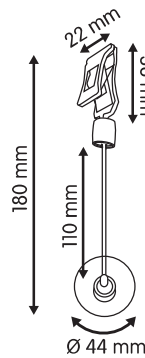

◎ **605-024**

Clear polystyrene ticket holder with small double clip, adjustable.

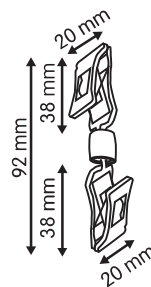

◎ **605-030**

Clear polystyrene ticket holder with small double clip, adjustable.

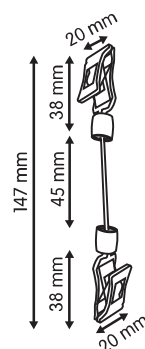

## TICKET ACCESSORIES

### TICKET HOLDERS

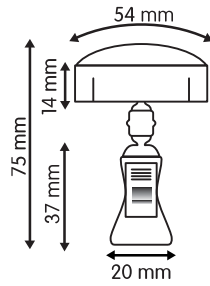

#### ◎ 605-045

Clear polystyrene ticket holder with small clip at one end and ticket holder at the other side, adjustable.

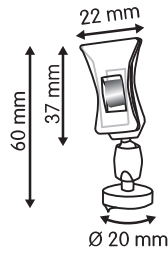

#### ◎ 605-028

Clear polystyrene ticket holder with adhesive base.

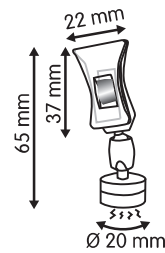

#### ◎ 605-029

Clear polystyrene ticket holder with magnetic base.

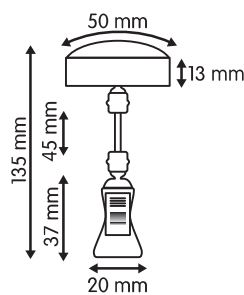

#### ◎ 605-140

Clear polystyrene ticket holder with small clip at one end and a ticket holder on the other, adjustable.

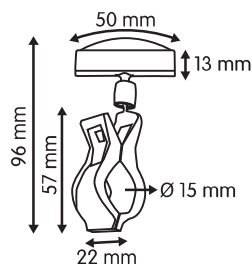

#### ◎ 605-146

Clear polystyrene ticket holder with large clip at one end and a ticket holder on the other, adjustable.

◎ 605-147

Clear polystyrene ticket holder with large clip at one end and a ticket holder on the other, adjustable.

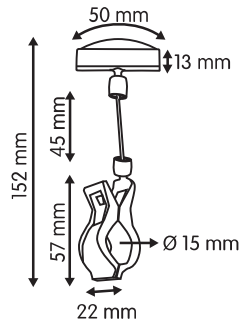

◎ 605-049

Clear polystyrene ticket holder with large clip at one end and a gripper on the other, adjustable.

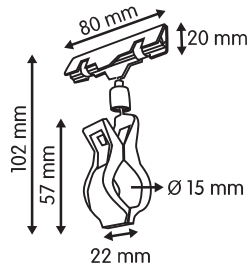

◎ 605-148

Clear polystyrene ticket holder with large clip at one end and a gripper on the other, adjustable.

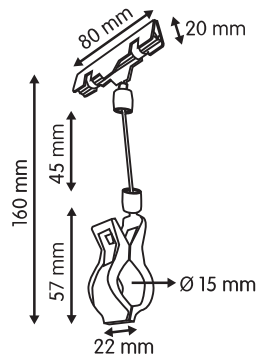

◎ 605-149

Clear polystyrene ticket holder with magnet at one end and a small clip on the other, adjustable.

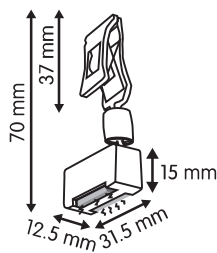

◎ 605-150

Clear polystyrene ticket holder with magnet at one end and a ticket holder on the other, adjustable.

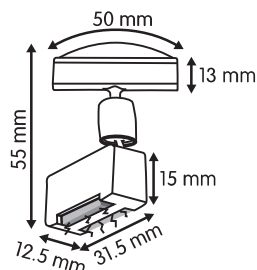

03

**TICKET ACCESSORIES**  
TICKET HOLDERS

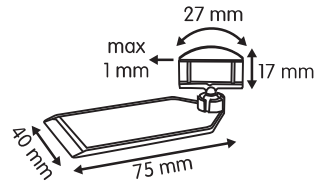

◎ **605-050**

Clear polystyrene ticket stand.  
Self assembly.

03

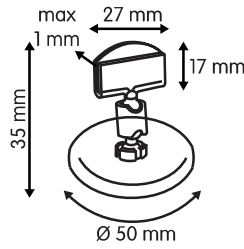

◎ **605-051**

Clear polystyrene ticket stand.  
Self assembly.

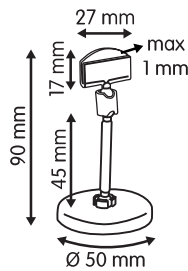

◎ **605-052**

Clear polystyrene ticket stand.  
Self assembly.

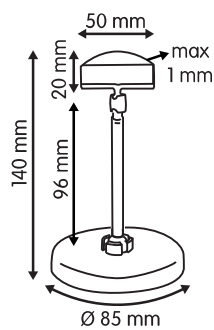

◎ **605-111**

Clear polystyrene ticket stand.  
Self assembly.

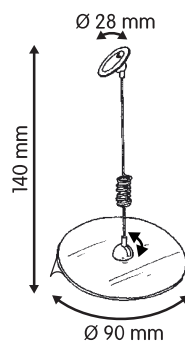

◎ **611-081**

Swinger.  
Round base plate (white) + stem (length: 16 cm) + adhesive dot.

You can create your own configuration of ticket holder by selecting the components that match your requirements. Options include bases, grippers, magnets and card holders.

All you have to do is choose one base, one stem and one card holder and leave the rest to us.

◎ **605-151**

Clear polystyrene small gripper.

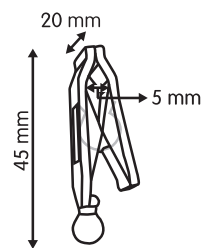

◎ **605-152**

Clear polystyrene large gripper.

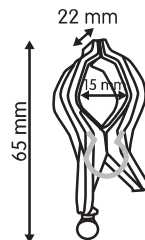

◎ **605-153**

White polystyrene magnet.

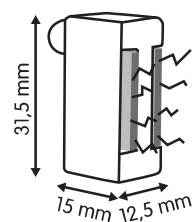

TICKET ACCESSORIES  
TICKET HOLDERS

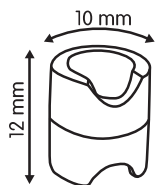

◎ **605-154**

White polystyrene connector.

03



◎ **605-155**

Clear polystyrene stem.

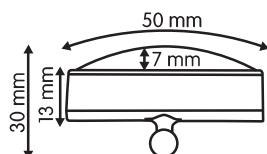

◎ **605-156**

Clear polystyrene small ticket holder.

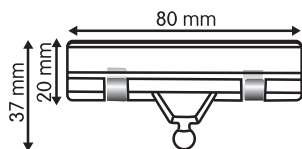

◎ **605-157**

Clear polystyrene large gripper.



◎ **602-010**

Clear vinyl suction cup with nipple.

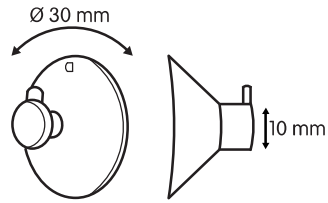

◎ **602-011**

Clear vinyl suction cup with metal hook.

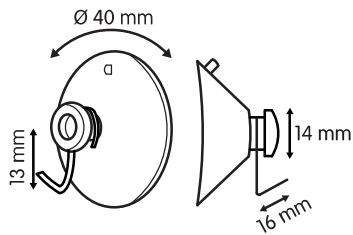

03

◎ **602-024**

Clear vinyl suction cup.

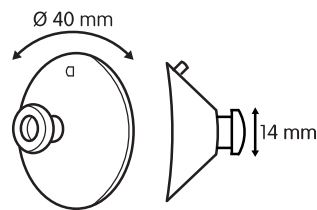

◎ **602-022**

Clear vinyl suction cup with thumb tack.

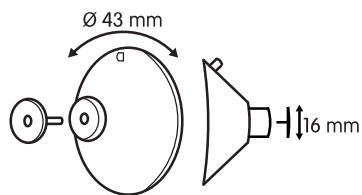

◎ **602-054**

Clear vinyl suction cup with white screw.  
Self assembly.

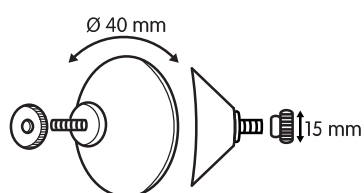

**TICKET ACCESSORIES**  
**SUCTION CUPS**

03

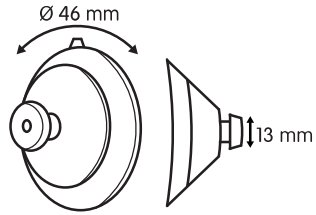

◎ **602-019**

Clear vinyl double suction cup.

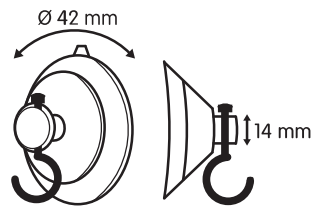

◎ **602-023**

Clear vinyl double suction cup with swivel hook.

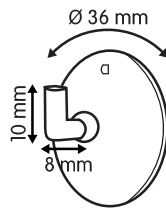

◎ **602-091**

Clear vinyl suction cup with hook.

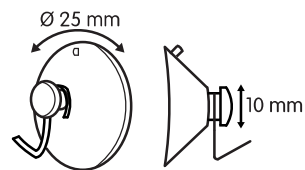

◎ **602-032**

Clear vinyl suction cup with metal hook.

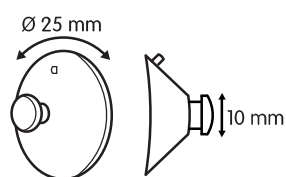

◎ **602-031**

Clear vinyl suction cup.

© 602-030 **NEW**

Clear vinyl two-way suction cup.

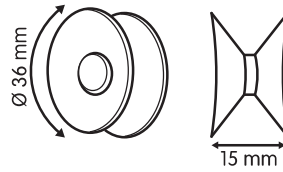

© 602-028 **NEW**

Clear vinyl double suction cup with hanging hole.

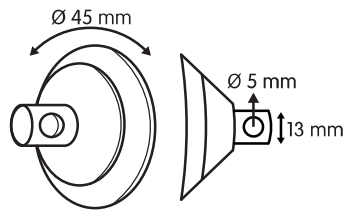

03

© 602-108

Vinyl suction cup with white hook and screw for fixing heavy objects. Large suction force is created by screw when tightened after the suction cup is attached to the window. Suction cup can also be used without the white hook.

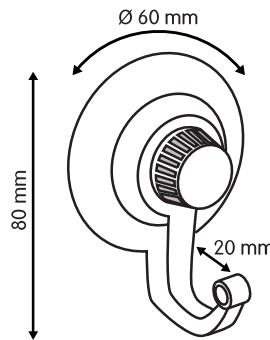

© 602-029 **NEW**

Vinyl suction cup with black hook and screw for fixing heavy objects.

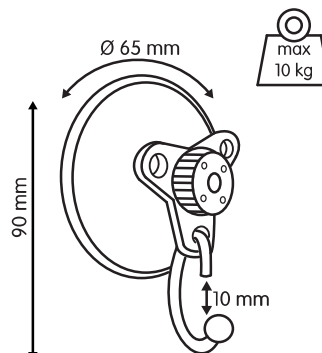

**TICKET ACCESSORIES**  
**BADGE ACCESSORIES**

03

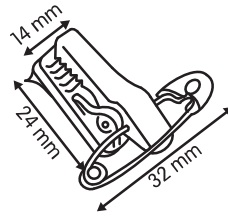

◎ **611-115**

Adhesive metal badge clip with metal safety pin.

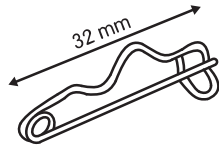

◎ **611-116**

Metal safety pin for badges.

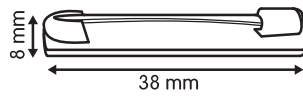

◎ **611-117**

White or black plastic adhesive badge pin.

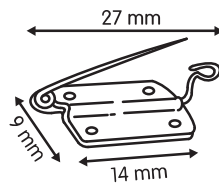

◎ **611-118**

Metal safety pin for fixing with hot-melt glue.

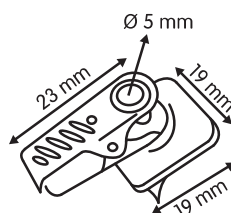

◎ **611-119**

Adhesive metal badge clip.

◎ 611-164

Metal badge magnet with self adhesive base plate.

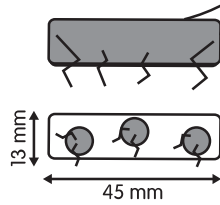

◎ 611-012

Metal clip with hole for attaching a lanyard.

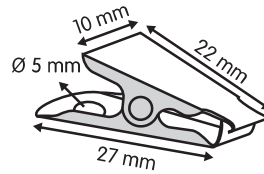

◎ 611-223

Metal badge clip with transparent plastic attachment loop.

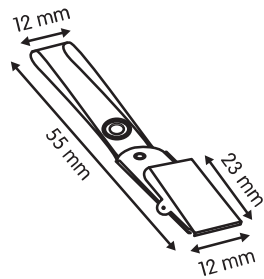

◎ 611-224

White plastic badge clip, with clear plastic attachment loop.

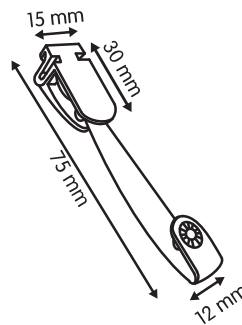

◎ 611-121

Clear PVC badge holder with oval slot in top (without clip).

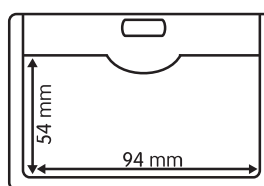

03

**TICKET ACCESSORIES**  
**BADGE ACCESSORIES**

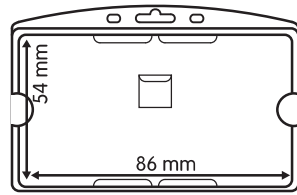

◎ **611-217**



Clear rigid polypropylene badge holder with 'euroslot' in top.

◎ **602-085**

Jojo retractable badge holder complete with metal clip on the rear.  
 Colours: white, grey or transparent blue.

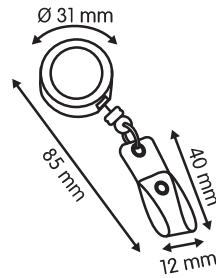

03



◎ **611-122**

Clear plastic badge holder with clip and pin.

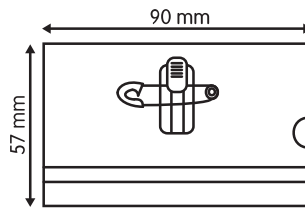

◎ **611-165**

Clear plastic badge holder with strong magnet.

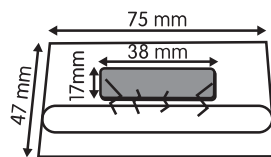

**611-127**

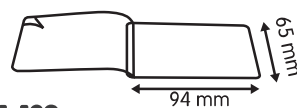

**611-129**

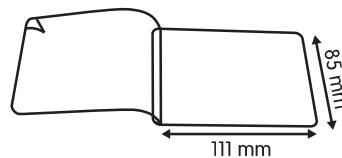

◎ **611-127 - 611-129**

Clear polypropylene self-laminating badge holder for business cards, pictures, often used documents,....  
 Place your card accurately and roll the adhesive foil over it.



◎ **606-304 (A5) - 606-307 (1/3 A4)**  
**606-305 (A6V)**

Clear PVC leaflet dispenser (round corners) with adhesive tape and 2 hanging holes. Delivered flat. Made to order from 500 pcs.

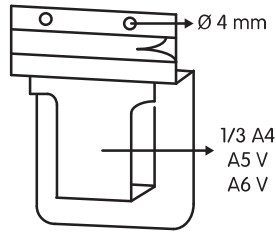

◎ **606-144**

Clear (recyclable) polystyrene leaflet dispenser with 1 hanging hole. Free standing or wall mounted.

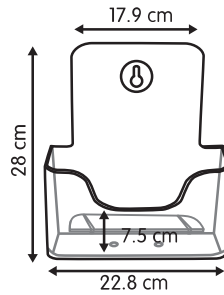

◎ **606-147**

Clear (recyclable) polystyrene leaflet dispenser with 1 hanging hole. Free standing or wall mounted.

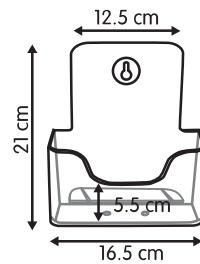

◎ **606-148**

Clear (recyclable) polystyrene leaflet dispenser with 1 hanging hole. Free standing or wall mounted.

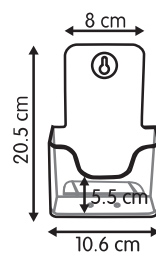

◎ **606-174**

Clear (recyclable) polystyrene leaflet dispenser without hanging hole. Free standing only.

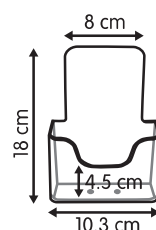

04

## LEAFLET DISPENSERS

### LEAFLET DISPENSERS

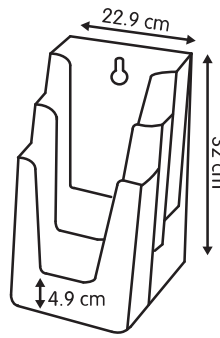

#### ◎ 606-149

Clear (recyclable) polystyrene 3 bay leaflet dispenser with hanging hole. Free standing or wall mounted.

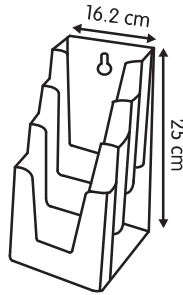

#### ◎ 606-150

Clear (recyclable) polystyrene 4 bay leaflet dispenser with hanging hole. Free standing or wall mounted.

04

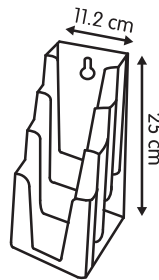

#### ◎ 606-151

Clear (recyclable) polystyrene 4 bay leaflet dispenser with hanging hole. Free standing or wall mounted.

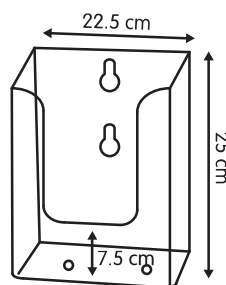

#### ◎ 606-145

Clear (recyclable) polystyrene wall mounted leaflet dispenser with 2 hanging holes.

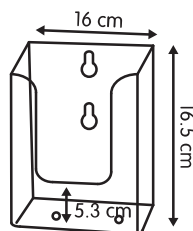

#### ◎ 606-159

Clear (recyclable) polystyrene wall mounted leaflet dispenser with 2 hanging holes.

◎ 606-190

Clear (recyclable) polystyrene wall mounted leaflet dispenser with 2 hanging holes.

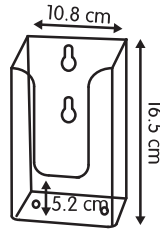

◎ 606-206

Clear (recyclable) polystyrene wall mounted leaflet dispenser with 4 hanging holes. Leaflet dispensers can be attached above or next to each other. 1 set = 4 leaflet dispensers.

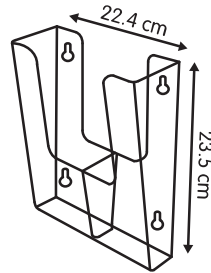

◎ 606-207

Clear (recyclable) polystyrene wall mounted leaflet dispenser with 4 perforations. Leaflet dispensers can be attached above or next to each other. 1 set = 4 leaflet dispensers.

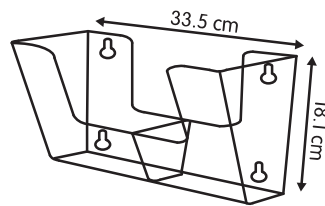

◎ 606-208

Clear (recyclable) polystyrene leaflet dispenser without hanging hole. Free standing only.

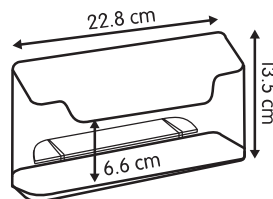

◎ 606-210

Clear (recyclable) polystyrene leaflet dispenser without hanging hole. Free standing only.

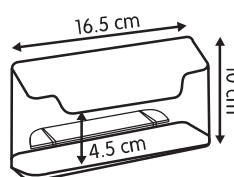

## LEAFLET DISPENSERS

### LEAFLET DISPENSERS

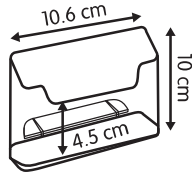

◎ **606-209**

Clear (recyclable) polystyrene leaflet dispenser without hanging hole. Free standing only.

◎ **607-082**

**NEW**

Polycarbonate info stand with acrylic leaflet dispenser. Self assembly.

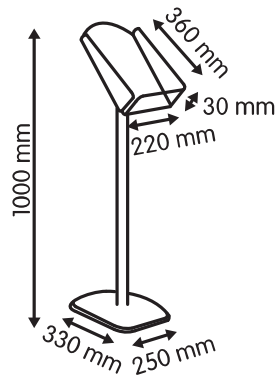

04

◎ **604-028**

**NEW**

Brochure stand with header in aluminium, leaflet dispensers in acrylic. Self assembly.

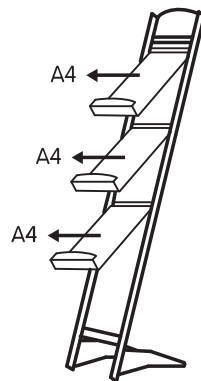

© 606-146

Clear (recyclable) polystyrene business card dispenser.

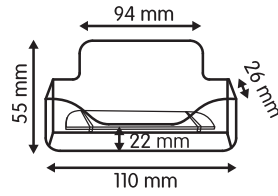

© 606-459

Clear (recyclable) polystyrene business card dispenser.

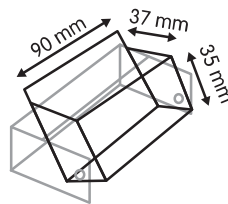

© 606-196

NEW

Clear plastic business card holder.

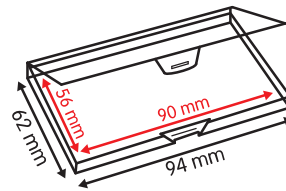

© 611-084

Clear polystyrene calendar box (size CD).

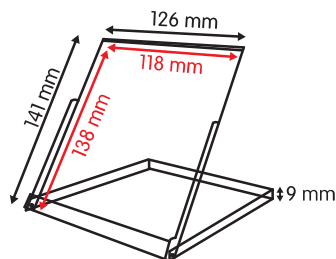

© 611-085

Clear polystyrene calendar box.

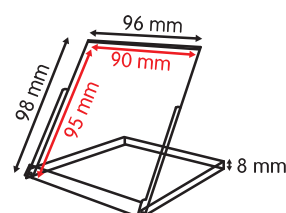

## LEAFLET DISPENSERS

### LEAFLET HOLDERS

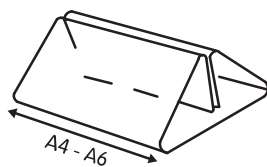

◎ **606-212 (A4) - 606-465 (A6)**

Clear PVC (1 mm) leaflet holder without impression. Free standing.  
On request in plexi.

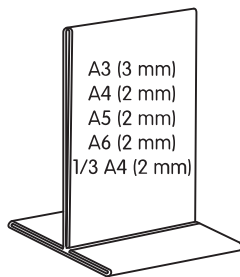

◎ **606-214 (A3) - 606-401 (A4)**  
**606-191 (A5) - 606-215 (A6)**  
**606-430 (1/3 A4)**

Clear acrylic double sided leaflet holder, with or without printing. Free standing.

04

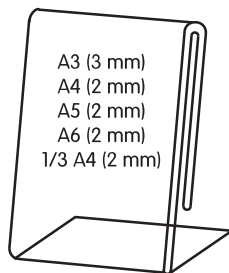
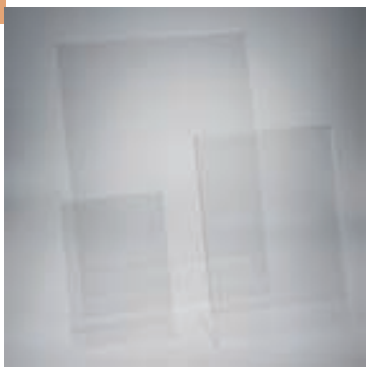

◎ **606-202 (A3) - 606-403 (A4)**  
**606-413 (A5) - 606-203 (A6)**  
**606-201 (1/3 A4)**

Clear acrylic leaflet holder, with or without printing. Free standing.

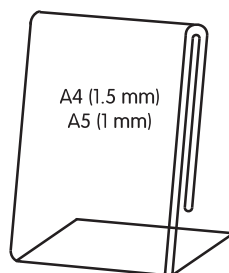

◎ **606-204 (A4) - 606-211 (A5)**

Clear PET leaflet holder, with or without printing. Free standing.

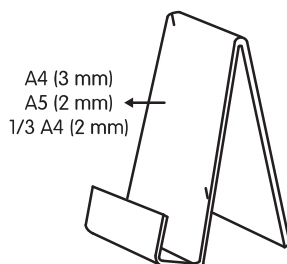

◎ **606-404 (A4) - 606-415 (A5)**  
**606-205 (1/3 A4)**

Clear acrylic leaflet holder, with or without printing. Free standing.



◎ **606-312 (A4) - 606-311 (A5)**

Clear PVC leaflet holder.  
Delivered flat.

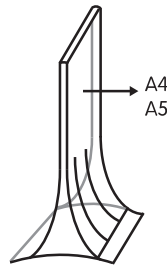

◎ **606-410 (1/3 A4) - 606-409 (A5)**

Clear acrylic leaflet holder with leaflet dispenser, with or without printing.  
Free standing.

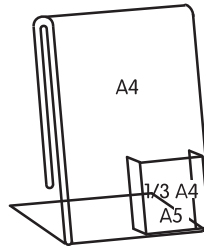

◎ **606-216 (A3) - 606-217 (A4)  
606-218 (A5)**

Clear PET wall mounted leaflet holder with  
2 hanging holes on top (open at 1 side).

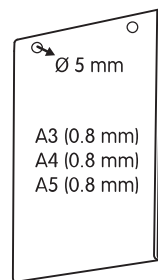

◎ **606-219**

Clear acrylic cash caddy.  
Inlay can easily be inserted and changed.  
With or without printing.

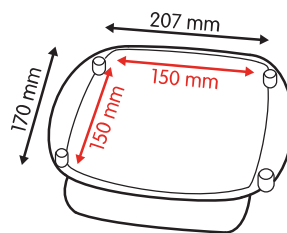

◎ **606-157 (100 MM) - 606-140 (150 MM)  
606-137 (200 MM) - 606-139 (250 MM)  
606-141 (300 MM) - 606-138 (350 MM)  
606-142 (400 MM) - 606-197 (450 MM)  
606-143 (500 MM) - 606-198 (710 MM)**

Cardboard showcard stand, with or without  
adhesive tape.

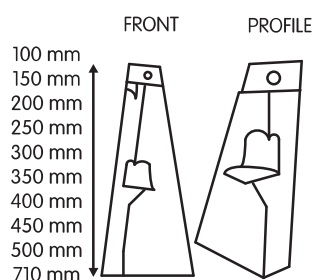

**LEAFLET DISPENSERS  
POCKETS**

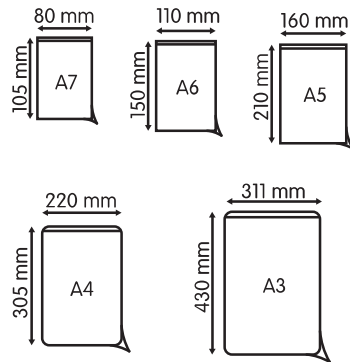

- ◎ 611-269 (A3) - 611-209 (A4)
- 611-208 (A5) - 611-147 (A6)
- 611-280 (A7)

Clear PVC pocket with adhesive.

04

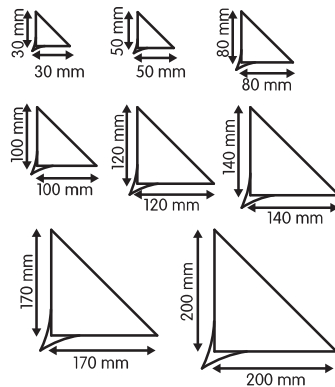

- ◎ 611-251 (30 MM) - 611-131 (50 MM)
- 611-146 (80 MM) - 611-132 (100 MM)
- 611-133 (120 MM) - 611-134 (140 MM)
- 611-135 (170 MM) - 611-136 (200 MM)

Clear PVC corners with adhesive.

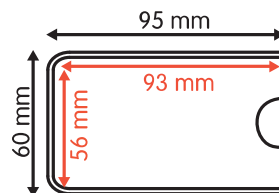

- ◎ 611-126

Clear polypropylene badge pocket with semicircular finger cut.

© 611-162

Clear polypropylene badge pocket with adhesive closure.

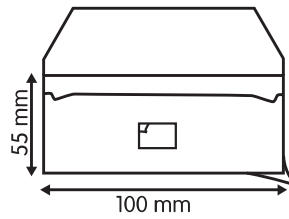

© 611-219 (A4) - 611-220 (A5)  
611-221 (A6) - 611-222 (A7)

Clear PVC pocket with hanging hole.  
No adhesive.

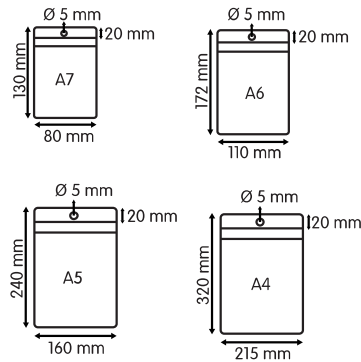

04

© 611-272 (A1) - 611-273 (A2)  
611-274 (A3) - 611-275 (A4)  
611-276 (A5) - 611-277 (A6)  
611-278 (A7) - 611-279 (A8)

Clear electrostatic pocket.  
Advantage: attaches to the window  
without adhesive!

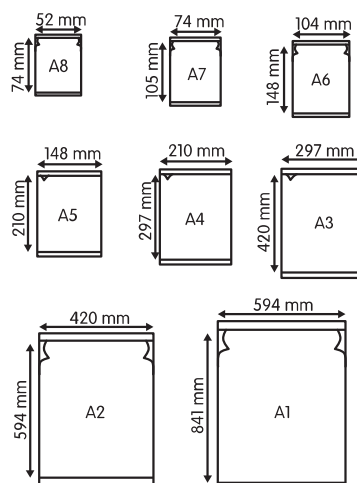

**DISPLAY ACCESSORIES**  
**DISPLAY ARMS AND ACCESSORIES**

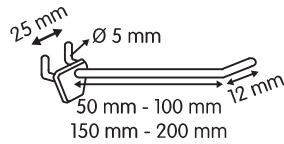

**601-210:** 50 mm    **601-204:** 150 mm  
**601-203:** 100 mm    **601-205:** 200 mm

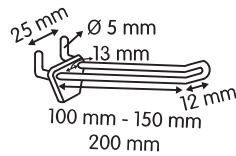

**601-206:** 100 mm    **601-208:** 200 mm  
**601-207:** 150 mm

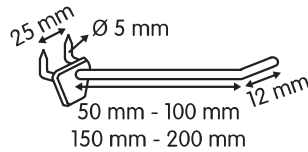

◎ **601-210 - 601-203 - 601-204**  
**601-205**

White ABS single pegboard and slatwall display arm.

◎ **601-206 - 601-207 - 601-208**

White ABS double pegboard and slatwall display arm.

◎ **601-209 (50 MM) - 601-252 (100 MM)**  
**601-211 (150 MM) - 611-212 (200 MM)**

White ABS single display arm with 2 spikes.

◎ **601-201 (100 MM) - 601-213 (150 MM)**  
**601-214 (200 MM)**

White ABS double display arm with 2 spikes.

◎ **601-230**

White plastic single arm with adhesive.

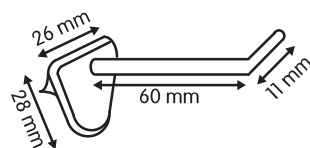

◎ **601-337**

White ABS single display arm, foldable.

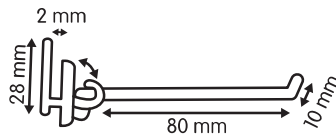

◎ **601-111**

White plastic single display arm.  
 Can be mounted over the top of a display or into a slotwall.

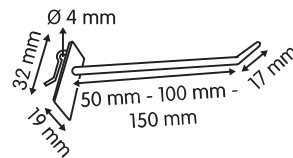

◎ **601-117**

White plastic double display arm.  
 Can be mounted over the top of a display or into a slotwall.

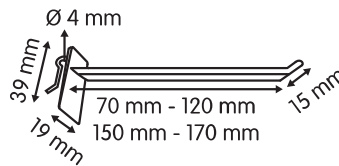

◎ **601-120**

White plastic single slotwall display arm.

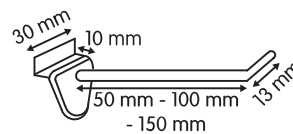

◎ **601-129 (100 MM) - 601-141 (140 MM)**  
**601-142 (200 MM) - 601-148 (300 MM)**  
**601-153 (400 MM)**

Single metal pegboard display arm with rounded top.  
 Hole perforation: 30 mm  
 (25 mm on request).

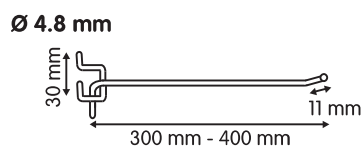
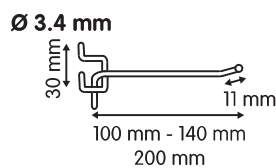

**05**

**DISPLAY ACCESSORIES**  
**DISPLAY ARMS AND ACCESSORIES**

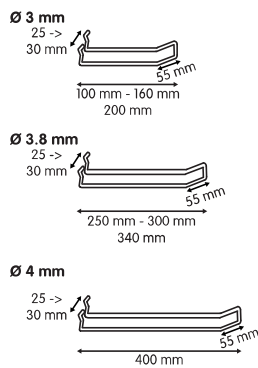

- ◎ **601-154 (100 MM) - 601-168 (160 MM)**
- 601-171 (200 MM) - 601-258 (250 MM)**
- 601-172 (300 MM) - 601-180 (340 MM)**
- 601-182 (400 MM)**

Double metal pegboard display arm.  
 Hole perforation: 25 to 30 mm.

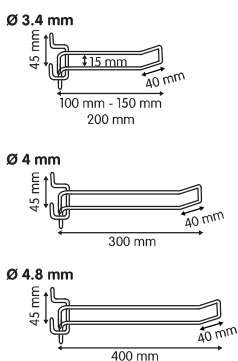

- ◎ **601-184 (100 MM) - 601-185 (150 MM)**
- 601-186 (200 MM) - 601-187 (300 MM)**
- 601-188 (400 MM)**

Double metal pegboard display arm.  
 Hole perforation: 45 mm.

**05**

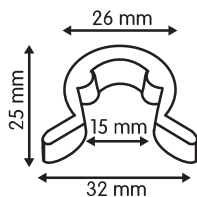

- ◎ **601-235**

White PVC stock limiter for double display arm.

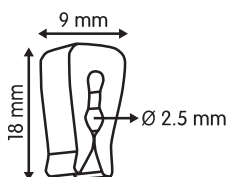

- ◎ **601-236**

White PVC stock limiter for single display arm.

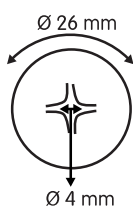

- ◎ **601-194**

Clear plastic round stock limiter for single display arm.



◎ **601-227**

Clear plastic swing tag for single display arm.

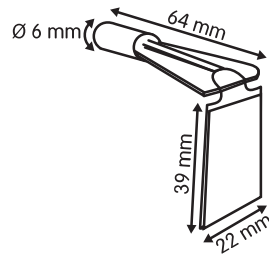

◎ **601-219**

Clear plastic tag pocket for wire basket.

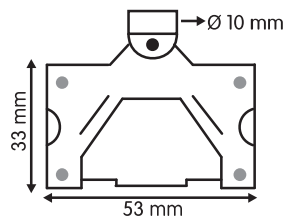

◎ **601-360**

**NEW**

Clear plastic tag pocket for double display arm.

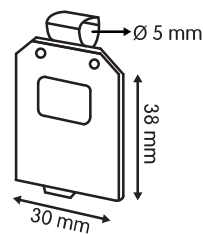

◎ **601-276**

Clear plastic tag pocket for double display arm.

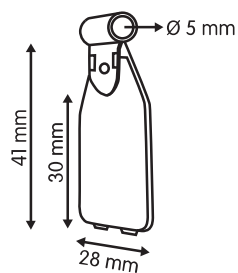

◎ **601-229**

White polyethylene tag pocket for double display arm.

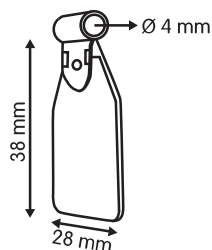

**05**

**DISPLAY ACCESSORIES**  
**DISPLAY ARMS AND ACCESSORIES**

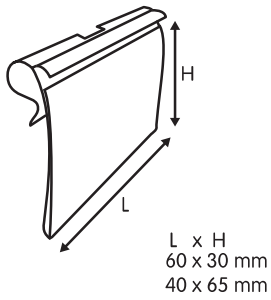

◎ **605-104**

Clear PVC tag pocket for double display arm.

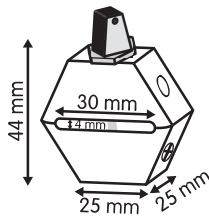

◎ **601-225**

Red or grey polypropylene anti theft lock for double metal display arm. Open and close with key. Capacity: maximum 4 mm.

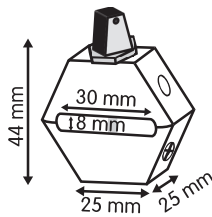

◎ **601-368** **NEW**

Black polypropylene safety anti theft lock for double metal display arm. Open and close with key. Capacity: 6 to 8 mm.

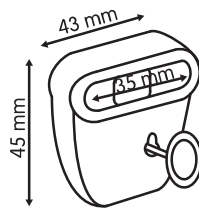

◎ **601-369** **NEW**

Red plastic safety anti theft lock for double metal display arm. Open and close with key.

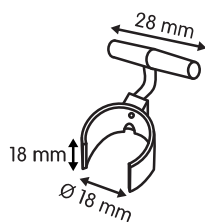

◎ **601-195**

White plastic tag holder for tubes.

© 601-800

Rotating product display, 4-sided counter stand. Delivered with 42 double display arms. Self assembly.

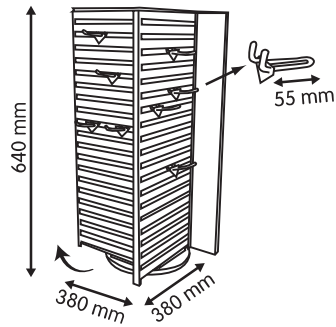

© 601-801

Rotating product display, 3-sided floor stand. Delivered with 100 double display arms. Self assembly.

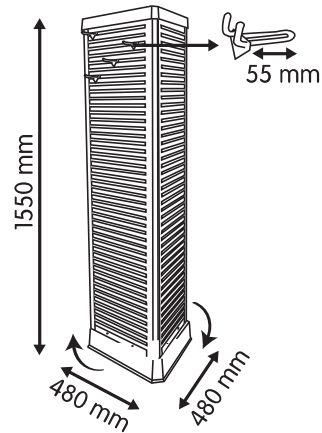

**DISPLAY ACCESSORIES**  
**HANG TABS**

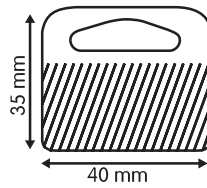

⊙ **L2 - 380μ**

Clear adhesive flexi PET hang tab.

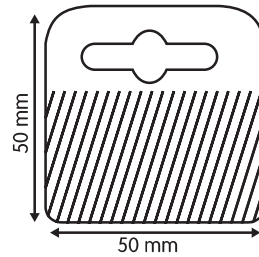

⊙ **L3105 - 500μ**

Clear adhesive flexi PET hang tab with euro slot.

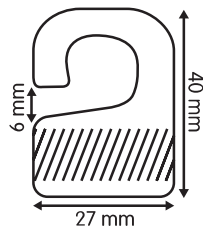
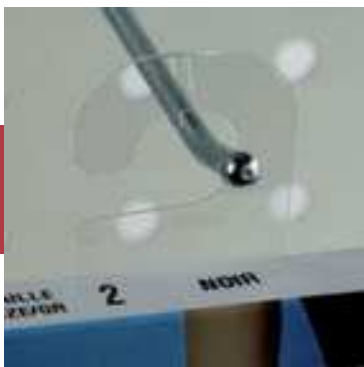

⊙ **L3 - 500μ**

Clear adhesive flexi PET hang tab.

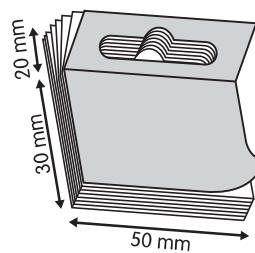

⊙ **P2000**

Clear adhesive flexi PET hang tab with euro slot. 1 pad = 10 hang tabs.

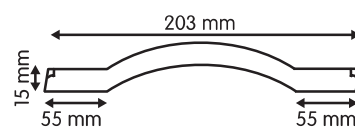

⊙ **300-903**

Clear PET hang strap with 2 adhesive ends. Ideal to hang round and uneven shaped products. 1 booklet = 10 hang straps.

**05**

© **604-049 - 604-038**

White polypropylene flag pole holder (90 or 60 degree) for use with flag pole (ref: 604-050), with adhesive and 4 perforations.

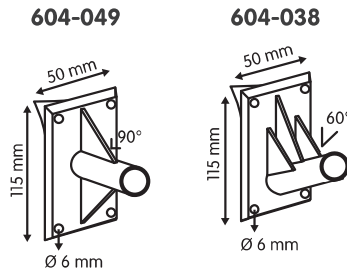

© **604-050**

White PVC flag pole with slit.

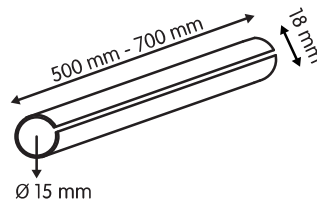

© **604-051**

White PVC round end cap for use with flag pole (ref: 604-050).

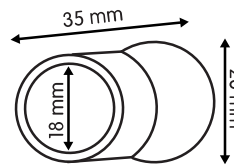

05

© **604-052**

White PVC flag stopper for flag pole (ref: 604-050). The guide fits over the flag pole to hold the flag in position.

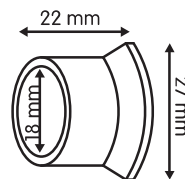

**DISPLAY ACCESSORIES**  
POLE ACCESSORIES

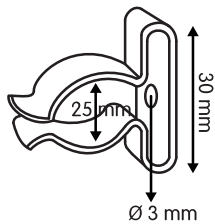

◎ **604-080** **NEW**

Metal clip with perforation for pole.

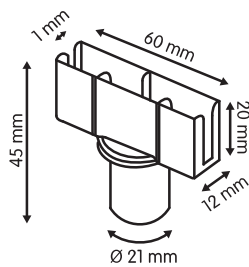

◎ **604-073**

White styrene top card holder for (cardboard) poles.



**604-074**

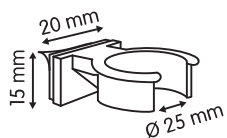

◎ **604-074 - 604-075**

White PVC clip with adhesive for (cardboard) poles.

**604-075**

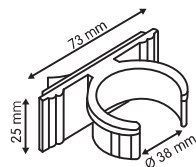

◎ **604-076**

White styrene connector for (cardboard) poles.

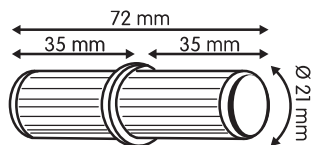

◎ **604-077**

White styrene foot with adhesive for (cardboard) poles.

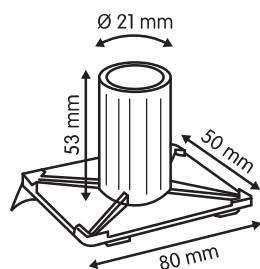



◎ **602-109**

White or black plastic turntable (flat model).

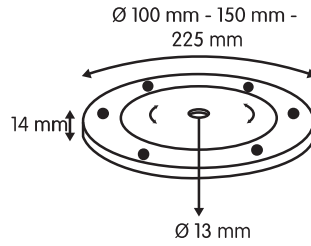

◎ **602-081**

Rotating display for mobile phone. Battery not included.

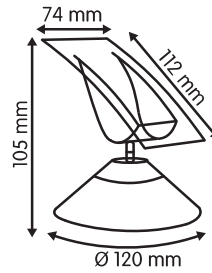

◎ **602-095**

Rotating display with large gripper. Battery not included.

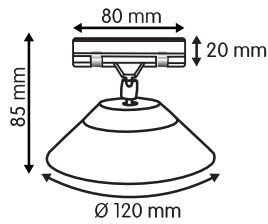

◎ **602-096**

Rotating display unit with flat, round base plate. Operates from solar power.

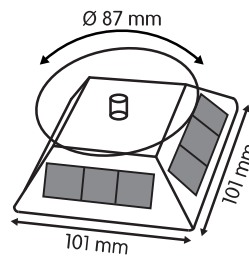

◎ **611-083**

Transparent blue plastic solar motor. Operates from solar power.

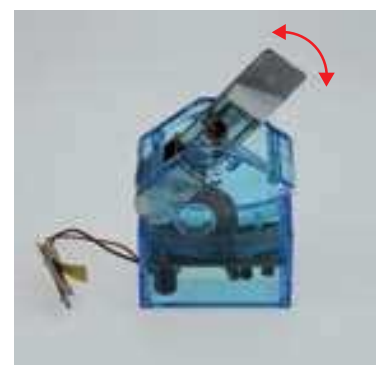
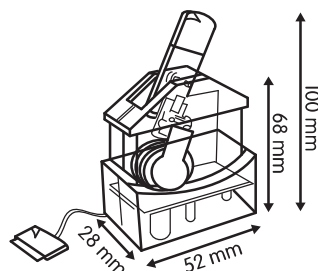

05

**DISPLAY ACCESSORIES**  
**DISPLAY CONSTRUCTION**

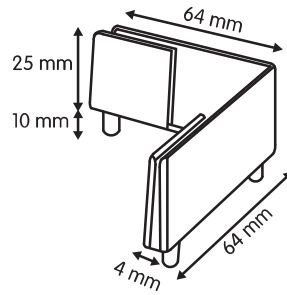

◎ **609-004**

White styrene display foot.  
 90° corner with 10 mm ground clearance.

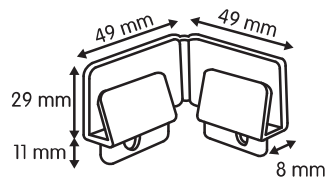

◎ **609-003**

Clear polypropylene display foot.  
 Provides 11 mm ground clearance and  
 can be formed to any angle.

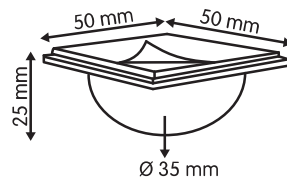

◎ **609-001**

Clear polypropylene round display foot  
 with adhesive.  
 Provides 25 mm ground clearance.

05

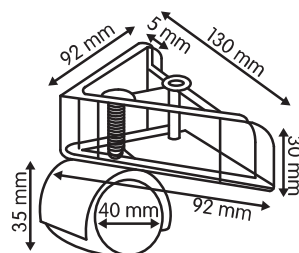

◎ **609-002**

Strong castor which provides up to 20 kg  
 per foot weight loading.  
 1 set = 4 pieces + 1 key  
 (optional: wheel with break mechanism).

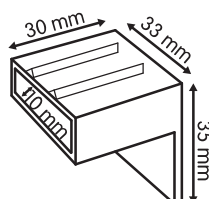

◎ **609-015**

Black ABS end cap for use with support  
 rail (ref: 609-014). For quick and secure  
 corrugated shelf construction

© 609-014 **NEW**

Black ABS support rail, for use with end cap (ref: 609-015). For quick and secure corrugated shelf construction.

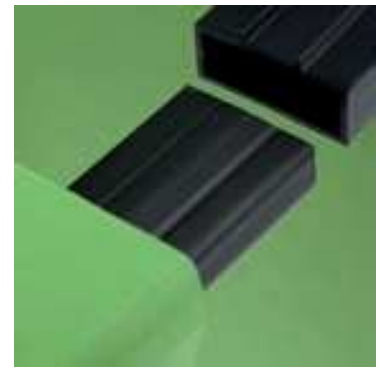
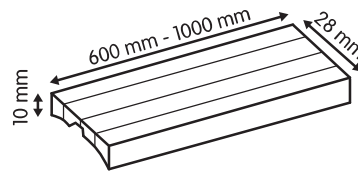

© 609-005 **NEW**

White polypropylene two piece shelf support for bonding into corrugated cardboard free standing display stands.

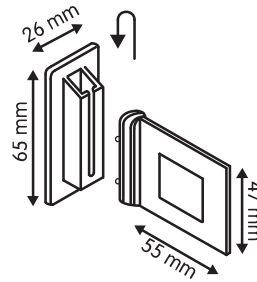

© 609-010 **NEW**

White ABS two piece connector for quick and secure corrugated shelf construction.

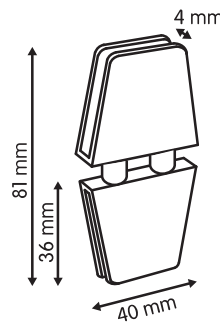

© 609-011 **NEW**

White polypropylene connector (L shape) for quick and secure corrugated shelf construction.

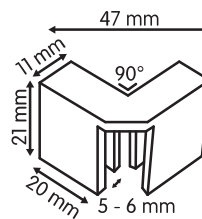

© 609-013 **NEW**

White polypropylene connector (T shape) for quick and secure corrugated shelf construction.

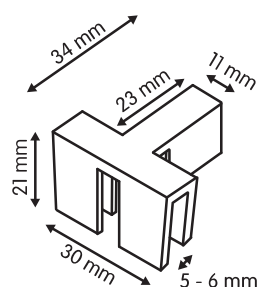

05

**DISPLAY ACCESSORIES**  
**DISPLAY CONSTRUCTION**

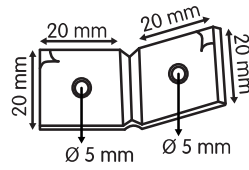

◎ **609-017**

**NEW**

Clear ABS flexible hinge with adhesive.

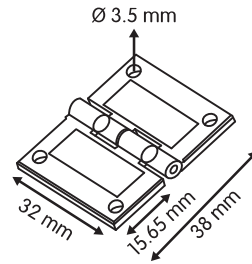

◎ **609-006**

**NEW**

Clear polycarbonate flexible hinge.

**05**

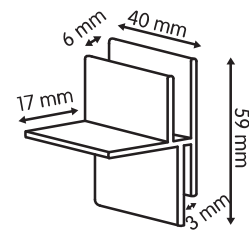
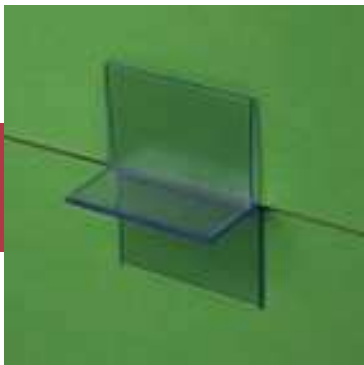

◎ **609-007**

**NEW**

Clear PVC clip for quick and secure corrugated shelf construction by slotting into die cut holes.

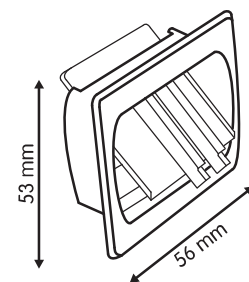

◎ **609-008**

**NEW**

White polypropylene protection clip for cardboard box with lid.

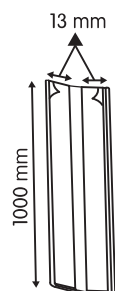

◎ **609-016**

Clear PVC hinged profile with 2 strips of foam adhesive.

◎ **611-246 (6 MM) - 611-244 (12 MM)**  
**611-245 (22 MM)**

Clear plastic viking screw with permanent one way feature.

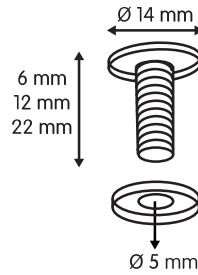

◎ **611-086 (13 MM) - 611-247 (25 MM)**

Clear plastic viking screw with permanent one way feature.

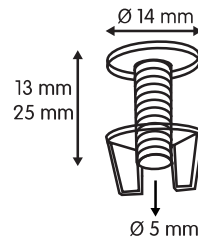

◎ **611-195 (3 MM) - 611-087 (6 MM)**  
**611-196 (9 MM) - 611-197 (12 MM)**

Clear polypropylene thumb snap with permanent one way feature.

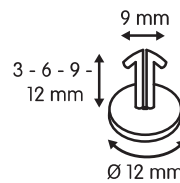

◎ **611-088 (2.5 MM) - 611-095 (5 MM)**  
**611-096 (7.5 MM)**

White or black polypropylene rivet with permanent one way feature.

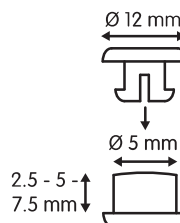

◎ **611-097 (2.5 MM) - 611-248 (3 MM)**  
**611-089 (5 MM)**

Clear plastic rivet with permanent one way feature. A hole runs through both parts for use with a pearl chain or a cord.

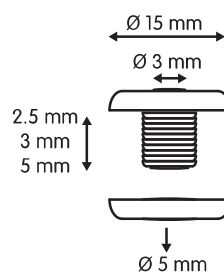

**PRINTING ACCESSORIES**

**RIVETS**

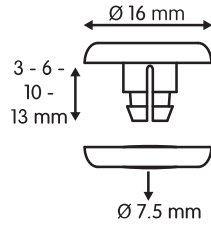

- ◎ **611-150 (3 MM) - 611-151 (6 MM)**  
**611-141 (10 MM) - 611-152 (13 MM)**

Clear polypropylene rivet with permanent one way feature.

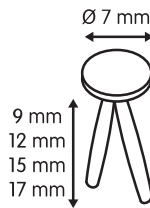
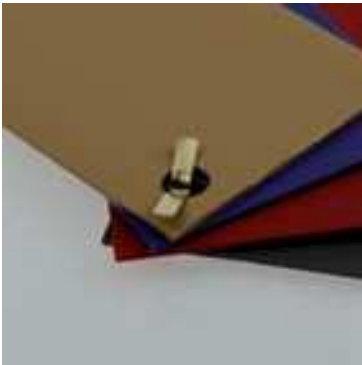

- ◎ **611-091 (9 MM) - 611-237 (12 MM)**  
**611-238 (15 MM) - 611-239 (17 MM)**

Brass finish split pin.

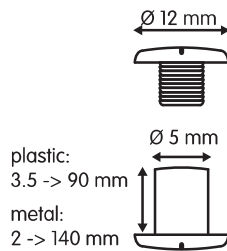

- ◎ **611-297 (3.5 MM) - 611-092 (5 MM)**  
**611-098 (8 MM) - 611-099 (10 MM)**  
**611-100 (15 MM) - 611-101 (20 MM)**  
**611-102 (25 MM) - 611-103 (30 MM)**  
**611-104 (35 MM) - 611-105 (40 MM)**  
**611-106 (45 MM) - 611-107 (50 MM)**  
**611-298 (60 MM) - 611-299 (80 MM)**

Nylon or metal re-usable screwlock. Standard colours: white (nylon) - black (nylon) - brass finish (metal) - chrome finish (metal).

**06**

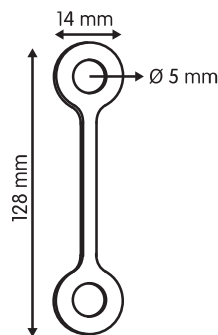

- ◎ **611-240**

White nylon screwlock hanger for use with screwlock. Minimum capacity of the screwlock: 8 mm (when using the hanger, the capacity of the screwlock is reduced with 4 mm).

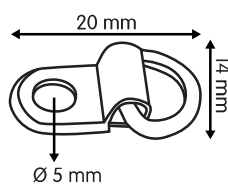

- ◎ **611-240**

Chrome finish metal hanger for use with metal screwlock.



- ◎ **611-157 (3.5 MM) - 611-158 (5 MM)**  
**611-159 (10 MM) - 611-160 (15 MM)**  
**611-161 (20 MM)**

White or black nylon re-usable screwlock.  
A hole runs through both parts for use with a pearl chain or a cord.

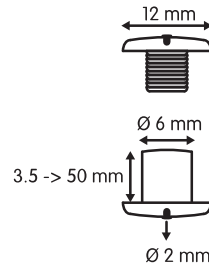

- ◎ **611-093 - 611-111**

Plastic mini rivet with permanent one way feature. Standard colours: white - black - transparent.

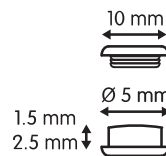

- ◎ **611-236**

Clear polypropylene thumbsnap.  
Just press the button to open the thumbs.  
Ideal for assembly in hard-to-reach areas.

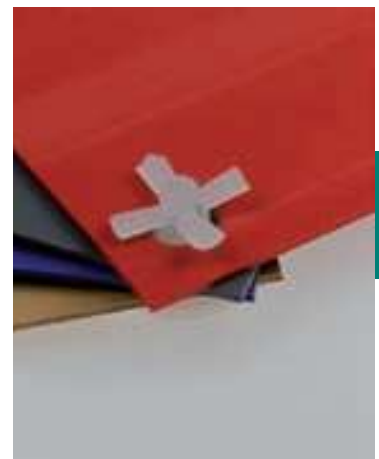
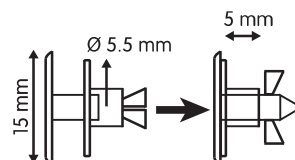

- ◎ **611-243**

Clear polypropylene rivet with permanent one way feature. Large-diameter pin for better grip.

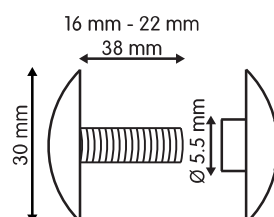



**PRINTING ACCESSORIES**  
HOOKS AND LOOPS

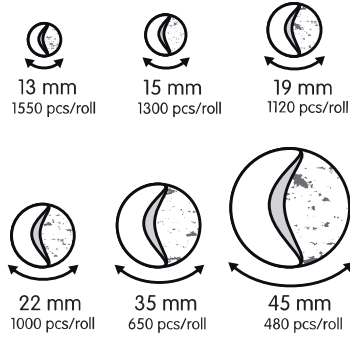
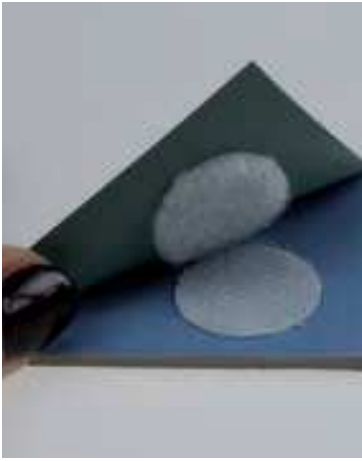

- ◎ **611-280 (13 MM) - 611-281 (15 MM)**  
**611-282 (19 MM) - 611-283 (22 MM)**  
**611-284 (35 MM) - 611-285 (45 MM)**

White or black adhesive velcro dots.  
Hook and loop on separate reel.

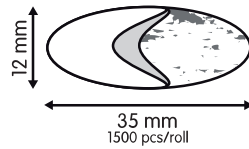

- ◎ **611-286**

White or black adhesive velcro dots, with  
easy-peel. Hook and loop combined on  
1 reel => less actions required!

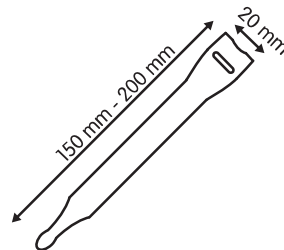

- ◎ **611-287 (150 MM) - 611-288 (200 MM)**

Velcro 'one-wrap' self gripping fastener.  
Hook and loop combined on one  
fastener.

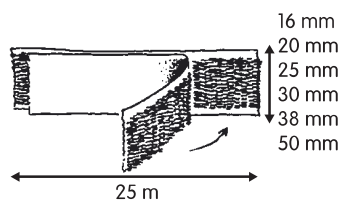

- ◎ **611-289 (16 MM) - 611-290 (20 MM)**  
**611-291 (25 MM) - 611-292 (30 MM)**  
**611-293 (38 MM) - 611-295 (50 MM)**

White or black adhesive velcro.  
Hook and loop on separate reel.

◎ **611-252 - 611-035 - 611-253**

White foam pads with double sided permanent adhesive.

**611-252**  
1000 pcs/reel

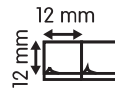

**611-035**  
1000 pcs/reel

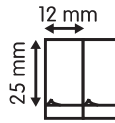

**611-253**  
500 pcs/reel

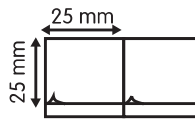

◎ **611-254**

White round foam dots with double sided permanent adhesive.

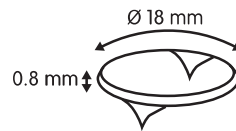

5000 pcs/reel



◎ **611-256**

Clear round dots with thin adhesive tape. Peelable tape at one side.

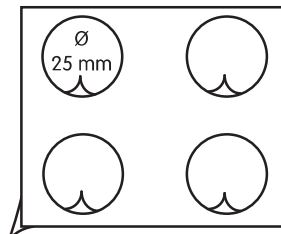

5000 pcs/reel



◎ **611-258**

Clear round dots with thin adhesive tape. Peelable tape at one side.

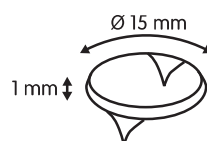

500 pcs/reel



**PRINTING ACCESSORIES**  
**TAPE AND MAGNETIC TAPE**

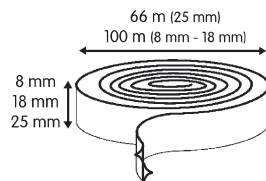

◎ **611-257**

White foam tape with double sided permanent adhesive.

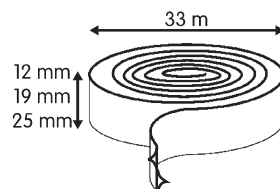

◎ **611-259**

Clear acrylic tape with double sided peelable adhesive.  
Adheres securely on to polypropylene.

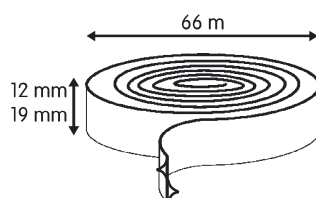

◎ **611-260**

Black acrylic foam tape with double sided peelable adhesive.  
Adheres to polypropylene.

06

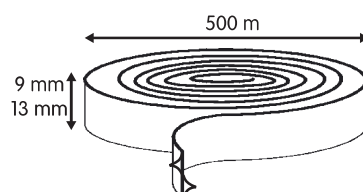

◎ **611-261**

Clear thin tape with double sided permanent adhesive.

◎ **611-263**

Clear round dots with single sided permanent thin adhesive.

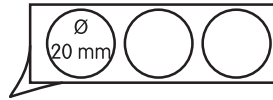

2000 pcs/reel



◎ **611-262**

Clear round dots with single sided peelable thin adhesive tape.

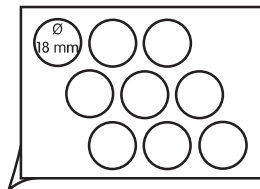

2000 pcs/reel



◎ **611-264**

Clear round dots (with perforation in the middle) with single sided permanent thin adhesive.

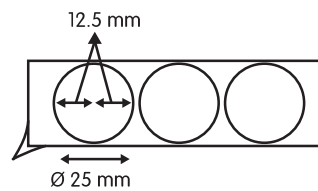

2000 pcs/reel



◎ **611-255**

**NEW**

Clear acrylic dots with double sided adhesive tape.  
No adhesive residue is left when removed.

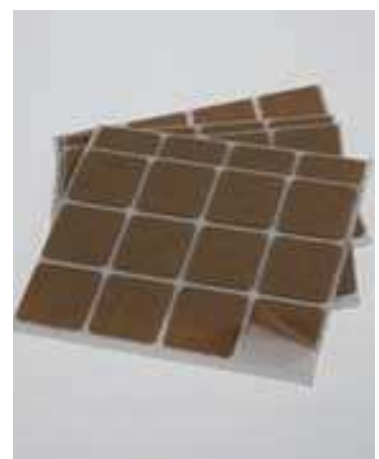
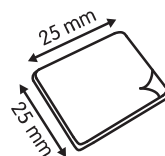

**PRINTING ACCESSORIES**  
TAPE AND MAGNETIC TAPE

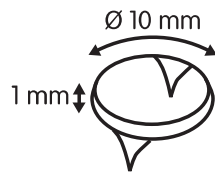

5000 pcs/dispenser box

◎ **611-250**

Removable glue dots.

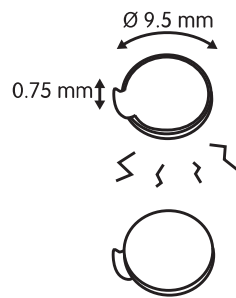

◎ **611-179**

Self adhesive round magnetic discs (matching poles).

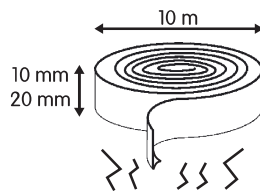

◎ **611-267 (10 MM) - 611-268 (20 MM)**

Magnetic tape on reel, with adhesive.

■ ↓ 1 mm - 1.5 mm

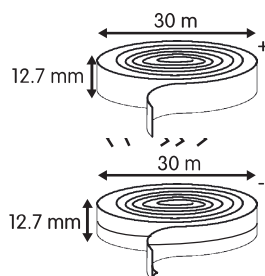

◎ **611-156**

Magnetic tape with matching poles on reel, with adhesive.

■ ↓ 1.5 mm

◎ **611-112**

White PVC covered metal ring binder with adhesive.

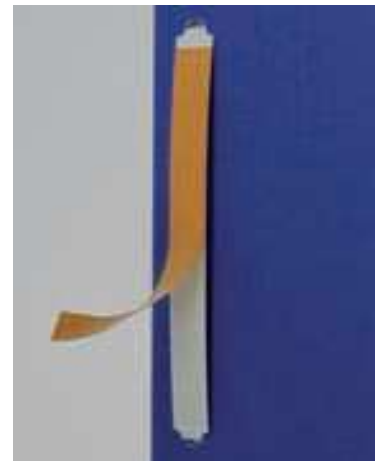
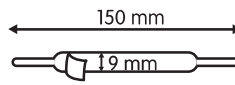

◎ **611-113**

Metal ring binder.  
Standard colours: white (= white PVC covered metal) - brass metal.

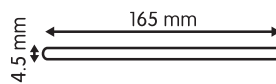

◎ **611-114**

White PVC or brass metal document clip for use with ring binder (ref: 611-112 - 611-113).

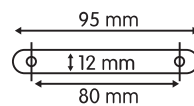

◎ **611-249**

Clear polypropylene adhesive filestrip with perforations.

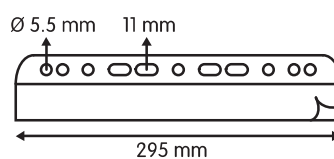

**PRINTING ACCESSORIES**  
CD ACCESSORIES

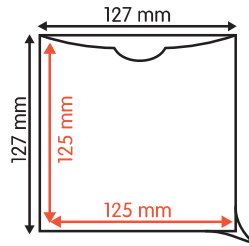

◎ **611-137**

Clear PVC adhesive CD pocket with semicircular finger cut.

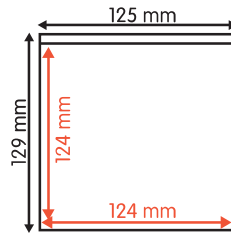

◎ **611-138**

Clear PVC non-adhesive CD pocket without semicircular finger cut.

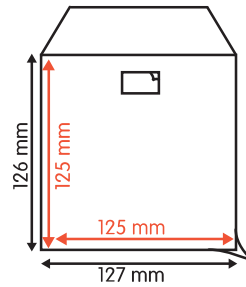

◎ **611-270**

Clear polypropylene adhesive CD pocket with adhesive closure.

06

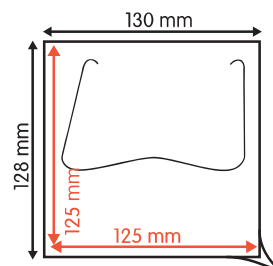

◎ **611-139**

Clear PVC adhesive CD pocket with flap.

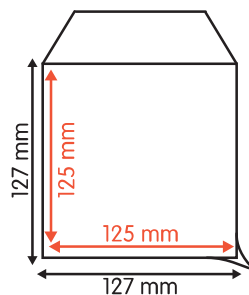

◎ **611-140**

Clear PVC non-adhesive CD pocket with non-adhesive closure.



◎ **611-271**

Clear polypropylene adhesive USB pocket with adhesive closure.

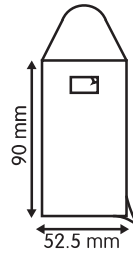

◎ **611-071**

White or black adhesive foam CD dots.

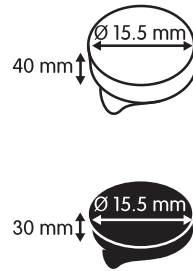

◎ **611-148**

Plastic adhesive round CD spider. Standard colours: white - black - transparent.

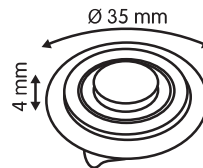

◎ **611-072**

Clear polystyrene adhesive square CD spider.

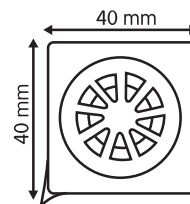

◎ **611-149 - 611-296**

Plastic non-adhesive CD tray or DVD tray (to fix with hot-melt). Standard colours: white - black - transparent (CD tray), transparent (DVD tray).

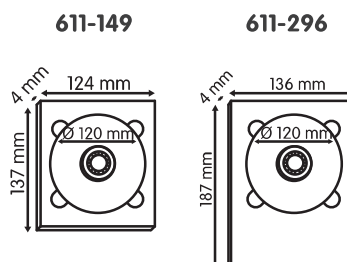

06

**PRINTING ACCESSORIES**

**CHAINS**

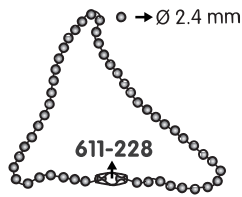

◎ **611-227**

Metal pearl chain.  
Available in different standard lengths,  
can also be supplied on reels or cut to a  
length to suit you.

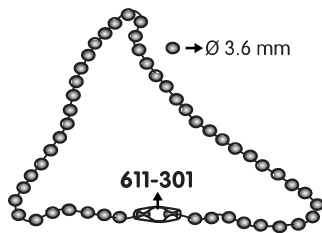

◎ **611-300**

Metal pearl chain.  
Can be supplied on reels or cut to a  
length to suit you.



**611-228**

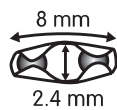

**611-301**

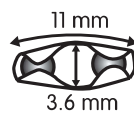

◎ **611-228 - 611-301**

Metal connector for use with pearl chain  
(ref: 611-227 or 611-300).

**06**



**611-229**

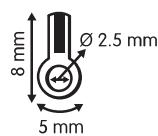

**611-230**

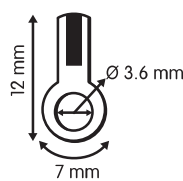

◎ **611-229 - 611-230**

Metal fastener for use with pearl chain  
(ref: 611-227 or 611-300).

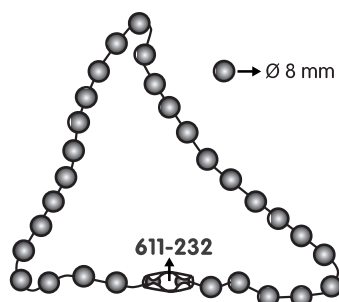

◎ **611-231**

Metal pearl chain.  
Can be supplied on reels or cut to a  
length to suit you.

◎ **611-232**

Metal connector for use with pearl chain (ref: 611-231).

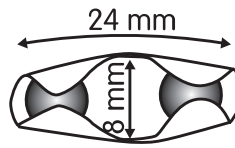

◎ **611-011**

Metal split-ring.

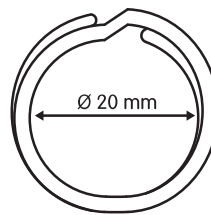

◎ **611-225**

Metal triangle hook.

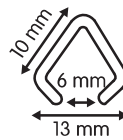

◎ **611-226**

Metal chain.  
Can be supplied on reels or cut to a length to suit you.

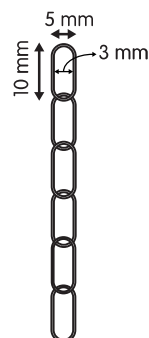

Ø 1 mm



**PRINTING ACCESSORIES**  
RINGS AND HOOKS



**601-170**  
(2 mm)

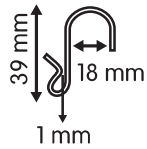

**601-232**  
(2.5 mm)

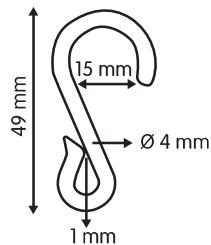
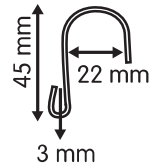

Ø 4 mm



**601-166**  
(2.1 mm)



**601-175**  
(2.5 mm)



**601-176**  
(2 mm)

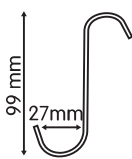

**601-177**  
(3 mm)

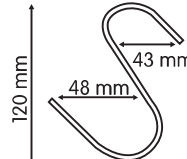

◎ **601-166 - 601-175 - 601-176 - 601-177**

Metal 'S'-hook.

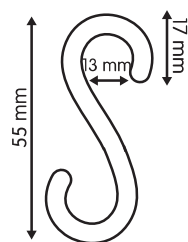

Ø 5 mm

◎ **601-174**

White polypropylene 'S'-hook.

© 601-173 - 601-178 - 601-179

Metal 'C'-hook.

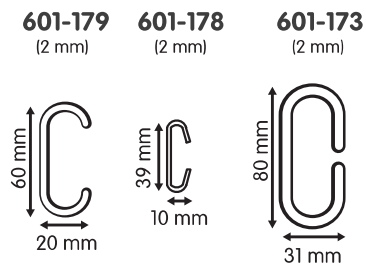

© 611-001 - 611-002

White plastic oval popping.

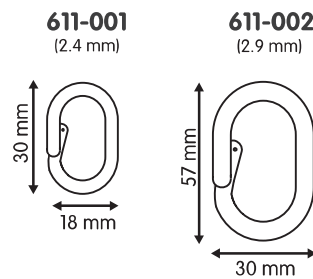

© 611-215

Clear polycarbonate oval popping.

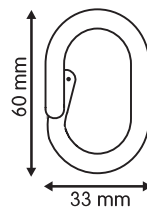

Ø 4.2 mm



© 611-003 - 611-004

White polypropylene round popping.

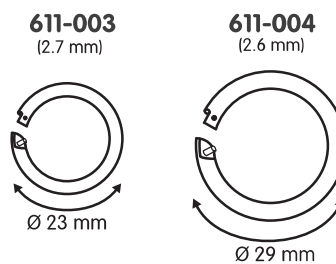

**PRINTING ACCESSORIES**  
RINGS AND HOOKS

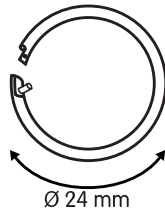

Ø 2.5 mm

◎ **611-216**

Clear plastic round popping.

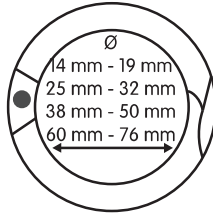

<b>611-005:</b> 2 mm	<b>611-009:</b> 3.3 mm
<b>611-006:</b> 2.3 mm	<b>611-010:</b> 3.4 mm
<b>611-007:</b> 2.7 mm	<b>611-142:</b> 3.5 mm
<b>611-008:</b> 3.2 mm	<b>611-143:</b> 4.5 mm

◎ **611-005 (14 MM) - 611-006 (19 MM)**  
**611-007 (25 MM) - 611-008 (32 MM)**  
**611-009 (38 MM) - 611-010 (50 MM)**  
**611-142 (60 MM) - 611-143 (76 MM)**

Metal round locking ring.

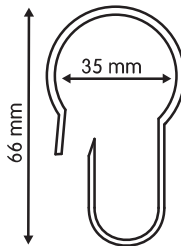

Ø 2 mm

◎ **611-163**

Metal clip for pole.

06

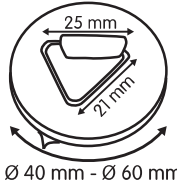

◎ **604-008 (25 MM)**  
**604-053 (40 MM)**  
**604-054 (60 MM)**

**NEW**

White ABS adhesive photo hook with metal triangle.

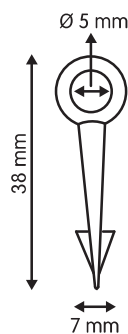

◎ **609-009**

**NEW**

White polypropylene rivet for cardboard display boards.

- ⊙ **20 MM: 608-011 (A3) - 608-013 (A4)**  
608-012 (A5) - 608-127 (A6)
- 25 MM: 608-035 (A1) - 608-036 (A2)**  
608-037 (A3) - 608-034 (50 X 70 CM)  
608-017 (70 X 100 CM)
- 32 MM: 608-058 (A0)**

Aluminium snap frame with mitred corners. Supplied with transparent anti-reflective PET-cover. Screws and plugs included.

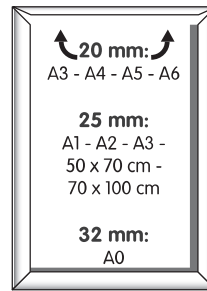

⊙ **608-025**

Metal stand for angled presentation of snap frame (ref: 608-013).

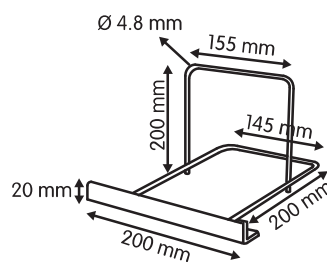

- ⊙ **14 MM: 608-117 (A5) - 608-118 (A6)**
- 25 MM: 608-123 (A4) - 608-122 (A3)**  
608-121 (A2) - 608-120 (A1)  
608-119 (50 X 70 CM)
- 32 MM: 608-125 (A1) - 608-124 (50 X 70 CM)**



Aluminium snap frame with round corners, backing in grey plastic. Supplied with transparent anti-reflective PET-cover. Optional: counter support.

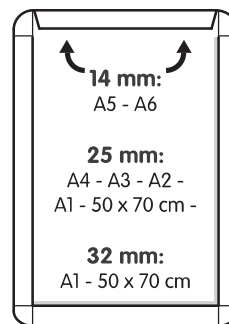

- ⊙ **608-097 (A0) - 608-096 (A1) - 608-095 (A2)**  
608-024 (A3) - 608-098 (50 X 70 CM)  
608-099 (70 X 100 CM)

Aluminium snap frame with mitred corners, lockable with special key (included). Supplied with transparent anti-reflective PET-cover. Screws and plugs included.

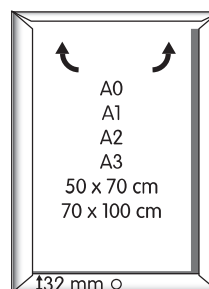



**FRAMES**  
SNAP FRAMES

**NEW**

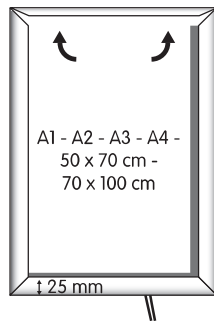

- ⊙ **608-130 (A1) - 608-131 (A2)**
- 608-155 (A3) - 608-132 (A4)**
- 608-128 (50 X 70 CM)**
- 608-129 (70 X 100 CM)**

Aluminium snap frame with LED illumination, mitred corners. The specially treated acrylic in the middle provides a homogenous lighting. Supplied with transparent anti-reflective PET-cover. Screws and plugs included.

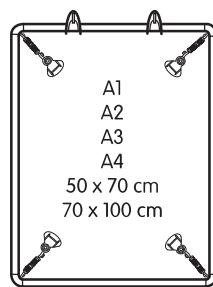

- ⊙ **608-112 (A1) - 608-111 (A1) - 608-027 (A3)**
- 608-026 (A4) - 608-113 (50 X 70 CM)**
- 608-114 (70 X 100 CM)**

Silver anodised stretch frame with black plastic corners. Supplied with 4 plastic clips and 2 plastic hangers. Self assembly.

Suggested poster material: paper (heavier material such as vinyl or textile may damage the springs on the corner).

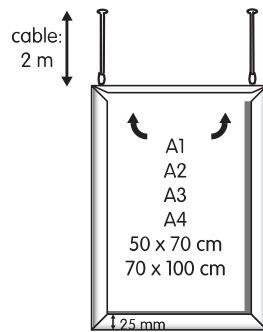

- ⊙ **608-137 (A1) - 608-138 (A2)**
- 608-139 (A3) - 608-140 (A4)**
- 608-135 (50 X 70 CM)**
- 608-136 (70 X 100 CM)**

Aluminium snap frame (double sided) with 2 aluminium wire cables, mitred corners. Cables can be mounted in portrait or landscape position. Supplied with transparent anti-reflective PET-cover.

**07**

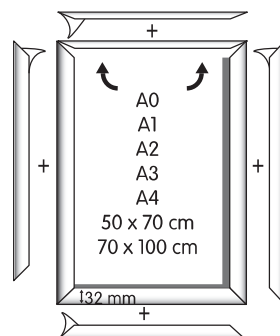

- ⊙ **608-143 (A0) - 608-144 (A1)**
- 608-145 (A2) - 608-146 (A3)**
- 608-147 (A4) - 608-141 (50 X 70 CM)**
- 608-142 (70 X 100 CM)**

Aluminium window snap frame (double sided) with adhesive, mitred corners. The system includes 4 decorative back profiles to hide the tape which holds the snap frame to the window. Supplied with 2 transparent anti-reflective PET-covers.

© 608-133 (A3) - 608-134 (A4)

NEW

Aluminium counter stand 'slide-in' frame (double sided) with adhesive feet. Frame is suitable for outdoor use when equipped with the sealing rubber on the open edge. Supplied with 2 transparent anti-reflective PET-covers.

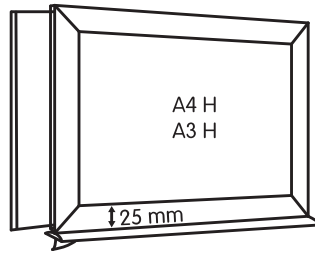

© 608-151 (A0) - 608-032 (A1) - 608-033 (A2)  
608-028 (A3) - 608-149 (50 X 70 CM)  
608-050 (70 X 100 CM)

Aluminium lockable memo board, mitred corners. Key, screws and plugs included. 100% WATERPROOF.

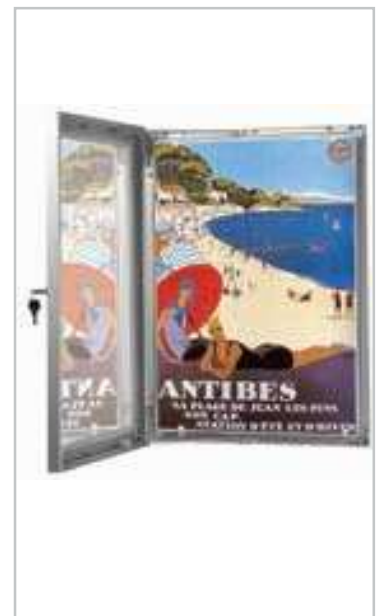
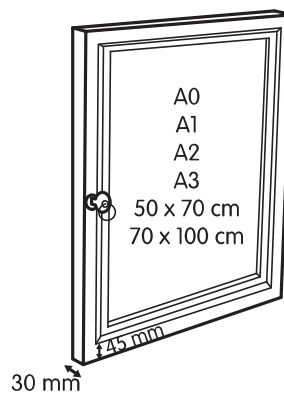

© 608-029 (4 X A4) - 608-153 (6 X A4)  
608-154 (9 X A4) - 608-152 (12 X A4)

Aluminium lockable magnetic memo board, mitred corners. Can be mounted in portrait or landscape position. Key, set of magnets, screws and plugs included. 100% WATERPROOF.

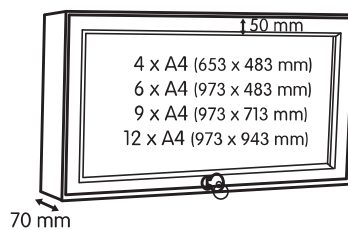

**FRAMES**

**ALUMINIUM SHOWCARD STANDS**

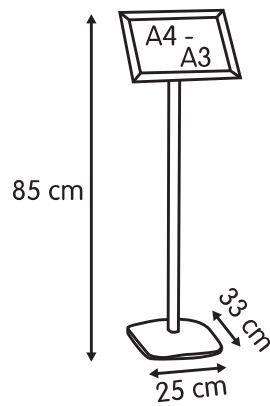

◎ **606-460 (A4) - 606-461 (A3)**

Aluminium showcard stand with snap frame, mitred corners. The snap frame can be used in portrait or landscape position. Supplied with transparent anti-reflective PET-cover.

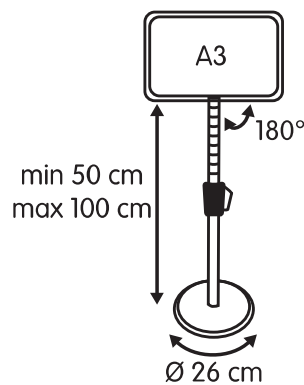

◎ **606-464**

Aluminium showcard stand with snap frame (round corners), plastic base and extendable tube. The snap frame can be used in portrait or landscape position. Supplied with transparent anti-reflective PVC-cover.

**07**

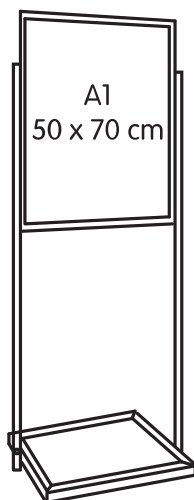

◎ **606-200 (A1)**  
**606-199 (50 X 70 CM)**

**NEW**

Black aluminium floor stand, double sided. Supplied with 2 transparent anti-reflective PET-covers and 1 black PVC-cover. The black PVC in the middle of 2 posters prevent light transmission. Self assembly.

© 607-064 (A3) - 607-018 (A4)  
607-065 (A5)

Plastic showcard stand.  
1 set comprises a **plastic base plate**, extendible chromed tube, plastic T-piece and plastic frame.

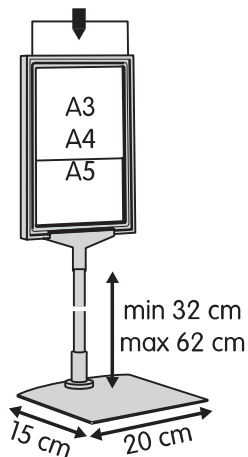

© 607-066 (A2) - 607-067 (A3)  
607-068 (A4) - 607-069 (A5)

Plastic showcard stand.  
1 set comprises a **metal base plate covered with plastic**, extendible chromed tube, plastic T-piece and plastic frame.

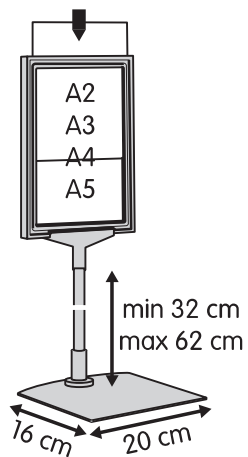

© 607-070 (A3) - 607-075 (A4)

Plastic showcard stand.  
1 set comprises a **metal base plate**, extendible chromed tube, plastic T-piece, plastic frame and anti-reflective cover.

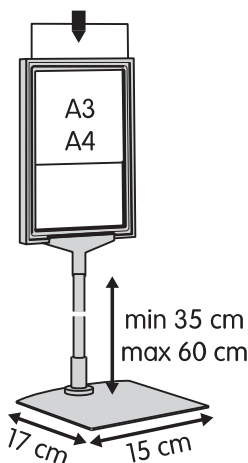

07

**FRAMES**

**PLASTIC SHOWCARD STANDS AND ACCESSORIES**

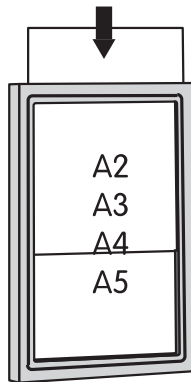

- ◎ 607-071 (A2)- 607-072 (A3)
- 607-073 (A4) - 607-074 (A5)

Plastic frame.

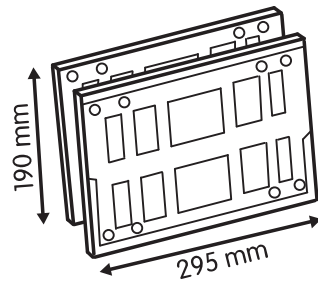

- ◎ 607-081 **NEW**

Red polypropylene frame (double sided) for displaying messages on a trolley. Screws included.

**07**

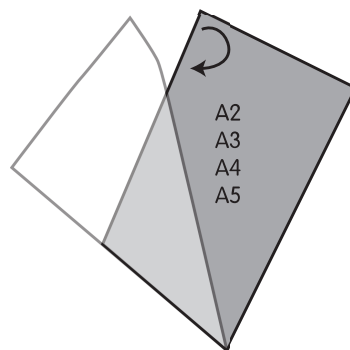

- ◎ 607-023 (A2) - 607-034 (A3)
- 607-035 (A4) - 607-036 (A5)

Transparent anti-reflective PVC-cover for use with showcard stand.

◎ **607-079**

Clear plastic connector.

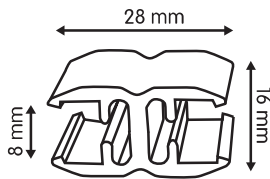

◎ **607-080**

Clear plastic open top hanger.

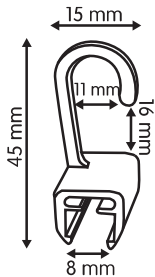

◎ **607-076**

Clear plastic open left side hanger.

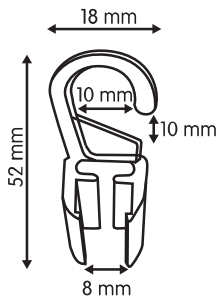

◎ **607-077**

Clear plastic open right side hanger.

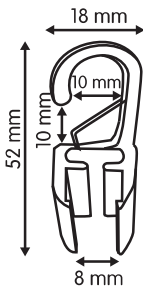

◎ **607-078**

Clear plastic closed top hanger.

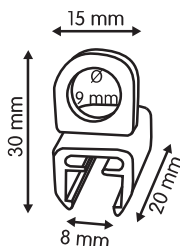

07



**FRAMES**  
PAVEMENT SIGNS

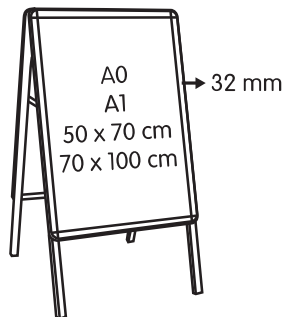

- ◎ **607-053 (A0)**
- 607-054 (A1)**
- 607-052 (50 X 70 CM)**
- 607-051 (70 X 100 CM)**

Aluminium A-pavement sign (double sided) with snap frame, mitred corners. Supplied with transparent anti-reflective PET-cover. Suitable for outdoor use  
NON-WATERPROOF.

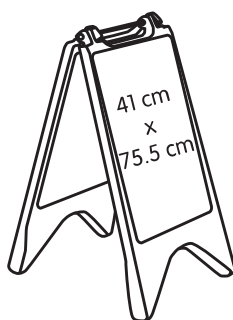

- ◎ **607-090**

Grey (RAL 9006) plastic A-pavement sign (double sided), mitred corners. Can be filled with water or sand.  
100% WATERPROOF.

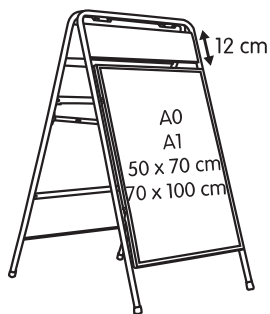

- ◎ **607-046 (A0)**
- 607-047 (A1)**
- 607-062 (50 X 70 CM)**
- 607-044 (70 X 100 CM)**

Aluminium magnetic A-pavement sign (double sided), round corners. Supplied with magnetic transparent cover. 100% WATERPROOF.

07

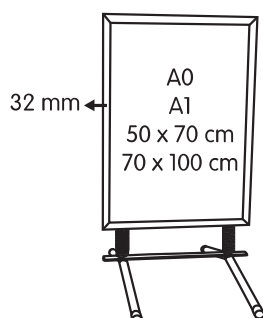

- ◎ **607-088 (A0)**
- 607-089 (A1)**
- 607-086 (50 X 70 CM)**
- 607-024 (70 X 100 CM)**

Aluminium pavement sign (double sided) with snap frame, mitred corners. Spring legs hold the frame stable. Supplied with transparent anti-reflective PET-cover. Self assembly.  
100% WATERPROOF.



- © 607-050 (A0)
- 607-049 (A1)
- 607-091 (50 X 70 CM)
- 607-048 (70 X 100 CM)

Aluminium pavement sign (double sided) with snap frame, mitred corners. Spring legs hold the frame stable. Base can be filled with water or sand. Castors enable the unit to be easily removed. Supplied with transparent anti-reflective PET-cover. Self assembly. 100% WATERPROOF.

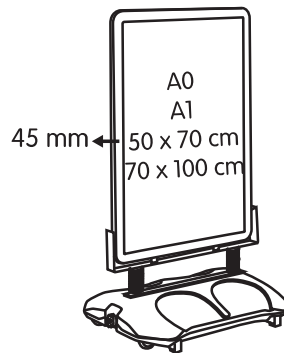

- © 607-085 **NEW**

Aluminium pavement sign with 4 in-built wheels, aluminium frame, magnetic edged poster wallet and plastic round base. To be filled with water. Supplied with magnetic transparent anti-reflective PET-cover. 100% WATERPROOF.

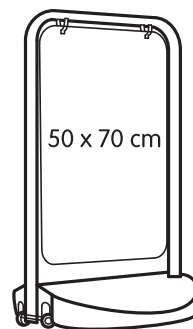

- © 607-084 **NEW**

Plastic 'A' chalk board (double sided). Easy to move and store.

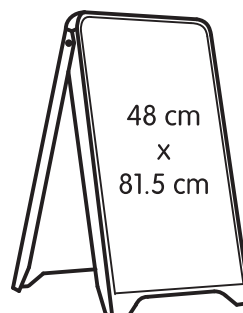

**FRAMES**  
**BANNER DISPLAYS**

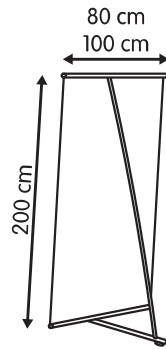

◎ **608-005 (80 CM) - 608-030 (100 CM)**

Aluminium banner display with poster clamp, single sided.  
Optional: carrier bag.

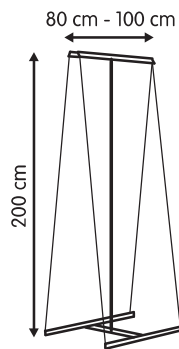

**NEW** ◎ **608-102 (80 CM) - 608-101 (100 CM)**

Aluminium banner display with poster clamp, double sided.

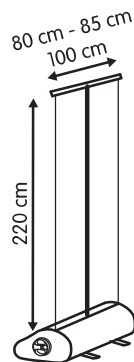

◎ **608-104 (80 CM) - 608-105 (85 CM)**  
**608-103 (100 CM)**

Aluminium roll-up banner display with telescopic pipe and poster clamp, single sided. Carrier bag included.

07

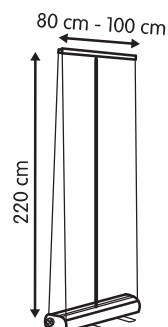

**NEW** ◎ **608-107 (80 CM) - 608-106 (100 CM)**

Aluminium roll-up banner display with telescopic pipe and poster clamp, double sided. Carrier bag included.

© 608-108

Aluminium roll-up banner display with poster clamp and adhesive profile on the bottom, single sided.  
Optional: carrier bag.

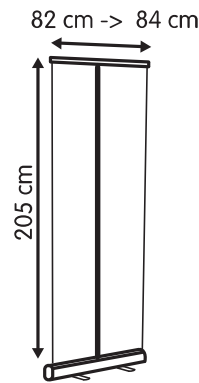

© 608-006

Flexible table top 'X' banner frame.

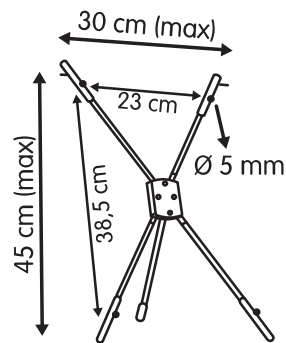

© 608-116

**NEW**

Steel poster trap.  
The 2 parts are screwed together trapping the poster to form a stable stand.  
Only suitable for indoor use.

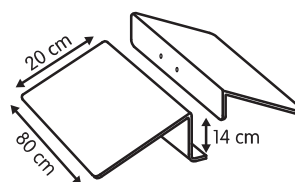

## FRAMES

### SHOP-WINDOW PRESENTATION

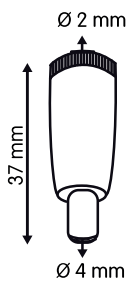

#### ◎ 604-066

Metal ceiling fixing (with 1 screw).

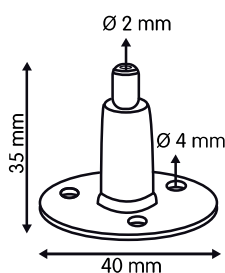

#### ◎ 604-067

Metal floor fixing (with 3 screws).

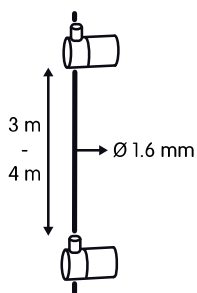

#### ◎ 604-068 (4 M) - 604-069 (3 M)

Steel cable.

07



© 604-070

Metal single poster clamp.

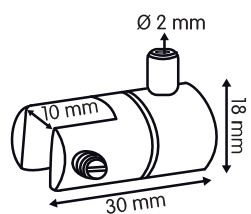

© 604-071

Metal double poster clamp.

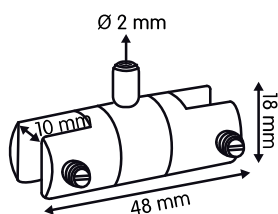

© 604-072

Clear PET poster pocket.

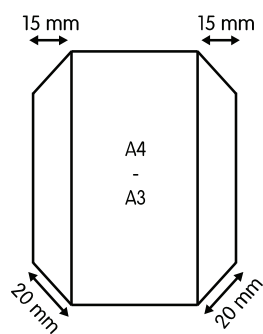

07



**MISCELLANEOUS  
SECURITY SYSTEMS**

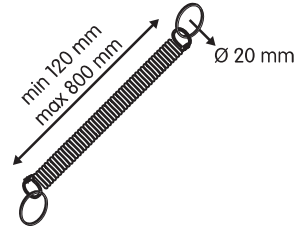

◎ **602-066**

Grey plastic extending safety coil with metal split-ring on either end.

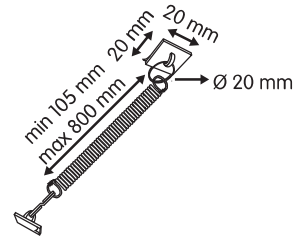

◎ **602-092**

Grey plastic extending safety coil with metal split-ring and adhesive disc on either end.

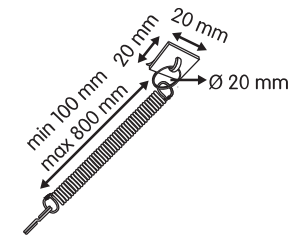

◎ **602-067 (GREY) - 602-084 (WHITE)**

Grey or white plastic extending safety coil with metal split-ring on either end and adhesive disc on one end.

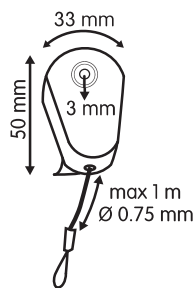

◎ **602-083**

Black plastic adhesive pull-box (anti theft) with fixing eye on the end of the cable.

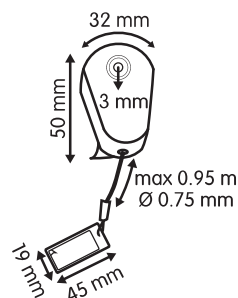

◎ **602-064**

Black plastic adhesive pull-box (anti theft) with adhesive disc on the end of the cable.

THE FOLLOWING HANDLES (TO 609-112) ARE AVAILABLE IN FOLLOWING COLOURS:

natural, white, black, green, blue, red, orange, brown and yellow.

◎ **609-100**

Polyethylene (soft) handle.

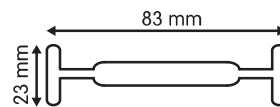

◎ **609-101**

Polyethylene (soft) handle.

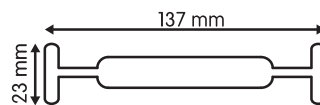

◎ **609-102**

Polyethylene (soft) handle.

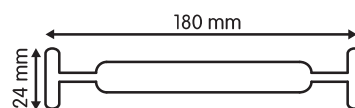

◎ **609-103**

Polyethylene (soft) handle.

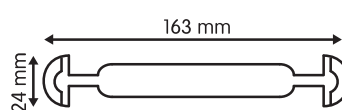



MISCELLANEOUS  
HANDLES

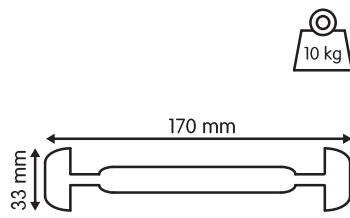

◎ **609-104**

Polyethylene (soft) handle.

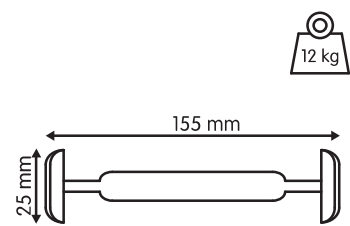

◎ **609-114**

Polyethylene (soft) handle.

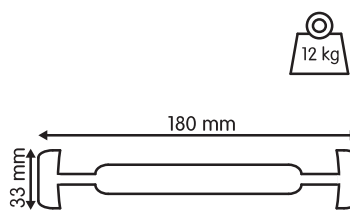

◎ **609-106**

Polyethylene (soft) handle.

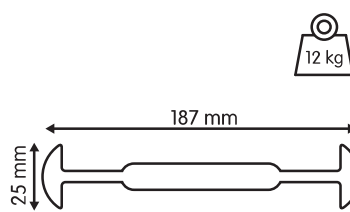

◎ **609-107**

Polyethylene (soft) handle.

08

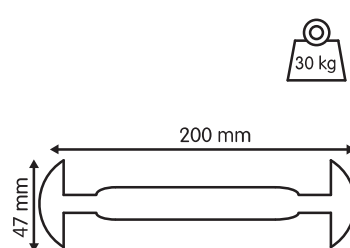

◎ **609-108**

Polyethylene (soft) handle.

◎ **609-109**

Polyethylene (soft) handle.

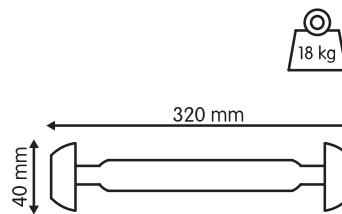

◎ **609-112**

Polyethylene (soft) handle.

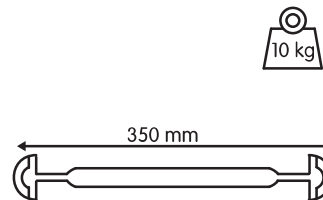

◎ **609-110**

White polyethylene handle.

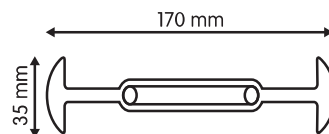

◎ **609-111**

White plastic handle with reinforcing plate.

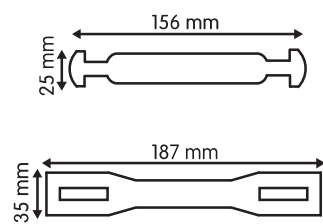

◎ **609-113**

Transparent white plastic handle with reinforcing plate.

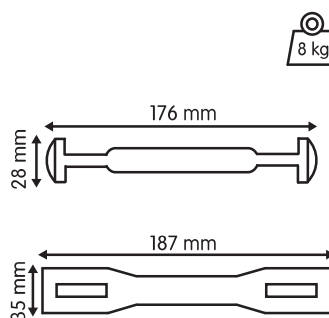

**MISCELLANEOUS**  
**CALENDAR ACCESSORIES**

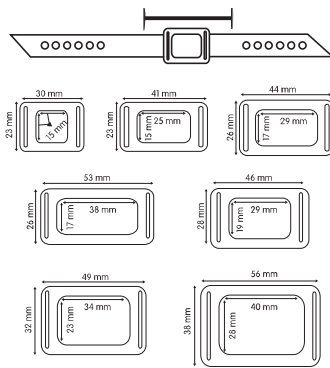

◎ **800-004**

Clear PVC date indicator with elastic (T-end).

**IMPORTANT INFORMATION:**

- \* calendar width
- \* window: 25 different sizes => see right page
- \* colour window: standard = red



◎ **800-001**

Clear PVC date indicator with elastic.  
**ON REQUEST (minimum 500 pcs).**











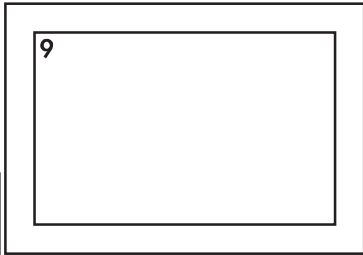
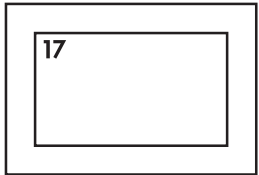
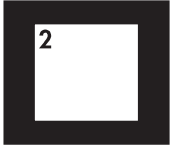

◎ **800-002**

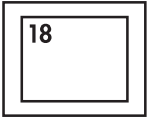
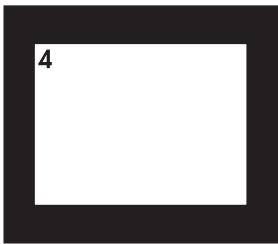
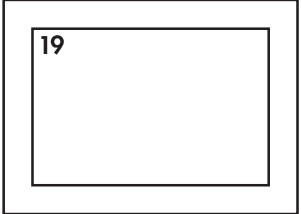
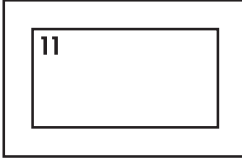
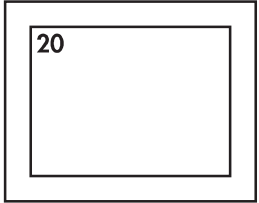
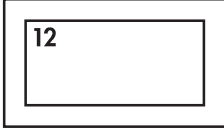
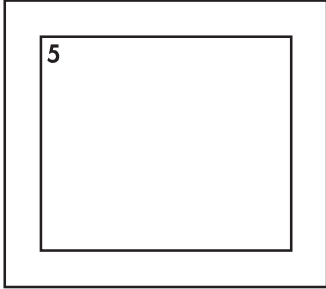
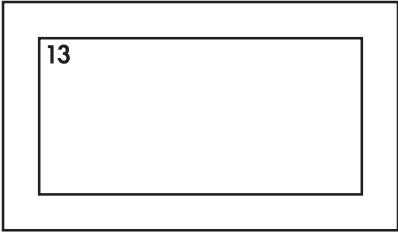
Clear PVC date indicator with elastic.  
 Block system: clamped around several pages. **ON REQUEST (minimum 500 pcs).**

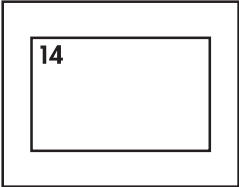

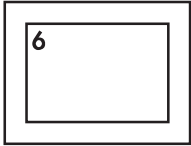
◎ **800-003**

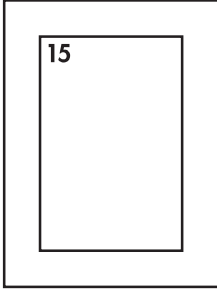
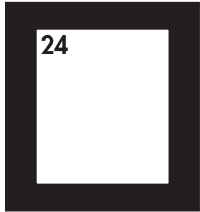
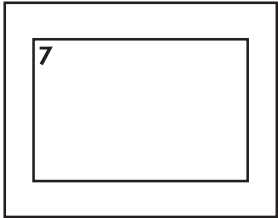
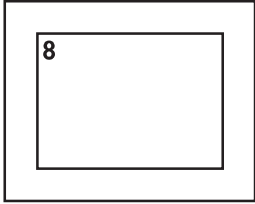
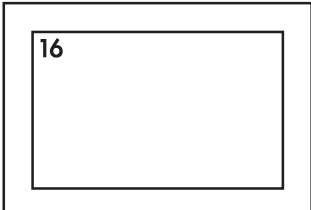
Clear PVC date indicator with elastic.  
 Page system: clamped around 1 page. **ON REQUEST (minimum 500 pcs).**

1.	INSIDE: OUTSIDE:	10 x 12 mm 16 x 18 mm			
2.	INSIDE: OUTSIDE:	14 x 15 mm 20 x 23 mm			
3.	INSIDE: OUTSIDE:	16 x 18 mm 24 x 26 mm			
4.	INSIDE: OUTSIDE:	23 x 30 mm 33 x 38 mm			
5.	INSIDE: OUTSIDE:	30 x 35 mm 40 x 45 mm			
6.	INSIDE: OUTSIDE:	14 x 20 mm 20 x 26 mm			
7.	INSIDE: OUTSIDE:	20 x 30 mm 30 x 38 mm			
8.	INSIDE: OUTSIDE:	19 x 26 mm 28 x 35 mm			
9.	INSIDE: OUTSIDE:	27 x 42 mm 35 x 50 mm			
10.	INSIDE: OUTSIDE:	17 x 38 mm 24 x 46 mm			
11.	INSIDE: OUTSIDE:	14 x 26 mm 22 x 34 mm			
12.	INSIDE: OUTSIDE:	12 x 25 mm 18 x 31 mm			
13.	INSIDE: OUTSIDE:	22 x 45 mm 32 x 55 mm			
14.	INSIDE: OUTSIDE:	16 x 25 mm 26 x 33 mm			
15.	INSIDE: OUTSIDE:	30 x 20 mm 40 x 30 mm			
16.	INSIDE: OUTSIDE:	22 x 35 mm 30 x 43 mm			
17.	INSIDE: OUTSIDE:	16 x 27 mm 24 x 35 mm			
18.	INSIDE: OUTSIDE:	12 x 15 mm 16 x 20 mm			
19.	INSIDE: OUTSIDE:	22 x 33 mm 30 x 41 mm			
20.	INSIDE: OUTSIDE:	21 x 28 mm 28 x 35 mm			
21.	INSIDE: OUTSIDE:	13 x 8 mm 20 x 15 mm			
22.	INSIDE: OUTSIDE:	8 x 10 mm 12 x 14 mm			
23.	INSIDE: OUTSIDE:	8 x 13 mm 12 x 18 mm			
24.	INSIDE: OUTSIDE:	22 x 19 mm 29 x 27 mm			
25.	INSIDE: OUTSIDE:	14 x 30 mm 17 x 38 mm			



# TERMS & CONDITIONS OF SALE

## 1. GENERAL

- 1.1 In these conditions 'The Company' refers to Index Plastics Limited and the 'Customer' refers to the purchaser of the goods.
- 1.2 The Customer agrees that the conditions set out below shall be incorporated into any contract with the Company.
- 1.3 Clerical errors may be corrected by the Company at any time
- 1.4 The waiver by The Company of any breach or default of these Terms shall not be construed as a continued waiver of that breach nor as a waiver of any subsequent breach of the same or any other provision.
- 1.5 If any clause or sub-clause of these Terms is held by a competent authority to be invalid or unenforceable the validity of the other clauses and sub clauses of these Terms shall not be affected and they shall remain in full force and effect.
- 1.6 The company reserves the right to change sale prices at any time. The Company Product Catalogue, Price List, Web Site and Terms and Conditions are published E&OE. Index Plastics Limited ©2009.

## 2. FORMATION OF CONTRACT

- 2.1 The order consists of an acceptance by The Company to supply the goods and or services upon The Company's terms and conditions here set out and shall, unless previously cancelled by The Company by written notice to The Customer, be deemed to be accepted upon receipt by The Company of The Customers' written or verbal instructions to supply goods and or services, by accepting delivery of any part of the Goods and or services.
- 2.2 Unless otherwise agreed in writing by a director of the Company these Terms and Conditions of sale which supersede any earlier Terms and Conditions of sale shall override any terms and conditions stipulated, incorporated or referred to by the purchaser whether in the order or in any negotiations preceding the formation of the contract.
- 2.3 The Customer's standard terms or any other terms provided by the Customer shall not be incorporated into the contract or any variation thereof less expressly accepted by the Company in writing.
- 2.4 These Conditions shall be deemed to be incorporated in every transaction by the Company to a customer or prospective customer for a Quotation, every Order and every Contract. Every Quotation and every acceptance or an Order by the Customer constitutes unconditional acceptance of the Conditions.
- 2.5 These Conditions shall apply to the contract to the exclusion of all Customer order terms and conditions on which any purchase order has been given to The Company or subject to when the order is accepted or purported to be accepted by The Company.
- 2.6 These Conditions shall prevail over, supersede and exclude any inconsistent terms or conditions contained in or referred to in a Customer's Purchase Order, Tender Document or Quote request, correspondence or elsewhere. No addition to the Conditions or any of them shall be binding upon the Company unless confirmed expressly and specifically by a director of the Company, in Writing.
- 2.7 Neither party shall be bound by any variation, waiver or addition or exclusion to the terms and conditions here set out unless agreed in writing between the authorised representative of The Company and The Customer.
- 2.8 The Company shall not be liable in respect of any misrepresentation made by The Company the Company servants or agents to The Customer its servants or agents as to the condition of the Goods their fitness for any purpose or as to quantity or measurements or weight loadings unless the representation is:
  - 2.8.1 made or confirmed in writing by The Company; and/or
  - 2.8.2 fraudulent
- 2.9 Without prejudice to clause 2.8 of these Terms while the Company take every precaution in the preparation of the Company catalogue price lists and other literature these documents are for the Customers general guidance only and statements made therein (in the absence of fraud on the Company part) shall not constitute representations by The Company and The Company shall not be bound by them. If The Customer requires advice in relation to the Goods a specific request for advice should be made and any advice made or confirmed in writing in response to such a request shall amount to a representation and The Company shall be liable accordingly. Due to differing surfaces and physical conditions the Company cannot give advice as to appropriate weight loadings for any item of the Goods. On request the Company shall provide samples for The Customer to test on site.
- 2.10 For the avoidance of doubt if The Customer is not dealing as a Consumer the Company liability for damages for misrepresentation (other than fraudulent) is excluded or limited by Clause 8 of these Terms. The statutory rights of a Consumer are not affected by these Terms.

## 3. QUOTATIONS

- 3.1 All prices are, unless otherwise stated, quoted exclusive of delivery costs and VAT. The Company reserves the right to be exercised at its discretion, to vary the price of goods, if, subsequent to the date of the quotation there is any increase or decrease in the total cost to the Company of producing or acquiring the goods which is beyond the Company's control.
- 3.2 In such an event the Company will give written notice to the Customer before delivery. If such alteration increases the price, the Customer may cancel the relevant order by notice given to the Company within 3 days of the date of the notification of the increase by the Company.

## 4. SAMPLES

The Company may at its discretion submit a sample to the Customer for approval before executing the bulk of the order, which will only be commenced on receipt of such approval in writing. All goods in respect of which is sampled is so approved shall be deemed to have been satisfactorily tested by the Customer and to comply with the specification for the goods.

## 5. WARRANTIES

- 5.1 The goods shall be of satisfactory quality and will conform to any specification agreed by the Company in writing, within the normal limits of industrial quality for such goods.
- 5.2 The liability of the Company for breach of the above term, or any claim in respect of any defect in the goods, shall be limited to replacement of the defective goods or, at the Company's option, reimbursement of the price paid for those goods.
- 5.3 The Customer shall not be entitled to make any claim in respect of any such defective goods unless the claim is notified to the Company in writing within 7 days from delivery of the goods.
- 5.4 The Company shall not be liable to the customer where the defect or damage in respect of which a claim is made has been caused or contributed to by:
  - 5.4.1 abnormal usage of the goods;
  - 5.4.2 an act or omission of anyone other than The Company.
- 5.5 Any particular purpose for which the goods are to be fit must be agreed in writing between the Company and the Customer. If no such agreement is made, the customer acknowledges and agrees that he has not made known expressly or by implication to the Company any particular purpose for which the goods are being bought.
- 5.6 Save as set out above:
  - 5.6.1 All terms relating to the quality of the goods or to the fitness to the goods for a particular purpose are excluded from any contract between the Company and the Customer.
  - 5.6.2 The Company shall be under no liability in respect of any defect in the goods.

## 6. LIABILITY

7.1 In no circumstances shall the Company's liability (in contract, tort or otherwise) in any matter arising out of or in connection with this contract of the goods supplied, exceed the invoice price of the particular

pieces concerned and furthermore the Company shall be under no liability for the loss or damage or delay howsoever arising, caused by circumstances outside its control.

- 7.2 In these Terms "the Defect" means the condition and/or any attribute of the Goods and/or any other circumstances which but for the effect of these Terms would have entitled the Customer to damages.
- 7.3 Nothing in these Terms shall exclude or restrict the Company liability for death or personal injury resulting from the Company negligence or the Company liability for fraudulent misrepresentation.
- 7.4 If the Customer deal as a Consumer any provision of these Terms which is of no effect shall not apply. The statutory rights of a Consumer are not affected by these Terms.
- 7.5 Subject to Clauses 7.3 and 7.4 of these Terms The Company shall not be liable by reason of any misrepresentation (unless fraudulent) or any breach of warranty condition or other term express or implied or any breach of duty (common law or statutory) or negligence for any damages whatsoever. Instead of liability in damages The Company undertake liability under Clause 7.6 below.
- 7.6 Where but for the effect of Clause 7.5 of these Terms The Customer would have been entitled to damages against The Company The Company shall not be liable to pay damages but subject to the conditions set out in Clause 8.6 below shall in the Company sole discretion either repair the Goods at the Company own expense or supply replacement Goods free of charge or refund all (or where appropriate part) of the price paid for the relevant Goods.
- 7.7 The Company will not be liable under Clause 7.6:
  - 7.7.1 if the Defect arises from fair wear and tear
  - 7.7.2 if the Defect arises from wilful damage negligence abnormal working conditions misuse alteration or repair of the Goods or storage of the Goods in unsuitable conditions (but this sub-clause shall not apply to any act or omission on the Company part)
- 7.8 Subject to Clauses 7.3 and 7.4 of these Terms The Company shall not be liable by reason of any misrepresentation (unless fraudulent) or any breach or warranty condition or other term express or implied or any breach of duty (common law or statutory) or negligence for any damages whatsoever (if notwithstanding Clause 7.5 of these Terms The Customer are entitled to recover any) nor shall The Company be liable under Clause 7.7 of these Terms unless:
  - 7.8.1 if the Defect would have been apparent on a reasonable inspection under Clause 6.1 of these Terms at the time of receipt written notice of any claim is given to The Company within one working day of the time of receipt; or in any other case
  - 7.8.2 The Defect is discovered within 28 days from the date of delivery and The Company are given written notice of the Defect within two working days of it being discovered
- 7.9 If the Goods are not manufactured by The Company the Company liability in respect of any defect in workmanship or materials of the Goods will be limited to such rights against the manufacturer as The Company may have in respect of those Goods. The Company will on written request provide details of the Company rights against the manufacturer and any other terms and conditions imposed by the manufacturer and so far as possible will on request assign to The Customer any such rights.
- 7.10 If The Customer are not dealing as a Consumer The Customer will unconditionally fully and effectively indemnify The Company against all loss damages costs on an indemnity basis and expenses awarded against or incurred by The Company in connection with or paid or agreed to be paid by The Company in settlement of any claim by any third party arising from the supply or use of the Goods including loss arising from the Company negligence.
- 7.11 Without prejudice to any other provisions in these Terms in any event the Company total liability for any one claim or for the total of all claims arising from any one act of default on the Company part (whether arising from the Company negligence or otherwise) shall not exceed the purchase price of the Goods the subject matter of any claim.

## 8 INTELLECTUAL PROPERTY

- 8.1 The Company is the owner of all copyright, design rights including patents, patents pending and registered designs in the products manufactured by the Company and these rights are not transferred with the sale of the goods and may not be reproduced by the Customer or any other third party. The Company vigorously protects its intellectual property in all cases. Any drawings or technical information provided by the Company to the Customer in the course of the Company business relationship is to be treated as confidential and may not be passed to any third party without prior authorisation from the Company. Such information must be returned on request.
- 8.2 Where the Customer have provided drawings and /or specifications to the Company for manufacture the Customer agree to indemnify the Company against all claims for infringement of any third party's intellectual property rights (including but not limited to: patents, trademarks, copyright, design rights) caused by accepting the Customers instructions to manufacture any item resulting in such a claim against the Company. If the Company have concerns about the provenance of any design the Company reserve the right to refuse the Customers order on both ethical and legal grounds.

## 10. DELIVERY

- 10.1 Time is not of the essence of the contract.
- 10.2 If the Company does not deliver the goods within 21 working days of the date stated for delivery on the order then the Customer may give written notice to the Company that delivery is required within a period of not less than 14 days, to be sent by recorded delivery. If the Company fails, without good reason, to commence delivery of the goods within the stated period then the Customer may cancel the order. In the event of such cancellation the Customer shall not be liable to pay any further sums in respect of goods which have not been delivered.
- 10.3 The Customer shall have no right to damages for any failure on the Company's part to deliver the goods in accordance with the time stated for delivery.
- 10.4 The Company reserve the right to make delivery by instalments and tender a separate invoice in respect of each instalment. The Company failure to deliver any one or more instalments or any claim by The Customer in respect of any one or more instalments shall not entitle The Customer to treat the Contract as a whole as repudiated.
- 10.5 Goods will be delivered by the Company by whatever method The Company consider to be suitable in the circumstances. Delivery charges are additional. Details are available on request and will be quoted when order is place if requested.
- 10.6 The Company aim to despatch stock Goods the day following acceptance of order or receipt of cleared funds in the case of non-account transactions however, delivery and despatch dates are given in good faith but are estimates only.
- 10.7 The Company shall not be liable for any damages whatsoever whether direct or indirect (including for the avoidance of doubt any liability to any third party) resulting from any delay in delivery or despatch of the Goods or failure to deliver the Goods in a reasonable time whether such delay or failure is caused by the Company negligence or otherwise howsoever.
- 10.8 Whilst The Company shall make every endeavour to deliver the quantity of goods ordered, nevertheless a delivered quantity of 10% more or less than the quantity ordered shall be deemed to be due execution and performance of the Contract, the price being increased or reduced pro rata accordingly.

## 11. INSPECTION AND ACCEPTANCE.

- 11.1 If the Customer wishes to inspect the goods prior to delivery, such inspection must be made at the Company's premises and notification of this requirement must be given in writing at the time of placing the order. If upon inspection goods are approved by or on behalf of the Customer then such approval shall constitute acceptance by the customer that the goods conform with their specification and that the goods are fit for any particular purpose agreed under clause 4.



11.2 If no such inspection is made then, unless the Customer gives written notification to the contrary to the Company within 3 working days after delivery, the Customer shall be taken to have approved the goods and to accept that the goods conform with their specification and that the goods are fit for any particular purpose agreed under clause 4.

11.3 The Customer shall inspect the Goods at the time of receipt but nothing in these Terms shall require The Customer to break packaging and/or unpack Goods which are intended to be stored before use.

11.4 The Customer must telephone or fax The Company as soon as practicable and give The Company written notice within two working days of receipt of any claim for short delivery.

11.5 If The Customer do not give The Company that notice within that time the Goods will be deemed to have been delivered in the quantities shown in the delivery documents.

11.6 The Customer shall not be entitled and irrevocably and unconditionally waive any right to reject the Goods or claim any damages whatsoever for short delivery howsoever caused.

11.7 The Company liability for short delivery is limited to making good the shortage.

11.8 Where it is or would have been apparent on a reasonable inspection that the Goods are not in conformity with the Contract or (where the Contract is a contract for sale by sample) that the bulk does not compare with the sample The Customer must give the Company written notice, telephone or fax the Company as soon as practicable and give the Company written notice within two working days.

11.9 If the Customer are not a Consumer and The Customer fail to give The Company that notice within that time the Goods will be deemed to have been accepted and The Customer shall not be entitled and irrevocably and unconditionally waive any right to reject the Goods.

11.10 If the Customer are not a Consumer and The Customer fail to give The Company that notice within that time Clause 7.8 shall have effect.

## 12. SPECIFICATION.

12.1 All drawings, descriptions, specifications and particulars of the goods to be supplied are approximate only.

12.2 The descriptions and illustrations contained in the catalogues, price lists and other advertising of the Company have been provided in good faith by the Company but:

12.2.1 No such description, illustration, price list or other advertising shall form part of the contract;

12.2.2 If the Customer wishes to rely on any such description, illustration, price list or other advertising in entering into the contract it must notify the Company in writing before the Company provides a quotation. If no such notification is given, the Customer agrees that it did not rely on any such representation in entering into the contract.

12.3 The Company reserves the right to incorporate new features and to supply products which may not be strictly in accordance with the specification agreed upon, provided that any changes in specification shall not materially prejudice the performance of the goods.

## 13. QUANTITIES

13.1 The quantity of the goods ordered shall be subject to fluctuation of plus and minus 10%. In the case of such fluctuation, an appropriate adjustment shall be made to the price.

13.2 A receipt in respect of the delivery must be signed on receipt of the goods by the Customer or his representative at the Customers premises. Unless the Customer notifies the Company in writing of any shortfall within 48 hours of delivery, the Customer is taken to accept that the correct quantity has been delivered. The Company will have no liability for any shortfall and will be entitled to payment for the full quantity.

## 14. PRICE

14.1 The price of Goods exclusive of carriage and VAT shall be as at the date of delivery of the Goods. Prices are subject to change without prior notice.

14.2 Items marked N/A or P.O.A. on the Company's web site or in its printed price list are normally not available in the quantity price band shown because as a stock item of low value/small quantity it would not be practical to split packs or as a non-stock item they have to be imported or made to order and minimum quantity requirements apply. The Company may, on request, consider whether the Company is able to accept an order.

14.3 Items not indicated on the Company web site or catalogue illustrations as stock will only be supplied if the quantity required is sufficient to justify either manufacture or importation.

## 15. NON-PAYMENT/INSOLVENCY

15.1 "Insolvent" means The Customer becoming unable to pay its debts within the meaning of Section 123 of the Insolvency Act 1986; the levying or the threat of execution of distress on any of its property; the appointment of a receiver or administrative receiver over all or any part of its property; a proposal for a voluntary arrangement or compromise between The Customer and its creditors whether pursuant to the Insolvency Act 1986 or otherwise; the passing of a resolution for voluntary winding-up or summoning a meeting to pass such a resolution otherwise than for the purposes of a bona fide amalgamation or reconstruction; the presentation of a petition for the Customers winding-up or for an administration order in relation to The Customer; if the Customer suffer any analogous step or proceedings under foreign law or The Customer ceasing or threatening to cease to carry on its business.

15.2 If the Customer fail to pay the price for any Goods on the due date or The Customer become Insolvent or if The Customer are a Limited Company there is a material change in the Customers constitution or The Customer commit a material breach of this Contract and fail to remedy that breach all sums outstanding between The Customer and The Company shall become immediately payable and The Company shall be entitled to do any one or more of the following (without prejudice to any other right or remedy The Company may have):-

15.2.1 require payment in cleared funds in advance of further deliveries

15.2.2 cancel or suspend any further deliveries to The Customer under any contract without liability on the Company part

15.2.3 charge interest on the balance of monies outstanding at the rate of 8% over the current base rate prevailing in England from the date the payment became due until actual payment is made after as well as before judgement.

15.2.4 without prejudice to the generality of Clause 7 of these Terms exercise any of the Company rights pursuant to that clause.

15.2.5 recover from The Customer all costs and expenses, including legal costs on an indemnity basis, incurred by The Company in taking steps to enforce the Company rights under this or any other clause of these Terms.

## 16. PAYMENT

16.1 Payment for the goods must be made within 30 days of the date of the invoice.

16.2 In the event of non-payment within 30 days, then the Company may charge interest on all unpaid sums at a rate of 8% over the current base rate prevailing in England.

16.3 The Company does implement it's statutory right to interest.

16.4 Payment terms are strictly within the Company sole discretion which the Company may exercise on receipt of each order either:-

16.4.1 **Cash with order:** orders will not be processed until payment in full for Goods packaging carriage and VAT has been received by The Company in the form of cleared funds;

16.4.2 **Credit card sales:** Orders will not be processed until credit clearance has been received;

16.4.3 **Account terms:** payment is due no later than thirty days from the date of invoice.

16.5 The Company reserves the right to refuse to execute any order or contract if the arrangements for payment or the customer's credit are not satisfactory to The Company and in the Company's sole

discretion The Company may require payment for each consignment when it is available and before it is dispatched in which case delivery will not be effected until The Company are in receipt of cleared funds.

16.6 In the case of short delivery The Customer will remain liable to pay the full invoice price of all Goods delivered or available for delivery.

16.7 The Customer may not withhold payment of any invoice or other amount due to The Company by reason of any right of set off or counterclaim which The Customer may have or allege to have for any reason whatever.

## 17. STERLING PROTECTION

Where it is agreed that payment for the goods is to be made in any currency other than £ sterling the Company reserves the right to be exercised at it's discretion to vary the price so as to take into account any changes in the rate of exchange between the date of the Company's quotation and the date of the invoice.

## 18. RETURNS

Goods can only be returned if written authorisation has been received from the Company. The goods must be in their original cartons and unopened. Opened or incomplete cartons will not be accepted. A restocking charge of £25 will be made and any credit issued will exclude any carriage, P&P or freight charges originally invoiced and/or paid for. Custom made or modified products are non returnable. No returns of any nature will be accepted after 60 days from despatch date.

18.1 The Goods shall be stored separately from any other goods and The Customer shall not interfere with any identification marks label batch numbers or serial numbers on the Goods.

18.2 The Company agree that The Customer may use or agree to sell the Goods as principal and not as the Company agents in the ordinary course of the Customers business subject to the express condition that at the Company direction the entire proceeds of any sale or insurance proceeds received in respect of the Goods are held in trust for The Company and not mixed with any other monies or paid into an overdrawn bank account and shall at all times be identifiable as the Company money.

18.3 The Company shall be entitled to recover the price of the Goods including VAT even though the property in any of the Goods remains with The Company.

18.4 The Company shall be entitled at any time to recover any or all of the Goods in the Customers possession to which The Company have title and for that purpose The Company the Company servants or agents may with such transport as is necessary enter upon any premises occupied by The Customer or to which The Customer have access and where the Goods may be or are believed to be situated.

## 19 RISK AND TITLE

19.1 Risk in the goods shall pass to the Customer on delivery.

19.2 The property in the Goods shall remain with The Company until full payment for all goods has been received by the Company.

19.3 Property in all goods shall remain with the Company, notwithstanding delivery of the goods or any part of them;

19.3.1 Until title passes:-

19.3.2 The Customer shall be at liberty to sell or deal with the goods in the ordinary course of business, but until full payment in respect of all goods has been made;

a) The Customer shall hold the Goods as the Company fiduciary agent and bailee

c) The Customer shall hold the proceeds of any sale of the goods as trustee for the Company. The proceeds shall not be mingled with other monies or paid into any overdrawn bank account and such monies shall at all times be identifiable as the Company's monies. The Customer as trustee for the Company shall not be entitled to deal with such monies in any manner whatsoever.

19.4 The Customers power to sell or deal with the goods in the ordinary course of business shall be automatically revoked if the Company cancels the order under clause 22 below.

19.5 Upon determination of the Customers power of sale, the Company shall be entitled to reclaim the goods and the customer grants the company a license to enter the Customers premises for that purpose.

## 20. CANCELLATION

20.1 If at any time the Customer cancels an order for goods or services which do not appear in the Company's most recent catalogue or which are, in the Company's opinion non standard, then the Company shall be entitled to claim an amount up to 85% of the value of the order, as liquidated damages for stock. The Customer agrees that the said amount represents a genuine pre-estimate of the Company's loss. The said sum shall be recoverable by the Company from the Customer as a debt.

20.2 Cancellations for goods deemed as bespoke, custom, production or non standard in other way, will only be accepted at the company's discretion and the Customer must notify the Company immediately by telephone and confirmation made in writing.

20.3 In the event of cancellation of any order the Customer will be liable for the cost of any tooling, materials committed to, labour undertaken and committed to up to the time of cancellation and any other cost associated with the cancelled order that the Company has or will incur as a result of the commitment made.

20.4 If the Customer fails to make the correct payment to the Company for the products by the date on which any such payment is due, or makes a composition or arrangement with his creditors, or becomes bankrupt or being a company makes a proposal for a voluntary arrangement for a composition of debts or scheme of arrangements to be approved in accordance with the Companies Act 1985 or the Insolvency Act 1986 as the case may be or any amendment or re-enactment thereof, or has a provisional liquidator appointed or has a winding up order made or passes a resolution for voluntary winding up or under the insolvency Act 1986 or any amendment or re-enactment thereof has an administrator or an administrative receiver appointed then:

20.4.1 The Customer shall immediately inform the Company;

20.4.2 The Company may by notice in writing to the Customer cancel the order any other orders which may be outstanding between the Customer and the Company.

20.5 In the event of such cancellation:

20.5.1 The Company shall be entitled to reclaim the goods in accordance with the provisions of clause 21 above; and

20.5.2 The Customer shall remain liable to pay the Company the full purchase price for the goods less (i) the disposal value received by the Company for the whole or part of the goods in its possession or reclaimed by the Company under paragraph 14 above (ii) any part of purchase price for the goods paid by the Customer to the Company and (iii) any direct costs incurred by the Company in the performance of the order. The Company's determination of such amount shall, in the absence of manifest error, be binding on the Customer.

## 21. FORCE MAJEURE

The company shall not be liable to the Customer for failure to deliver the goods or for any delay in delivery of the goods or for any damage to or defect in the goods where such failure is caused or contributed to by any cause outside the Company's reasonable control, including but not limited to shortages of raw materials, industrial action, riots and civil commission or acts of God, theft, water and embargo.

## 22. LAW AND JURISDICTION

These conditions are governed by English Law. Any disputes shall be submitted to the exclusive jurisdiction of the English courts.