

Downstream Pressure Control

Section Four

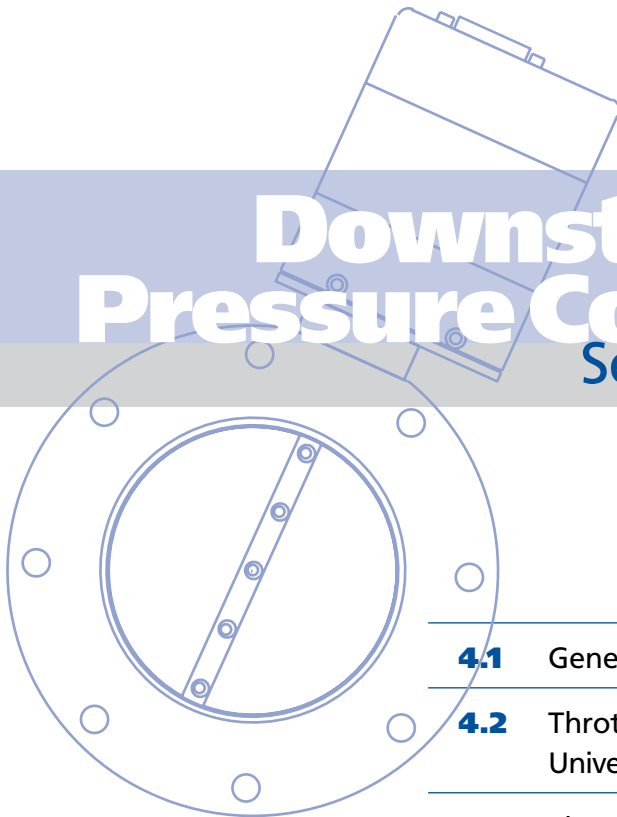

4

4.1	General Information	2
4.2	Throttling Butterfly Valves & Universal Valve Drives	4
4.3	Throttle Valve Heaters	10
4.4	Throttling Pendulum Valves	11
4.5	Throttling Soft Shut Gate Valves	16
4.6	Adaptive Pressure Controllers	19
4.7	Capacitance Diaphragm Gauges	21
4.8	Accessories and Spare Parts	26

Nor-Cal Products Asia Pacific Pte Ltd
2 Ang Mo Kio Street 64
#01-03A ECON Industrial Building
Singapore 569084

Tel: **+65-9199-1899**
Fax: **+65-6634-1008**
www.n-c.com

Nor-Cal Products, Inc.
1967 South Oregon Street
Yreka, CA 96097 USA

Tel: **800-824-4166**
or 530-842-4457
Main Fax: 530-842-9130
Sales Fax: 530-841-9189
www.n-c.com



Intellisys™

ADAPTIVE PRESSURE CONTROL COMPONENTS

New Products

Intellisys Next Generation IQ+ Controller

Responding to emerging industry requirements, Nor-Cal now has a fully RoHS compliant and DeviceNet certified adaptive pressure controller called the IQ+. It is similar in function and appearance to the earlier line of IQ-controllers, but features a much advanced pressure control algorithm for improved control during difficult conditions. The IQ+ on-board controller can be used with most throttle valves and it offers a popular fail safe battery backup option and add-on gauge power.



Capacitance Diaphragm Gauges

Nor-Cal proudly announces the availability of ultra stable ceramic sensor gauges featuring digital circuitry, one push button zero and a convenient service port. The gauges exhibit second-to-none short and long term stability, shorter warm-up times and excellent recovery from atmospheric bursts.

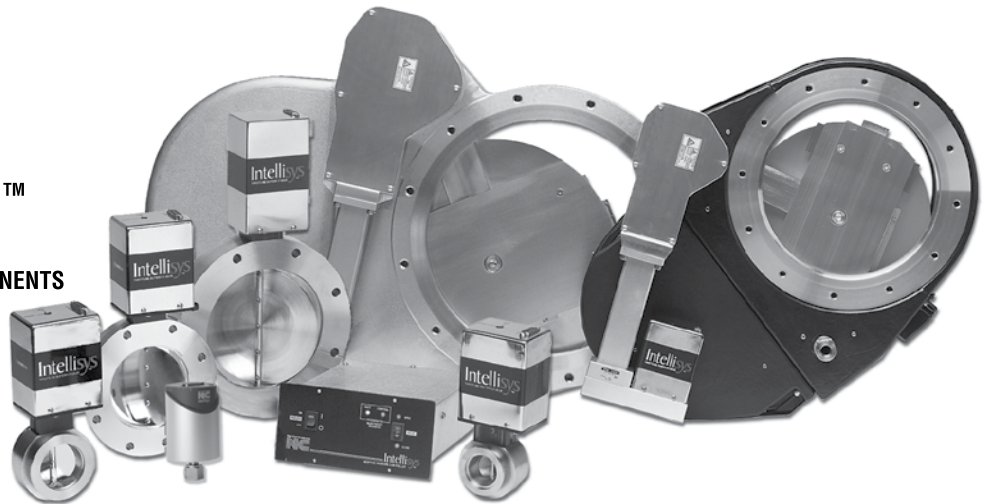

Intellisys - The Fastest, Most Precise Pressure Control System

Nor-Cal Products offers unequalled performance with the Intellisys downstream pressure control products, providing measurable process benefits through higher resolution, speed and reliability. These benefits are the direct result of two core functions embedded in all Intellisys control systems.

First, a unique patented closed-loop motor control technology, which is a combination of electronics hardware and software, resides in every Intellisys controller. This allows Intellisys control valves to be operated at high rates of speed and with extremely fine positional resolution, while using standard off-the-shelf stepper motors.

Second, capitalizing on the high motor speed and fine resolution is an adaptive pressure control algorithm that yields near flawless pressure control performance over a wide range of system conditions without the need to "tune" or "learn" PID parameters.

Adding to the pressure control system benefits is a host of valve functions and features aimed at optimizing control performance and reliability. These include the selection of direct driven valves that eliminate the use of costly and unreliable gear heads or belt drives. Furthermore, none of the Intellisys control valves rely on mechanical or optical switches to determine the valve stroke end-points. Instead, bulletproof hard stops that are sensed by the closed-loop motor position feedback signals serve as the open and closed indicators. Last, all Intellisys control valves, regardless of type, have been designed with controllability and conductance in mind.

Optimally designed throttle plates and actuation mechanisms therefore provide an essential contribution to the overall behavior and performance of the downstream pressure control system.

Products

Every complete downstream pressure control system design incorporates three components including a throttle valve, valve controller and pressure (vacuum) gauge. Nor-Cal Products has products available in all of these categories.

The selection of throttle valves includes families of butterfly, pendulum, and gate valves. The choice of valve depends on the intended application, but each is available in a wide range of sizes and flange types with many optional functions and features, and all of them feature the closed-loop motor control capability that results in high speed and ultra-fine resolution. In addition, Nor-Cal offers the Universal Valve Drive (UVD) – a motor drive product that can be tailored to fit most other manufacturers' valves. Doing so can greatly improve pressure control performance characteristics of existing valves at a reduced cost.

Adaptive pressure controllers are available for each type of valve or valve drive, and generally come in two styles. The stand-alone buried box controllers are ideal for applications where expanded communications or user interfaces are desired. For installations where installation space is of concern, the on-valve IQ-series controllers may be a preferred choice. Regardless of type, all Intellisys controllers are powered by Digital Signal Processors (DSP) and have many available host communications

interfaces such as RS-232, RS-485, DeviceNet, and Analog/TTL.

Nor-Cal capacitance diaphragm gauges (CDG) feature an ultra-stable ceramic diaphragm and advanced digital circuitry in all unheated and heated models. The gauges are available in all common ranges and can be supplied with most popular pipe fittings and connector types.

Intellisys Technology

Many users want to know more about the underlying closed-loop control technology that forms the backbone of Intellisys control systems. Whereas the finer details of this technology are, for obvious reasons, closely guarded, Nor-Cal is still happy to provide educational material for the sake of eliminating some of the "mystique" surrounding the technology or simply satisfying anyone's curious mind. To this end, the following page contains excerpts from a feature article that was written for and published by Semiconductor International magazine. Also, please visit us on the web at www.n-c.com or give our Intellisys technical support staff a call at **800-824-4166**.



Increase Vacuum Processing Throughput and Yield Using Advanced Downstream Pressure Control Methods

Vacuum process tool throughput and yield rates can be significantly affected by the performance level of chamber pressure control. Faster step transitions and more precise pressure control are often desired or needed to enhance tool productivity or increase production yields.

The Intellisys technology revolves around a new method of operating a variety of stepper motor driven downstream control valves (such as butterfly, poppet, gate and pendulum). In essence, it combines closed loop stepper motor control with an advanced pressure control algorithm allowing such valves to be controlled in ways never before possible. As a result of the exceptionally fast valve actuation and ultra-high position resolution, throughput increases up to 15% coupled with significant yield improvements and 100-fold scrap reduction have been realized saving vacuum processors millions of dollars per year.

Throttle Valves & Control Systems

One common method of controlling pressure in vacuum chambers is downstream pressure control. Downstream pressure control generally works well over a wide range of conditions, but its effectiveness can be challenged by "external" factors such as the sudden changing of inlet gas flowrates or the turning on or off of plasma events. Furthermore, certain flow- and pressure combinations can force the throttle valve to operate in a position at or beyond the limit of its intended control range. In such instances neither accurate nor repeatable pressure control may be feasible. Alternatively, pressure control may be feasible but not in a fast and efficient manner. As a result semiconductor wafer yield and throughput suffer.

Existing Technology - At present, throttle valves are available from a host of manufacturers and tool OEMs. As different as the various valves may be, almost all possess one common characteristic – that they are driven by stepper motors. Conventional motor drive technology involves sequencing the stepper motor through a prescribed combination of motor winding currents designed to guide the motor to move in a given direction using the desired number of steps. Referring to Table 1, we can see a typical sequence for a bipolar full step moving sequence.

From any given position (step), the motor can be moved to an adjacent position by changing the current going to the four respective drive phases (A, A', B and B'). Knowledge about the actual position is in these cases done by incrementing a step- or pulse-counter. This is referred to as open-loop motor control. Unfortunately, the speed and resultant position accuracy with which conventional open-loop stepping can be done is negatively influenced by non-linear effects from the valve and the motor drive assembly. Examples of such effects include inertia, friction, and backlash. As a result (and in comparison to what it could be) open-loop motor operation and positioning is by design sluggish.

Table 1: Bipolar Full Step Phase Sequencing

STEP	A	A'	B	B'
1	+	-	-	+
2	-	+	-	+
3	-	+	+	-
4	+	-	+	-
1	+	-	-	+

Improved Method - Motor control performance can be greatly improved by employing some means of true position feedback. By accurately tracking position, the user is no longer forced to be as conservative with respect to the acceleration or speed used in operating the motor. In addition to using the position feedback signal to determine the actual position, a position error term (target position less observed position) can easily be calculated, monitored and used to alter the amount of current delivered to the motor so as to overcome variations in external inertia and friction. This is what is referred to as closed-loop motor control, and it enables the motor to be driven to its full torque-speed potential. Since the knowledge of position can only be as accurate and timely as is the means by which the

true position is obtained, it is important to use a feedback sensor with a high enough resolution and accuracy. It is also imperative to synchronize the reading of position with the commanded position, lest the position error term cannot be accurately calculated. It is because of the challenges associated with the achievable resolution and synchronization that Nor-Cal Products' Intellisys line of valves and controllers employ the back EMF generated by the motor itself as a means of determining its position.

Effects on Pressure Control

The enhancements in the motor and valve drive technology as have been discussed up to this point would have little importance if they could not be tied to quantifiable improvements in pressure control. A live test was designed and conducted in order to illustrate and quantify any possible benefits of using higher speed and higher position resolution valve drive technology, such as in the case with a direct drive butterfly valve using back EMF position sensing. A multi-step wafer recipe was executed in a 35 liter chamber outfitted with throttling valve in the downstream position.

The Benefits of Speed – As can be seen in Figure 1 the first notable event occurs in the pressure transition step in which the pressure set-point is suddenly increased. As each of the three controllers drives their respective valves completely closed, the chamber pressure rises accordingly. The Intellisys valve closes completely in 0.125 seconds, as compared to 1.7 and 2.0 seconds of System 1 and 2, respectively. The result is an immediate onset of pressure rise allowing the set point to be reached that much faster.

Further contributing to the slower time to set point is System 2's gradual ramp toward set-point. The valve's relatively low speed necessitates a slow approach

to set-point, lest significant pressure over-shooting would occur.

The Benefits of Resolution – Ultrafine step resolution, such as that which can be achieved through back EMF position sensing, can play a very important role in the ability to control pressure at all. This benefit is especially noticeable in large valves that are also sealing valves – such as throttling gate and pendulum valves.

Figure 2 shows a comparison between two ISO-200 sealing throttling pendulum valves. In this diagram, the Intellisys system uses back EMF as the position sensing mechanism. System 3 uses standard open-loop type motor control. As is illustrated by the chart, almost indistinguishable moves by the Intellisys valve plate result in smooth pressure control at 1000 mbar. In contrast, a significant amount of "hunting" is evidenced by the System 3 valve, which in this case translates in to 50 to 60 mbar pressure swings. When occurring in critical processes or at sensitive times within a process, pressure swings such as these can have a dramatic and detrimental effect on the uniformity and yield of the wafer.

It has been shown how open-loop motor control differs from closed-loop motor control, and specifically how back EMF can be used to provide an unparalleled method for motor position feedback. Because of the high precision and resolution of such feedback mechanisms, ordinary stepper motors can be employed in ways not possible by conventional means. The advancements in motor control capabilities were then substantiated by demonstrating how cluster tool throughput and wafer yield can positively be impacted by the resultant improvements in pressure control.

Figure 1: Pressure Transition Using 100 mm Butterfly Valves

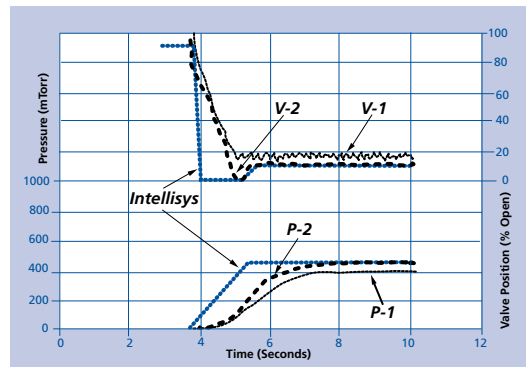
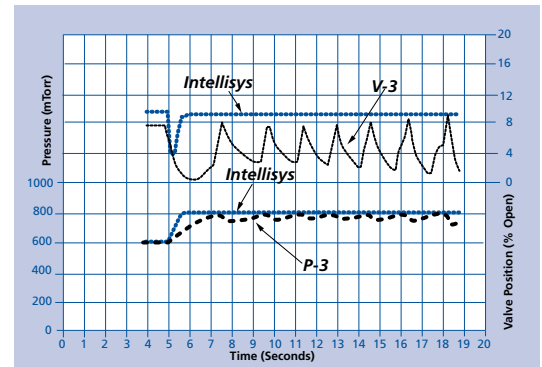

Figure 2: Pressure Control Stability Using 200 mm Pendulum Valve



Downstream Pressure Control Throttling Butterfly Valves



High actuation speed and ultra-fine position resolution

The Intellisys throttling butterfly valves (TBV) are available in a wide range of sizes and flange types and come standard with compact and low cost direct drives. More powerful geared drives are available as an option. Both styles use long time proven and reliable off-the-shelf stepper motors that deliver smooth operation, high actuation speed and ultra-fine position resolution. Intellisys TBVs are non-sealing and are therefore not suitable as isolation valves.

When combined with an Intellisys controller, the fast response Nor-Cal TBVs enable vacuum systems to reach process pressures sooner, reducing cycle time and increasing throughput. Furthermore, the high precision valve movement assures pressure control accuracy at 0.25% of set point, and often well within. Available controllers for TBVs include the buried box APC-family and, in most cases, the on-valve IQ and IQ+ series.

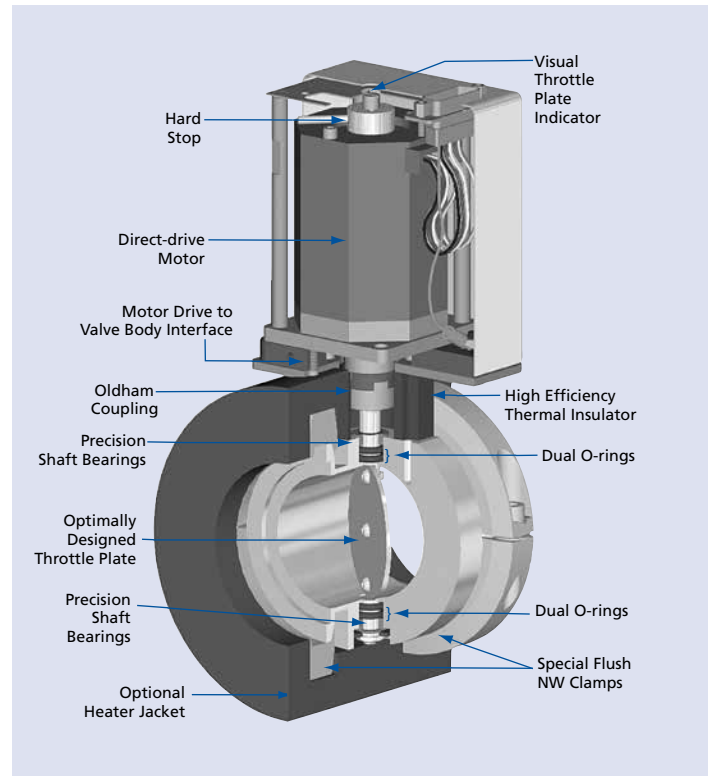

Features and Benefits

- Higher system throughput
- Optimally designed throttle plate for improved controllability
- Smallest footprint available
- Direct drive motor for more compact and reliable design
- Fully serviceable valve motor subassembly
- 316 stainless steel and Viton seals on all wetted parts. Other seal materials are available.
- High open conductance
- Low closed conductance



Universal Valve Drive (UVD)

Universal Valve Drives (UVD) can be used to retrofit and upgrade other manufacturers' valves, including butterfly, vane, flapper and other ¼- or ½-turn valve types. The resulting performance often comes close of that of a standard Intellisys system but at a fraction of the cost. Drive-to-valve adapters for most manufacturers have already been designed, and others can be easily made upon request. The UVD is currently only available with a geared drive.

UVD90-G — Specific Mating Valve Details

Please call with mating valve information such as: manufacturer, shaft diameter, adapter configuration, etc.

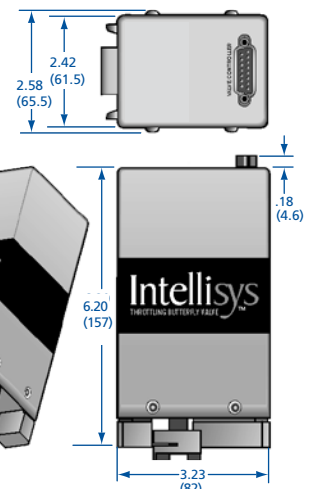

All dimensions are in inches (mm) & weights are in pounds (kg), unless otherwise noted.



Direct Drive Throttling Butterfly Valves

MODEL NUMBER	NOMINAL ID	FLANGE TYPE	A	B	C	D	WEIGHT
TBVP-D-100-NW-25	1 (25)	NW-25	2.25 (57.1)	2.75 (69.8)	6.68 (169.7)	6.99 (177.6)	5.5 (2.5)
TBVP-D-150-NW-40	1.5 (38)	NW-40	2.25 (57.1)	2.75 (69.8)	6.68 (169.7)	1.39 (35.3)	5.3 (2.4)
TBVP-D-200-NW-50	2 (50)	NW-50	2.00 (50.8)	3.36 (85.3)	6.99 (177.5)	1.98 (50.3)	5.5 (2.5)
TBVP-D-250-ISO-63	2.5 (63)	ISO-63	1.00 (25.4)	5.12 (130.0)	7.44 (189.0)	2.44 (62.0)	7.5 (3.4)
TBVP-D-300-ISO-80	3 (76)	ISO-80	1.00 (25.4)	5.71 (145.0)	7.76 (197.1)	2.94 (74.7)	8.8 (4.0)
TBVP-D-400-ISO-100	4 (100)	ISO-100	1.00 (25.4)	6.50 (165.1)	8.19 (208.0)	3.85 (97.8)	9.5 (4.3)

Gear Drive Throttling Butterfly Valves

MODEL NUMBER	NOMINAL ID	FLANGE TYPE	A	B	C	D	WEIGHT
TBVP-G-600-ISO-160	6 (150)	ISO-160	1.62 (41.1)	8.90 (226.1)	10.5 (266.7)	5.67 (144.0)	21.8 (9.9)
TBVP-G-800-ISO-200	8 (200)	ISO-200	1.62 (41.1)	11.2 (284.5)	12.5 (317.5)	7.87 (199.9)	28.5 (12.9)
TBVP-G-1000-ISO-250	10 (250)	ISO-250	1.62 (41.1)	13.2 (335.3)	13.5 (342.9)	9.88 (250.9)	38.0 (17.3)

SPECIFICATIONS

General

Compatible Controllers:
Direct drive: 200-series
Gear drive: 100-series buried box
Valve position: Visual indicator

Construction

Wetted materials: 316 stainless steel, seal material (see below)
Seals: Viton standard. Kalrez, Chemraz, Perlast and other materials available on request.

Operation

Motor power input: Supplied by BQC controller.
Differential pressure: 1.1 bar maximum across the valve plate
Forced heating capabilities: Valves may be heated up to 200°C with optional external heaters, provided seal and coupling material is specified to handle such temperatures.
Process gas temperature capabilities: For process gas temperatures in excess of 100°C, please consult with Nor-Cal Intellisys technical support for proper selection of seal materials and other design considerations.
Ambient operating conditions: 0 - 60°C @ 0 - 95% humidity
Leak rate: 1 x 10⁻⁹ mbar-liter/sec He

Inherent performance

Maximum speed: Open to closed in 125 msec (*direct*), 250 msec (*geared*)
Control resolution: 3.2 arc second (*direct*), 0.2 arc second (*geared*)
Maximum torque: 280 in-oz (*direct*), 2100 in-oz (*geared*)

Pressure Control Performance (when used with an Intellisys controller)

Accuracy: The greater of 5 mV or 0.25% of reading
Repeatability: Within 2.5 mV or 0.12% of reading
Control range: 0.5% - 100% of the vacuum gauge range

Reliability

(99% confidence level, in clean environment)
O-ring cycle life: 5 million open-close cycles
MTBF: >50,000 hrs. continuous operation

Approvals

CE (EMC and machinery directives)

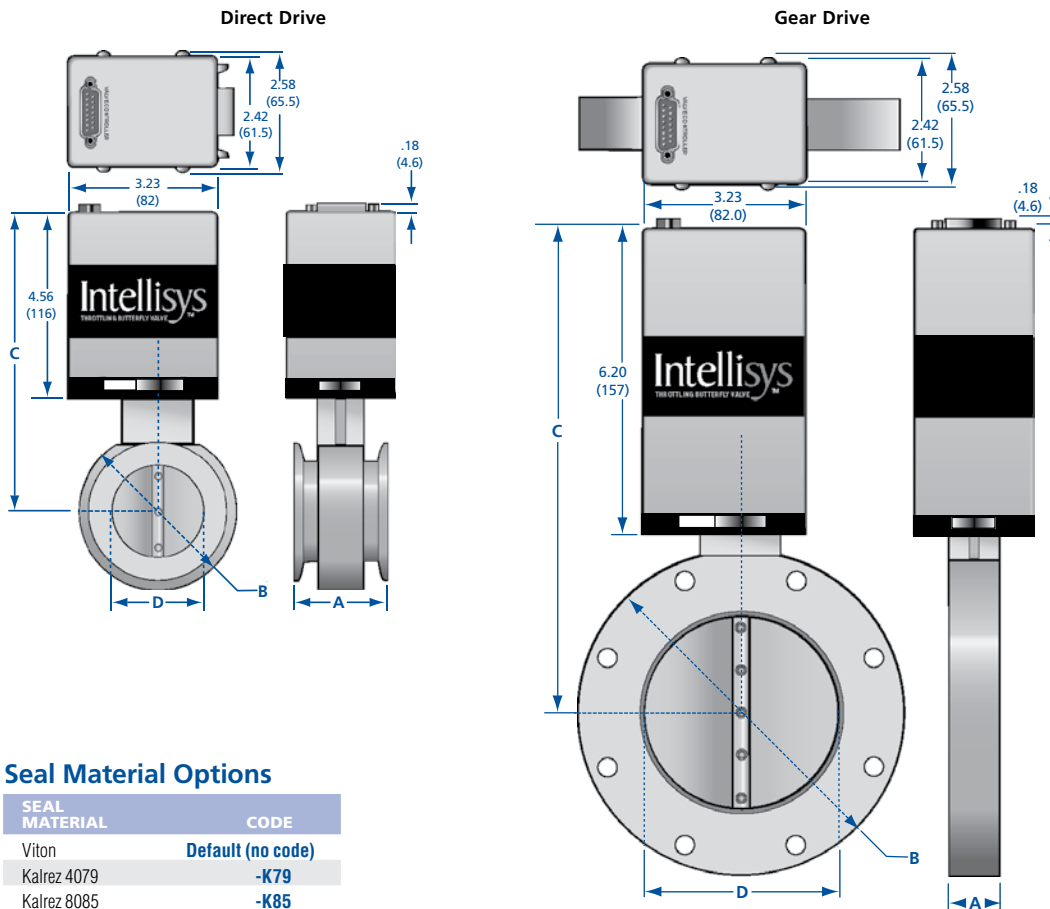

Seal Material Options

SEAL MATERIAL	CODE
Viton	Default (no code)
Kalrez 4079	-K79
Kalrez 8085	-K85
Kalrez 8575	-K75
Kalrez 9100	-K91
Chemraz E38	-C38
Dupra 192	-D19
Perlast G74P	-PP7

Example: TBVP-G-600-ISO-160-K75
 Gear drive TBV with 6 inch bore, ISO 160 flanges and Kalrez 8575 O-rings.

All dimensions are in inches (mm) & weights are in pounds (kg), unless otherwise noted.



SPECIFICATIONS

General

Controller Options:

IQA: Analog/TTL/RS232 interface
 IQD: DeviceNet/RS232 interface
 IQD2: DeviceNet/RS232 interface, no power via DN connector
 IQE: Ethernet/RS232 interface
 IQR: RS485 interface

Value position: Visual indicator

Construction

Wetted materials: 316 stainless steel, seal material (see below)

Seals: Viton standard. Kalrez, Chemraz, Perlast and other materials available on request (see below)

Operation

Power input: +24 VDC

Differential pressure:

1.1 bar maximum across valve plate

Forced heating capabilities:

Valves may be heated up to 150°C with optional external heaters.

Process gas temperature capabilities:

For process gas temperatures in excess of 100°C, please consult with Nor-Cal Intellisys technical support for proper design considerations.

Ambient operating conditions:

0 - 60°C @ 0 - 95% humidity
Leak rate: 1×10^{-9} mbar-liter/sec He

Inherent performance

Open to close speed: 125 msec

Control resolution: 3.2 arc second

Maximum torque: 1 in - 4 in : 280 in-oz

Maximum torque: 6 in - 10 in : 700 in-oz

Pressure control performance

Accuracy: The greater of 5mV or 0.25% of reading

Repeatability: Within 2.5mV or 0.12% of reading Control range: 0.5% - 100% of the vacuum gauge range

Reliability (99% confidence level, in clean environment)

O-ring cycle life: 5 million open-close cycles

MTBF: >50,000 hours continuous operation

Approvals

CE (EMC and machinery directives)

IQ Throttling Butterfly Valves

MODEL NUMBER	NOM. ID	FLANGE TYPE	A	B	C	D	WEIGHT
TBV-IQA-100-NW-25	1 (25)	NW-25	2.25 (57.1)	2.75 (69.8)	8.34 (211.8)	0.87 (22.1)	5.5 (2.5)
TBV-IQA-150-NW-40	1.5 (38)	NW-40	2.25 (57.1)	2.75 (69.8)	8.34 (211.8)	1.39 (35.31)	5.3 (2.4)
TBV-IQA-200-NW-50	2 (50)	NW-50	2.00 (50.8)	3.36 (85.3)	8.65 (219.7)	1.98 (50.3)	5.5 (2.5)
TBV-IQA-250-ISO-63	2.5 (63)	ISO-63	1.00 (25.4)	5.12 (130.0)	9.10 (231.1)	2.44 (62.0)	7.5 (3.4)
TBV-IQA-300-ISO-80	3 (76)	ISO-80	1.00 (25.4)	5.71 (145.0)	9.42 (239.3)	2.94 (74.7)	8.8 (4.0)
TBV-IQA-400-ISO-100	4 (100)	ISO-100	1.00 (25.4)	6.50 (165.1)	9.85 (250.2)	3.85 (97.8)	9.5 (4.3)
TBV-IQA-600-ISO-160	6 (150)	ISO-160	1.62 (41.1)	8.90 (226.1)	10.4 (264.2)	5.87 (149.1)	21.8 (9.9)
TBV-IQA-800-ISO-200	8 (200)	ISO-200	1.62 (41.1)	11.2 (284.5)	12.4 (315.0)	7.87 (199.9)	28.5 (12.9)
TBV-IQA-1000-ISO-250	10 (250)	ISO-250	1.62 (41.1)	13.2 (335.3)	13.3 (337.8)	9.88 (250.9)	38.0 (17.3)
TBV-IQA-1200-ISO-320	12 (300)	ISO-320	1.62 (41.1)	16.73 (424.9)	15.35 (389.9)	12.31 (312.7)	51 (23.2)

Note: IQA can be replaced with IQD, IQD2, IQE, and IQR

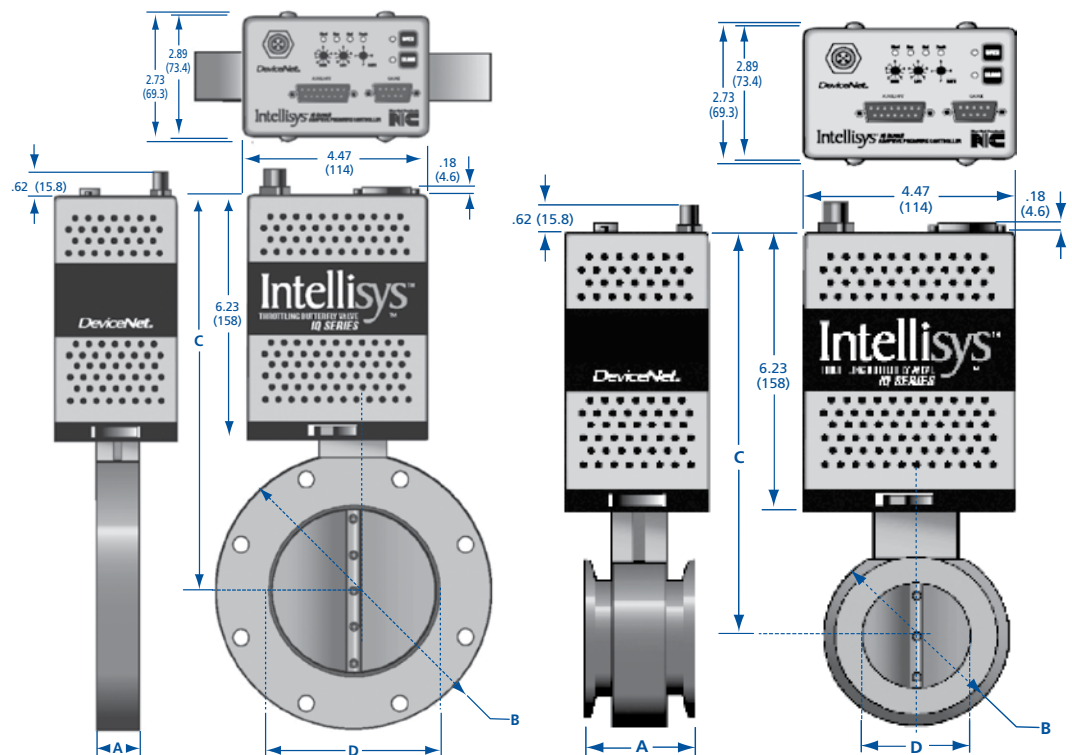

All dimensions are in inches (mm) & weights are in pounds (kg), unless otherwise noted.

Seal Material Options

SEAL MATERIAL	CODE
Viton	Default (no code)
Kalrez 4079	-K79
Kalrez 8085	-K85
Kalrez 8575	-K75
Kalrez 9100	-K91
Chemraz E38	-C38
Dupra 192	-D19
Perlast G74P	-PP7

Example: TBV-IQD-400-ISO-100-C38
 IQD TBV with 4 inch bore, ISO 100 flanges and Chemraz E38 O-rings.

Downstream Pressure Control Throttling Butterfly Valves



IQ+ Throttling Butterfly Valves

Nor-Cal's new IQ+ controller is available on the complete line of regular and sealing Throttling Butterfly Valves (TBV and TBVS) turning what is very good performance into best-in-class process control. The IQ+ controller is an on-valve integral control & drive unit that is fully RoHS compliant with 100% lead-free circuit board content. User interfaces include an ODVA certified DeviceNet protocol and physical layer, as well as standard RS-232 communications. Gauge power capabilities have been upgraded to a full 1500 mA at

+/- 15 VDC in order to power two heated CDG's directly from the IQ+ unit. In addition, a battery backup feature is available that can be used to bring the valve to a fail-closed or fail-open safe position in the event of system power loss. Last, the IQ+ adaptive pressure control algorithm has been significantly improved to better deal with difficult control situations, in particular at conditions that typically occur at low pressures and low flows.

For larger system pressure control requiring multiple pumps and forelines, such as

on flat panel, industrial coating or photovoltaic tools, it is easily possible to gang up to ten valves together. Multi-valve Master/Slave system control like this is facilitated via the Nor-Cal-Net intervalve communications system. One IQ+ operated valve serves as the master with communications to the host tool, gauge input and has direct command over the control position of the remaining slave valves. The IQ+ controlled butterfly valves are the right answer to any new or challenging pressure control application.

MODEL NUMBER	NOM. ID	FLANGE TYPE	A	B	C	D	WEIGHT
TBV-QPD-NW-25	1 (25)	NW-25	2.25 (57.1)	2.75 (69.8)	8.34 (211.8)	0.87 (22.1)	5.5 (2.5)
TBV-QPD-NW-40	1.5 (38)	NW-40	2.25 (57.1)	2.75 (69.8)	8.34 (211.8)	1.39 (35.3)	5.3 (2.4)
TBV-QPD-NW-50	2 (50)	NW-50	2.00 (50.8)	3.36 (85.3)	8.65 (219.7)	1.98 (50.3)	5.5 (2.5)
TBV-QPD-ISO-63	2.5 (63)	ISO-63	1.00 (25.4)	5.12 (130.0)	9.10 (231.1)	2.44 (62.0)	7.5 (3.4)
TBV-QPD-ISO-80	3 (76)	ISO-80	1.00 (25.4)	5.71 (145.0)	9.42 (239.3)	2.94 (74.7)	8.8 (4.0)
TBV-QPD-ISO-100	4 (100)	ISO-100	1.00 (25.4)	6.50 (165.1)	9.85 (250.2)	3.85 (97.8)	9.5 (4.3)
TBV-QPD-ISO-160	6 (150)	ISO-160	1.62 (41.1)	8.90 (226.1)	10.4 (264.2)	5.87 (149.1)	21.8 (9.9)
TBV-QPD-ISO-200	8 (200)	ISO-200	1.62 (41.1)	11.2 (284.5)	12.4 (315.0)	7.87 (199.9)	28.5 (12.9)
TBV-QPD-ISO-250	10 (250)	ISO-250	1.62 (41.1)	13.2 (335.3)	13.3 (337.8)	9.88 (250.9)	38.0 (17.3)
TBV-QPD-ISO-320	12 (300)	ISO-320	1.62 (41.1)	16.73 (424.9)	15.35 (389.9)	12.31 (312.7)	51 (23.2)

Note: QPD can be replaced with QPDB, QPDG and QPDBG

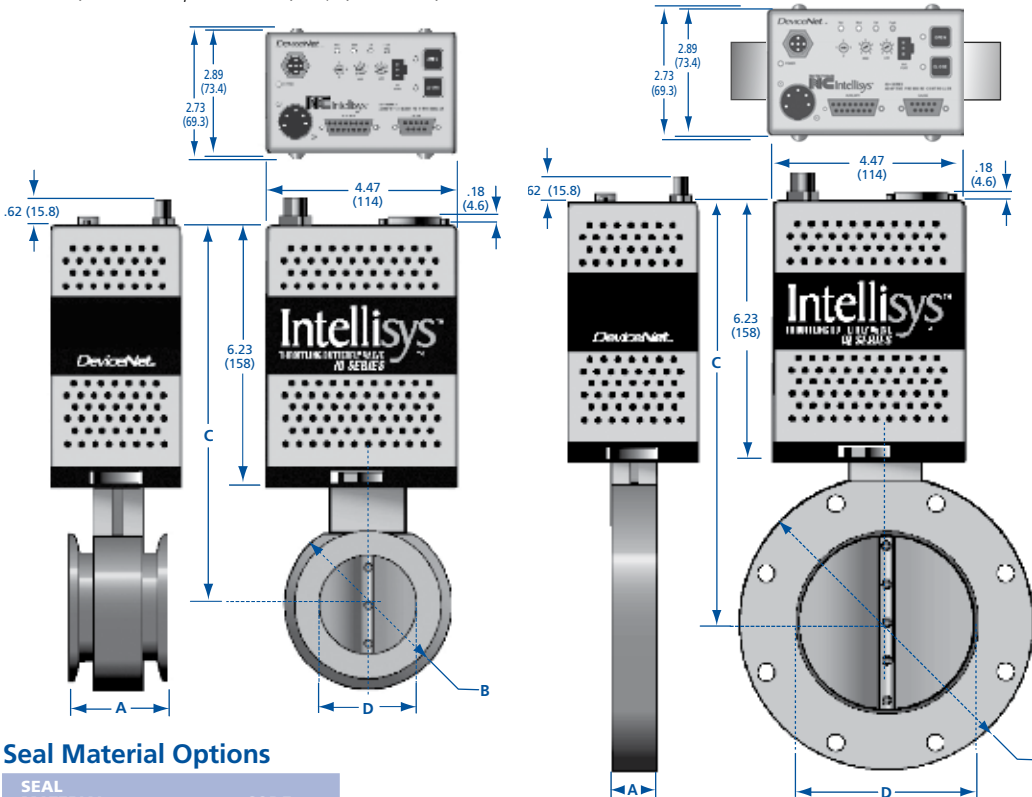

Seal Material Options

SEAL MATERIAL	CODE
Viton	Default (no code)
Kalrez 4079	-K79
Kalrez 8085	-K85
Kalrez 8575	-K75
Kalrez 9100	-K91
Chemraz E38	-C38
Dupra 192	-D19
Perlast G74P	-PP7

Example: **TBV-QPDBG-400-ISO-100-C38**
 IQ+ TBV with DeviceNet, battery backup, gauge power, 4 inch bore, ISO 100 flanges and Chemraz E38 O-rings.

SPECIFICATIONS

General

Controller Options:

- QPD:** DeviceNet / RS232 interface
 - QPDB:** DeviceNet / RS232 interface, with battery back-up
 - QPDG:** DeviceNet / RS232 interface, with gauge power
 - QPDBG:** DeviceNet / RS232 interface, with battery back-up and gauge power
- Contact the factory for other interfaces such as Analog, TTL, RS-485 and Ethernet.

Valve position: Visual indicator

Construction

Wetted materials: 316 stainless steel, seal material (see below)

Seals: Viton standard. Kalrez, Chemraz, Perlast and other materials available on request.

Operation

Power input: +24 VDC

Differential pressure: 1.1 bar maximum across the valve plate

Forced heating capabilities: Valves may be heated up to 150°C with optional external heaters.

Process gas temperature capabilities:

For process gas temperatures in excess of 100°C, please consult with Nor-Cal Intellisys technical support for proper selection of seal materials and other design considerations.

Ambient operating conditions:

0 - 60°C @ 0 - 95% humidity

Leak rate: 1 x 10⁻⁹ mbar-liter/sec He

Inherent performance

Open to close speed: 125 msec

Control resolution: 0.4 arc second

Maximum torque:

1" - 4": 280 in-oz

6" - 10": 700 in-oz

Pressure Control Performance

(when used with an Intellisys controller)

Algorithm: Improved for better stability and faster transitions

Accuracy: The greater of 5 mV or 0.25% of reading

Repeatability: Within 2.5mV or 0.12% of reading

Control range: 0.5% - 100% of the vacuum gauge range

Reliability

(99% confidence level, in clean environment)

O-ring cycle life: 5 million open-close cycles

MTBF: >50,000 hrs. continuous

Approvals

RoHS compliant

ODVA certified DeviceNet

CE (EMC and machinery directives)

All dimensions are in inches (mm) & weights are in pounds (kg), unless otherwise noted.



SPECIFICATIONS

General

Controller Options:

- QP:** RS232 interface
- QPA:** Analog/TTL/RS232 interface
- QPD:** DeviceNet/RS232 interface
- QPM:** EtherCAT interface
- QPR:** RS485 Interface
- QPS:** Slave controller (used for master/slave systems)

Valve position: Visual indicator

Construction

Body materials: 6061 Aluminum, hard anodized aluminum or 316 stainless steel,
Seals: Viton standard. Kalrez, Chemraz, Perlast and other materials available on request.

Operation

Power input: +24 VDC

Differential pressure: 1.2 bar maximum across the valve plate

Valve bakeout capabilities: Valves may be heated up to 150°C with optional external heaters.

Process gas temperature capabilities:

For process gas temperatures in excess of 100°C, please consult with Nor-Cal Intellisys technical support for proper design considerations.

Ambient operating conditions:

0-45°C @ 0-95% humidity

Shaft Leak rate: 1×10^{-9} mbarl/sec He (SS, AL)
 1×10^{-6} mbarl/sec He (HA)

Plate Leak rate: 1×10^{-8} mbarl/sec He (SS, AL)
 1×10^{-5} mbarl/sec He (HA)

Inherent performance

Open to close speed: 0.5–0.8 seconds

Control resolution: 0.5 arc second

Maximum torque: 2100 in-oz

Pressure Control Performance

Accuracy: The greater of 5 mV or 0.25% of reading

Repeatability: Within 2.5mV or 0.12% of reading

Control range: 0.5% - 100% of the vacuum gauge range

Reliability

(99% confidence level, in clean environment)

MTBF: >10,000 hrs. continuous

Approvals

CE (EMC and machinery directives)

Intellisys™ Combination Butterfly Valve with Maximum Dynamic Range

Nor-Cal has upgraded its sealing butterfly valve technology to provide a broader and more robust product line. Available in either stainless steel or aluminum, the STBV-product is a dual function valve capable of acting both as foreline isolation- and down-stream pressure control valve. The isolation function is rated up to 1×10^{-9} mbar · l / sec depending on the choice of seal and body material, and is actuated through a dual cam self-locking linkage arrangement. The new valve ranges in sizes from 1 ½ to 4 inch (38-100mm) nominal ID's.

The dynamic range, or controllable conductance, of these valves spans from 0.01 liters/sec at closed for the 40mm size up to 600 liters/sec using the 100mm size valve in the full open position. When combined with the Intellisys™ on-board IQ+ controller, the STBV valves can be used to control chamber pressures up to 1 bar and beyond, even with very low gas flow rates. The ultra-fine motor resolution of the IQ+ controller enables extremely precise valve plate movement resulting in very smooth and stable system pressures.

Process by-product mitigation is accomplished by heating the valve body, either by use of heater jackets or integral cartridge heaters. The STBV valves can be baked out to 120°C as long as precautions are taken to ensure the IQ+ controller does not exceed 45°C.

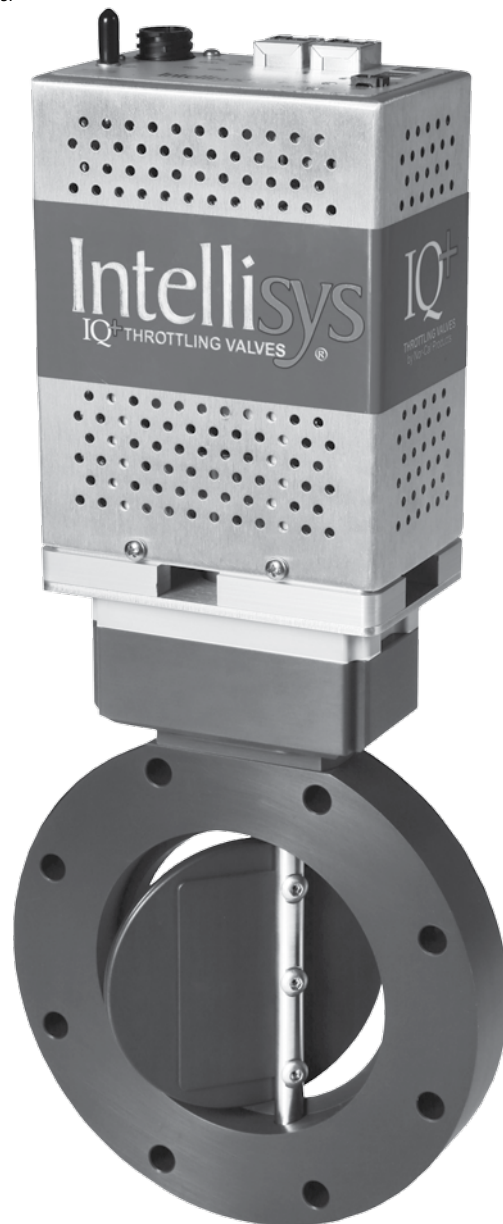

Seal Material Options

SEAL MATERIAL	CODE
Viton	Default (no code)
Kalrez 8085	-K85
Kalrez 8575	-K75
Kalrez 9100	-K91
Chemraz E38	-C38
Dupra 192	-D19
Perlast G74P	-PP7

Flapper O-ring Sizes

FLANGE SIZE	CODE
NW-40	OR-2-213
NW-50	OR-2-223
ISO-63	OR-2-228
ISO-80	OR-2-232
ISO-100	OR-2-237

Downstream Pressure Control

Sealing Throttling Butterfly Valves

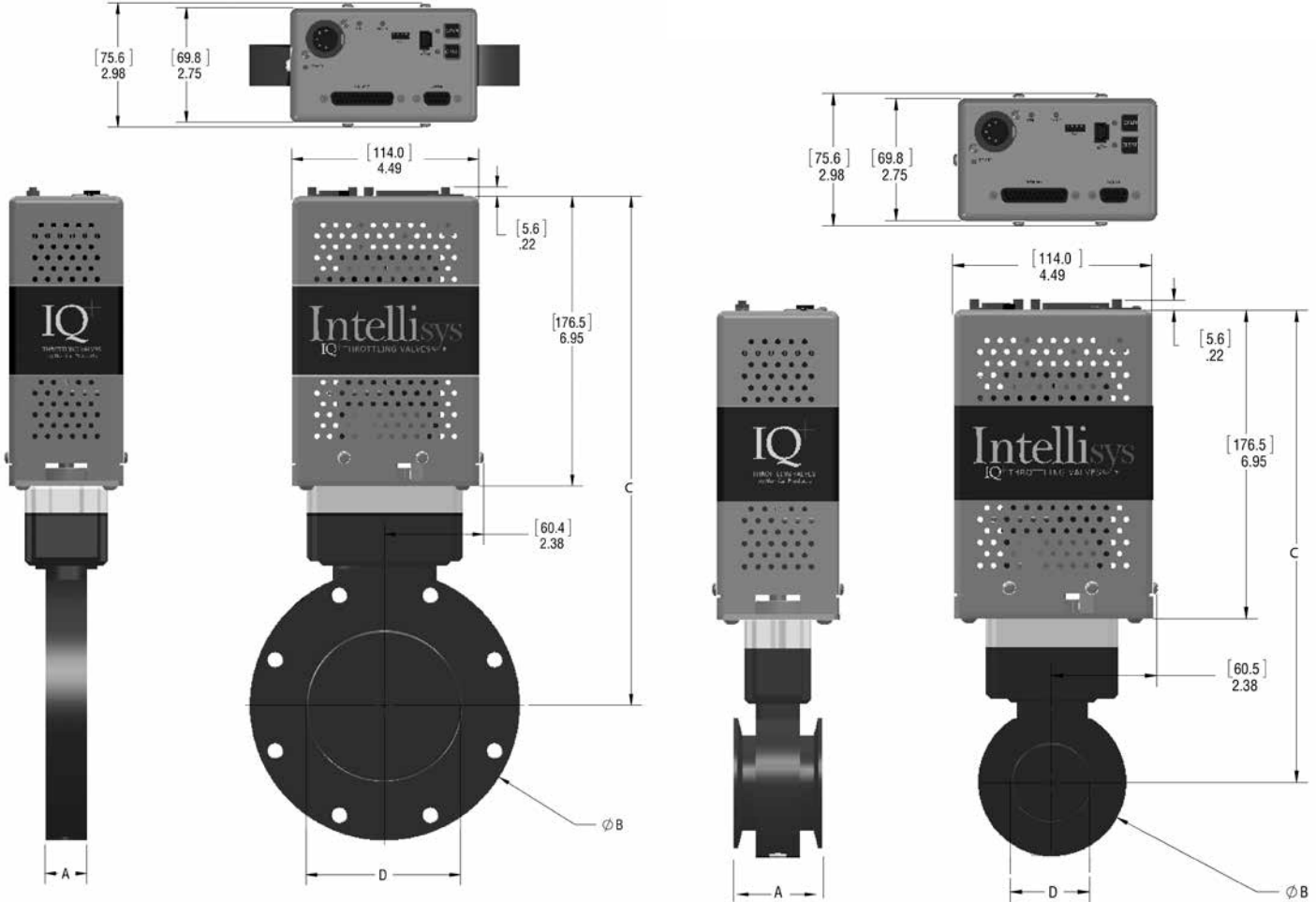

MODEL NUMBER	NOM. ID	FLANGE TYPE	A	B	C	D	WEIGHT (AL & HA)	WEIGHT (SS)
STBV-QPA-NW-40-xx	1.5	NW-40	2.25 (57.2)	2.75 (69.9)	10.33 (262.4)	1.21 (30.7)	6.7 (3.0)	7.7 (3.5)
STBV-QPA-NW-50-xx	2	NW-50	2.00 (50.8)	3.36 (85.3)	10.64 (270.3)	1.77 (45.0)	6.9 (3.1)	8.3 (3.8)
STBV-QPA-ISO-63-xx	2.5	ISO-63	1.00 (25.4)	5.12 (130.0)	11.44 (290.6)	2.49 (63.2)	8.0 (3.6)	10.8 (4.9)
STBV-QPA-ISO-80-xx	3	ISO-80	1.00 (25.4)	5.71 (145.0)	11.77 (299.0)	2.95 (74.9)	8.3 (3.8)	11.6 (5.3)
STBV-QPA-ISO-100-xx	4	ISO-100	1.00 (25.4)	6.50 (165.0)	12.21 (310.1)	3.62 (91.9)	9.3 (4.2)	13.0 (5.9)

Note: QPA can be replaced with QP, QPD, QPM, QPR or QPS

Note: "xx" designates the body material, AL for aluminum, HA for hard anodized aluminum and SS for stainless steel

Example: STBV-QPDBG-ISO-100-C38

IQ+ STBV with DeviceNet, battery backup, gauge power, 4 inch bore, ISO 100 flanges and Chemraz E38 O-rings.

All dimensions are in inches (mm) & weights are in pounds (kg), unless otherwise noted.

Downstream Pressure Control

Throttle Valve Heaters



Throttle Valve Heaters

Many semiconductor processes are carried out in vacuum chambers with internal temperatures of several hundred degrees Celsius. Process by-products exit the chamber in vapor phase, but sublimate in the foreline and vacuum pump exhaust when gas temperatures drop sufficiently for them to form solids. The resultant buildup can increase wafer defects from particle backstreaming, reduce throughput of vacuum lines, impede the function of throttle valves and isolation valves, damage some dry pumps and reduce the efficiency of the scrubber. This buildup can be reduced or eliminated by heating vacuum lines and associated components from the chamber to the scrubber, or by using a combination of heaters and foreline traps, which collect the by-products preventing them from continuing downstream.

Heater jackets with a UL recognized electronic thermostat for fixed set-point

applications is available for temperatures up to 150°C. For fully adjustable temperature set-points up to 200 °C, a UR/CE certified heater with a Type K thermocouple and PID controller can provide precise temperature control. Standard heaters cover the entire valve body, and in the case of butterfly valves also the mating flanges. As such, heaters for NW-flanged TBV's are provided with special aluminum clamps.

Standard ½ inch (12.7mm) insulation add-on heaters are available for all Throttling Butterfly and SoftShut Gate Valves. These can be purchased and installed separately provided that the valve is fitted with the proper high temperature seals and other thermally compatible components. Heaters for Throttling Pendulum Valves are integral to the valve, and must be ordered together. Field retrofit of a heater on to a TPV is not possible. Special heater solutions or higher temperature control for all valves may be available. Call for details.



Heater Jacket Part Number and Ordering Information

Please use the following part numbering tree to specify the heater jacket to fit your throttling butterfly or SoftShut valve. **Note:** All part number combinations may not be valid or available. Contact Nor-Cal Products for the latest pricing, availability and other options.

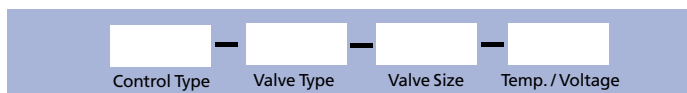

Control Type

CONTROL TYPE	CODE
PID control*	HC
Electronic thermostat	HTE

* Requires separate PID controller. (See controllers Section 6.)

Valve Type

VALVE TYPE	CODE
Throttling butterfly	TBV
Sealing throttling butterfly	TBVS
Throttling SoftShut - ISO	TSSI
Throttling SoftShut - CF	TSSC

Valve Size

VALVE SIZE	CODE
1.00*	100
1.50*	150
2.00*	200
2.50	250
3.00	300
4.00	400
6.00	600
8.00	800
10.00	1000

* Includes two special NW clamps

Temperature/Voltage

TEMPERATURE & VOLTAGE	CODE
HC type, 120 VAC	201
HC Type, 208 VAC	202
HTE type, 90°C, 120 VAC	091
HTE type, 90°C, 208 VAC	092
HTE type, 120°C, 120 VAC	121
HTE type, 120°C, 208 VAC	122
HTE type, 150°C, 120 VAC	151
HTE type, 150°C, 208 VAC	152

Example 1: **HC-TBV-250-201** PID controlled jacket for 2.5 inch ID TBV. 120 VAC.

Example 2: **HTE-TSSC-600-122** Electronic thermostat controlled jacket for 6 inch ID, CF flanged TSS. 120 °C and 208 VAC operation.

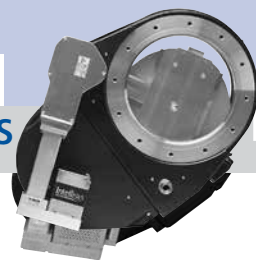

Unmatched Pressure Control Performance and Low Particle Generation

Nor-Cal's line of Intellisys pendulum valves provides equipment manufacturers with unmatched pressure control performance and low particle generation. Other pendulum valves use one actuation method to move the gate and another method to seal, creating an "out of control" area near the closed position. To compensate for this, system designers often add secondary bypass lines with costly throttling butterfly valves for high pressure, high flow regimes, such as NF_3 cleans. Intellisys pendulum valves utilize the same exclusive closed loop motor technology as other Nor-Cal control valves, but also feature a patented Penduroll actuator mechanism to move the sealing gate rapidly across the valve bore and transition to the axial direction. The result is precise pressure control over the entire valve stroke, most notably near the closed position. The Intellisys control system is the only choice for demanding 300mm Etch and CVD applications which require fast, accurate pressure control across the entire range of critical process flows and chamber pressures.

The Intellisys closed loop motor control monitors and controls the exact position of the valve's gate mechanism. When combined with an Intellisys adaptive pressure controller, the pendulum valves provide up to 160 million steps of positional resolution to position the gate exactly where it needs to be to control pressure or to seal. In addition, the Nor-Cal control system's speed of actuation is unequalled in providing optimal transient response, pressure set-point stability and overall process improvement. The APC's adaptive algorithm outperforms "learn modes" by optimizing phase and gain settings in real time during varying chamber pressure and flow conditions.

In-situ serviceability of the valve is made possible through the incorporation of a removable bonnet cover. The entire gate assembly and sealing O-ring can be accessed without removing the valve from the system, making regular inspections, cleanings and O-ring replacements quick and easy.

Nor-Cal Products also offers pneumatically actuated isolation pendulum valves that contain the same patented Penduroll mechanism that is found in the throttling valves. For more information about these valves, please refer to the Isolation Valves section of this catalog.

Features and Benefits

- Space saving, low cost design
- Low particle generation
- High reliability
- Easy maintenance, split body allows O-ring replacement without removing valve from system
- Body can be heated up to 150°C with optional heater jackets
- Available in ISO and JIS flange styles

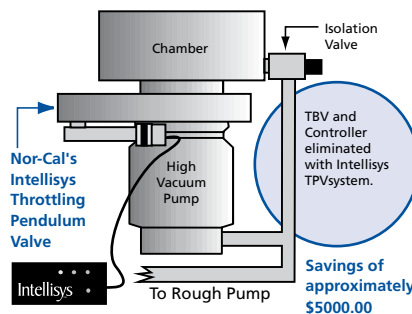
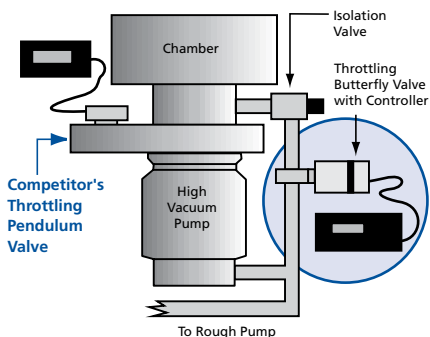

Downstream Pressure Control Throttling Pendulum Valves

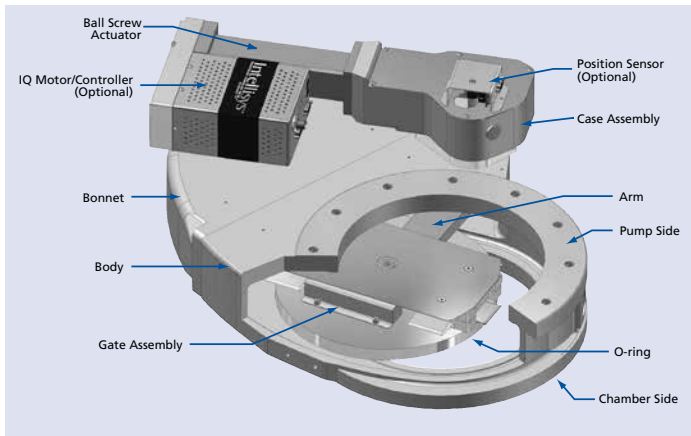
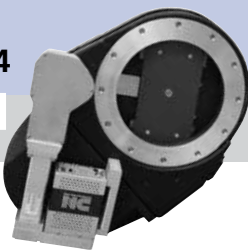

TPV Part Number and Ordering Information

Please use the following part numbering tree to add the appropriate options for a TPV to fit your application.

Note: All part number combinations may not be valid. Contact Nor-Cal Products for the latest pricing, availability and other options.

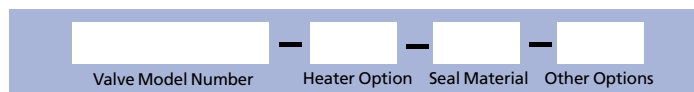

Heater Options

HEATER OPTIONS	OPERATION	CODE
None		<i>Leave blank</i>
90°C thermostat	120 VAC	HT091
120°C thermostat	120 VAC	HT121
150°C thermostat	120 VAC	HT151
90°C thermostat	208 VAC	HT092
120°C thermostat	208 VAC	HT122
150°C thermostat	208 VAC	HT152

Seal Material Options

SEAL MATERIAL	CODE
Viton	<i>Leave blank</i>
Kalrez 4079	-K79
Kalrez 8085	-K85
Kalrez 8575	-K75
Kalrez 9100	-K91
Chemraz E38	-C38
Dupra 192	-D19
Perlast G74P	-PP7

Other Options

OTHER OPTIONS	CODE
Motor actuator position R* (default)	<i>Leave blank</i>
Motor actuator position T*	T
Pump-out port (NW-16 size on DN160 and DN200 NW-40 size on DN250, DN320 and DN35)	U
Open / closed position indicators (Optical with indicating LEDs)	W
Mirror image body configuration	Z

*See dimension diagram on facing page

Example 1: TPV-800-ISO-200-MB-HT122-K79-T

TPV with 8 inch ISO flanges, bright dipped aluminum, heated to 120°C with thermostat control, 208 VAC operation, Kalrez 4079 compound O-ring material and motor actuator in T position

Example 2: TPV-QPDB-ISO-250-C38

IQ+ TPV with DeviceNet and battery backup, 10 inch ISO flanges and E38 Chemraz O-ring material.

Body Materials Available

Standard TPV bodies are cast aluminum that have been either bright dipped or hard anodized. Some sizes are machined and either bright dipped or hard anodized. The model number denotes the body material and surface treatment used for each size. **Note:** Some sizes are not available in both machined and cast bodies.

BODY MATERIAL	CODE
Cast bright dipped aluminum	<i>Default</i>
Cast Type III hard anodize	HA
Machined bright dipped aluminum	MB
Machined Type III hard anodize	HM

All dimensions are in inches (mm) & weights are in pounds (kg), unless otherwise noted.

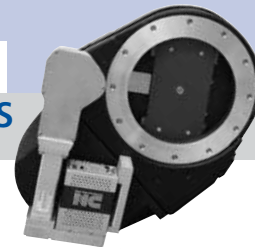

Throttling Pendulum Valves

MODEL NUMBER	NOM. ID	FLANGE TYPE	A	B	C	D	E	F	N	M	L	WEIGHT
TPVP-600-ISO-160	6	ISO-160	3.15 (80.0)	3.78 (96.0)	15.9 (403)	12.2 (310)	5.31 (135)	8.50 (216)	8	M10	(10)	40 (18.0)
TPVP-600-ISO-160-HA	6	ISO-160	3.15 (80.0)	3.78 (96.0)	15.9 (403)	12.2 (310)	5.31 (135)	8.50 (216)	8	M10	(10)	40 (18.0)
TPVP-800-ISO-200-MB	8	ISO-200	3.46 (87.9)	3.78 (96.0)	19.9 (506)	14.4 (266)	6.50 (165)	9.29 (236)	12	M10	(10)	49 (22.2)
TPVP-800-ISO-200-HM	8	ISO-200	3.46 (87.9)	3.78 (96.0)	19.9 (506)	14.4 (266)	6.50 (165)	9.29 (236)	12	M10	(10)	49 (22.2)
TPVP-1000-ISO-250	10	ISO-250	3.94 (100)	3.78 (96.0)	23.8 (605)	16.6 (422)	8.46 (215)	9.49 (241)	12	M10	(10)	62 (28.1)
TPVP-1000-ISO-250-HA	10	ISO-250	3.94 (100)	3.78 (96.0)	23.8 (605)	16.6 (422)	8.46 (215)	9.49 (241)	12	M10	(10)	62 (28.1)
TPVP-1200-ISO-320	12	ISO-320	4.72 (120)	4.06 (103)	30.2 (767)	22.0 (559)	10.6 (269)	12.8 (325)	12	M12	(18)	123 (55.8)
TPVP-1200-ISO-320-HA	12	ISO-320	4.72 (120)	4.06 (103)	30.2 (767)	22.0 (559)	10.6 (269)	12.8 (325)	12	M12	(18)	123 (55.8)
TPVP-600-JIS-150	6	JIS-150	3.15 (80.0)	3.78 (96.0)	15.9 (403)	12.2 (310)	5.31 (135)	8.50 (216)	8	M10	(10)	40 (18.0)
TPVP-600-JIS-150-HA	6	JIS-150	3.15 (80.0)	3.78 (96.0)	15.9 (403)	12.2 (310)	5.31 (135)	8.50 (216)	8	M10	(10)	40 (18.0)
TPVP-800-JIS-200-MB	8	JIS-200	3.46 (87.9)	3.78 (96.0)	19.9 (506)	14.4 (266)	6.50 (165)	9.29 (236)	8	M12	(12)	49 (22.2)
TPVP-800-JIS-200-HM	6	JIS-200	3.46 (87.9)	3.78 (96.0)	19.9 (506)	14.4 (266)	6.50 (165)	9.29S (236)	8	M12	(12)	49 (22.2)
TPVP-1000-JIS-250	10	JIS-250	3.94 (100)	3.78 (96.0)	23.8 (605)	16.6 (422)	8.46 (215)	9.49 (241)	12	M12	(12)	62 (28.1)
TPVP-1000-JIS-250-HA	10	JIS-250	3.94 (100)	3.78 (96.0)	23.8 (605)	16.6 (422)	8.46 (215)	9.49 (241)	12	M12	(12)	62 (28.1)
TPVP-1200-JIS-300	12	JIS-300	4.72 (120)	4.06 (103)	30.2 (767)	22.0 (559)	10.6 (269)	12.8 (325)	12	M12	(18)	123 (55.8)
TPVP-1200-JIS-300-HA	12	JIS-300	4.72 (120)	4.06 (103)	30.2 (767)	22.0 (559)	10.6 (269)	12.8 (325)	12	M12	(18)	123 (55.8)
TPVP-1400-JIS-350	4	JIS-350	4.92 (125)	4.06 (103)	32.3 (820)	22.0 (559)	12.2 (310)	12.8 (325)	12	M12	(18)	143 (64.9)
TPVP-1400-JIS-350-HA	14	JIS-350	4.92 (125)	4.06 (103)	32.3 (820)	22.0 (559)	12.2 (310)	12.8 (325)	12	M12	(18)	143 (64.9)

Note: N=Number bolt holes M=Thread bolt diameter L=Thread depth

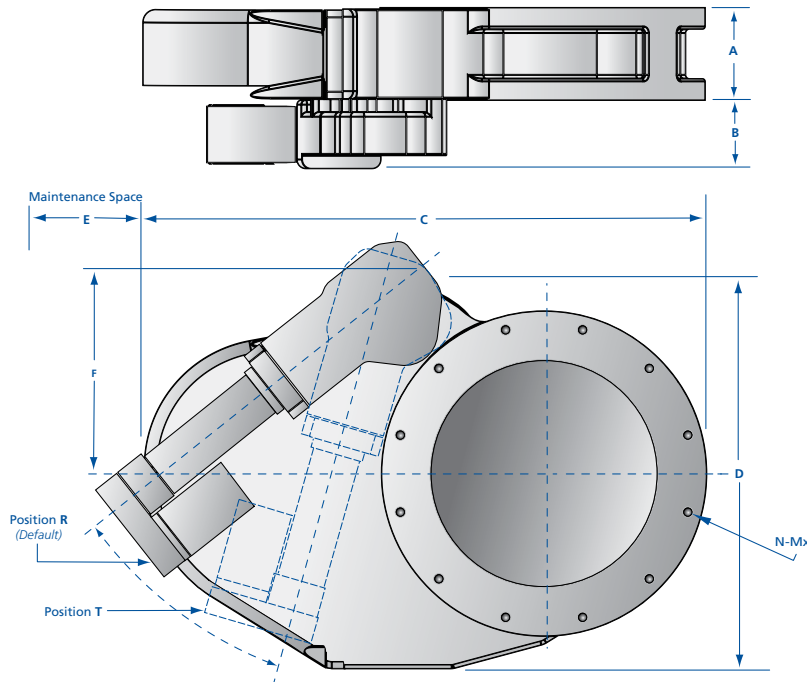

SPECIFICATIONS

General

Compatible controllers: 800-series APC buried box controllers

Construction

Wetted materials

Body: Cast aluminum A356.0 (machined billet aluminum 6061-T6 in 8" size)

Valve plate: Aluminum 6061-T6

Other parts: A6061, A7075, SS304, SS316,

Inconel X-750 and Viton

Seals: Viton standard, Kalrez, Chemraz,

Perlast and other materials available

Body and plate surface treatment: Bare aluminum standard, hard Type III anodizing optional

Operation

Motor power input: Supplied by BQC controller. Refer to APC section.

Differential pressure:

With valve fully sealed: 1.1 bar maximum across the valve plate

While opening the valve

27 mbar (DN160 and DN200)

32 mbar (DN250)

39 mbar (DN320 & DN350)

Operating pressure: 3.8×10^{-8} to 1 bar

Heating or bakeout capabilities:

Body: 150°C maximum with optional heater kits

Actuator: 60°C maximum

Ambient operating conditions:

0 - 60°C @ 0 - 95% humidity, noncondensing

Leak rate: 1×10^{-9} mbar-liter/sec He with Viton seals across seat and to atmosphere

(1×10^{-6} mbar-liter/sec He for hard anodized body or gate)

Derated with some perfluoro-elastomers

Inherent performance

Maximum speed: Open to closed in 2 to 5 seconds, depending on size

Control resolution: 16 to 40 million steps, open to closed, depending on size

Pressure control performance

(when used with an Intellisys controller)

Accuracy: The greater of 5 mV or 0.25% of reading

Repeatability: Within 2.5 mV or 0.12% of reading

Control range: 0.5% - 100% of the vacuum gauge range

Reliability

(99% confidence level, in clean environment)

O-ring cycle life: 1 million cycles open to control closed. 200K cycles open to fully closed.

MTBF: >10,000 hrs. continuous operation

Approvals

CE (EMC and machinery directives)

Options

Body & seal material, drive & heater (see options page this section)

JIS Flange O-Rings

SIZE	O-RINGS
150	OR-JIS-150
200	OR-JIS-200
250	OR-JIS-250
320	OR-JIS-320
350	OR-JIS-350

Downstream Pressure Control Throttling Pendulum Valves

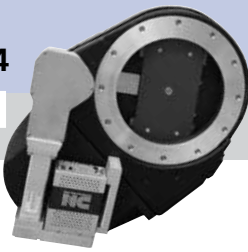

IQ Throttling Pendulum Valves

MODEL NUMBER	NOM. ID	FLANGE TYPE	A	B	C	D	E	F	N	M	L	WEIGHT
TPV-IQA-600-ISO-160	6	ISO-160	3.15 (80.0)	3.78 (96.0)	15.9 (403)	12.2 (310)	5.31 (135)	8.50 (216)	8	M10	(10)	40 (18.0)
TPV-IQA-600-ISO-160-HA	6	ISO-160	3.15 (80.0)	3.78 (96.0)	15.9 (403)	12.2 (310)	5.31 (135)	8.50 (216)	8	M10	(10)	40 (18.0)
TPV-IQA-800-ISO-200-MB	8	ISO-200	3.46 (87.9)	3.78 (96.0)	19.9 (506)	14.4 (266)	6.50 (165)	9.29 (236)	12	M10	(10)	49 (22.2)
TPV-IQA-800-ISO-200-HM	8	ISO-200	3.46 (87.9)	3.78 (96.0)	19.9 (506)	14.4 (266)	6.50 (165)	9.29 (236)	12	M10	(10)	49 (22.2)
TPV-IQA-1000-ISO-250	10	ISO-250	3.94 (100)	3.78 (96.0)	23.8 (605)	16.6 (422)	8.46 (215)	9.49 (241)	12	M10	(10)	62 (28.1)
TPV-IQA-1000-ISO-250-HA	10	ISO-250	3.94 (100)	3.78 (96.0)	23.8 (605)	16.6 (422)	8.46 (215)	9.49 (241)	12	M10	(10)	62 (28.1)
TPV-IQA-1200-ISO-320	12	ISO-320	4.72 (120)	4.06 (103)	30.2 (767)	22.0 (559)	10.6 (269)	12.8 (325)	12	M12	(18)	123 (55.8)
TPV-IQA-1200-ISO-320-HA	12	ISO-320	4.72 (120)	4.06 (103)	30.2 (767)	22.0 (559)	10.6 (269)	12.8 (325)	12	M12	(18)	123 (55.8)
TPV-IQA-600-JIS-150	6	JIS-150	3.15 (80.0)	3.78 (96.0)	15.9 (403)	12.2 (310)	5.31 (135)	8.50 (216)	8	M10	(10)	40 (18.0)
TPV-IQA-600-JIS-150-HA	6	JIS-150	3.15 (80.0)	3.78 (96.0)	15.9 (403)	12.2 (310)	5.31 (135)	8.50 (216)	8	M10	(10)	40 (18.0)
TPV-IQA-800-JIS-200-MB	8	JIS-200	3.46 (87.9)	3.78 (96.0)	19.9 (506)	14.4 (266)	6.50 (165)	9.29 (236)	8	M12	(12)	49 (22.2)
TPV-IQA-800-JIS-200-HM	8	JIS-200	3.46 (87.9)	3.78 (96.0)	19.9 (506)	14.4 (266)	6.50 (165)	9.29 (236)	8	M12	(12)	49 (22.2)
TPV-IQA-1000-JIS-250	10	JIS-250	3.94 (100)	3.78 (96.0)	23.8 (605)	16.6 (422)	8.46 (215)	9.49 (241)	12	M12	(12)	62 (28.1)
TPV-IQA-1000-JIS-250-HA	10	JIS-250	3.94 (100)	3.78 (96.0)	23.8 (605)	16.6 (422)	8.46 (215)	9.49 (241)	12	M12	(12)	62 (28.1)
TPV-IQA-1200-JIS-300	12	JIS-300	4.72 (120)	4.06 (103)	30.2 (767)	22.0 (559)	10.6 (269)	12.8 (325)	12	M12	(18)	123 (55.8)
TPV-IQA-1200-JIS-300-HA	12	JIS-300	4.72 (120)	4.06 (103)	30.2 (767)	22.0 (559)	10.6 (269)	12.8 (325)	12	M12	(18)	123 (55.8)
TPV-IQA-1400-JIS-350	14	JIS-350	4.92 (125)	4.06 (103)	32.3 (820)	22.0 (559)	12.2 (310)	12.8 (325)	12	M12	(18)	143 (64.9)
TPV-IQA-1400-JIS-350-HA	14	JIS-350	4.92 (125)	4.06 (103)	32.3 (820)	22.0 (559)	12.2 (310)	12.8 (325)	12	M12	(18)	143 (64.9)

NOTE: IQA can be replaced with IQD, IQD2, IQE and IQR N=Number bolt holes M=Thread bolt diameter L=Thread depth

SPECIFICATIONS

General

Controller Options:

- IQA: Analog / TTL / RS232 interface
- IQD: DeviceNet / RS232 interface
- IQD2: DeviceNet / RS232 interface, no power via DN connector
- IQE: Ethernet / RS232 interface
- IQR: RS485 interface

Construction

Wetted materials:

- Body: Cast aluminum A356.0 (machined billet aluminum 6061-T6 in 8" size)
- Valve plate: Aluminum 6061-T6
- Other parts: A6061, A7075, SS304, SS316, Inconel X-750 and Viton
- Seals: Viton standard. Kalrez, Chemraz, Perlast and other materials available
- Body and plate surface treatment: Bare aluminum standard, hard Type III anodizing optional

Operation

- IQ controller power input: +24 VDC, +/- 10%
- Differential pressure: With valve fully sealed: 1.1 bar maximum cross the valve plate
While opening the valve: 27 mbar (DN160 & DN200); 32 mbar (DN250); 29 mbar (DN320 & DN350)
- Operating pressure: 3.8×10^{-8} to 1 bar
- Heating or bakeout capabilities: Body: 150°C maximum with optional heater kits
Actuator: 60°C maximum
- Ambient operating conditions: 0 - 45°C @ 0 - 95% humidity, non-condensing
- Leak rate: 1×10^{-9} mbar-liter sec⁻¹ He Viton seals across seat and to atmosphere (1×10^{-6} mbar-liter sec⁻¹ He for hard anodized body or gate). Derated with some perfluoro-elastomers.

Inherent performance

- Maximum speed: Open to closed in 2 to 5 seconds, depending on size
- Control resolution: 16 to 40 million steps, open to closed, depending on size

Pressure control performance

- (when used with an Intellisys controller)
- Accuracy: The greater of 5mV or 0.25% of reading
- Repeatability: Within 2.5mV or 0.12% of reading
- Control range: 0.5% - 100% of the vacuum gauge range

Reliability (99% confidence level, in clean environment)

- O-ring cycle life: 1 million cycles open to control closed. 200K cycles open to fully closed.
- MTBF: >10,000 hrs. continuous operation

Approvals

- CE (EMC and machinery directives)

Options

- Body & seal material, drive & heater (see options page this section)

All dimensions are in inches (mm) & weights are in pounds (kg), unless otherwise noted.

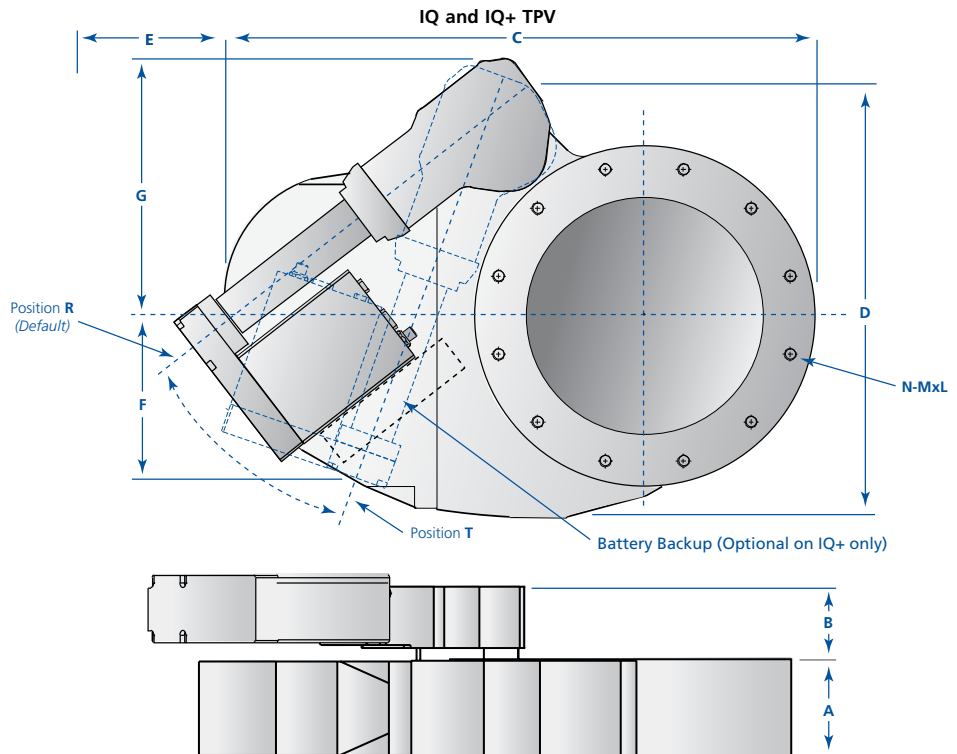

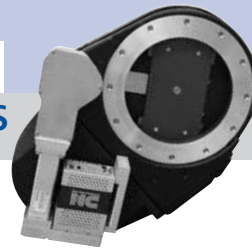

IQ+ Throttling Pendulum Valves



Nor-Cal's new IQ+ controller is available on the complete line of Throttling Pendulum Valves (TPV) turning what is very good performance into best-in-class

process control. The IQ+ controller is an on-valve integral control & drive unit that is fully RoHS compliant with 100% lead-free circuit board content. User interfaces include an ODVA certified DeviceNet protocol and physical layer, as well as standard RS-232 communications. Gauge power capabilities have been upgraded to a full 1500 mA at +/- 15 VDC in order to power two heated CDG's directly from the IQ+ unit. In addition, a battery back-up feature is available that can be used to bring the valve to a fail-closed or fail-open safe position in the event of system power loss. Last, the IQ+ adaptive pressure control algorithm has been significantly improved to better deal with difficult control situations, in particular at conditions that typically occur at low pressures and low flows.

For larger system pressure control requiring multiple pumps and forelines, such as on flat panel, industrial coating or photovoltaic tools, it is easily possible to gang up to ten valves together. Multi-valve Master/ Slave system control like this is facilitated via the Nor-Cal-Net inter-valve communications system. One IQ+ operated valve serves as the master with communications to the host tool, gauge input and has direct command over the control position of the remaining slave valves. The IQ+ controlled pendulum valves are the right answer to any new or challenging pressure control application.

SPECIFICATIONS

General

Controller Options:

- QPD:** DeviceNet / RS232 interface
 - QPDB:** DeviceNet / RS232 interface, with battery backup
 - QPDG:** DeviceNet / RS232 interface, with gauge power
 - QPDBG:** DeviceNet / RS232 interface, with battery backup and gauge power
- Contact the factory for other interfaces, such as Analog, TTL, RS-485 and Ethernet.

Construction

Wetted materials

- Body:** Cast aluminum A356.0 (machined billet aluminum 6061-T6 in 8 inch size)
- Valve plate:** Aluminum 6061-T6
- Other parts:** A6061, A7075, SS304, SS316, Inconel X-750 and Viton
- Seals:** Viton standard. Kalrez, Chemraz, Perlast and other materials available
- Body and plate surface treatment:** Bare aluminum standard, hard Type III anodizing optional

Operation

- Power input:** +24 VDC
- Differential pressure:** With valve fully sealed: 1.1 bar maximum across the valve plate
- While opening the valve:** 27 mbar (DN160 and DN200) 32 mbar (DN250) 39 mbar (DN320 & DN350)
- Operating pressure:** 3.8×10^{-8} to 1 bar
- Heating or bakeout capabilities:** Body: 150°C maximum with optional heater kits Actuator: 60°C maximum
- Ambient operating conditions:** 0 - 45°C @ 0 - 95% humidity, non-condensing
- Leak rate:** 1×10^{-9} mbar-liter/sec He with Viton seals across seat and to atmosphere (1×10^{-6} mbar-liter/sec He for hard anodized body or gate)
- Derated with some perfluoro-elastomers

Inherent performance

- Maximum speed:** Open to closed in 2 to 5 seconds, depending on size
- Control resolution:** 64 to 160 million steps, open to closed, depending on size

Pressure control performance

(when used with an Intellisys controller)

- Accuracy:** The greater of 5 mV or 0.25% of reading
- Repeatability:** Within 2.5 mV or 0.12% of reading
- Control range:** 0.5% - 100% of the vacuum gauge range

Reliability

(99% confidence level, in clean environment)

- O-ring cycle life:** 1 million cycles open to control closed. 200K cycles open to fully closed.
- MTBF:** >10,000 hrs. continuous operation

Approvals

- RoHS compliant
- ODVA certified DeviceNet
- CE (EMC and machinery directives)

Options

- Body & seal material, drive & heater (see options page this section)

MODEL NUMBER	NOM. ID	FLANGE TYPE	A	B	C	D	E	F	N	M	L	WEIGHT
TPV-QPD-ISO-160	6	ISO-160	3.15 (80.0)	3.78 (96.0)	15.9 (403)	12.2 (310)	5.31 (135)	8.50 (216)	8	M10	(10)	40 (18.0)
TPV-QPD-ISO-160-HA	6	ISO-160	3.15 (80.0)	3.78 (96.0)	15.9 (403)	12.2 (310)	5.31 (135)	8.50 (216)	8	M10	(10)	40 (18.0)
TPV-QPD-ISO-200-MB	8	ISO-200	3.46 (87.9)	3.78 (96.0)	19.9 (506)	14.4 (266)	6.50 (165)	9.29 (236)	12	M10	(10)	49 (22.2)
TPV-QPD-ISO-200-HM	8	ISO-200	3.46 (87.9)	3.78 (96.0)	19.9 (506)	14.4 (266)	6.50 (165)	9.29 (236)	12	M10	(10)	49 (22.2)
TPV-QPD-ISO-250	10	ISO-250	3.94 (100)	3.78 (96.0)	23.8 (605)	16.6 (422)	8.46 (215)	9.49 (241)	12	M10	(10)	62 (28.1)
TPV-QPD-ISO-250-HA	10	ISO-250	3.94 (100)	3.78 (96.0)	23.8 (605)	16.6 (422)	8.46 (215)	9.49 (241)	12	M10	(10)	62 (28.1)
TPV-QPD-ISO-320	12	ISO-320	4.72 (120)	4.06 (103)	30.2 (767)	22.0 (559)	10.6 (269)	12.8 (325)	12	M12	(18)	123 (55.8)
TPV-QPD-ISO-320-HA	12	ISO-320	4.72 (120)	4.06 (103)	30.2 (767)	22.0 (559)	10.6 (269)	12.8 (325)	12	M12	(18)	123 (55.8)
TPV-QPD-JFF-150	6	JIS-150	3.15 (80.0)	3.78 (96.0)	15.9 (403)	12.2 (310)	5.31 (135)	8.50 (216)	8	M10	(10)	40 (18.0)
TPV-QPD-JFF-150-HA	6	JIS-150	3.15 (80.0)	3.78 (96.0)	15.9 (403)	12.2 (310)	5.31 (135)	8.50 (216)	8	M10	(10)	40 (18.0)
TPV-QPD-JFF-200-MB	8	JIS-200	3.46 (87.9)	3.78 (96.0)	19.9 (506)	14.4 (266)	6.50 (165)	9.29 (236)	8	M12	(12)	49 (22.2)
TPV-QPD-JFF-200-HM	8	JIS-200	3.46 (87.9)	3.78 (96.0)	19.9 (506)	14.4 (266)	6.50 (165)	9.29 (236)	8	M12	(12)	49 (22.2)
TPV-QPD-JFF-250	10	JIS-250	3.94 (100)	3.78 (96.0)	23.8 (605)	16.6 (422)	8.46 (215)	9.49 (241)	12	M12	(12)	62 (28.1)
TPV-QPD-JFF-250-HA	10	JIS-250	3.94 (100)	3.78 (96.0)	23.8 (605)	16.6 (422)	8.46 (215)	9.49 (241)	12	M12	(12)	62 (28.1)
TPV-QPD-JFF-300	12	JIS-300	4.72 (120)	4.06 (103)	30.2 (767)	22.0 (559)	10.6 (269)	12.8 (325)	12	M12	(18)	123 (55.8)
TPV-QPD-JFF-300-HA	12	JIS-300	4.72 (120)	4.06 (103)	30.2 (767)	22.0 (559)	10.6 (269)	12.8 (325)	12	M12	(18)	123 (55.8)
TPV-QPD-JFF-350	14	JIS-350	4.92 (125)	4.06 (103)	32.3 (820)	22.0 (559)	12.2 (310)	12.8 (325)	12	M12	(18)	143 (64.9)
TPV-QPD-JFF-350-HA	14	JIS-350	4.92 (125)	4.06 (103)	32.3 (820)	22.0 (559)	12.2 (310)	12.8 (325)	12	M12	(18)	143 (64.9)

NOTE: QPD can be replaced with QPDB, QPDG and QPDBG N=Number bolt holes M=Thread bolt diameter L=Thread depth

JIS Flange O-Rings

SIZE	O-RINGS
150	OR-JIS-150
200	OR-JIS-200
250	OR-JIS-250
300	OR-JIS-300
350	OR-JIS-350





Downstream Pressure Control

Throttling SoftShut Gate Valves

The Stainless Steel Alternative to Aluminum Pendulum Valves

Throttling SoftShut gate valves offer the equipment manufacturer a stainless steel material alternative to the Nor-Cal line of aluminum pendulum valves, without compromising on pressure control performance and particle generation. Like the Intellisys pendulum valves, the TSS valves use one common actuation method to move the gate across the valve bore all the way to the sealed position. A "lock over center" feature means that all throttling SoftShut valves remain fully sealed even when power is removed. Furthermore, the design of the throttling gate mechanism permits pressure control over an expanded range. The result is precise

pressure control over the entire spectrum of flow rates and pressures thereby eliminating the need for bypass lines containing separate pressure control valves.

The Intellisys closed loop motor control monitors and controls the exact position of the valve's gate mechanism. When combined with an Intellisys adaptive pressure controller, the TSS gate valves provide over 6 million steps of positional resolution to position the gate exactly where it needs to be to control pressure or to seal. In addition, the Nor-Cal control system's speed of actuation is unequalled in providing optimal transient response,

pressure set-point stability and overall process improvement. The APC's adaptive algorithm outperforms "learn modes" by optimizing phase and gain settings in real time during varying chamber pressure and flow conditions.

In-situ serviceability of the valve is made possible through the incorporation of a removable rear plate cover. The entire gate assembly and sealing O-ring can be accessed without removing the valve from the system, making regular inspections, cleanings and O-ring replacements quick and easy.

Intellisys SoftShut valves offer the lowest particle generation

Isolation and throttling gate valves have historically received questionable ratings in the area of particulate generation. This is attributable to the relatively large number of moving parts of the gate slide- and actuation mechanism, and especially when those parts are in metal-to-metal contact with each other. Overcoming particle generation concerns was a paramount goal in the design effort of the SoftShut valve. In short, the number of moving parts and metal-to-metal surface contact were both minimized. And when moving parts had to be used, they were designed in either entirely out of the gas process stream or shielded from that stream as much as possible. The results of this design focus speak for themselves, as is evident in the adjacent chart. A SoftShut valve and an equivalent competitive gate valve of the same size were tested under identical circumstances, in which they were cycled open-to-closed continuously while a particle count was recorded every 10 cycles.

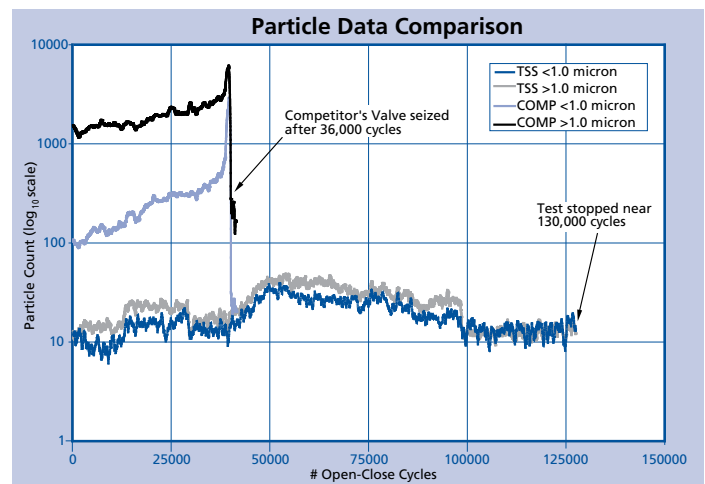

The particle measurement was taken in the volume upstream of the test valve in order to simulate what one might expect to find in the process chamber. As the data indicates, the competitive valve generated one to two orders of magnitude more particles throughout

the test and it failed completely after only 36,000 cycles. The SoftShut valve, on the other hand, showed a near constant particle generation trend until the test was stopped at a cycle count of 130,000.

TSS Part Number and Ordering Information

Please use the following part numbering tree to add the appropriate options for a TSS to fit your application.

Note: All part number combinations may not be valid. Contact Nor-Cal Products for the latest pricing, availability and other options.

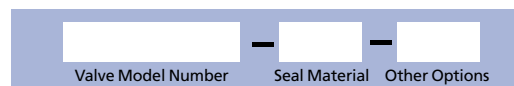

Seal Material Options

SEAL MATERIAL	CODE
Viton (Bonded)	Leave blank
Viton (O-ring)	-V
Kalrez 4079	-K79
Kalrez 8085	-K85
Kalrez 8575	-K75
Kalrez 9100	-K91
Chemraz E38	-C38
Dupra 192	-D19
Perlast G74P	-PP7

Other Options

OTHER OPTIONS	CODE
Motor actuator position R (default)	Leave blank
Motor actuator position T	T
Pumpout port (NW-16 on 5 through 8 inch size and NW-40 on 10 inch size)	U

Example: TSS-IQD2-600-ISO-160-V

6 inch TSS valve with IQD2 controller, ISO-160 flanges and Viton O-ring seals

All dimensions are in inches (mm) & weights are in pounds (kg), unless otherwise noted.

Downstream Pressure Control

Throttling SoftShut Gate Valves



Throttling SoftShut Valves

MODEL NUMBER	NOM. ID	FLANGE TYPE	A	B	C	D	E	F	G	H	I	N	M	L	WT.
TSS-250-ISO-63	2.5	ISO-63	10.2 (260)	5.83 (148)	11.8 (299)	4.37 (111)	2.60 (67.0)	2.76 (70.1)	5.12 (130)	2.76 (70.1)	5.44 (138)	4	M8	(17)	19 (8.6)
TSS-300-ISO-80	3	ISO-80	10.4 (265)	6.30 (160)	12.6 (319)	5.04 (128)	2.68 (68.0)	3.27 (83.0)	5.71 (145)	2.76 (70.1)	5.33 (135)	8	M8	(14)	27 (12.3)
TSS-400-ISO-100	4	ISO-100	11.1 (281)	7.17 (182)	15.0 (381)	5.91 (150)	2.90 (73.0)	4.02 (102)	6.50 (165)	2.76 (70.1)	5.61 (143)	8	M8	(15)	36 (16.3)
TSS-600-ISO-160	6	ISO-160	12.5 (318)	10.1 (256)	19.3 (489)	8.78 (223)	3.10 (78.0)	6.02 (153)	8.86 (225)	3.15 (80.0)	6.04 (153)	8	M10	(16)	61 (27.7)
TSS-800-ISO-200	8	ISO-200	13.7 (349)	12.4 (315)	23.4 (594)	11.1 (283)	3.20 (82.0)	8.39 (213)	11.2 (285)	3.15 (80.0)	6.41 (163)	12	M10	(15)	87 (39.5)
TSS-1000-ISO-250	10	ISO-250	14.7 (374)	14.4 (366)	27.5 (699)	13.1 (333)	3.50 (90.0)	10.3 (261)	13.2 (335)	3.94 (100)	6.96 (177)	12	M10	(21)	114 (51.8)
TSS-250-CF-450	2.5	CF-450	10.2 (260)	5.80 (148)	11.8 (299)	4.37 (111)	2.60 (67.0)	2.76 (70.1)	4.45 (113)	2.76 (70.1)	5.44 (138)	8	M8	(17)	19 (8.6)
TSS-400-CF-600	4	CF-600	11.1 (281)	7.20 (182)	15.0 (381)	5.91 (150)	2.90 (73.0)	4.00 (102)	5.95 (151)	2.76 (70.1)	5.61 (143)	16	M8	(15)	36 (16.3)
TSS-600-CF-800	6	CF-800	12.5 (318)	10.1 (256)	19.3 (489)	8.78 (223)	3.10 (78.0)	6.00 (153)	8.00 (203)	3.15 (80.0)	6.04 (153)	20	M8	(17)	61 (27.7)
TSS-800-CF-1000	8	CF-1000	13.7 (349)	12.4 (315)	23.4 (594)	11.1 (283)	3.20 (82.0)	7.99 (203)	10.7 (273)	3.15 (80.0)	6.41 (163)	24	M8	(15)	87 (39.5)
TSS-1000-CF-1200	10	CF-1200	14.7 (374)	14.4 (366)	27.5 (699)	13.1 (333)	3.50 (90.0)	10.0 (254)	12.0 (305)	3.94 (100)	6.96 (177)	32	M8	(20)	114 (51.8)

N=Number bolt holes M=Thread bolt diameter L=Thread depth

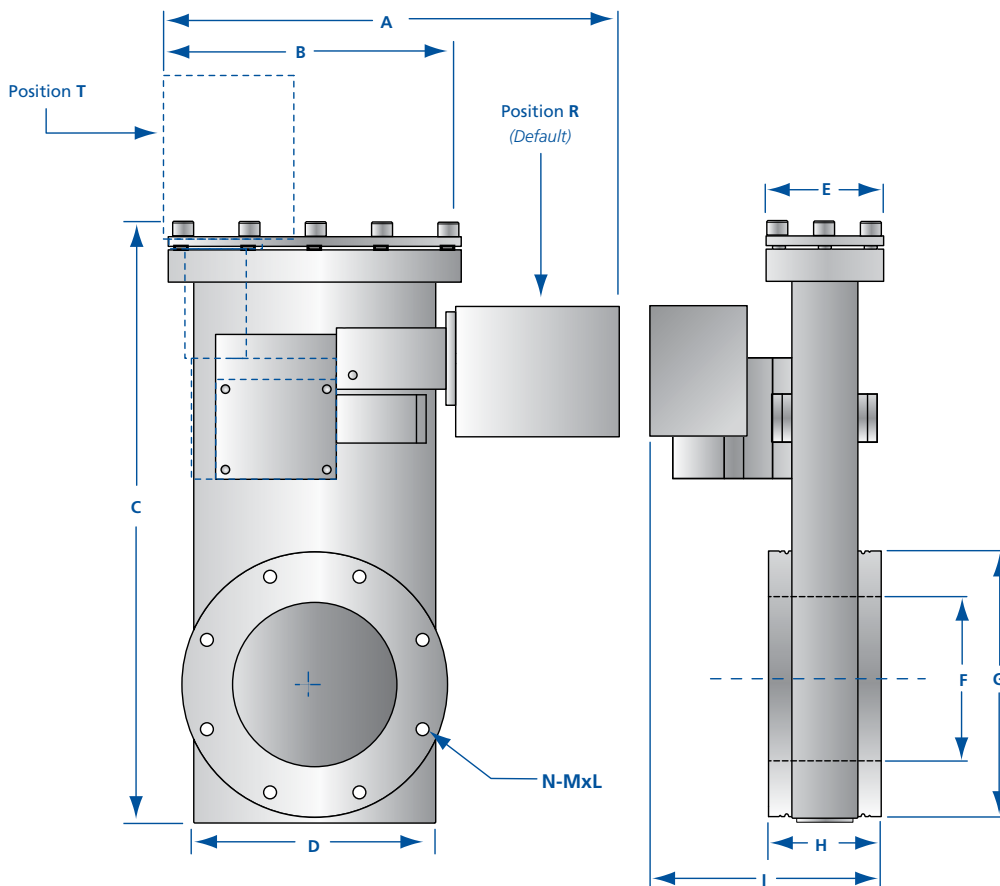

SPECIFICATIONS

General

Compatible controllers: 700-series APC buried box controllers

Valve position: Visual indicator

Construction

Wetted materials: 304 stainless steel, phosphor-bronze guide pins and Viton seals
Seals: Viton standard. Kalrez, Chemraz and Perlast and other materials available

Operation

Power input: Supplied by APC controller. Refer to APC section.

Differential pressure:
 With valve fully sealed: 2.1 bar max, all sizes
 (except DN250 at 1.3 bar max)

While opening the valve: 1 bar max (DN63, DN80, DN100 and DN160)
 307 mbar max (DN200 and DN250)

Operating pressure: 1.0×10^{-8} to 1 bar

Heating or bakeout capabilities:

Body: 150°C maximum with heater kits

Actuator: 60°C maximum

Ambient operating conditions:

0 - 60°C @ 0 - 95% humidity, noncondensing

Leak rate: 1×10^{-9} mbar-liter/sec He across seat and to atmosphere

Inherent performance

Maximum speed: Open to closed in 1 to 3 seconds, depending on size

Control resolution: 12 to 48 million steps, depending on valve size

Pressure control performance

(when used with an Intellisys controller)

Accuracy: The greater of 5 mV or 0.25% of reading

Repeatability: Within 2.5 mV or 0.12% of reading

Control range: 0.5% - 100% of the vacuum gauge range

Reliability

(99% confidence level, in clean environment)

O-ring cycle life: 1 million cycles open to control closed. 200K cycles open to fully closed.

MTBF: >10,000 hrs. continuous operation

Approvals

CE (EMC and Low Voltage Directives)

All dimensions are in inches (mm) & weights are in pounds (kg), unless otherwise noted.

Downstream Pressure Control IQ Throttling SoftShut Gate Valves



IQ Throttling SoftShut Valves

MODEL NUMBER	ID	FLANGE TYPE	A	B	C	D	E	F	G	H	I	N	M	L	WT.
TSS-IQA-250-ISO-63	2.5	ISO-63	11.7 (297)	5.83 (148)	11.8 (299)	4.37 (111)	2.60 (67.0)	2.76 (70.1)	5.12 (130)	2.76 (70.1)	5.61 (143)	4	M8	(17)	19 (8.6)
TSS-IQA-300-ISO-80	3	ISO-80	12.9 (328)	6.30 (160)	12.6 (319)	5.04 (128)	2.68 (68.0)	3.27 (83.0)	5.71 (145)	2.76 (70.1)	5.51 (140)	8	M8	(14)	27 (12.3)
TSS-IQA-400-ISO-100	4	ISO-100	12.6 (319)	7.17 (182)	15.0 (381)	5.91 (150)	2.90 (73.0)	4.02 (102)	6.50 (165)	2.76 (70.1)	5.79 (147)	8	M8	(15)	36 (16.3)
TSS-IQA-600-ISO-160	6	ISO-160	14.0 (356)	10.1 (256)	19.3 (489)	8.78 (223)	3.10 (78.0)	6.02 (153)	8.86 (225)	3.15 (80.0)	6.23 (158)	8	M10	(16)	61 (27.7)
TSS-IQA-800-ISO-200	8	ISO-200	15.3 (387)	12.4 (315)	23.4 (594)	11.1 (283)	3.20 (82.0)	8.39 (213)	11.2 (285)	3.15 (80.0)	6.56 (167)	12	M10	(15)	87 (39.5)
TSS-IQA-1000-ISO-250	10	ISO-250	16.3 (413)	14.4 (366)	27.5 (699)	13.1 (333)	3.50 (90.0)	10.3 (261)	13.2 (335)	3.94 (100)	7.13 (181)	12	M10	(21)	114 (51.8)
TSS-IQA-250-CF-450	2.5	CF-450	11.7 (297)	5.80 (148)	11.8 (299)	4.37 (111)	2.60 (67.0)	2.76 (70.1)	4.45 (113)	2.76 (70.1)	5.61 (143)	8	M8	(17)	19 (8.6)
TSS-IQA-400-CF-600	4	CF-600	12.8 (319)	7.20 (182)	15.0 (381)	5.91 (150)	2.90 (73.0)	4.00 (102)	5.95 (151)	2.76 (70.1)	5.79 (147)	16	M8	(15)	36 (16.3)
TSS-IQA-600-CF-800	6	CF-800	14.0 (356)	10.1 (256)	19.3 (489)	8.78 (223)	3.10 (78.0)	6.00 (153)	8.00 (203)	3.15 (80.0)	6.23 (158)	20	M8	(17)	61 (27.7)
TSS-IQA-800-CF-1000	8	CF-1000	15.3 (387)	12.4 (315)	23.4 (594)	11.1 (283)	3.20 (82.0)	7.99 (203)	10.7 (273)	3.15 (80.0)	6.56 (167)	24	M8	(15)	87 (39.5)
TSS-IQA-1000-CF-1200	10	CF-1200	16.3 (413)	14.4 (366)	27.5 (699)	13.1 (333)	3.50 (90.0)	10.0 (254)	12.0 (305)	3.94 (100)	6.13 (158)	32	M8	(20)	114 (51.8)

SPECIFICATIONS

General operation

Controller Options :

- IQA: Analog / TTL / RS232 interface
- IQD: DeviceNet / RS232 interface
- IQD2: DeviceNet / RS232 interface, no power via DN connector
- IQE: Ethernet / RS232 interface
- IQR: RS485 interface

Valve position: Visual indicator

Construction

- Wetted materials:** 304 stainless steel, phosphor-bronze guide pins and Viton seals
- Seals:** Viton standard. Kalrez, Chemraz and Perlast and other materials available.

Operation

IQ controller power input: +24 VDC @ 3A, +/- 10%

Differential pressure:

With valve fully sealed: 2.1 bar max, all sizes (except DN250 at 1.3 bar max)

While opening the valve: 1 bar max (DN63, DN80, DN100 & DN160)

307 mbar max (DN200 & DN250)

Operating pressure:

1.0 x 10⁻⁸ to 1 bar

Heating or bakeout capabilities:

Body: 150°C max with optional heater kits

Actuator: 60°C maximum

Ambient operating conditions:

0 - 45°C @ 0 - 95% humidity, non-condensing

Leak rate:

1 x 10⁻⁹ mbar-liter sec⁻¹ He across seat and to atmosphere.

Inherent performance

Maximum speed: Open to closed in 1 to 3 seconds, depending on size

Control resolution: 12 to 48 million steps, depending on valve size

Pressure control performance

(99% confidence level, in clean environment)

Accuracy: The greater of 5 mV or 0.25% of reading

Repeatability: Within 2.5 mV or 0.12% of reading

Control range: 0.5% - 100% of the vacuum gauge range

Reliability

(99% confidence level, in clean environment)

MTBF: >10,000 hours continuous operation

Approvals

CE (EMC and Low Voltage Directives)

Note: IQA can be replaced with IQD, IQD2, IQE and IQR

N=Number bolt holes M=Thread bolt diameter L=Thread depth

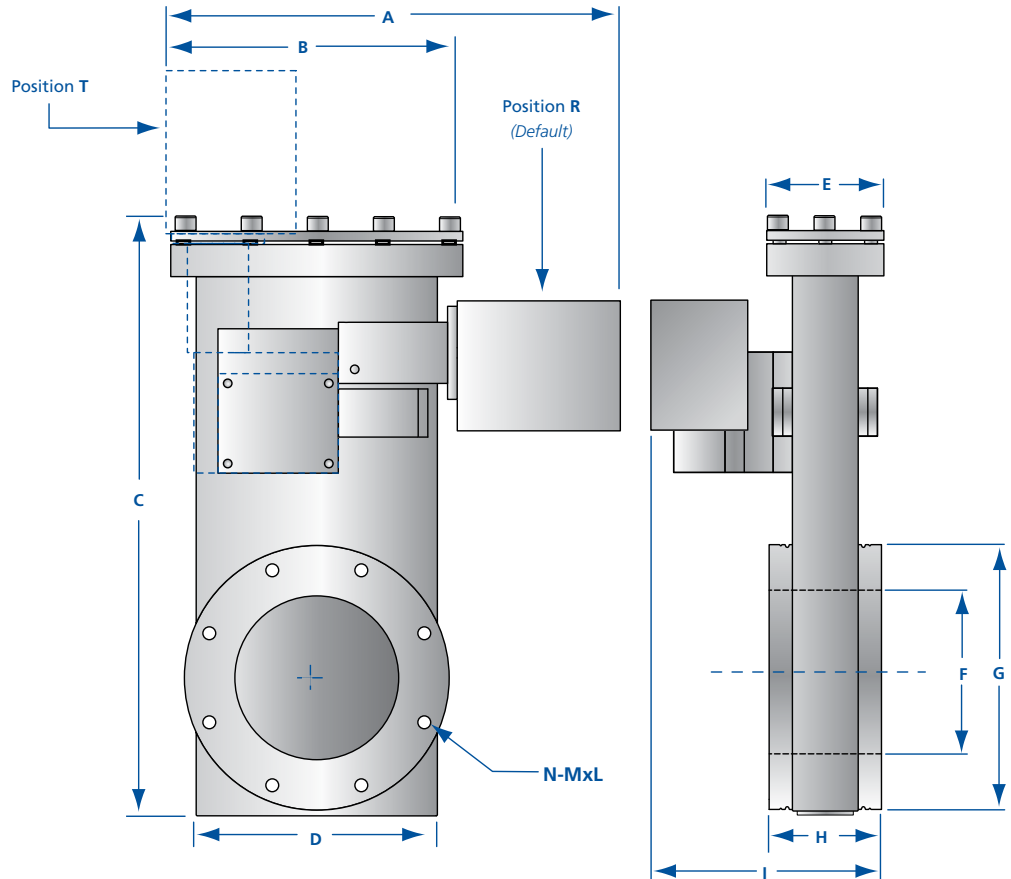

All dimensions are in inches (mm) & weights are in pounds (kg), unless otherwise noted.



Advanced Control System Performance

The Intellisys Adaptive Pressure Controller (APC) provides advanced control system performance by combining closed loop motor control with adaptive pressure control. APCs are available in two basic configurations – the buried box style and the new on-valve IQ-series. The patented closed loop motor control technology, found at the core of the Intellisys controller technology, results in 250 times

greater motor positional resolution at 10-20 times the speed compared to other existing technologies. The adaptive pressure control algorithm eliminates pressure over- and under-shoots as well as ringing during process step transitions.

APC controllers are available for all of Nor-Cal's Intellisys control valves and

drives, and can be supplied with auto-ranging AC, or low voltage DC power supplies. Depending on the model and intended valve operation, users can choose from additional optional features such as battery back-up, local and remote displays and a range of communication modes including Analog/TTL, RS-232 and RS-485 serial, as well as DeviceNet.

Low Voltage Controllers

MODEL NUMBER	FOR USE WITH	BATTERY BACK-UP	WEIGHT
APC-100L-A	Geared Butterfly Valves (TBV-G-xxx)	NO	1.6 (0.7)
APC-100L-AB	Geared Butterfly Valves (TBV-G-xxx)	YES	2.5 (1.1)
APC-200L-A	Direct Drive Butterfly Valves (TBV-D-xxx)	NO	1.6 (0.7)
APC-200L-AB	Direct Drive Butterfly Valves (TBV-D-xxx)	YES	2.5 (1.1)
APC-300L-A	Sealing Butterfly Valves (TBVS-G-xxx)	NO	1.6 (0.7)
APC-300L-AB	Sealing Butterfly Valves (TBVS-G-xxx)	YES	2.5 (1.1)
APC-700L-A	SoftShut Linear Gate Valves (TSS-xxx)	NO	1.6 (0.7)
APC-700L-AB	SoftShut Linear Gate Valves (TSS-xxx)	YES	2.5 (1.1)
APC-800L-A	Pendulum Valves (TPV-xxx)	NO	1.6 (0.7)
APC-800L-AB	Pendulum Valves (TPV-xxx)	YES	2.5 (1.1)

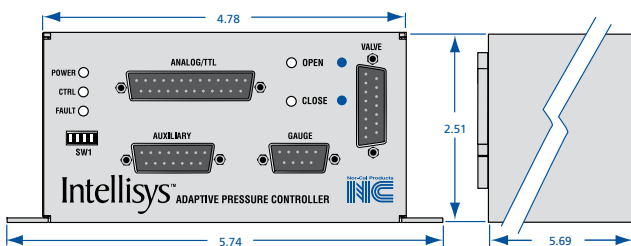

Low Voltage Controllers with DeviceNet

MODEL NUMBER	FOR USE WITH	BATTERY BACK-UP	WEIGHT
APC-100L-D	Geared Butterfly Valves (TBV-G-xxx)	NO	1.6 (0.7)
APC-100L-DB	Geared Butterfly Valves (TBV-G-xxx)	YES	2.5 (1.1)
APC-200L-D	Direct Drive Butterfly Valves (TBV-D-xxx)	NO	1.6 (0.7)
APC-200L-DB	Direct Drive Butterfly Valves (TBV-D-xxx)	YES	2.5 (1.1)
APC-300L-D	Sealing Butterfly Valves (TBVS-G-xxx)	NO	1.6 (0.7)
APC-300L-DB	Sealing Butterfly Valves (TBVS-G-xxx)	YES	2.5 (1.1)
APC-700L-D	SoftShut Linear Gate Valves (TSS-xxx)	NO	1.6 (0.7)
APC-700L-DB	SoftShut Linear Gate Valves (TSS-xxx)	YES	2.5 (1.1)
APC-800L-D	Pendulum Valves (TPV-xxx)	NO	1.6 (0.7)
APC-800L-DB	Pendulum Valves (TPV-xxx)	YES	2.5 (1.1)

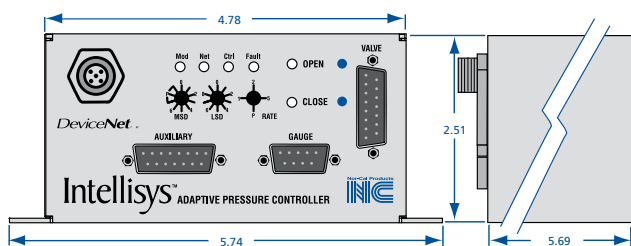

SPECIFICATIONS

General

Construction material

Chassis: 5052-aluminum

Power input: +24 VDC +/-10%, 100W

max (600W nonminal) power input

Battery back-up: Optional

Ambient operating conditions: 0 - 45°C @ 0 - 95% humidity, non-condensing

System interface

Serial communication: RS-232 or RS-485 on DB-15 female connector..

Analog/TTL communication: Four (4) analog I/O and seven (7) TTL I/O on DB-25 female connector

DeviceNet communication: Micro-style 5-pin male connector

Analog setpoint input: 0-10 or 0-5 VDC linearly proportional to pressure or valve position

Pressure output: 0-10 VDC analog output proportional to pressure, one for each vacuum gauge attached

Valve position output: 0-10 VDC or 0-5 VDC analog output proportional to valve position

Device interface

Gauge connection: Differential analog signal input with ±15 VDC power output to one or two gauges

Valve connection: DB-15 female connector provides power and transmits position information required to operate the high performance valve

User Interface

Switches: Valve open & close, and multi-position rotary switches for communications settings

Indicating LED's Power, Fault, Control, Valve open and closed, DeviceNet: Mod and Net

Pressure Control Performance

Accuracy: The greater of 5 mV or 0.25% of reading

Repeatability: Within 2.5 mV or 0.12% of reading

Control range: 0.5% - 100% of the vacuum gauge range

Reliability

(99% confidence level, in clean environment)

MTBF: >50,000 hours continuous operation

Approvals

CE (EMC and Low Voltage Directives)

NRTL (United States)

SCC (Canada)

EU Directives (Europe)

All dimensions are in inches (mm) & weights are in pounds (kg), unless otherwise noted.

Downstream Pressure Control

Adaptive Pressure Controllers



SPECIFICATIONS

Construction

Construction material

Chassis: 5052-aluminum

Power input: 100-240 VAC, 50-60Hz, 100W max (60W nominal) power input.

Battery Back-up: N/A

Ambient operating conditions: 0-45°C @ 0-95% humidity, non-condensing

System interface

Serial communication: RS-232 or RS-485 on DB-9 female connector.

Analog / TTL communication: Six (6) analog I/O and thirteen (13) TTL I/O on DB-37 female connector

DeviceNet communication: N/A

Analog setpoint input: 0-10 or 0-5 VDC linearly proportional to pressure or valve position

Pressure output: 0-10 VDC analog output proportional to pressure, one for each vacuum gauge attached

Valve position output: 0-10 VDC or 0-5 VDC analog output proportional to valve position

Device interface

Gauge connection: Differential analog signal input with ± 15 VDC power output to one or two gauges

Valve connection: DB-15 female connector provides power and transmits position information required to operate the high performance valve

User interface

Switches: Power ON/OFF, Valve OPEN / CLOSE

Indicating LEDs: Power, Fault, Control, Valve open and closed

Graphic display: N/A

(Touch screen LCD on listed model)

Pressure control performance

Accuracy: The greater of 5 mV or 0.25% of reading

Repeatability: Within 2.5 mV or 0.12% of reading

Control range: 0.5% - 100% of the vacuum gauge range

Reliability

(99% confidence level, in clean environment)

MTBF: >50,000 hours continuous operation

Approvals

CE (EMC and Low Voltage Directives)

NRTL (United States)

SCC (Canada)

EU Directives (Europe)

A/C Adaptive Pressure Controllers

MODEL NUMBER	FOR USE WITH	BATTERY BACK-UP	WEIGHT
APC-100-A	Geared Butterfly Valves (TBV-G-xxx)	NO	3.5 (1.6)
APC-200-A	Direct Drive Butterfly Valves (TBV-D-xxx)	NO	3.5 (1.6)
APC-300-A	Sealing Butterfly Valves (TBVS-G-xxx)	NO	3.5 (1.6)
APC-700-A	SoftShut Linear Gate Valves (TSS-xxx)	NO	3.5 (1.6)
APC-800-A	Pendulum Valves (TPV-xxx)	NO	3.5 (1.6)

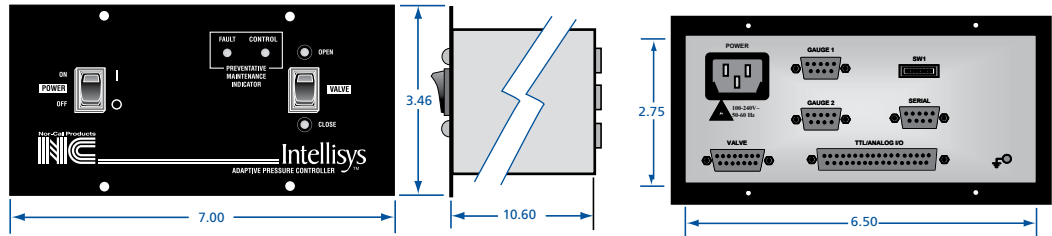

A/C Adaptive Pressure Controllers with Touch Screen

MODEL NUMBER	FOR USE WITH	BATTERY BACK-UP	WEIGHT
APC-150-A	Geared Butterfly Valves (TBV-G-xxx)	NO	4.2 (1.9)
APC-250-A	Direct Drive Butterfly Valves (TBV-D-xxx)	NO	4.2 (1.9)
APC-350-A	Sealing Butterfly Valves (TBVS-G-xxx)	NO	4.2 (1.9)
APC-750-A	SoftShut Linear Gate Valves (TSS-xxx)	NO	4.2 (1.9)
APC-850-A	Pendulum Valves (TPV-xxx)	NO	4.2 (1.9)

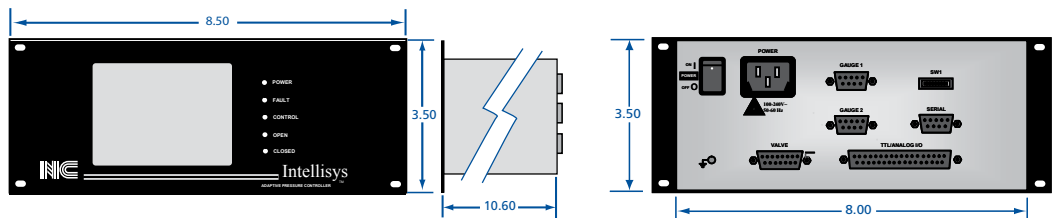

All dimensions are in inches (mm) & weights are in pounds (kg), unless otherwise noted.

Downstream Pressure Control

Capacitance Diaphragm Gauges



The **CMG-025-series Capacitance Diaphragm Gauge** line of economical miniature manometers is designed for stable performance in manufacturing tool environments. The corrosion resistant Inconel sensor provides excellent zero stability with a long life expectancy of several million pressure cycles, including atmospheric bursts. A robust mechanical design and digital electronics improve EMC compatibility, long term stability and temperature compensation. The **CMG-025-series** sets new standards for fast stability after power on and fast recovery from atmospheric pressure exposure.

Advantages

- Full scale ranges from 10 Torr to 1000 Torr
- Fast stability after power on
- Fast recovery from atmospheric pressure
- Corrosion resistant Inconel sensor
- Excellent long term signal stability
- Temperature compensated
- Wide range power supply 12-30 VDC

MODEL NUMBER	F.S. RANGE	TUBE FITTING	HEATED
CMG-025-T11	10 Torr	1/2" Tube End	NO
CMG-025-T11-NW1	10 Torr	NW-16	NO
CMG-025-T11-VCR	10 Torr	1/2" FVCR	NO
CMG-025-T12	20 Torr	1/2" Tube End	NO
CMG-025-T12-NW1	20 Torr	NW-16	NO
CMG-025-T12-VCR	20 Torr	NW-16	NO
CMG-025-T21	100 Torr	1/2" Tube End	NO
CMG-025-T21-NW1	100 Torr	NW-16	NO
CMG-025-T21-VCR	100 Torr	1/2" FVCR	NO
CMG-025-T31	1,000 Torr	1/2" Tube End	NO
CMG-025-T31-NW1	1,000 Torr	NW-16	NO
CMG-025-T31-VCR	1,000 Torr	1/2" FVCR	NO

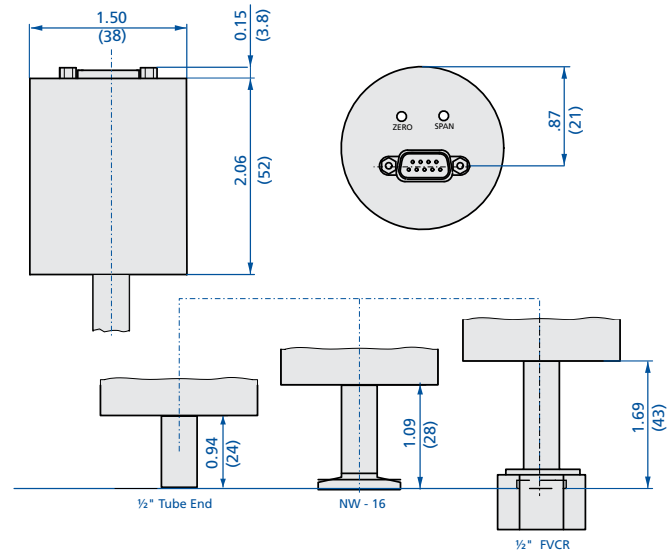

MEASUREMENT RANGE F.S. (FULL SCALE)	TORR	MEASUREMENT RANGE			
		1000	100	20	10
Accuracy ¹⁾	% of reading	0.5	0.5	0.5	0.5
Temperature effect on zero	% F.S./°C	0.005	0.005	0.005	0.005
Temperature effect on span	% of reading/°C	0.03	0.03	0.03	0.03
Resolution	% F.S.	0.01	0.01	0.01	0.01
Pressure, max.	psia	45	45	45	45
Response Time ²⁾	ms	20	20	20	20
Lowest reading	% F.S.	0.05	0.05	0.1	0.05
Lowest suggested reading	% F.S.	0.05	0.05	0.1	0.05
Lowest suggested control pressure	% F.S.				
Temperature Operation (ambient)	°C	+5 to +50			
Bakeout at flange ³⁾	°C	≤110			
Storage	°C	-40 to +65			
Supply voltage	VDC	12 to 32			
Power consumption	W	≤ 0.2			
Output signal (analog)	VDC	0 to +10			
Standards		CE:EMG 89/336/EEC			
Electrical connection		D-sub, 9 pin, male			
Materials exposed to vacuum		INCONEL, SS316			

¹⁾ Non-linearity, hysteresis, repeatability at 25°C ambient operating temperature without temperature effects after 2 hours operation.
²⁾ Increase 10 to 90% F.S. ³⁾ 18% Cr, 10% Ni, 3% Mo, 69% Fe

All dimensions are in inches (mm) & weights are in pounds (kg), unless otherwise noted.

Downstream Pressure Control Capacitance Diaphragm Gauges



Measurements of Superior Accuracy and Repeatability

The **CDG025-series Capacitance Diaphragm Gauge** line of highly accurate temperature compensated manometers is designed for stable performance in harsh manufacturing tool environments. Advanced digital electronics improve gauge performance and offer easy handling features such as one push button zero function and set point adjustment. The corrosion resistant ultra pure ceramic sensor provides excellent zero stability with a long life expectancy of several million pressure cycles, including atmospheric bursts. A robust mechanical design and digital electronics improve EMC compatibility, long term stability and temperature compensation. The **CDG025-series** sets new standards for fast stability after power on and fast recovery from atmospheric pressure exposure.

Advantages

- Full scale ranges from 1 Torr to 1000 Torr
- Fast stability after power on
- Fast recovery from atmospheric pressure
- Corrosion resistant ceramic sensor
- Temperature compensated
- Sensor protected from contamination
- One push button zero function
- Wide range power supply
- Excellent long term signal stability

MODEL NUMBER	F.S. RANGE	TUBE FITTING	HEATED
CDG025-T01	1 Torr	1/2" Tube End	NO
CDG025-T01-CF	1 Torr	1.33" CF	NO
CDG025-T01-NW1	1 Torr	NW-16	NO
CDG025-T01-VCR	1 Torr	1/2" FVCR	NO
CDG025-T02	2 Torr	1/2" Tube End	NO
CDG025-T02-CF	2 Torr	1.33" CF	NO
CDG025-T02-NW1	2 Torr	NW-16	NO
CDG025-T02-VCR	2 Torr	1/2" FVCR	NO
CDG025-T11	10 Torr	1/2" Tube End	NO
CDG025-T11-CF	10 Torr	1.33" CF	NO
CDG025-T11-NW1	10 Torr	NW-16	NO
CDG025-T11-VCR	10 Torr	1/2" FVCR	NO
CDG025-T12	20 Torr	1/2" Tube End	NO
CDG025-T12-CF	20 Torr	1.33" CF	NO
CDG025-T12-NW1	20 Torr	NW-16	NO
CDG025-T12-VCR	20 Torr	1/2" FVCR	NO
CDG025-T21	100 Torr	1/2" Tube End	NO
CDG025-T21-CF	100 Torr	1.33" CF	NO
CDG025-T21-NW1	100 Torr	NW-16	NO
CDG025-T21-VCR	100 Torr	1/2" FVCR	NO
CDG025-T31	1,000 Torr	1/2" Tube End	NO
CDG025-T31-CF	1,000 Torr	1.33" CF	NO
CDG025-T31-NW1	1,000 Torr	NW-16	NO
CDG025-T31-VCR	1,000 Torr	1/2" FVCR	NO

	INTERNAL VOLUME in ³ (cm ³)	WEIGHT grams
1/2" Tube End	0.22 (3.6)	310
NW - 16	0.22 (3.6)	330
1.33 CF	0.22 (3.6)	350
1/2" FVCR®	0.22 (3.6)	370

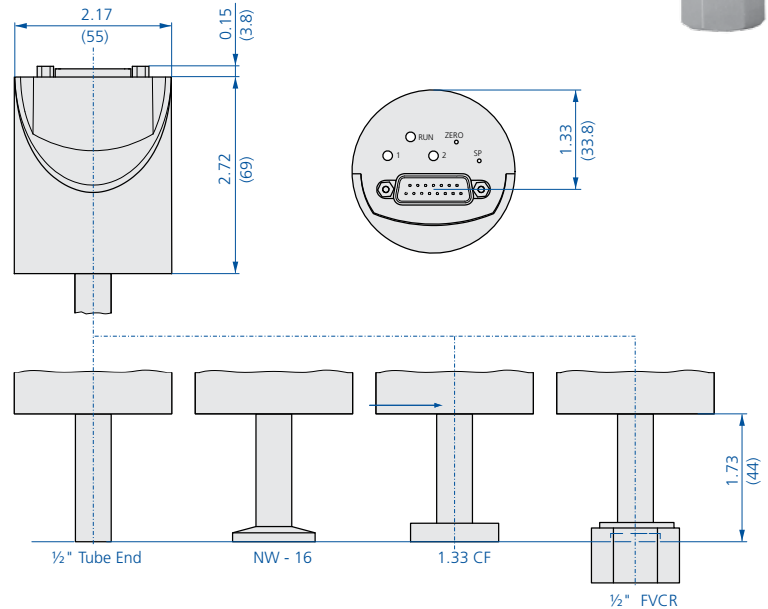

MEASUREMENT RANGE F.S. (FULL SCALE)	TORR	MEASUREMENT RANGE			
		1000	100	20/10	2/1
Accuracy ¹⁾	% of reading	0.2	0.2	0.2	0.2
Temperature effect on zero	% F.S./°C	0.005	0.005	0.005	0.015
on span	% of reading/°C	0.01	0.01	0.01	0.01
Resolution	% F.S.	0.003	0.003	0.003	0.003
Pressure, max.	kPa (absolute)	400	260	260	260
Response Time ²⁾	ms	30	30	30	30
Lowest reading	% F.S.			0.01	
Lowest suggested reading	% F.S.			0.05	
Lowest suggested control pressure	% F.S.			0.05	
Temperature Operation (ambient)	°C			+5 to +50	
Bakeout at flange ³⁾	°C			≤110	
Storage	°C			-40 to +65	
Supply voltage	VDC			14 to +30	
Power consumption	W			≤1	
Output signal (analog)	VDC			0 to +10	
Degree of protection				IP 30	
Standards		EN 61000-6-2, EN 6100-6-3, EN 61010, UL 61010-1, CSA 22.2 No. 61010-1, RoHS			
Electrical connection		D-sub, 15 pin, male			
Materials exposed to vacuum		Aluminum oxide ceramic (A203), Vacon 70 ⁴⁾ , stainless steel (AISI 316L ⁵⁾ , AgCuTi hard solder, sealing glass			

¹⁾ Non-linearity, hysteresis, repeatability at 25°C ambient operating temperature without temperature effects after 2 hours operation.

²⁾ Incease 10 to 90% F.S. ³⁾ Non operation

⁴⁾ 28% Ni, 23% Co, 49% Fe ⁵⁾ 18% Cr, 10% Ni, 3% Mo, 69% Fe

Downstream Pressure Control Capacitance Diaphragm Gauges



The **CDG045-series** manometers are your best choice for high accurate total pressure measurement and control.

Advantages

- Lower cost of ownership, 50% faster warm up, energy efficient low power consumption
- Easy integration, wide variety of full scales, flanges and interfaces, standard with two set points
- Easy one push button or remote signal zero command, zero offset adjustable
- Two year warranty, longer life time with advanced heating concept and gauge protection
- No long term recalibration due to excellent signal stability and repeatability, even in harsh plasma applications
- Diagnostic port for quick service and maintenance
- Compliance & standards: CE, EN, UL, SEMI, RoHS

MODEL NUMBER	F.S. RANGE	TUBE FITTING	HEATED
CDG045-M11	100 mTorr	1/2" Tube End	45°C
CDG045-M11-CF	100 mTorr	1.33" CF	45°C
CDG045-M11-NW1	100 mTorr	NW-16	45°C
CDG045-M11-VCR	100 mTorr	1/2" FVCR	45°C
CDG045-T01	1 Torr	1/2" Tube End	45°C
CDG045-T01-CF	1 Torr	1.33" CF	45°C
CDG045-T01-NW1	1 Torr	NW-16	45°C
CDG045-T01-VCR	1 Torr	1/2" FVCR	45°C
CDG045-T02	2 Torr	1/2" Tube End	45°C
CDG045-T02-CF	2 Torr	1.33" CF	45°C
CDG045-T02-NW1	2 Torr	NW-16	45°C
CDG045-T02-VCR	2 Torr	1/2" FVCR	45°C
CDG045-T11	10 Torr	1/2" Tube End	45°C
CDG045-T11-CF	10 Torr	1.33" CF	45°C
CDG045-T11-NW1	10 Torr	NW-16	45°C
CDG045-T11-VCR	10 Torr	1/2" FVCR	45°C
CDG045-T12	20 Torr	1/2" Tube End	45°C
CDG045-T12-CF	20 Torr	1.33" CF	45°C
CDG045-T12-NW1	20 Torr	NW-16	45°C
CDG045-T12-VCR	20 Torr	1/2" FVCR	45°C
CDG045-T21	100 Torr	1/2" Tube End	45°C
CDG045-T21-CF	100 Torr	1.33" CF	45°C
CDG045-T21-NW1	100 Torr	NW-16	45°C
CDG045-T21-VCR	100 Torr	1/2" FVCR	45°C
CDG045-T31	1,000 Torr	1/2" Tube End	45°C
CDG045-T31-CF	1,000 Torr	1.33" CF	45°C
CDG045-T31-NW1	1,000 Torr	NW-16	45°C
CDG045-T31-VCR	1,000 Torr	1/2" FVCR	45°C

	INTERNAL VOLUME in ³ (cm ³)	WEIGHT grams
1/2" Tube End	0.26 (4.2)	837
NW - 16	0.26 (4.2)	852
1.33 CF	0.26 (4.2)	875
1/2" FVCR®	0.26 (4.2)	897

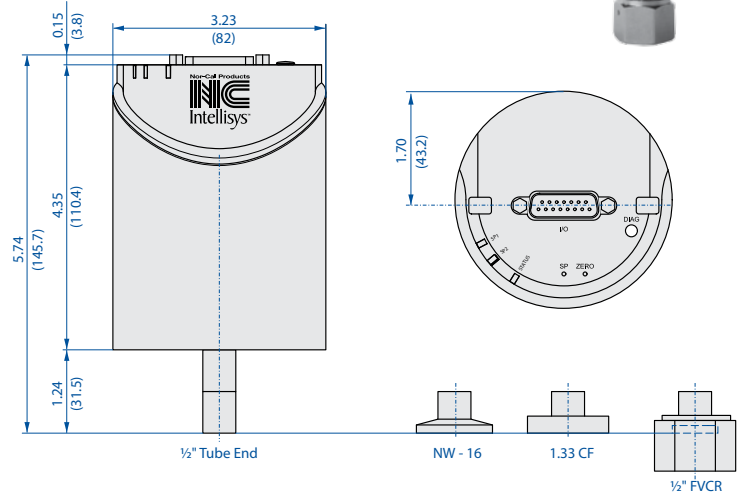

MEASUREMENT RANGE F.S. (FULL SCALE)	TORR	1000	100	20/10	2/1	0.1
Accuracy ¹⁾	% of reading					0.15
Temperature effect on zero on span	% F.S. / °C					0.0025
	% of reading / °C					0.01
Pressure, max.	kPa (absolute)	400		260		130
Resolution	% F.S.			0.003		
Lowest reading	% F.S.			0.01		
Lowest suggested reading	% F.S.			0.05		
Lowest suggested control pressure	% F.S.			0.05		
Temperature Operation (ambient)	°C			+10 to +40		
Bakeout at flange	°C			≤110		
Storage	°C			-40 to +65		
Supply voltage				+14 to +30 VDC or ± 15 V (±5%)		
Power consumption During Heat up	W			≤12		
At operating temperature	W			≤8		
Output signal (analog)	VDC			0 to +10		
Response time ²⁾	ms			30		130
Degree of protection				IP 40		
Standards				EN 61000-6-2/6-3, EN 61010, UL 61010-1, CSA 22.2 No. 61010-1, SEMI S-2		
Electrical connection				D-sub, 15 pin, male		
Set point Relay Contact Hysteresis	VDC / ADC % F.S.			two set points (SPT, SP2) ≤30 / ≤0.5 1		
Diagnostic port Protocol Reed Set				RS232-C Pressure, status, ID, set points, filter, zero adjust, factory reset, DC offset		
Materials exposed to vacuum				Aluminum oxide ceramic (A203), stainless steel (AISI 316L ³⁾ , Nickel, sealing glass		

¹⁾ Non-linearity, hysteresis, repeatability at 25°C ambient operating temperature without temperature effects after 2 hours operation.
²⁾ Incease 10 to 90% F.S. ³⁾ 18% Cr, 10% Ni, 3% Mo, 69% Fe



Downstream Pressure Control Capacitance Diaphragm Gauges

CDG100-series gauges are temperature controlled at 100°C for superior performance in demanding semiconductor and plasma processes.

Advantages

- Lower cost of ownership, 50% faster warm up, energy efficient low power consumption
- Easy integration, wide variety of full scales, flanges and interfaces, standard with two set points
- Easy one push button or remote signal zero command, zero offset adjustable
- Two year warranty, longer life time with advanced heating concept and gauge protection
- No long term recalibration due to excellent signal stability and repeatability, even in harsh plasma applications
- Diagnostic port for quick service and maintenance
- Compliance & standards: CE, EN, UL, SEMI, RoHS

MODEL NUMBER	F.S. RANGE	TUBE FITTING	HEATED
CDG100-M11	100 mTorr	1/2" Tube End	100°C
CDG100-M11-CF	100 mTorr	1.33" CF	100°C
CDG100-M11-NW1	100 mTorr	NW-16	100°C
CDG100-M11-VCR	100 mTorr	1/2" FVCR	100°C
CDG100-T01	1 Torr	1/2" Tube End	100°C
CDG100-T01-CF	1 Torr	1.33" CF	100°C
CDG100-T01-NW1	1 Torr	NW-16	100°C
CDG100-T01-VCR	1 Torr	1/2" FVCR	100°C
CDG100-T02	2 Torr	1/2" Tube End	100°C
CDG100-T02-CF	2 Torr	1.33" CF	100°C
CDG100-T02-NW1	2 Torr	NW-16	100°C
CDG100-T02-VCR	2 Torr	1/2" FVCR	100°C
CDG100-T11	10 Torr	1/2" Tube End	100°C
CDG100-T11-CF	10 Torr	1.33" CF	100°C
CDG100-T11-NW1	10 Torr	NW-16	100°C
CDG100-T11-VCR	10 Torr	1/2" FVCR	100°C
CDG100-T12	20 Torr	1/2" Tube End	100°C
CDG100-T12-CF	20 Torr	1.33" CF	100°C
CDG100-T12-NW1	20 Torr	NW-16	100°C
CDG100-T12-VCR	20 Torr	1/2" FVCR	100°C
CDG100-T21	100 Torr	1/2" Tube End	100°C
CDG100-T21-CF	100 Torr	1.33" CF	100°C
CDG100-T21-NW1	100 Torr	NW-16	100°C
CDG100-T21-VCR	100 Torr	1/2" FVCR	100°C
CDG100-T31	1,000 Torr	1/2" Tube End	100°C
CDG100-T31-CF	1,000 Torr	1.33" CF	100°C
CDG100-T31-NW1	1,000 Torr	NW-16	100°C
CDG100-T31-VCR	1,000 Torr	1/2" FVCR	100°C

	INTERNAL VOLUME in ³ (cm ³)	WEIGHT grams
1/2" Tube End	0.26 (4.2)	837
NW - 16	0.26 (4.2)	852
1.33 CF	0.26 (4.2)	875
1/2" FVCR®	0.26 (4.2)	897

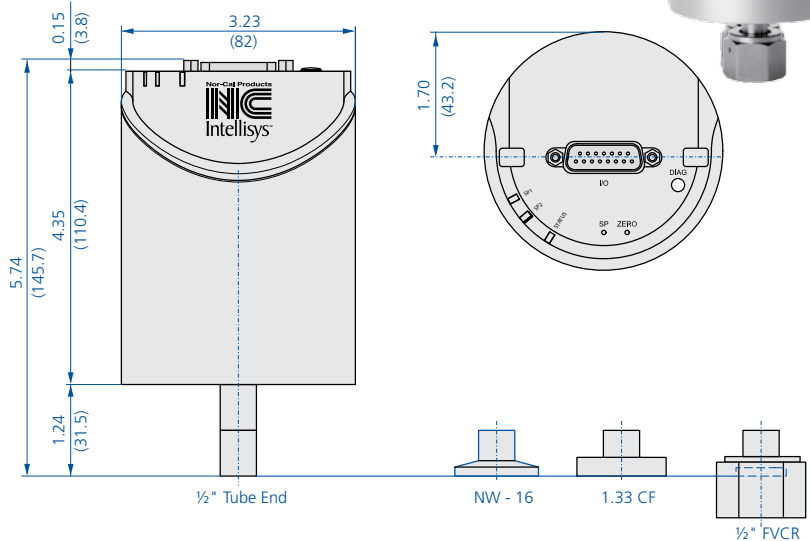

MEASUREMENT RANGE F.S. (FULL SCALE)	TORR	MEASUREMENT RANGE				
		1000	100	20/10	2/1	0.1
Accuracy ¹⁾	% of reading	0.2				
Temperature effect on zero on span	% F.S. / °C	0.00025				
	% of reading / °C	0.02				0.005
Pressure, max.	kPa (absolute)	400		260		130
Resolution	% F.S.	0.003				
Lowest reading	% F.S.	0.01				
Lowest suggested reading	% F.S.	0.05				
Lowest suggested control pressure	% F.S.	0.05				
Temperature Operation (ambient) Bakeout at flange Storage	°C	+10 to +50				
	°C	≤110				
	°C	-40 to +65				
Supply voltage		+14 to +30 VDC or ± 15 V (±5%)				
Power consumption During Heat up At operating temperature	W	≤15				
	W	≤10				
Output signal (analog)	VDC	0 to +10				
Response time ²⁾	ms	30				130
Degree of protection		IP 40				
Standards		EN 61000-6-2/6-3, EN 61010, UL 61010-1, CSA 22.2 No. 61010-1, SEMI S-2				
Electrical connection		D-sub, 15 pin, male				
Set point Relay Contact Hysteresis	VDC / ADC % F.S.	two set points (SPT, SP2) ≤30 / ≤0.5 1				
Diagnostic port Protocol Read Set		RS232-C Pressure, status, ID, set points, filter, zero adjust, factory reset, DC offset				
Materials exposed to vacuum		Aluminum oxide ceramic (A203), stainless steel (AISI 316L ³⁾ , Nickel, sealing glass				

¹⁾ Non-linearity, hysteresis, repeatability at 25°C ambient operating temperature without temperature effects after 2 hours operation.

²⁾ Incease 10 to 90% F.S. ³⁾ 18% Cr, 10% Ni, 3% Mo, 69% Fe

Downstream Pressure Control Capacitance Diaphragm Gauges



CDG160-series gauges are temperature controlled at 160°C for superior signal stability and repeatability.

Advantages

- Lower cost of ownership, 50% faster warm up, energy efficient low power consumption
- Easy integration, wide variety of full scales, flanges and interfaces, standard with two set point
- Easy one push button or remote signal zero command, zero offset adjustable
- Two year warranty, longer life time with advanced heating concept and gauge protection
- No long term recalibration due to excellent signal stability and repeatability, even in harsh plasma applications
- Diagnostic port for quick service and maintenance
- Compliance & standards: CE, EN, UL, SEMI, RoHS s

MODEL NUMBER	F.S. RANGE	TUBE FITTING	HEATED
CDG160-T01	1 Torr	1/2" Tube End	160°C
CDG160-T01-CF	1 Torr	1.33" CF	160°C
CDG160-T01-NW1	1 Torr	NW-16	160°C
CDG160-T01-FVCR	1 Torr	1/2" FVCR	160°C
CDG160-T02	2 Torr	1/2" Tube End	160°C
CDG160-T02-CF	2 Torr	1.33" CF	160°C
CDG160-T02-NW1	2 Torr	NW-16	160°C
CDG160-T02-FVCR	2 Torr	1/2" FVCR	160°C
CDG160-T11	10 Torr	1/2" Tube End	160°C
CDG160-T11-CF	10 Torr	1.33" CF	160°C
CDG160-T11-NW1	10 Torr	NW-16	160°C
CDG160-T11-FVCR	10 Torr	1/2" FVCR	160°C
CDG160-T12	20 Torr	1/2" Tube End	160°C
CDG160-T12-CF	20 Torr	1.33" CF	160°C
CDG160-T12-NW1	20 Torr	NW-16	160°C
CDG160-T12-FVCR	20 Torr	1/2" FVCR	160°C
CDG160-T21	100 Torr	1/2" Tube End	160°C
CDG160-T21-CF	100 Torr	1.33" CF	160°C
CDG160-T21-NW1	100 Torr	NW-16	160°C
CDG160-T21-FVCR	100 Torr	1/2" FVCR	160°C
CDG160-T31	1,000 Torr	1/2" Tube End	160°C
CDG160-T31-CF	1,000 Torr	1.33" CF	160°C
CDG160-T31-NW1	1,000 Torr	NW-16	160°C
CDG160-T31-FVCR	1,000 Torr	1/2" FVCR	160°C

	INTERNAL VOLUME in ³ (cm ³)	WEIGHT grams
1/2" Tube End	0.26 (4.2)	837
NW - 16	0.26 (4.2)	852
1.33 CF	0.26 (4.2)	875
1/2" FVCR®	0.26 (4.2)	897

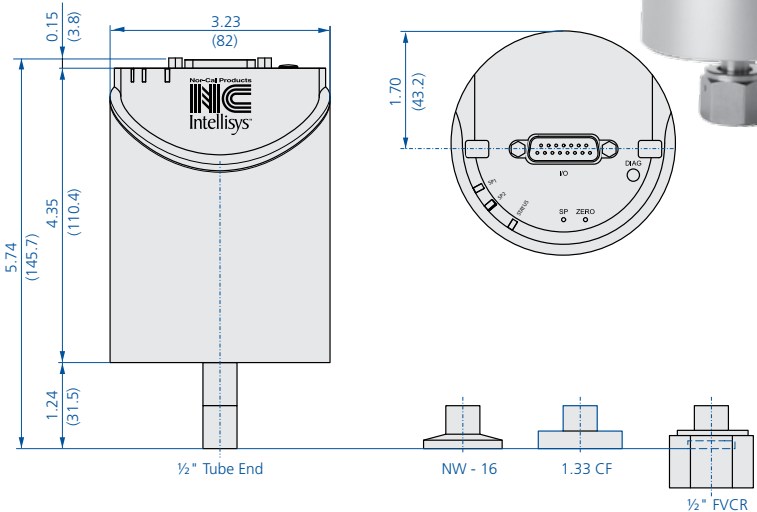

MEASUREMENT RANGE F.S. (FULL SCALE)	TORR	1000	100	20/10	2/1
Accuracy ¹⁾	% of reading				0.4
Temperature effect on zero	% F.S./°C				0.005
Temperature effect on span	% of reading/°C				0.02
Pressure, max.	kPa (absolute)	400		260	
Resolution	% F.S.			0.003	
Lowest reading	% F.S.			0.01	
Lowest suggested reading	% F.S.			0.05	
Lowest suggested control pressure	% F.S.			0.05	
Temperature Operation (ambient)	°C			+10 to +50	
Bakeout at flange	°C			≤110	
Storage	°C			-40 to +65	
Supply voltage				+14 to +30 VDC or ± 15 V (±5%)	
Power consumption during heat up	W			≤18	
Power consumption at operating temperatures	W			≤18	
Output signal (analog)	VDC			0 to +10	
Response time ²⁾	ms			30	
Degree of protection				IP 40	
Standards		EN 61000-6-2/6-3, EN 61010, UL 61010-1, CSA 22.2 No. 61010-1, SEMI S-2			
Electrical connection		D-sub, 15 pin, male			
Set point		two set points (SPT, SP2)			
Relay Contact	VDC / ADC	≤30 / ≤0.5			
Hysteresis	% F.S.	1			
Diagnostic port		RS232-C			
Protocol		Pressure, status, ID,			
Reed		set points, filter, zero adjust, factory reset, DC offset			
Set		Aluminum oxide ceramic (A203), stainless steel (AISI 316L ³⁾ , Nickel, sealing glass			
Materials exposed to vacuum					

¹⁾ Non-linearity, hysteresis, repeatability at 25°C ambient operating temperature without temperature effects after 2 hours operation.

²⁾ Incease 10 to 90% F.S.

³⁾ 18% Cr, 10% Ni, 3% Mo, 69% Fe



Downstream Pressure Control Accessories and Spare Parts



Power Supply APC-PSM-DB15

For use with all buried box DC powered APCs as well as IQ-series valves. 24 VDC, 2.5A power supply (100-240 VAC input). Includes CRD-PWR-US1 power cord and 6' (2m) DC supply cable with DB15 D-sub connector.



APC & IQ Valve
Power Supply

Diagram 1



Diagram 2



Diagram 3

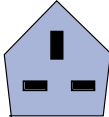
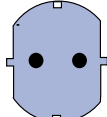

Diagram 4



AC Power Cord Plug
Configurations



Oldham
Coupling Hubs

To make the completion of an Intellisys downstream pressure control system easy, Nor-Cal Products offers a comprehensive selection of cables and related accessories. These include signal and communications cables, power cords, power supplies as well as spare parts.

Cable Nomenclature Clarification

Most cable and cord part numbers listed below end with the number 10 as a suffix, which represents the cable length, measured in feet. Thus, Nor-Cal's standard cable length is 10' (3m). However, any length between 1' (0.3m) and 30' (9.1m) can be supplied as a special request. Please contact Nor-Cal Products for price and availability information.

Cables and Power Cords

MODEL NUMBER	CABLE OR CORD TYPE	DESCRIPTION
TBV-CRD-10	Controller-to-Valve	Cable needed to connect any Intellisys throttle valve to any buried box controller. This cable is NOT needed for IQ-series valves.
CDG-CRD-10	Controller-to-Gauge	A/C powered APC-to-Gauge cable, where the gauge has screw terminals
CDG-CRD-DB9-10	Controller-to-Gauge	A/C powered APC-to-Gauge cable, where the gauge has a 9-pin D-sub connector
CDG-CRD-DB15-10	IQ Controller-to-Gauge	A/C powered APC-to-Gauge cable, where the gauge has a 15-pin D-sub connector. This is the correct cable to use for all Nor-Cal gauges.
CDG-IQ-CRD-10	IQ Controller-to-Gauge	DC powered (including all IQ models) APC-to-Gauge cable, where the gauge has screw terminals
CDG-IQ-CRD-DB9-10	IQ Controller-to-Gauge	DC powered (including all IQ models) APC-to-Gauge cable, where the gauge has a 9-pin D-sub connector
CDG-IQ-CRD-DB15-10	IQ Controller-to-Gauge	DC powered (including all IQ models) APC-to-Gauge cable, where the gauge has a 15-pin D-sub connector. This is the correct cable to use for all Nor-Cal gauges.
CDG-IQ-CRD-Y	IQ Controller-to-Gauge	A 1' (0.3m) long Y-cable to be used if two gauges are interfaced with a DC powered APC (including IQ). Use of this Y-cable also requires two extension cables. Use either CDG-CRD-10, CDG-IQ-CRD-DB9-10 or CDG-IQ-CRD-DB15-10.
APC-CRD-RS232-10	Serial Communication	Use to connect any AC powered APC to a standard PC or laptop DB-9 serial port.
IQ-CRD-RS232-10	Serial Communication	Same as above, but for use with DC powered APC models, including IQ.
RD-PWR-US1	AC Power Cord	7' (2m), 10A-125V rating. US standard power plug. See diagram 1.
CRD-PWR-US2	AC Power Cord	7' (2m), 10A-250V rating. US high voltage power plug. See diagram 2.
CRD-PWR-UK	AC Power Cord	7' (2m), 10A-250V rating. United Kingdom grounded power plug. See diagram 3.
CRD-PWR-EU	AC Power Cord	7' (2m), 10A-250V rating. Continental Europe grounded power plug. diagram 4.

APC Spare Parts

APC controllers do not contain any user serviceable parts except for replacement battery packs. All other service work needs to be performed by authorized Nor-Cal personnel. Please contact us for details.

MODEL NUMBER	SPARE PART	DESCRIPTION
APC-BAT-1518	Replacement battery pack	15-cell, 18-volt replacement battery pack
IQP-BAT-1518	IQ+ Replacement battery pack	15-cell, 18-volt replacement battery pack

TBV Spare Parts

PART NUMBER	SPARE PART	DESCRIPTION
54-310-004	Oldham Coupling Disk	Acetal. For all valves up to and including 4" (ISO-100)
54-330-006	Oldham Coupling Disk	Acetal. For 6 inch (ISO-160) valve and some UVD assemblies.
54-330-016	Oldham Coupling Disk	Acetal. For 8 inch (ISO-200) valve and some UVD assemblies
54-330-017	Oldham Coupling Disk	PEEK. For all valves up to and including 4" (ISO-100)
<i>Call for details</i>	Oldham Coupling Disk	PEEK. For 6 inch (ISO-160) valve and some UVD assemblies.
<i>Call for details</i>	Oldham Coupling Disk	PEEK. For 8 inch (ISO-200) valve and some UVD assemblies
TBV-400-90	Viton O-ring kit.	Set of four. For all TBV sizes up to and including 4" (ISO-100)
TBV-600-90	Viton O-ring kit.	Set of four. For 6 inch (ISO-160) TBV
TBV-800-90	Viton O-ring kit.	Set of four. For 8 inch (ISO-200) TBV and 10" (ISO-250) TBV

TPV and TSS Spare Parts

Please contact Nor-Cal Products technical support department for details.

CDG Spare Parts

CDG gauges do not contain any user serviceable parts. All service work needs to be performed by authorized Nor-Cal personnel. Please contact us for details.