

Liquid & Electrical Feedthroughs

Section Ten

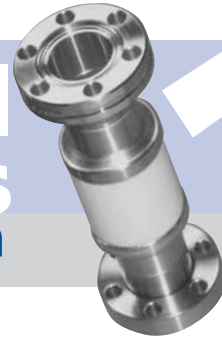

10



10.1	General Information	2
10.2	Liquid Feedthroughs	3
10.3	High Voltage Insulators	5
10.4	Electric Feedthroughs	6

Nor-Cal Products, Inc.
1967 South Oregon Street
Yreka, CA 96097 USA

Tel: **800-824-4166**
or 530-842-4457
Main Fax: 530-842-9130
Sales Fax: 530-841-9189
www.n-c.com



New Products

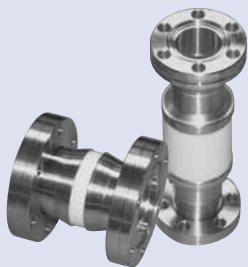

High Voltage Insulators

Vacuum insulators electrically isolate one component or system from another. Nor-Cal's ceramic insulators provide UHV compatible isolation. Our insulators are available in $\frac{3}{4}$ and $1\frac{1}{2}$ inch (19.05 and 38.1mm) tube diameters, 3KV to 15KV ratings, with either CF or NW flanges.



Liquid Feedthroughs

Nor-Cal's product line of liquid and liquid nitrogen feedthroughs includes the most commonly required for medium, high and ultrahigh vacuum applications. Tubing is .25 and .375 (6.35 and 9.53mm) inch OD, 304 stainless steel with CF or NW flanges. They are available without fittings or terminated with industry standard Swagelok or Cajon VCR fittings. Maximum bakeout with CF flanges is 450°C and 200°C with NWs. Vacuum ranges are 10^{-10} mbar and 10^{-8} , respectively.

Liquid feedthroughs are a cost-effective and reliable way to introduce water into a vacuum system. The .035 inch (.89mm) single wall tube construction is designed for the transport of water as a cooling agent.

Liquid nitrogen feedthroughs are constructed with single and dual coaxial tube geometries. This thermal barrier effectively reduces condensation and ice buildup on the atmosphere side of the feedthrough around the mounting flange interface, protecting the seal's integrity. This is necessary because of the extreme thermal gradients encountered with liquid nitrogen.

Swagelok stainless steel tube compression fittings provide a leakproof, torque-free vacuum seal by swaging the stainless steel tube to which they are mated. These fittings require no gaskets.

Cajon VCR stainless steel compression fittings provide a quick and efficient means of vacuum system assembly. These zero clearance fittings make them the perfect installation solution when space is limited. Compression of a removable copper gasket creates a vacuum seal between the air and process sides.

Electrical Feedthroughs

Nor-Cal's extensive line of electrical feedthroughs are manufactured from ultra-high vacuum grade materials such as high alumina ceramic insulators, OFHC copper or nickel conductors, and 304 stainless steel flanges. These robust ceramic to metal feedthroughs have electrical ratings for operation with one side in dry atmosphere while the opposite end is in a stable vacuum. They are used in UHV systems with CF flanges or high vacuum systems with NW flanges. CF feedthroughs can be baked to 450°C and NWs to 200°C. Our product line consists of the most commonly required feedthroughs for general vacuum applications. Custom designs or modified standards can readily be supplied.

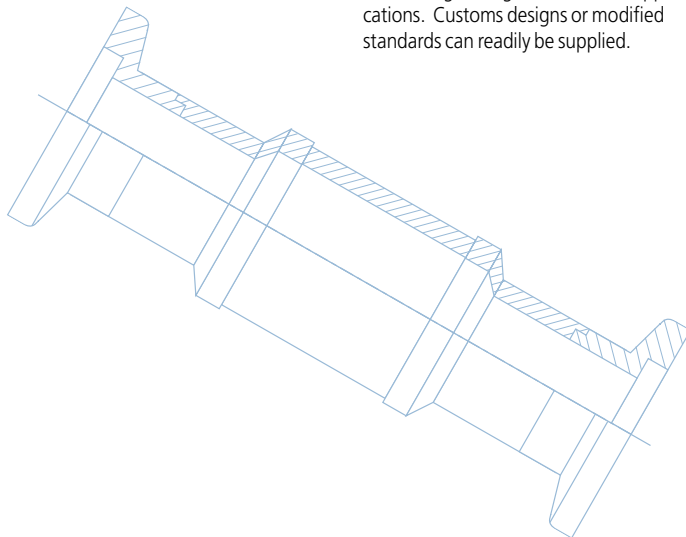

All dimensions are in inches (mm) & weights are in pounds (kg), unless otherwise noted.

Single Liquid Feedthroughs

MODEL NUMBER	FLANGE	TUBE FITTINGS	TUBE OD	A	B
LFT-NW-16-1-025	NW-16	None	0.250 (6.35)	3.00 (76.20)	4.00 (101.60)
LFT-NW-25-1-025	NW-25	None	0.250 (6.35)	3.00 (76.20)	4.00 (101.60)
LFT-NW-25-1-025-2SW	NW-25	2 Swagelok	0.250 (6.35)	4.01 (101.85)	5.01 (127.25)
LFT-NW-25-1-025-2MVCR	NW-25	2 MVCR	0.250 (6.35)	4.03 (102.36)	5.03 (127.76)
LFT-NW-40-1-025	NW-40	None	0.250 (6.35)	3.00 (76.20)	4.00 (101.60)
LFT-NW-40-1-025-2SW	NW-40	2 Swagelok	0.250 (6.35)	4.01 (101.85)	5.01 (127.25)
LFT-NW-40-1-025-2MVCR	NW-40	2 MVCR	0.250 (6.35)	4.03 (102.36)	5.03 (127.76)
LFT-NW-40-1-038	NW-40	None	0.375 (9.53)	3.00 (76.20)	4.00 (101.60)
LFT-NW-50-1-025	NW-50	None	0.250 (6.35)	3.00 (76.20)	4.00 (101.60)
LFT-NW-50-1-025-2SW	NW-50	2 Swagelok	0.250 (6.35)	4.01 (101.85)	5.01 (127.25)
LFT-NW-50-1-025-2MVCR	NW-50	2 MVCR	0.250 (6.35)	4.03 (102.36)	5.03 (127.76)
LFT-NW-50-1-038	NW-50	None	0.375 (9.53)	3.00 (76.20)	4.00 (101.60)
LFT-075-1-025	1.33 CF	None	0.250 (6.35)	3.00 (76.20)	4.00 (101.60)
LFT-075-1-038	2.75 CF	None	0.375 (9.53)	3.00 (76.20)	4.00 (101.60)
LFT-150-1-025	2.75 CF	None	0.250 (6.35)	3.00 (76.20)	4.00 (101.60)
LFT-150-1-025-2SW	2.75 CF	2 Swagelok	0.250 (6.35)	4.01 (101.85)	5.01 (127.25)
LFT-150-1-025-2MVCR	2.75 CF	2 MVCR	0.250 (6.35)	4.03 (102.36)	5.03 (127.76)
LFT-150-1-038	2.75 CF	None	0.375 (9.53)	3.00 (76.20)	4.00 (101.60)

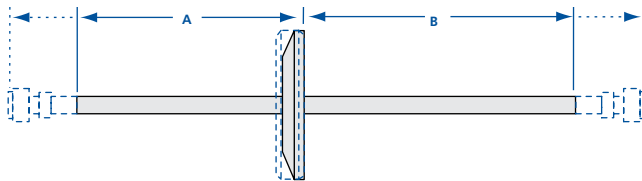

SPECIFICATIONS

Materials

Flange: 304 stainless steel

Vacuum range

Metal seal: $\geq 10^{-10}$ mbar (UHV)

Elastomer seal: $\geq 10^{-8}$ mbar (High vacuum)

Temperature range

Metal seal: -270°C to 450°C

Elastomer seal: -20°C to 200°C

Dual Liquid Feedthroughs

MODEL NUMBER	FLANGE	TUBE FITTINGS	TUBE OD	A	B
LFT-NW-40-2-025	NW-40	None	0.250 (6.35)	3.00 (76.20)	4.00 (101.60)
LFT-NW-40-2-025-4SW	NW-40	4 Swagelok	0.250 (6.35)	4.01 (101.85)	5.01 (127.25)
LFT-NW-40-2-025-4MVCR	NW-40	4 MVCR	0.250 (6.35)	4.03 (102.36)	5.03 (127.76)
LFT-NW-50-2-025	NW-50	None	0.250 (6.35)	3.00 (76.20)	4.00 (101.60)
LFT-NW-50-2-025-4SW	NW-50	4 Swagelok	0.250 (6.35)	4.01 (101.85)	5.01 (127.25)
LFT-NW-50-2-025-4MVCR	NW-50	4 MVCR	0.250 (6.35)	4.03 (102.36)	5.03 (127.76)
LFT-150-2-025	2.75 CF	None	0.250 (6.35)	3.00 (76.20)	4.00 (101.60)
LFT-150-2-025-4SW	2.75 CF	4 Swagelok	0.250 (6.35)	4.01 (101.85)	5.01 (127.25)
LFT-150-2-025-4MVCR	2.75 CF	4 MVCR	0.250 (6.35)	4.03 (102.36)	5.03 (127.76)
LFT-150-2-038	2.75 CF	None	0.375 (9.53)	3.00 (76.20)	4.00 (101.60)

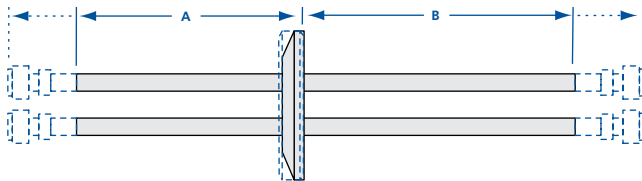

SPECIFICATIONS

Materials

Flange: 304 stainless steel

Vacuum range

Metal seal: $\geq 10^{-10}$ mbar (UHV)

Elastomer seal: $\geq 10^{-8}$ mbar (High vacuum)

Temperature range

Metal seal: -270°C to 450°C

Elastomer seal: -20°C to 200°C

All dimensions for optional fittings are referenced from the seal face

All dimensions are in inches (mm) & weights are in pounds (kg), unless otherwise noted.





Single Liquid Nitrogen Feedthroughs

SPECIFICATIONS

Materials

Flange: 304 stainless steel

Vacuum range

Metal seal: $\geq 10^{-10}$ mbar (UHV)

Elastomer seal: $\geq 10^{-8}$ mbar (High vacuum)

Temperature range

Metal seal: -270°C to 450°C

Elastomer seal: -20°C to 200°C

MODEL NUMBER	FLANGE	TUBE FITTINGS	TUBE OD	A	B
LNF-NW-16-1-025	NW-16	None	0.250 (6.35)	5.50 (139.70)	4.50 (114.30)
LNF-NW-25-1-025	NW-25	None	0.250 (6.35)	5.50 (139.70)	4.50 (114.30)
LNF-NW-25-1-025-2SW	NW-25	2 Swagelok	0.250 (6.35)	6.51 (165.35)	5.51 (139.95)
LNF-NW-25-1-025-2MVCR	NW-25	2 MVCR	0.250 (6.35)	6.53 (165.86)	5.53 (140.46)
LNF-NW-40-1-025	NW-40	None	0.250 (6.35)	5.50 (139.70)	4.50 (114.30)
LNF-NW-40-1-025-2SW	NW-40	2 Swagelok	0.250 (6.35)	6.51 (165.35)	5.51 (139.95)
LNF-NW-40-1-025-2MVCR	NW-40	2 MVCR	0.250 (6.35)	6.53 (165.86)	5.53 (140.46)
LNF-NW-40-1-038	NW-40	None	0.375 (9.53)	5.50 (139.70)	4.50 (114.30)
LNF-NW-50-1-025	NW-50	None	0.250 (6.35)	5.50 (139.70)	4.50 (114.30)
LNF-NW-50-1-025-2SW	NW-50	2 Swagelok	0.250 (6.35)	6.51 (165.35)	5.51 (139.95)
LNF-NW-50-1-025-2MVCR	NW-50	2 MVCR	0.250 (6.35)	6.53 (165.86)	5.53 (140.46)
LNF-NW-50-1-038	NW-50	None	0.375 (9.53)	5.50 (139.70)	4.50 (114.30)
LNF-075-1-025	1.33 CF	None	0.250 (6.35)	5.50 (139.70)	4.50 (114.30)
LNF-075-1-038	1.33 CF	None	0.375 (9.53)	5.50 (139.70)	4.50 (114.30)
LNF-150-1-025	2.75 CF	None	0.250 (6.35)	5.50 (139.70)	4.50 (114.30)
LNF-150-1-025-2SW	2.75 CF	2 Swagelok	0.250 (6.35)	6.51 (165.35)	5.51 (139.95)
LNF-150-1-025-2MVCR	2.75 CF	2 MVCR	0.250 (6.35)	6.53 (165.86)	5.53 (140.46)
LNF-150-1-038	2.75 CF	None	0.375 (9.53)	5.50 (139.70)	4.50 (114.30)

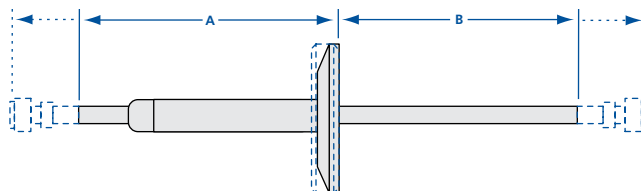

Dual Liquid Nitrogen Feedthroughs

SPECIFICATIONS

Materials

Flange: 304 stainless steel

Vacuum range

Metal seal: $\geq 10^{-10}$ mbar (UHV)

Elastomer seal: $\geq 10^{-8}$ mbar (High vacuum)

Temperature range

Metal seal: -270°C to 450°C

Elastomer seal: -20°C to 200°C

MODE NUMBER	FLANGE	TUBE FITTINGS	TUBE	A	B	C	D
LNF-NW-40-2-025	NW-40	None	0.250 (6.35)	6.50 (165.10)	3.50 (88.90)	5.50 (139.70)	4.50 (114.30)
LNF-NW-40-2-025-4SW	NW-40	4 Swagelok	0.250 (6.35)	7.51 (190.75)	4.51 (114.55)	6.51 (165.35)	5.51 (139.95)
LNF-NW-40-2-025-4MVCR	NW-40	4 MVCR	0.250 (6.35)	7.53 (191.26)	4.53 (115.06)	6.53 (165.86)	5.53 (140.46)
LNF-NW-50-2-025	NW-50	None	0.250 (6.35)	6.50 (165.10)	3.50 (88.90)	5.50 (139.70)	4.50 (114.30)
LNF-NW-50-2-025-4SW	NW-50	4 Swagelok	0.250 (6.35)	7.51 (190.75)	4.51 (114.55)	6.51 (165.35)	5.51 (139.95)
LNF-NW-50-2-025-4MVCR	NW-50	4 MVCR	0.250 (6.35)	7.53 (191.26)	4.53 (115.06)	6.53 (165.86)	5.53 (140.46)
LNF-150-2-025	2.75 CF	None	0.250 (6.35)	6.50 (165.10)	3.50 (88.90)	5.50 (139.70)	4.50 (114.30)
LNF-150-2-025-4SW	2.75 CF	4 Swagelok	0.250 (6.35)	7.51 (190.75)	4.51 (114.55)	6.51 (165.35)	5.51 (139.95)
LNF-150-2-025-4MVCR	2.75 CF	4 MVCR	0.250 (6.35)	7.53 (191.26)	4.53 (115.06)	6.53 (165.86)	5.53 (140.46)
LNF-150-2-038	2.75 CF	None	0.375 (9.53)	6.50 (165.10)	3.50 (88.90)	5.50 (139.70)	4.50 (114.30)

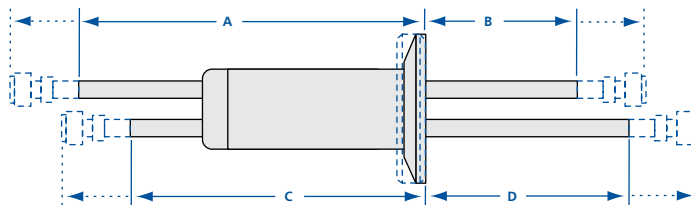

All dimensions for optional fittings are referenced from the seal face

All dimensions are in inches (mm) & weights are in pounds (kg), unless otherwise noted.

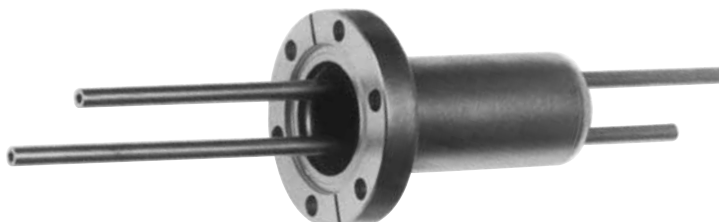



Vacuum insulators (also known as vacuum breaks and isolators) are used to electrically isolate one component or system from another. Nor-Cal uses a ceramic insulator with 95% minimum aluminum oxide content, which is silver brazed to two Kovar sleeves, creating a UHV compatible insulator. The insulator is then welded to the appropriate vacuum flange. Standard vacuum insulators are available in two tube diameters, 3/4 and 1 1/2 inches (19.05 and 38.1mm). The 3/4 inch (19.05mm) size is rated up to 10KV, while the 1 1/2 inch (38.1mm) size is offered in two voltage ratings (3KV and 15KV). All three voltage ratings are available with either two NW (ISO-KF) flanges for high vacuum applications or with one non-rotatable and rotatable CF (Conflat) flange for ultra-high vacuum applications. Other sizes, current ratings and flange combinations are available on request.

SPECIFICATIONS

Materials

Flanges: 304 stainless steel
 Sleeve: Kovar
 Insulator: Ceramic
 (95% aluminum oxide content)
 Magnetic: Yes

Vacuum range

Metal seal: $\geq 10^{-13}$ mbar (UHV)
 Elastomer seal: $\geq 10^{-8}$ mbar (High vacuum)

Temperature range

Metal seal: $\leq 450^\circ\text{C}$
 Elastomer seal: $\leq 150^\circ\text{C}$ sustained,
 $\leq 200^\circ\text{C}$ intermittent
 Gradient: $25^\circ\text{C}/\text{minute}$ maximum

CF High Voltage Insulators

MODEL NUMBER	TUBE OD	MAX. VOLTAGE (KV)	A	B	C	D	E	F
HVI-075-10	3/4 (19.05)	10	3.62 (91.95)	1.00 (25.40)	0.63 (16.00)	1.33 (33.78)	1.04 (26.42)	0.75 (19.05)
HVI-150-3	1 1/2 (38.10)	3	2.65 (67.31)	0.25 (6.35)	1.37 (34.80)	2.73 (69.34)	1.66 (42.16)	1.25 (31.75)
HVI-150-15	1 1/2 (38.10)	15	4.20 (106.68)	2.00 (50.80)	1.37 (34.80)	2.73 (69.34)	1.66 (42.16)	1.25 (31.75)

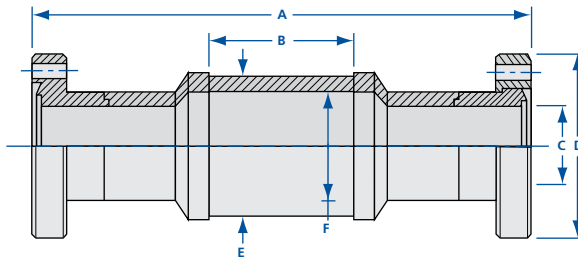

NW High Voltage Insulators

MODEL NUMBER	TUBE OD	MAX. VOLTAGE (KV)	A	B	C	D	E	F
HVI-NW-16-10	3/4 (19.05)	10	3.62 (91.95)	1.00 (25.40)	0.63 (16.00)	1.18 (29.97)	1.04 (26.42)	0.75 (19.05)
HVI-NW-40-3	1 1/2 (38.10)	3	2.28 (57.91)	0.25 (6.35)	1.37 (34.80)	2.16 (54.86)	1.66 (42.16)	1.25 (31.75)
HVI-NW-40-15	1 1/2 (38.10)	15	4.03 (102.36)	2.00 (50.8)	1.37 (34.80)	2.16 (54.86)	1.66 (42.16)	1.25 (31.75)

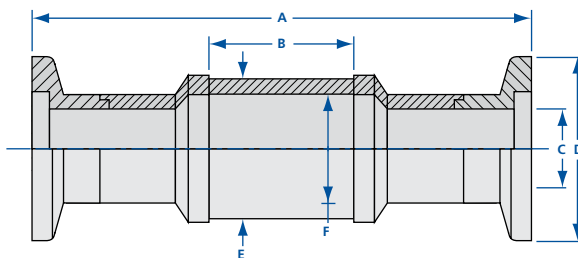

All dimensions are in inches (mm) & weights are in pounds (kg), unless otherwise noted.



Medium Current Copper Feedthroughs

These electrical feedthroughs transmit either high voltage, high current or a combination of both. They are used for sample heating, in-vacuum coating, electron beam evaporation, sputtering and other high vacuum applications. High-purity, high-strength, low-loss alumina ceramic surfaces maximize strike and creep distances. The air-side ceramic surfaces have a high temperature glass coating which reduces surface roughness and contamination.

SPECIFICATIONS

Materials

Flange: 304 stainless steel
Conductors: OFHC copper
Insulator: Alumina ceramic

Electrical

Voltage: 5 KVDC
Current: 150 Amps

Connector: Use with vacuum connector
MCF-VC (see page 216)

Vacuum range

Metal seal: $\geq 10^{-10}$ mbar (UHV)
Elastomer seal: $\geq 10^{-8}$ mbar (High vacuum)

Temperature range

Metal seal: -270°C to 450°C
Elastomer seal: -20°C to 200°C

MODEL NUMBER	FLANGE	NUMBER OF FEEDTHROUGHS	A	B
MCF-NW-16-1	NW-16	1	3.23 (82.04)	4.03 (102.36)
MCF-NW-25-1	NW-25	1	3.23 (82.04)	4.03 (102.36)
MCF-NW-40-1	NW-40	1	3.13 (79.50)	4.13 (104.90)
MCF-NW-40-2	NW-40	2	3.23 (82.04)	4.03 (102.36)
MCF-NW-40-3	NW-40	3	3.23 (82.04)	4.03 (102.36)
MCF-NW-40-4	NW-40	4	3.23 (82.04)	4.03 (102.36)
MCF-NW-50-1	NW-50	1	3.13 (79.50)	4.13 (104.90)
MCF-NW-50-2	NW-50	2	3.23 (82.04)	4.03 (102.36)
MCF-NW-50-3	NW-50	3	3.23 (82.04)	4.03 (102.36)
MCF-NW-50-4	NW-50	4	3.23 (82.04)	4.03 (102.36)
MCF-075-1	1.33 CF	1	3.21 (81.53)	4.05 (102.87)
MCF-150-1	2.75 CF	1	3.18 (80.77)	4.08 (103.63)
MCF-150-2	2.75 CF	2	3.18 (80.77)	4.08 (103.63)
MCF-150-3	2.75 CF	3	3.18 (80.77)	4.08 (103.63)
MCF-150-4	2.75 CF	4	3.18 (80.77)	4.08 (103.63)

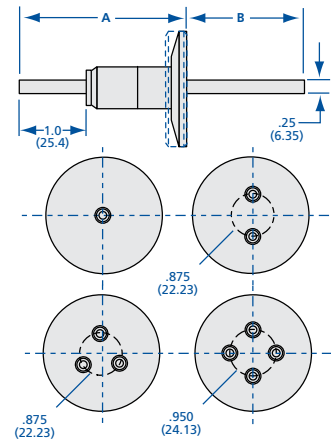

Medium Current Nickel Feedthroughs

The nickel rod conductors on these electrical feedthroughs offer an alternative to copper for use in environments and processes that attack copper surfaces.

SPECIFICATIONS

Materials

Flange: 304 stainless steel
Conductors: Nickel rod
Insulator: Alumina ceramic

Electrical

Voltage: 12 KVDC
Current: 56 Amps

Connector: Use with vacuum connector
MCF-VC (see page 216)

Vacuum range

Metal seal: $\geq 10^{-10}$ mbar (UHV)
Elastomer seal: $\geq 10^{-8}$ mbar (High vacuum)

Temperature range

Metal seal: -270°C to 450°C
Elastomer seal: -20°C to 200°C

MODEL NUMBER	FLANGE	NUMBER OF FEEDTHROUGHS	A	B
MCF-NW-16-1N	NW-16	1	3.23 (82.04)	4.03 (102.36)
MCF-NW-25-1N	NW-25	1	3.23 (82.04)	4.03 (102.36)
MCF-NW-40-1N	NW-40	1	3.13 (79.50)	4.13 (104.90)
MCF-NW-40-2N	NW-40	2	3.23 (82.04)	4.03 (102.36)
MCF-NW-40-3N	NW-40	3	3.23 (82.04)	4.03 (102.36)
MCF-NW-40-4N	NW-40	4	3.23 (82.04)	4.03 (102.36)
MCF-NW-50-1N	NW-50	1	3.13 (79.50)	4.13 (104.90)
MCF-NW-50-2N	NW-50	2	3.23 (82.04)	4.03 (102.36)
MCF-NW-50-3N	NW-50	3	3.23 (82.04)	4.03 (102.36)
MCF-NW-50-4N	NW-50	4	3.23 (82.04)	4.03 (102.36)
MCF-075-1N	1.33 CF	1	3.21 (81.53)	4.05 (102.87)
MCF-150-1N	2.75 CF	1	3.18 (80.77)	4.08 (103.63)
MCF-150-2N	2.75 CF	2	3.18 (80.77)	4.08 (103.63)
MCF-150-3N	2.75 CF	3	3.18 (80.77)	4.08 (103.63)
MCF-150-4N	2.75 CF	4	3.18 (80.77)	4.08 (103.63)

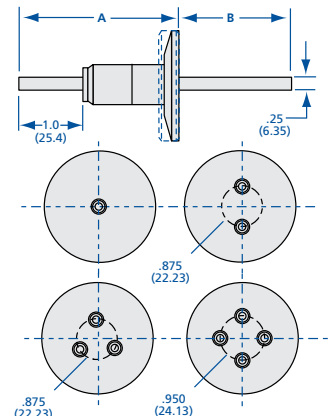

Water Cooled Medium Current Copper Feedthroughs

These water cooled electrical feedthroughs transmit power and coolants simultaneously. They conduct higher current loads than solid rod conductors of equal size when properly cooled. Grounding of system is necessary for safety.

SPECIFICATIONS

Materials

Flange: 304 stainless steel
Conductors: OFHC copper tube
Insulator: Alumina ceramic

Electrical

Voltage: 12 KVDC

Vacuum range

Metal seal: $\geq 10^{-10}$ mbar (UHV)
Elastomer seal: $\geq 10^{-8}$ mbar (High vacuum)

Temperature range

Metal seal: -270°C to 450°C
Elastomer seal: -20°C to 200°C

MODEL NUMBER	FLANGE	NUMBER OF FEEDTHROUGHS	A	B
MCF-NW-16-1W	NW-16	1	3.23 (82.04)	4.03 (102.36)
MCF-NW-25-1W	NW-25	1	3.23 (82.04)	4.03 (102.36)
MCF-NW-40-1W	NW-40	1	3.13 (79.50)	4.13 (104.90)
MCF-NW-40-2W	NW-40	2	3.23 (82.04)	4.03 (102.36)
MCF-NW-40-3W	NW-40	3	3.23 (82.04)	4.03 (102.36)
MCF-NW-40-4W	NW-40	4	3.23 (82.04)	4.03 (102.36)
MCF-NW-50-1W	NW-50	1	3.13 (79.50)	4.13 (104.90)
MCF-NW-50-2W	NW-50	2	3.23 (82.04)	4.03 (102.36)
MCF-NW-50-3W	NW-50	3	3.23 (82.04)	4.03 (102.36)
MCF-NW-50-4W	NW-50	4	3.23 (82.04)	4.03 (102.36)
MCF-075-1W	1.33 CF	1	3.21 (81.53)	4.05 (102.87)
MCF-150-1W	2.75 CF	1	3.18 (80.77)	4.08 (103.63)
MCF-150-2W	2.75 CF	2	3.18 (80.77)	4.08 (103.63)
MCF-150-3W	2.75 CF	3	3.18 (80.77)	4.08 (103.63)
MCF-150-4W	2.75 CF	4	3.18 (80.77)	4.08 (103.63)

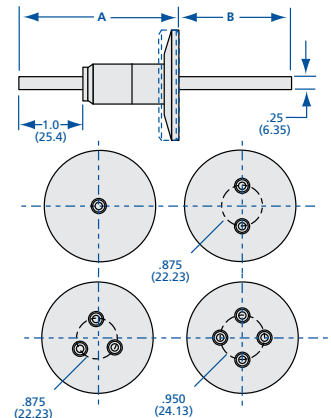

All dimensions are in inches (mm) & weights are in pounds (kg), unless otherwise noted.

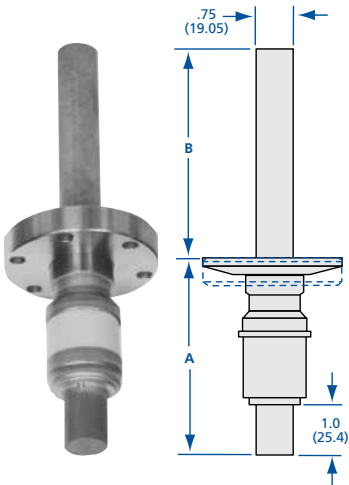

Single High Current Copper Feedthroughs

These electrical power feedthroughs accommodate a higher electrical current due to the size of the copper rod.

MODEL NUMBER	FLANGE	CURRENT	A	B
HCF-NW-40-1	NW-40	600 Amps	3.85 (97.79)	3.40 (86.36)
HCF-NW-50-1	NW-50	600 Amps	3.85 (97.79)	3.40 (86.36)
HCF-150-1	2.75 CF	600 Amps	3.90 (99.06)	3.35 (85.09)

Single Water Cooled High Current Copper Feedthroughs

MODEL NUMBER	FLANGE	A	B
HCF-NW-40-1W	NW-40	3.85 (97.79)	3.40 (86.36)
HCF-NW-50-1W	NW-50	8.85 (224.79)	3.40 (86.36)
HCF-150-1W	2.75 CF	3.90 (99.06)	3.35 (85.09)

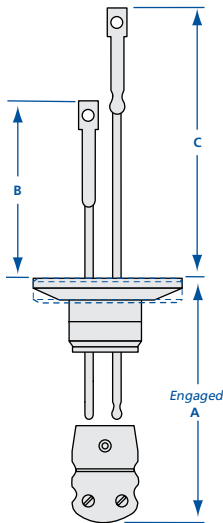

Thermocouple Feedthroughs

Thermocouple feedthroughs carry instrumentation signals while providing electrical isolation and hermetic sealing. They are leak free in high and ultra high vacuum environments and are composed of only inorganic materials. The insulators are made of high purity, high strength, low-loss alumina ceramic.

MODEL NUMBER	FLANGE	A	B	C
TC-NW-16-1	NW-16	2.40 (60.96)	3.00 (76.20)	4.00 (101.60)
TC-NW-25-1	NW-25	2.02 (51.31)	3.38 (85.85)	4.38 (111.25)
TC-NW-40-1	NW-40	1.90 (48.26)	3.50 (88.90)	4.50 (114.30)
TC-NW-50-1	NW-50	1.90 (48.26)	3.50 (88.90)	4.50 (114.30)
TC-075-1	1.33 CF	2.40 (60.96)	3.00 (76.20)	4.00 (101.60)
TC-150-1	2.75 CF	1.95 (49.53)	3.45 (87.63)	4.45 (113.03)

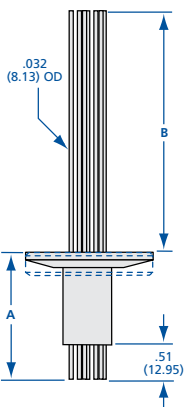

8-Pin Instrumentation Feedthroughs

Multipin instrumentation feedthroughs are typically used to transmit signal voltages and currents. Applications such as electron beam evaporation, electron microscopy and surface science analysis utilize these feedthroughs to control processes.

MODEL NUMBER	FLANGE	A	B
IFT-NW-16-8P	NW-16	1.32 (33.53)	1.18 (29.97)
IFT-NW-25-8P	NW-25	0.92 (23.37)	1.58 (40.13)
IFT-NW-40-8P	NW-40	0.82 (20.83)	1.68 (42.67)
IFT-NW-50-8P	NW-50	0.82 (20.83)	1.68 (42.67)
IFT-075-8P	1.33 CF	1.32 (33.53)	1.18 (29.97)
IFT-150-8P	2.75 CF	0.87 (22.10)	1.63 (41.40)

SPECIFICATIONS

Materials
 Flange: 304 stainless steel
 Conductors: OFHC copper
 Insulator: Alumina ceramic

Electrical
 Voltage: 3 KVDC peak

Vacuum Range
 Metal Seal: $\geq 10^{-10}$ mbar (UHV)
 Elastomer Seal: $\geq 10^{-8}$ mbar (High vacuum)

Temperature Range
 Metal seal: -270°C to 450°C
 Elastomer seal: -20°C to 200°C

SPECIFICATIONS

Materials
 Flange: 304 stainless steel
 Conductors: Chromel/Alumel
 Insulator: Alumina ceramic

Connectors
 Plug color: Yellow
 Thermocouple: Type K

Included hardware: Plugs, screws and nuts for vacuum and atmosphere lead attachment

Vacuum range
 Metal seal: $\geq 10^{-10}$ mbar (UHV)
 Elastomer seal: $\geq 10^{-8}$ mbar (High vacuum)

Temperature range
 Metal seal: -270°C to 450°C
 (plug disconnected)
 Elastomer seal: -20°C to 150°C

SPECIFICATIONS

Materials
 Flange: 304 stainless steel
 Conductors: 0.032 OD nickel wire
 Insulator: Alumina ceramic

Electrical
 Voltage: 500 VDC
 Current: 2 Amps

Connector: Use with vacuum connector IFT-VC (see page 216)

Vacuum range
 Metal seal: $\geq 10^{-10}$ mbar (UHV)
 Elastomer seal: $\geq 10^{-8}$ mbar (High vacuum)

Temperature range
 Metal seal: -270°C to 450°C
 Elastomer seal: -20°C to 200°C



BNC Coaxial Feedthroughs

The BNC (Bayonet Naval Connection) electrical feedthrough consists of two concentric conductor paths which are separated and insulated with high-purity alumina ceramic. It is commonly used in 50 to 70 ohm low power instrumentation lines.

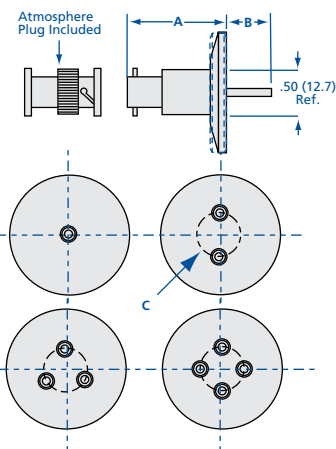

SPECIFICATIONS

Materials	Flange: 304 stainless steel Conductors: Stainless steel Insulator: Alumina ceramic
Electrical	Voltage: 500 VDC @10 ⁻⁴ mbar Current: 3 Amps
Connector:	Use with vacuum connector BNC-VC (see below), atmosphere connector included
Vacuum range	Metal seal: ≥10 ⁻¹⁰ mbar (UHV) Elastomer seal: ≥10 ⁻⁸ mbar (High vacuum)
Temperature range	Metal seal: -270°C to 450°C Elastomer seal: -20°C to 200°C

MODEL NUMBER	FLANGE	NUMBER OF FEEDTHROUGHS	A	B	C
BNC-NW-16-1	NW-16	1	1.43 (36.32)	0.32 (8.13)	-
BNC-NW-25-1	NW-25	1	1.43 (36.32)	0.32 (8.13)	-
BNC-NW-40-1	NW-40	1	1.33 (33.78)	0.42 (10.67)	-
BNC-NW-40-2	NW-40	2	1.33 (33.78)	0.42 (10.67)	0.75 (19.05)
BNC-NW-40-3	NW-40	3	1.33 (33.78)	0.42 (10.67)	0.75 (19.05)
BNC-NW-40-4	NW-40	4	1.43 (36.32)	0.32 (8.13)	0.90 (22.86)
BNC-NW-50-1	NW-50	1	1.33 (33.78)	0.42 (10.67)	-
BNC-NW-50-2	NW-50	2	1.33 (33.78)	0.42 (10.67)	0.75 (19.05)
BNC-NW-50-3	NW-50	3	1.33 (33.78)	0.42 (10.67)	0.75 (19.05)
BNC-NW-50-4	NW-50	4	1.33 (33.78)	0.42 (10.67)	0.90 (22.86)
BNC-075-1	1.33 CF	1	1.41 (35.81)	0.34 (8.640)	-
BNC-150-1	2.75 CF	1	1.38 (35.05)	0.37 (9.40)	-
BNC-150-2	2.75 CF	2	1.38 (35.05)	0.37 (9.40)	0.95 (24.13)
BNC-150-3	2.75 CF	3	1.38 (35.05)	0.37 (9.40)	0.95 (24.13)
BNC-150-4	2.75 CF	4	1.38 (35.05)	0.37 (9.40)	0.95 (24.13)

MHV Coaxial Feedthroughs

The MHV (Miniature High Voltage or High Voltage BNC) electrical feedthroughs operate in medium to high power with higher voltage requirements. MHV and BNC feedthroughs look similar but are very different in electrical rating. They should never be cross-mated since their electrical ratings are not compatible.

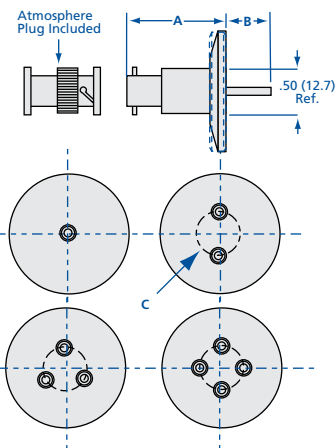

SPECIFICATIONS

Materials	Flange: 304 stainless steel Conductors: Stainless steel Insulator: Alumina ceramic
Electrical	Voltage: 5 KV Current: 3 Amps
Connector:	Use with vacuum connector MCF-VC (see below), atmosphere connector included
Vacuum range	Metal seal: ≥10 ⁻¹⁰ mbar (UHV) Elastomer seal: ≥10 ⁻⁸ mbar (High vacuum)
Temperature range	Metal seal: -270°C to 450°C Elastomer seal: -20°C to 200°C

MODEL NUMBER	FLANGE	NUMBER OF FEEDTHROUGHS	A	B	C
MHV-NW-16-1	NW-16	1	1.43 (36.32)	0.25 (6.35)	-
MHV-NW-25-1	NW-25	1	1.43 (36.32)	0.25 (6.25)	-
MHV-NW-40-1	NW-40	1	1.33 (33.78)	0.35 (8.89)	-
MHV-NW-40-2	NW-40	2	1.33 (33.78)	0.35 (8.89)	0.75 (19.05)
MHV-NW-40-3	NW-40	3	1.33 (33.78)	0.35 (8.89)	0.75 (19.05)
MHV-NW-40-4	NW-40	4	1.43 (36.32)	0.25 (6.35)	0.90 (22.86)
MHV-NW-50-1	NW-50	1	1.33 (33.78)	0.35 (8.89)	-
MHV-NW-50-2	NW-50	2	1.33 (33.78)	0.35 (8.89)	0.75 (19.05)
MHV-NW-50-3	NW-50	3	1.33 (33.78)	0.35 (8.89)	0.75 (19.05)
MHV-NW-50-4	NW-50	4	1.33 (33.78)	0.35 (8.89)	0.90 (22.86)
MHV-075-1	1.33 CF	1	1.41 (35.81)	0.27 (6.86)	-
MHV-150-1	2.75 CF	1	1.38 (35.05)	0.30 (7.62)	-
MHV-150-2	2.75 CF	2	1.38 (35.05)	0.30 (7.62)	0.95 (24.13)
MHV-150-3	2.75 CF	3	1.38 (35.05)	0.30 (7.62)	0.95 (24.13)
MHV-150-4	2.75 CF	4	1.38 (35.05)	0.30 (7.62)	0.95 (24.13)

Electrical Feedthrough Connectors

MODEL NUMBER	USE WITH	MATERIAL	MAXIMUM CURRENT (AMPS)	QUANTITY
MCF-VC	Medium Current	Beryllium Copper with SS Screws	100	10 per Pkg.
BNC-VC	BNC and MHV	Beryllium Copper with SS Screws	15	10 per Pkg.
IFT-VC	8-Pin Instrumentation	Beryllium Copper	10	10 per Pkg.

