

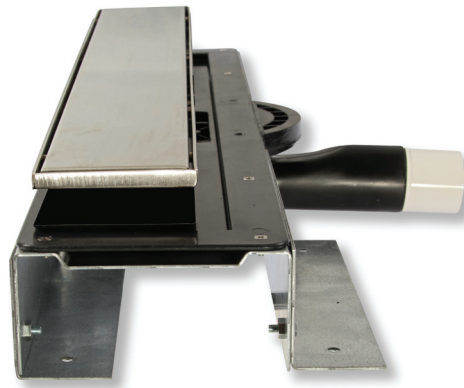

SECTION 1.2 LINEAR WALL DRAIN



PRODUCT SPECIFICATION GUIDE

I.2 LINEAR WALL DRAIN

FINISHED PRODUCT



The Linear Wall Drain is a development of our popular Linear Screed Drain and has been designed with the grill positioned flush against the wall, giving a sleek and unobtrusive finish.

It is designed for concrete or screeded floors with the key feature being its height - the total height from the base to the top of the trough being

only 67mm, making it perfect for today's modern construction methods.

The drain incorporates a unique waterless trap which has a lifetime guarantee and has been granted BBA approval. It is available with one, two or three traps and a choice of stylish grill finishes.

KEY FEATURES

- Overall height 67mm (min) including trap
- BBA approved
- Lifetime Guarantee
- Variable waste position
- Waterless trap
- Flow rate up to 70 L/min
- Grill height and width adjustable
- Easy to clean and replace trap
- Bespoke design available



1.2 LINEAR WALL DRAIN

WATERLESS TRAP

The waterless trap has been specially designed with a spring loaded mechanism which keeps the trap sealed when not in use.

This ensures that even when left unused for prolonged periods the trap cannot dry out, making it ideal for situations where the shower is not in everyday use.

The smart design of the linear trough allows the waste position to be varied, enabling installation in most scenarios with ease.



- BBA approved
- 360° rotatable waste position
- Easy to clean and replace trap
- No requirement to top up the trap during long periods of non-use
- No siphoning of the trap due to other appliances
- No chance of smells or gases entering the room

NO. OF TRAPS

A single trapped Linear Wall Drain has a flow rate of up to 29 L/min* with the support brackets on either side.

When a higher flow rate is required a double trap version is available, allowing up to 57 L/min*. The traps are positioned near each end of the trough with a single support bracket in the centre.

For higher flow rates, a triple trapped drain is also available with support brackets at either end.

* See flow rate chart for full details



No. of traps	No. of wastes		
	1	2	3
1	29 L/min	n/a	n/a
2	41 L/min	50 L/min	n/a
3	50 L/min	50 L/min	50 L/min
1	29 L/min	n/a	n/a
2	45 L/min	57 L/min	n/a
3	54 L/min	58 L/min	70 L/min

Stone / Solid-infill
Slotted / Square Holes

1.2 LINEAR WALL DRAIN

GRILL LENGTH

All Linear Wall Drains are manufactured with one trough size at 660mm, all lengths of grill are then fitted onto this trough.

Bespoke grills can be manufactured for sizes in between and over those that are standard, please contact our technical team to discuss your requirements.

The Linear Wall Drain is available in four standard sizes;

- 600mm
- 800mm
- 900mm
- 1000mm
- 1100mm
- 1200mm
- 1300mm
- 1400mm
- 1500mm

Grill Width: 86mm

9 GRILL LENGTHS



GRILL FINISH

The grill is available in various different finishes.

All are manufactured in 316 marine grade stainless steel, ensuring a stunning high quality finish.

Type A - Solid Grill is supplied as standard unless otherwise specified.

Type A - Solid Grill:
Grained stainless steel with a 3mm gap around the grill for a sleek stylish finish.

Type B - Oblong Slots:
Three rows of oblong slots in a grained stainless steel finish.

Type C - Square Holes:
Three rows of squares in a grained stainless steel finish.

Type S - Stone-infill
Allows a section of tile to be inserted to provide a sleek continuous look. Suitable for 10-12mm stone / porcelain tiles. Bespoke depths available to order.



HEIGHT & WIDTH ADJUSTMENT

The grill is height adjustable in 1mm increments to suit tile thicknesses of 6mm to 20mm.

Additional spacers are available upon request for tiles thicker than 20mm.

The position of the grill in relation to the wall, is adjustable by up to 37mm to accommodate different wall tile thicknesses.

ADJUSTMENT

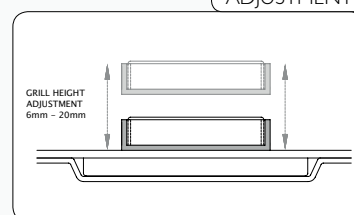

1.2 LINEAR WALL DRAIN



PRODUCT DETAILS

IMAGE	DESCRIPTION	GRILL LENGTH	PRODUCT REF
	Single trap Linear Wall Drain, supplied with solid grill as standard ¹ Maximum flow rate 29 L/min	600 mm	LSW 1-600
		800 mm	LSW 1-800
		900 mm	LSW 1-900
		1000 mm	LSW 1-1000
		1100 mm	LSW 1-1100
		1200 mm	LSW 1-1200
		1300 mm	LSW 1-1300
		1400 mm	LSW 1-1400
		1500 mm	LSW 1-1500
	Double trap Linear Wall Drain, supplied with solid grill as standard ¹ Maximum flow rate 57 L/min	600 mm	LSW 2-600
		800 mm	LSW 2-800
		900 mm	LSW 2-900
		1000 mm	LSW 2-1000
		1100 mm	LSW 2-1100
		1200 mm	LSW 2-1200
		1300 mm	LSW 2-1300
		1400 mm	LSW 2-1400
		1500 mm	LSW 2-1500
	Triple trap Linear Wall Drain, supplied with solid grill as standard ¹ Maximum flow rate 70 L/min	600 mm	LSW 3-600
		800 mm	LSW 3-800
		900 mm	LSW 3-900
		1000 mm	LSW 3-1000
		1100 mm	LSW 3-1100
		1200 mm	LSW 3-1200
		1300 mm	LSW 3-1300
		1400 mm	LSW 3-1400
		1500 mm	LSW 3-1500

¹ Type A – Solid Grill is supplied as standard. For alternative grill finishes please see page 3.

I.2 LINEAR WALL DRAIN

WATERPROOFING

IMAGE	DESCRIPTION	PRODUCT REF
	<p>RIW Tilesafe – A superior waterproof membrane designed for use in wetrooms, prior to the application of ceramic tiles and natural stone².</p> <ul style="list-style-type: none"> • Self-adhesive • Lifetime Guarantee • Quick and easy to install • De-coupling and acoustic properties 	<p>TSK-5 (5m² kit) TSK-10 (10m² kit)</p>
	<p>RIW Screedsafe – A waterproof membrane designed for use in wetrooms, prior to the application of ceramic tiles and natural stone².</p> <ul style="list-style-type: none"> • Self-adhesive • Quick and easy to install 	<p>SSK-5 (5m² kit) SSK-10 (10m² kit)</p>
	<p>RIW FWM – A liquid membrane designed for waterproofing walls, fully compatible with Tilesafe and Screedsafe².</p>	<p>FWM-8 (8kg)</p>

² For full technical details please refer to section 4

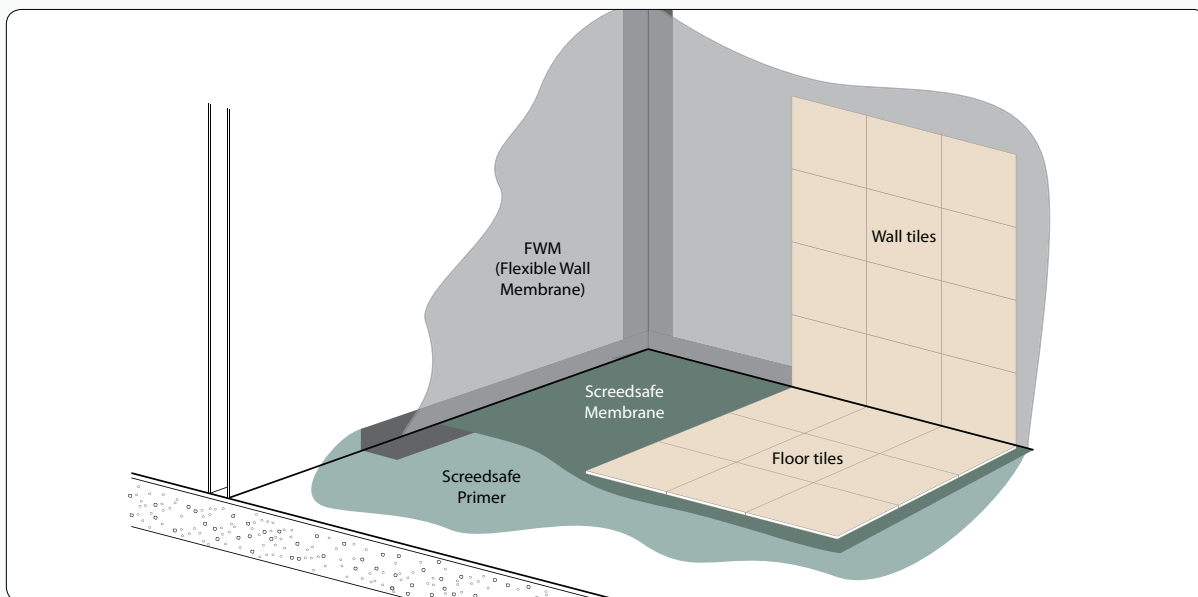

1.2 LINEAR WALL DRAIN

HOW TO SPECIFY

To specify your Linear Wall Drain, first select the required number of traps (depending on the required flow rate), followed by the grill length and finally the grill finish.

Membrane

It is essential that the floor is waterproofed or 'tanked' using one of the RIW membranes in either section 4.1 for timber floor or 4.2 for concrete/screeded floor.

For solid floors we recommend the Tilesafe/Screedsafe membrane is applied to the shower area plus an additional one metre in either direction.

FWM should then be applied to the walls of the shower area plus an additional 300mm and overlapped onto the Tilesafe/Screedsafe Reinforcing Tape.

Example: A single trap, 600mm Linear Wall Drain with solid grill would be code: **LSW1-600/Type A**

Example: A double trap, 800mm Linear Wall Drain with a Stone-Infill Grill would be code: **LSW2-800/Type S**

IN DETAIL

SIDE VIEW

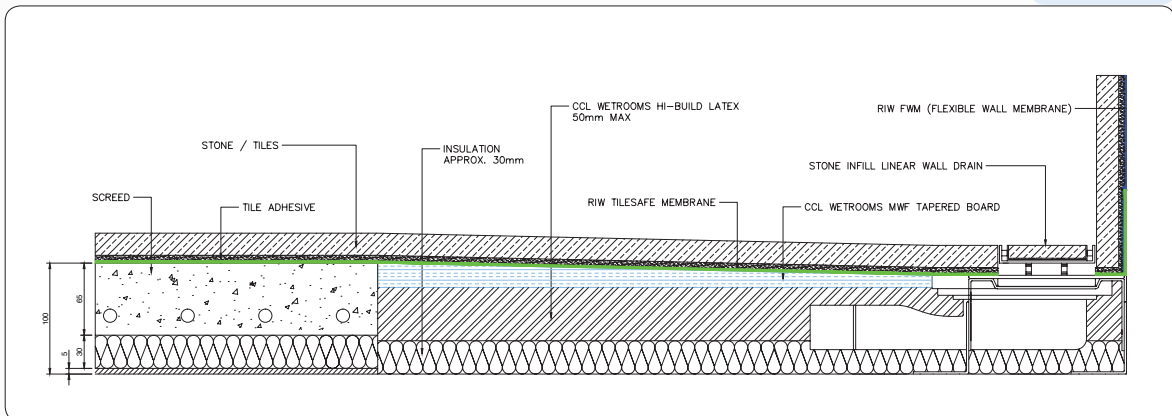

SIDE VIEW

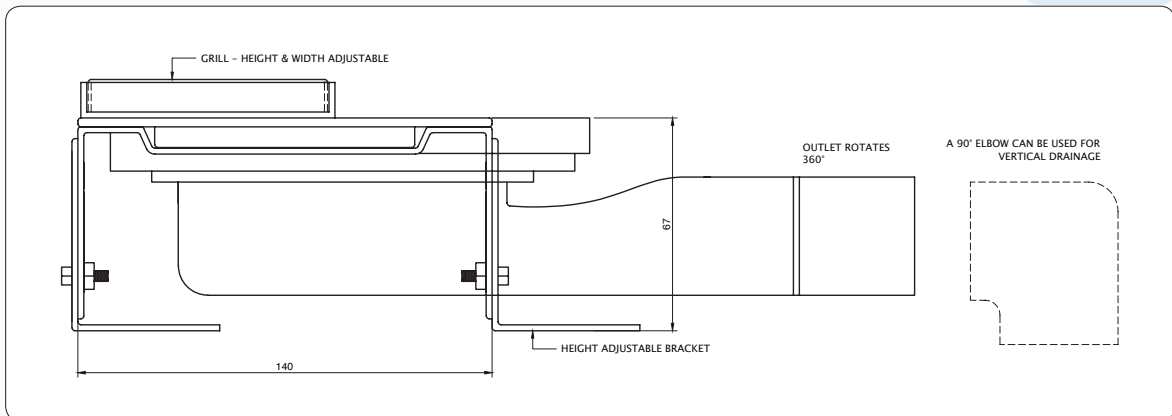

1.2 LINEAR WALL DRAIN

LSW1

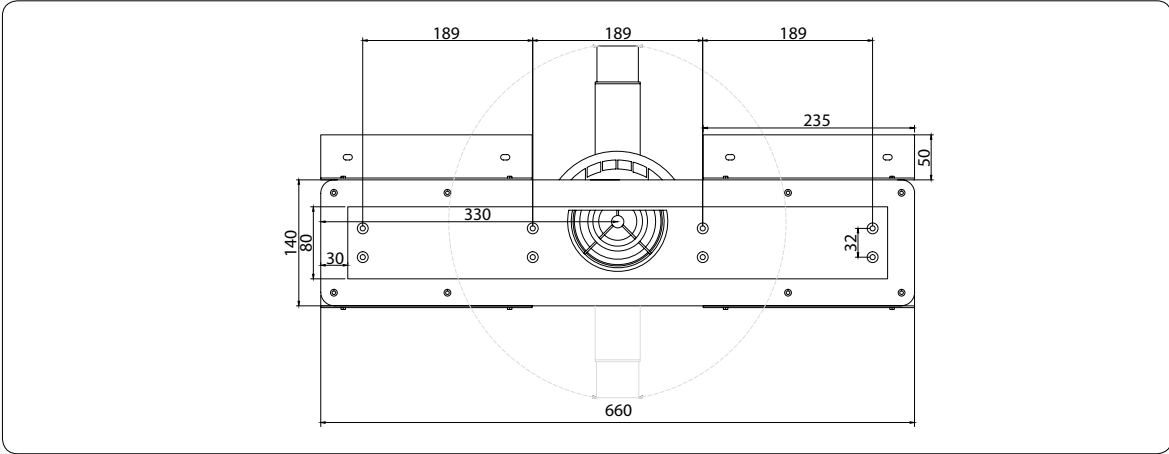

LSW2

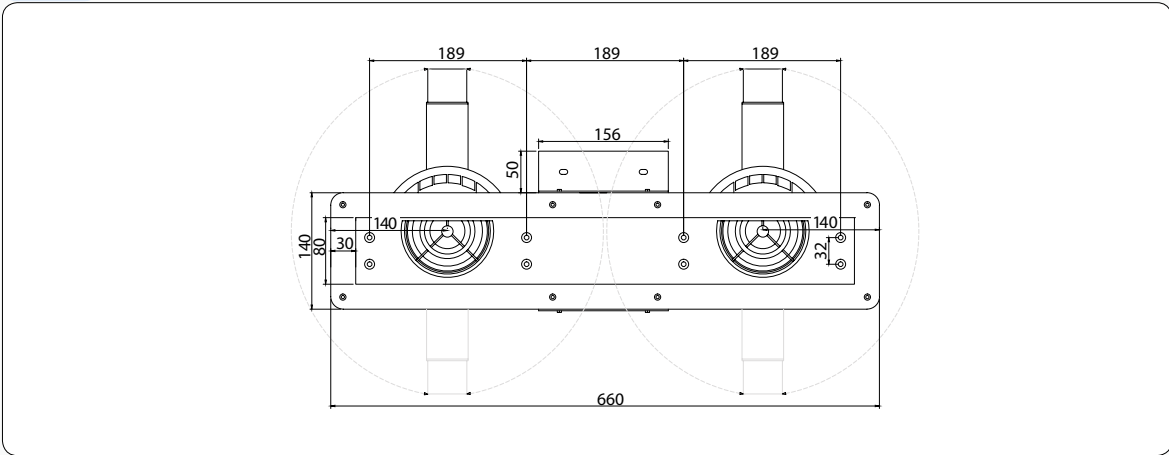

LSW3

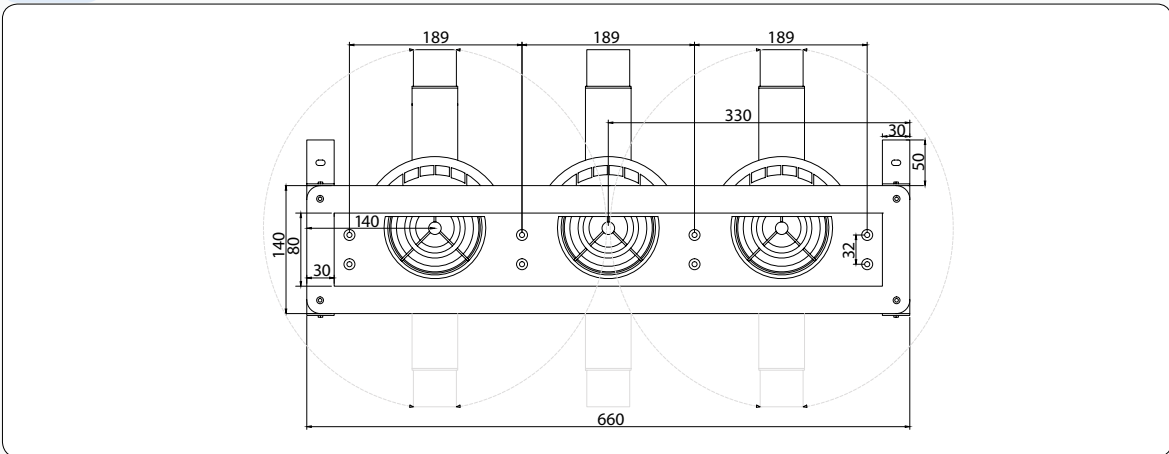

TECHNICAL SUPPORT

For technical assistance please contact our experienced technical department who will be happy to assist in the following:

- Project design
- Product specification
- CAD drawings
- Method statements

TECHNICAL SEMINARS

We are able to provide CPD based seminars designed to provide guidance on key wetroom design considerations such as;

- Design and layout
- Drainage
- Waterproofing
- Flow rates

For further information please contact our technical department.

TECHNICAL ADVICE

Our team of technical advisors are able to visit you to provide a professional advisory service and assist with project design and specification.

We are also able to attend site to provide technical support and assistance.

TECHNICAL ENQUIRIES

TEL: 0844 327 6002

Fax: 01256 765100

technical@ccl-wetrooms.co.uk

www.ccl-wetrooms.co.uk

CCL Specialist Supplies Ltd

Lodge Farm
Hook Road
North Wamborough
Hook
RG29 1HA



INSTALLATION

With over 30 years experience in the waterproofing industry, our involvement in a project from conception to completion ensures that quality is never compromised.

Our services include;

- Design and installation
- 10 Year Insured Installation guarantee
- On-site training

INSTALLATION ENQUIRIES

TEL: 0845 045 6001

Fax: 01256 765100

enquiries@wetroomsuk.co.uk

www.wetroomsuk.co.uk

Wetrooms UK Ltd

Lodge Farm, Hook Road
North Wamborough
Hook
RG29 1HA



part of
the CCL
group



PEACE OF MIND
GUARANTEED