

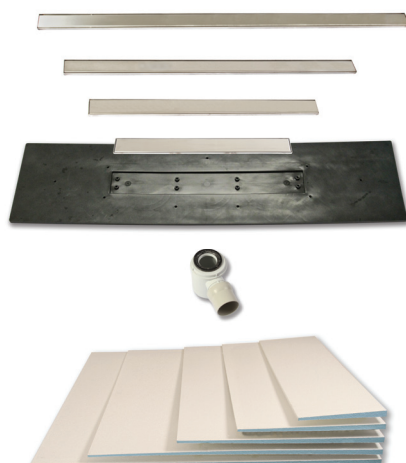

SECTION 2 MODULAR WET-FLOOR



PRODUCT SPECIFICATION GUIDE

2.1 MODULAR WET-FLOOR

FINISHED PRODUCT



The Modular Wet-Floor system is a unique concept in wetroom technology that can be used in a number of configurations to create a wetroom on a timber floor.

The system is versatile and cost effective and can be installed with the linear drain in either the centre of the shower area, or neatly positioned against the wall.

Consisting of three main elements, the Modular Wet-Floor is simple to configure. Start by selecting the required number of Drainage Components and Tapered Boards, then simply choose the appropriate Floor or Wall Grill to suit your wetroom layout.

The Drainage Component and Tapered Boards can then be easily trimmed on-site, making the whole system quick and easy to install.

KEY FEATURES

- Modular system
- Easily trimmed
- Quick and easy to install
- One or two way fall
- Ideal for large format tiles
- Floor or wall grill option
- Variable waste position
- Flow rate up to 68 L/min
- Height adjustable grill
- Lifetime guarantee

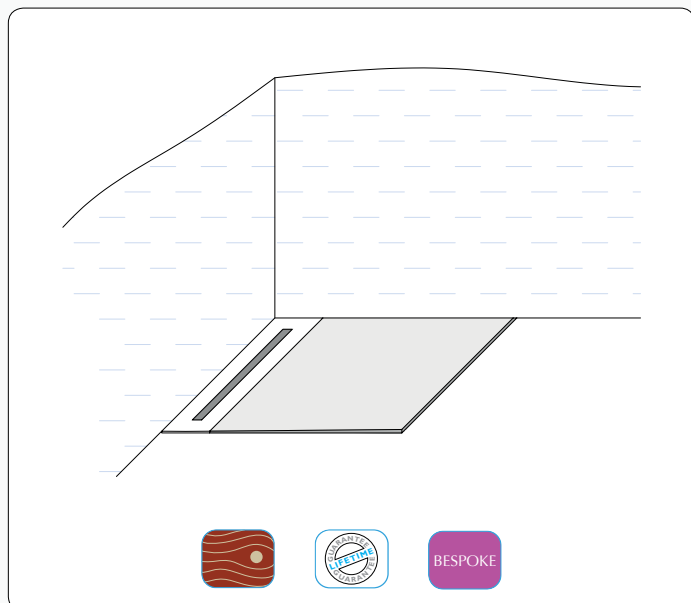

2.1 MODULAR WET-FLOOR

SYSTEM COMPONENTS

The Modular Wet-Floor system comprises of three main elements:

- 1 Drainage Component
- 2 Tapered Board
- 3 Floor/Wall Grill

1

Select the required number of drainage components.

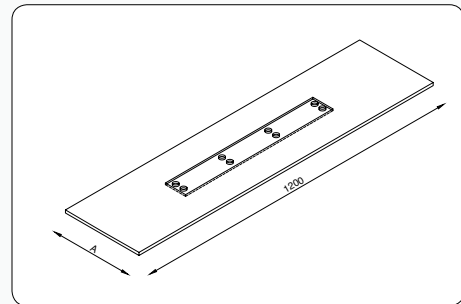

+

2

Select the required number of Tapered boards.

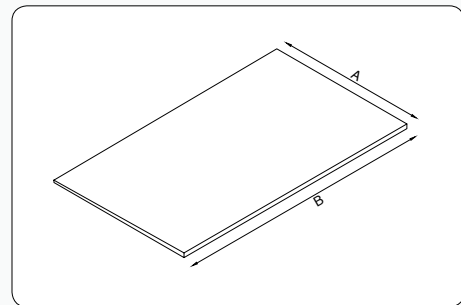

+

3

Select the appropriate floor or wall grill, along with the correct number of traps depending on the required flow rate.



The drainage component and Tapered boards can then be easily trimmed on site.

2.1 MODULAR WET-FLOOR

I DRAINAGE COMPONENT

Manufactured from tough ABS plastic, the Drainage Component is the central element of the Modular Wet-Floor, once its position has been decided, the remainder of the system is built around it.

Forming a base for the Linear Drain, the Drainage Component has a 1mm gradient towards the centre and can be installed in either an offset or central position

within the shower area, or neatly up against the wall to create a sleek and unobtrusive wall drain*.

The Drainage Component can be easily trimmed by up to 200mm off each end using a hand saw and is secured using the pre-drilled screw ports.

Two Drainage components can also be butted together to create a larger wetroom area.

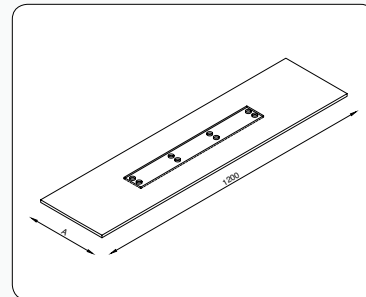

*When installed with the Wall Grill, the Drainage Component width is reduced by 80mm, to 220mm.

The Trap

The trap has an adjustable ball joint and comes with removable dip-tube.

For ease of installation it can be fitted anywhere within the central section of the Drainage Component, making it simple to avoid joists and other such obstructions.

- Floor or wall grill option
- Trimmable
- Variable waste position
- Multi-directional outlet
- 50mm Water seal
- BS1455 / 1566



No. of Traps

A single trapped Modular Wet-Floor has a flow rate of up to 27 L/min*

When a higher flow rate is required an additional trap can be installed, allowing up to 50 L/min*.

For higher flow rates a third trap can be installed giving up to 68 L/min*.

* See flow rate chart for full details.

ONE TRAP



TWO TRAPS



THREE TRAPS



FLOW RATES

No. of traps	No. of wastes		
	1	2	3
1	25 L/min	n/a	n/a
2	41 L/min	41 L/min	n/a
3	41 L/min	41 L/min	60 L/min
1	27 L/min	n/a	n/a
2	50 L/min	50 L/min	n/a
3	50 L/min	61 L/min	68 L/min

Stone / Solid-infill
Slotted / Square Holes

2.1 MODULAR WET-FLOOR

2 TAPERED BOARD

The Tapered Boards are manufactured from XPS foam with a mineral coating, making them both lightweight and easy to handle, whilst maintaining good thermal properties and compressive strength.

Each board is 1200mm long and tapered from 22mm to 11mm, giving a consistent gradient every time.

Available in five widths, the boards can be easily trimmed to size using a hand saw and should be secured with the fixing washers supplied, at a minimum of 300mm centres.

The system is designed with versatility in mind and can be installed in a number of different configurations.

See pages 7 to 10 for the most common layouts.

Using a combination of boards, either a one way fall towards the wall, or a two way fall with a central or offset drain can be created. Two or more Tapered Boards can also be butted together to create a larger wetroom area.

A 280mm x 300mm infill panel is available for use in certain configurations.

- Designed for timber floors
- One or two way fall
- Wetroom area can be varied to suit
- Easily trimmed
- Fixing washers included
- Quick and easy to install
- Ideal for large format tiles

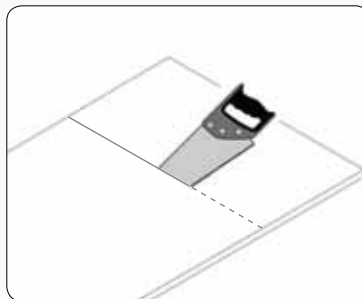
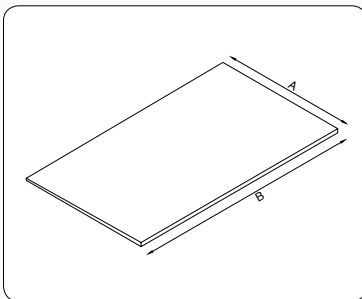

Tapered Boards are available in 6 standard sizes:

A **B**

- 300mm x 1200mm
- 500mm x 1200mm
- 700mm x 1200mm
- 1000mm x 1200mm
- 1200mm x 1200mm
- 1500mm x 1200mm

Infill Panel

- 280mm x 300mm

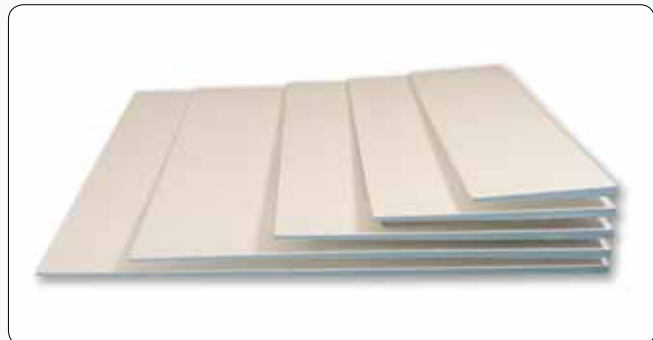

2.1 MODULAR WET-FLOOR

3 GRILL TYPE

There are two types of grill available within the Modular Wet-Floor system, both are designed to fit onto the Drainage Component.

Floor Grill

For installation in either an offset or central position within the shower area.

Grill width 58mm

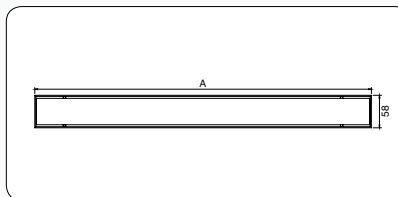

FLOOR GRILL

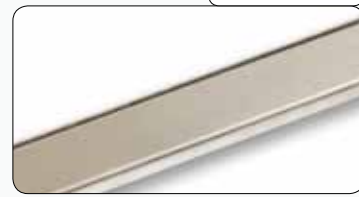

Wall Grill

For installation against the wall.

Grill width 86mm

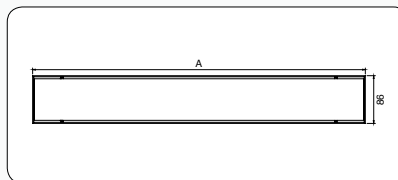

WALL GRILL



Grill length

The Drainage Component is manufactured with one trough size at 660mm, all lengths of grill are then fitted onto this trough.

The grill is available in nine standard sizes; two grills can be butted together to create a larger wetroom area (excluding 600mm grill).

- 600mm
- 800mm
- 900mm
- 1000mm
- 1100mm
- 1200mm
- 1300mm
- 1400mm
- 1500mm

9 GRILL LENGTHS



Bespoke grills can be manufactured for sizes in between and over those that are standard. Please contact our technical team to discuss your requirements.

2.1 MODULAR WET-FLOOR

3 GRILL TYPE - CONTINUED

Grill Finish

The grill is available in various different finishes.

All are manufactured in 316 marine grade stainless steel, ensuring a stunning high quality finish.

Type A Solid Grill is supplied as standard unless otherwise specified.

Type A - Solid Grill:
Grained stainless steel with a 3mm gap around the grill for a sleek stylish finish.

Type B - Oblong Slots:
Three rows of oblong slots in a grained stainless steel finish.

Type C - Square Holes:
Three rows of squares in a grained stainless steel finish.

Type S - Stone-infill
Allows a section of tile to be inserted to provide a sleek continuous look. Suitable for 10-12mm stone / porcelain tiles. Bespoke depths available to order.



Height & Width adjustment

The grill is height adjustable in 1mm increments to suit tile thicknesses of 6mm to 20mm.

Additional spacers are available upon request for tiles thicker than 20mm.

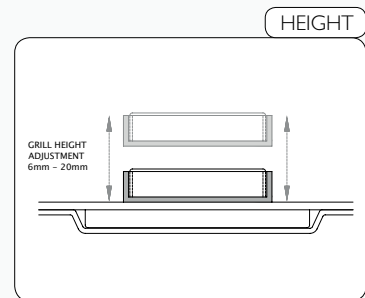

The Wall Grill is width adjustable to allow for different wall tile thicknesses.

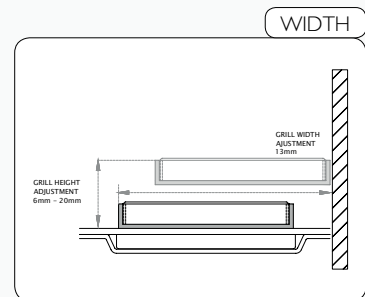

2.1 MODULAR WET-FLOOR

TYPICAL LAYOUTS

The Modular Wet-Floor is an extremely versatile system which can be installed in many possible combinations. The following examples show typical wetroom layouts that can be achieved, for further assistance please contact our technical team who will be pleased to advise.

LAYOUT 1

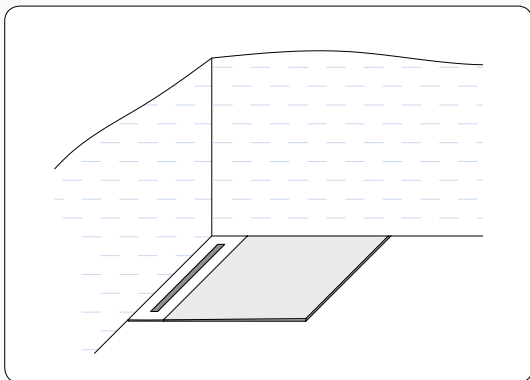

LAYOUT 2

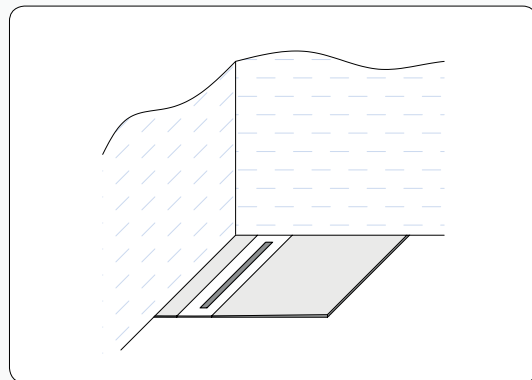

LAYOUT 3

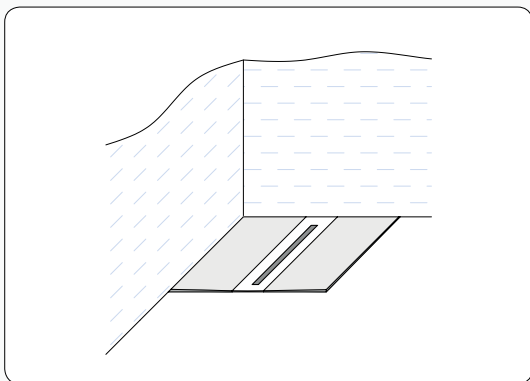

LAYOUT 4

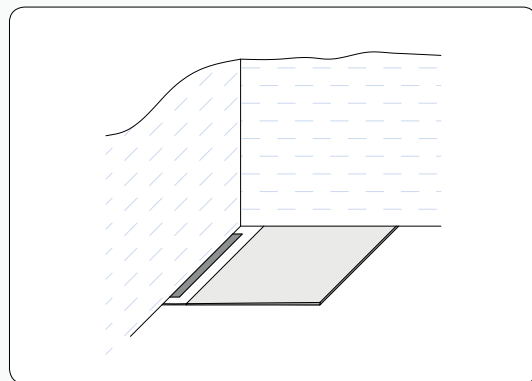

2.1 MODULAR WET-FLOOR

TYPICAL LAYOUTS

Examples showing typical wetroom layouts that can be achieved (continued).

LAYOUT 5

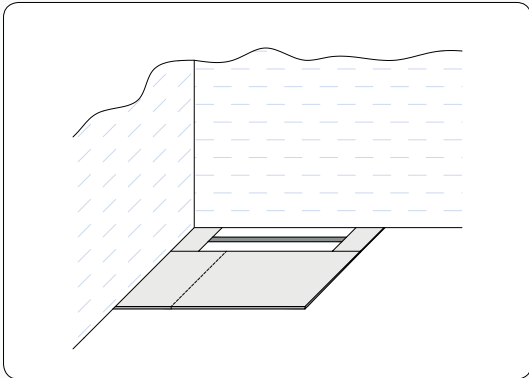

For layout 5 we recommend a maximum width of 1700mm, for widths greater than this use two Drainage Components, as layout 7.

LAYOUT 6

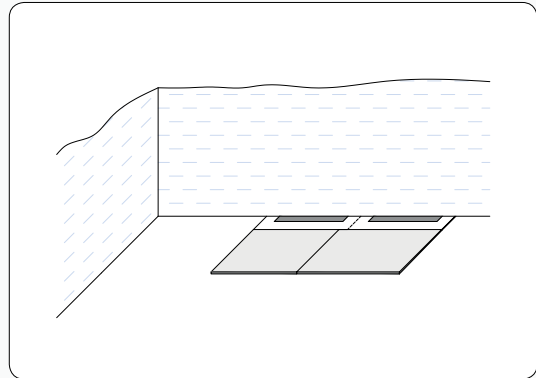

For layout 6 the minimum width required is 1700mm

LAYOUT 7

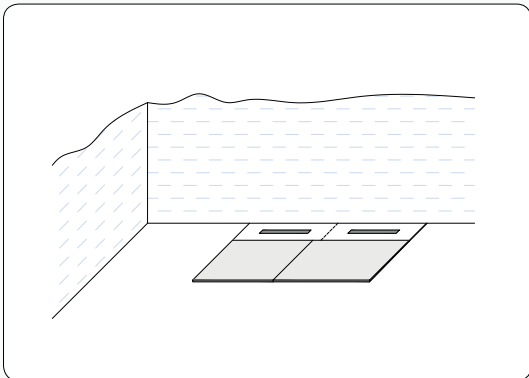

For layout 7 the minimum width required is 1700mm



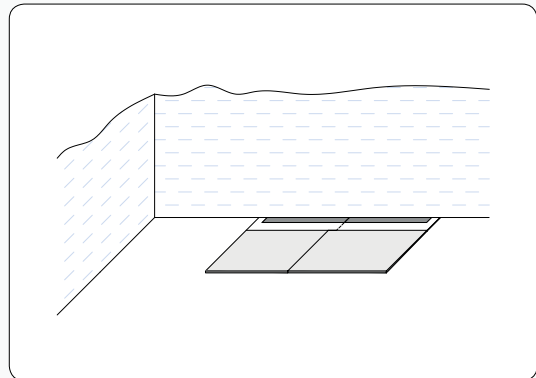





LAYOUT 8

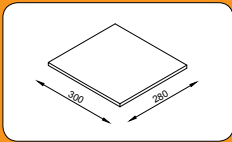

For layout 8 the minimum width required is 1800mm

2.1 MODULAR WET-FLOOR

PRODUCT DETAILS

	IMAGE	DESCRIPTION	SIZE	PRODUCT REF
1 DRAINAGE COMPONENT		Drainage Component with 1 trap. Maximum flow rate 27 L/min	1200mm x 300mm	MDC-1
		Drainage Component with 2 traps. Maximum flow rate 50 L/min	1200mm x 300mm	MDC-2
		Drainage Component with 3 traps. Maximum flow rate 68 L/min	1200mm x 300mm	MDC-3
2 TAPERED BOARD		Tapered board 22mm-11mm	300mm x 1200mm 500mm x 1200mm 700mm x 1200mm 1000mm x 1200mm 1200mm x 1200mm 1500mm x 1200mm	MTB-03 MTB-05 MTB-07 MTB-10 MTB-12 MTB-15
		Infil Panel	280mm x 300mm	MIP-1
		Additional fixing washers	Pack of 50	MFW-1
3 GRILL TYPE		Floor Grill Type A - Solid*	600mm 800mm 900mm 1000mm 1100mm 1200mm 1300mm 1400mm 1500mm	MFG-06 MFG-08 MFG-09 MFG-10 MFG-11 MFG-12 MFG-13 MFG-14 MFG-15
		Wall Grill Type A - Solid*	600mm 800mm 900mm 1000mm 1100mm 1200mm 1300mm 1400mm 1500mm	MWG-06 MWG-08 MWG-09 MWG-10 MWG-11 MWG-12 MWG-13 MWG-14 MWG-15

*The Type A – Solid Grill is supplied as standard, for alternative grill finishes please see page 6

2.1 MODULAR WET-FLOOR

HOW TO SPECIFY

To specify your Modular Wet-Floor first decide the layout of your wetroom, then simply follow the three step process:

- Step **1** Select the required number of Drainage Components and Traps
- Step **2** Select the required number and size of Tapered Boards
- Step **3** Select the required Floor or Wall Grill

Note: The Drainage Component and Tapered Boards can be easily trimmed on-site.
Two Drainage Components and Grills can be butted together to create a larger wetroom area.

EXAMPLES

EXAMPLE CONFIGURATIONS:

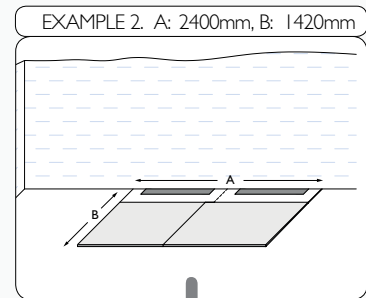
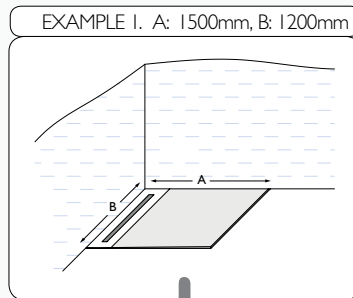
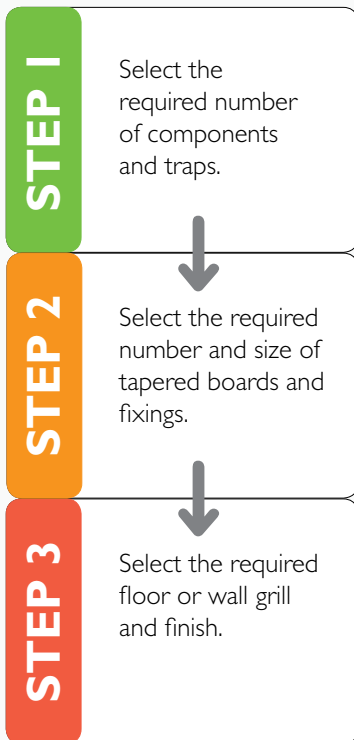

Drainage Component with 1 trap.
MDC-1

2 x Drainage Component with 1 trap.
2 x **MDC-1**

1200mm Tapered Board.
MTB-12

2 x 1200mm Tapered Board.
2 x **MTB-12**



600mm Solid Floor Grill.
MFG-06/TYPE A

2 x 800mm Slotted Wall Grill.
MWG-08/TYPE B

2.1 MODULAR WET-FLOOR

WATERPROOFING

It is essential that the floor is waterproofed or 'tanked' using the following membranes.

IMAGE	DESCRIPTION	PRODUCT REF
	<p>RIW Tilesafe – A superior waterproof membrane designed for use in wetrooms, prior to the application of ceramic tiles and natural stone².</p> <ul style="list-style-type: none"> • Self-adhesive • Quick and easy to install • Lifetime Guarantee • De-coupling and acoustic properties 	<p>TSK-5 (5m² kit) TSK-10 (10m² kit)</p>
	<p>RIW FWM – A liquid membrane designed for waterproofing walls, fully compatible with Tilesafe and Screedsafe².</p>	<p>FWM-8 (8kg)</p>

¹ For full technical details please refer to section 4

For timber floors we would recommend the Tilesafe membrane is applied to the entire wetroom floor.

FWM should then be applied to the walls of the shower area plus an additional 300mm and overlapped onto the Tilesafe Reinforcing Tape.

IN DETAIL

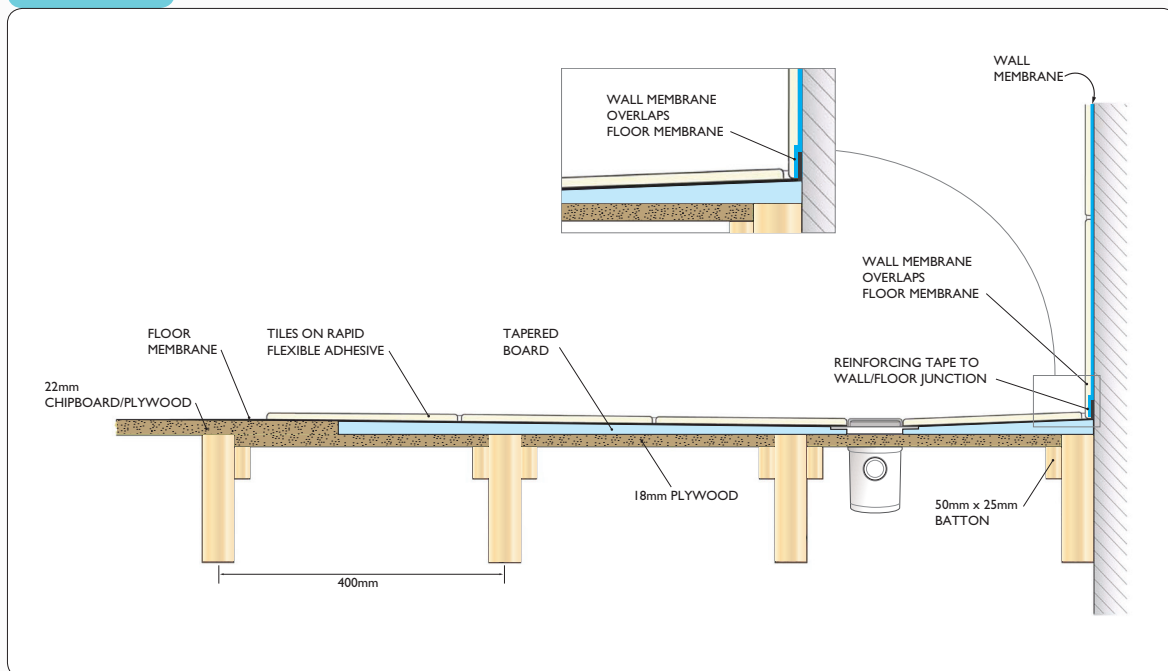

2.1 MODULAR WET-FLOOR

DRAINAGE COMPONENT

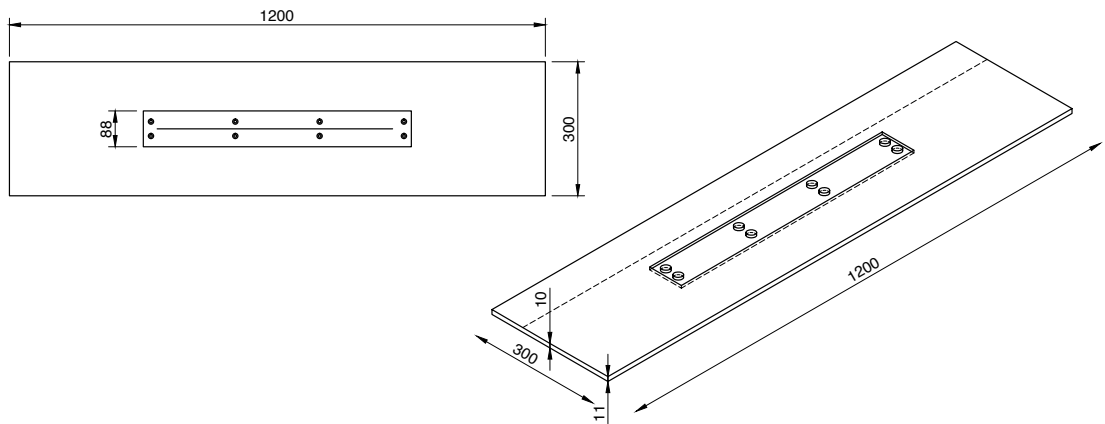

TAPERED BOARD

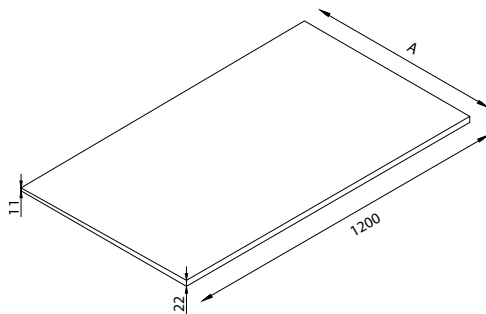

INFIL PANEL

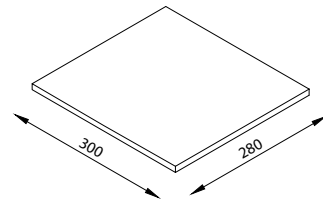

TAPERED BOARDS - PERFORMANCE & COMPOSITION

Density	2.80 - 4.30 kg/m
Thermal Conductivity	0.028 - 0.035 w/mK
Compressive Strength	3kg/cm ² (300kN/m ²)
Water absorption (immersion)	Din 53428 0.2% by vol
Water absorption (capillary)	Din 53428 Nil
Coefficient of linear expansion	ASMT D-696 14.5 × 10.5
Flammability	Class 0, B1/B2 (depending on the conditions of application)

Full technical data sheet available on request from our technical department.

2.1 MODULAR WET-FLOOR

FLOOR DRAIN

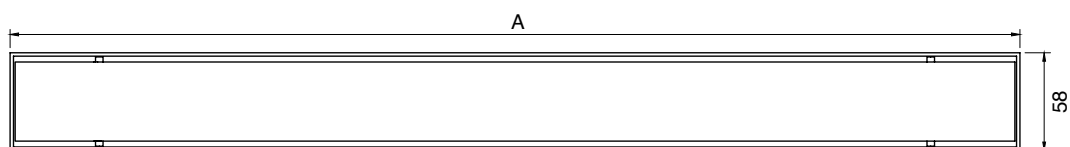

WALL DRAIN

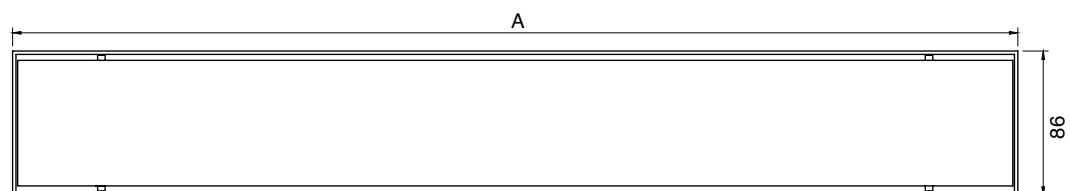

TRAP

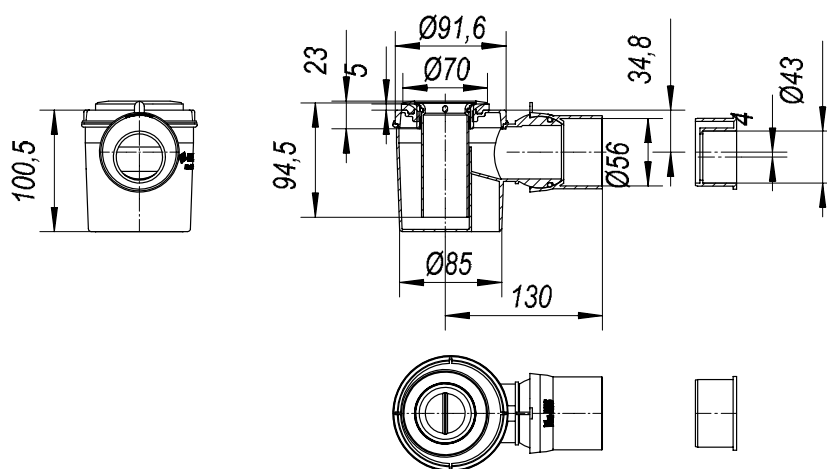

TECHNICAL SUPPORT

For technical assistance please contact our experienced technical department who will be happy to assist in the following;

- Project design
- Product specification
- CAD drawings
- Method statements

TECHNICAL SEMINARS

We are able to provide CPD based seminars designed to provide guidance on key wetroom design considerations such as;

- Design and layout
- Drainage
- Waterproofing
- Flow rates

For further information please contact our technical department.

TECHNICAL ADVICE

Our team of technical advisors are able to visit you to provide a professional advisory service and assist with project design and specification.

We are also able to attend site to provide technical support and assistance.

TECHNICAL ENQUIRIES

TEL: 0844 327 6002

Fax: 01256 765100

technical@ccl-wetrooms.co.uk

www.ccl-wetrooms.co.uk

CCL Specialist Supplies Ltd

Lodge Farm
Hook Road
North Wamborough
Hook
RG29 1HA



INSTALLATION

With over 30 years experience in the waterproofing industry, our involvement in a project from conception to completion ensures that quality is never compromised.

Our services include;

- Design and installation
- 10 Year Insured Installation guarantee
- On-site training

INSTALLATION ENQUIRIES

TEL: 0845 045 6001

Fax: 01256 765100

enquiries@wetroomsuk.co.uk

www.wetroomsuk.co.uk

Wetrooms UK Ltd

Lodge Farm, Hook Road
North Wamborough
Hook
RG29 1HA



part of
the CCL
group



PEACE OF MIND
GUARANTEED