

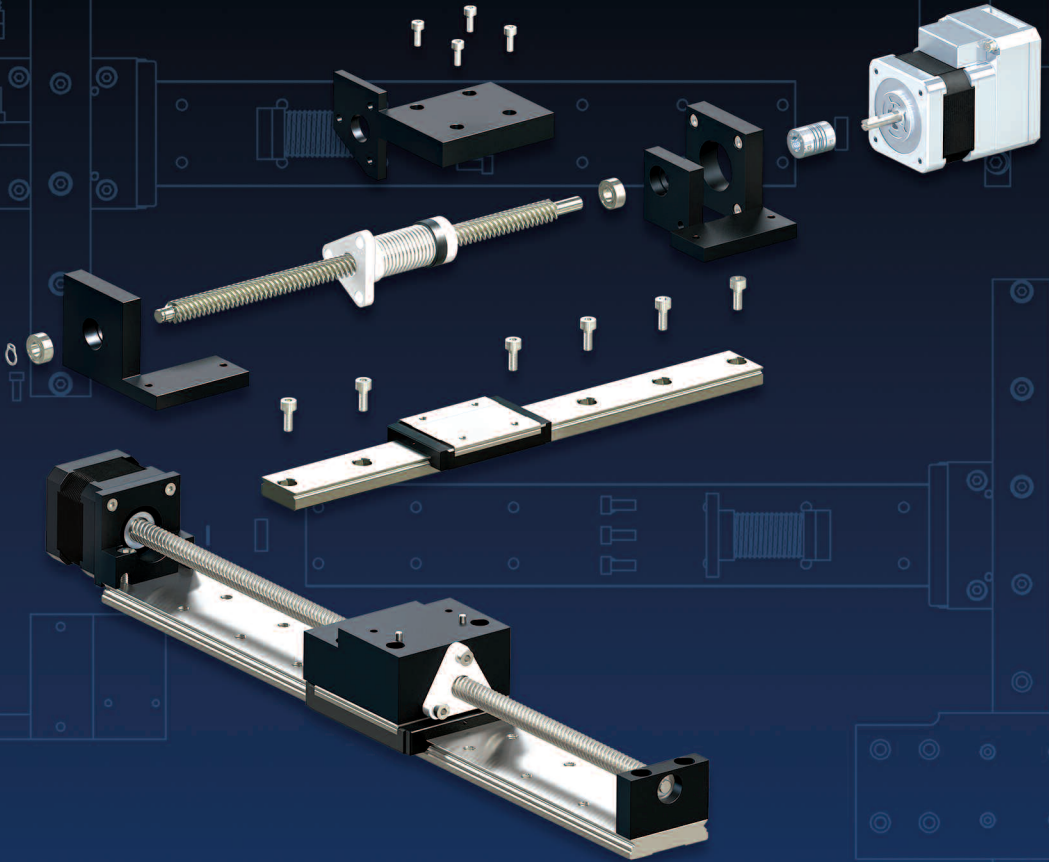

Reliance[®] Precision Limited

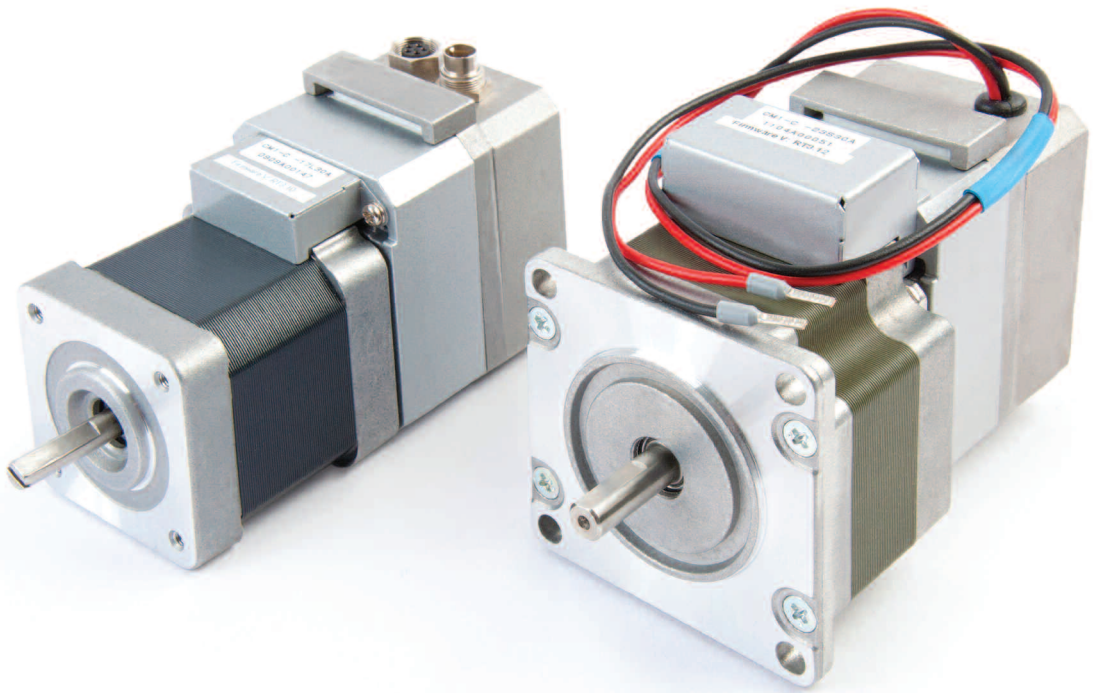

Precise Motion Control Solutions
Intelligent Motors and Motorised Actuators



Section Contents

- Reliance Cool Muscle Motor - OverviewPage 2-2
 - RCM1 Motor NEMA 11Page 2-4
 - RCM1 Motor NEMA 17Page 2-6
 - RCM1 Motor NEMA 23Page 2-8
 - Specifications and CablesPage 2-10
 - AccessoriesPage 2-12
 - Associated ProductsPage 2-13
- Reliance Rack Actuators - OverviewPage 2-14
 - Tubular Rack Actuators Size 17Page 2-15
 - Solid Rack Actuators Size 23Page 2-16
 - Solid Rack Actuators Size 17Page 2-17
- Bespoke Motorised Actuators.....Page 2-18
- Reliance Cool Muscle Stage - Overview.....Page 2-19
 - Reliance Cool Muscle Stage Size 17Page 2-20
 - Reliance Cool Muscle Stage Size 23Page 2-22
- Linear Actuators - OverviewPage 2-24
- Linear Rail Actuator - OverviewPage 2-26
 - Linear Rail Actuator Size 17Page 2-27
- Motorised Leadscrew Linear Slide - OverviewPage 2-28
- Technical Information.....Page T2-1



A complete motion control solution

This cost-effective miniature servo system combines a precision stepper motor and high resolution encoder with sophisticated drive and control electronics in a single, compact unit.



- NEMA sizes 11, 17 and 23 each with two frame lengths
- Encoder resolution of 50,000 counts per revolution
- Speeds from 0 to 3,000 RPM
- Continuous torques from 0.027 to 0.87 Nm (1.24 Nm peak)
- H-infinity controller and vector drive for fully closed loop control of position, speed and torque. Tuning not required in most applications.
- Fully programmable for standalone operation
- RS232 and USB communications as standard
- Options for RS485, PROFIBUS and Ethernet
- Digital and analogue input and output
- Safe and efficient 24V DC operation

Compared with an equivalent size of stepper motor Cool Muscle works faster, with more available torque, it is more efficient and generates less heat.

Closed loop control means no step loss. In an open loop system it is possible for the motor to fail to move the exact number of steps if it is overloaded. Cool Muscle, being a closed loop control system, is able to identify any potential for step loss and to correct it.

Cool Muscle is available with two types of control interface: Pulse Type (P) and Computer Type (C). The P-Type is applicable for a drive and stepper system with step-pulse control, such as a PLC. Cool Muscle provides an effective drop-in solution to resolve step loss problems and also provides a more integrated solution, having a combined stepper and drive. The C-Type offers a higher level of computer control in a single integrated unit which can remove the need for a separate controller or, in more complex systems, reduce the investment required in additional controllers.

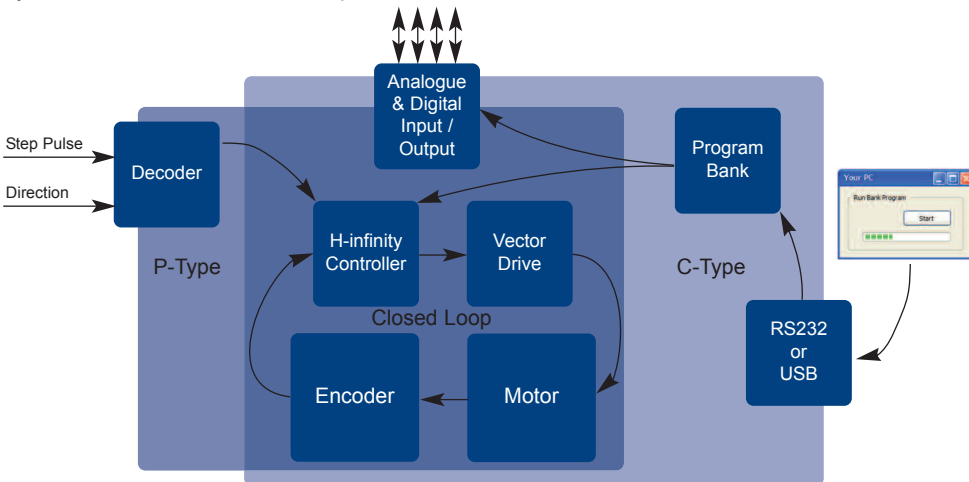



Cool Muscle's unique features include the ability to link up to 15 motors which can operate together in complex sequences without an additional controller. Cool Muscle is able to use a physical limit of travel as its reference position, using torque sensing to safely and accurately find the limits of travel without needing a position sensor (e.g. limit switch).

The high level of integration provided by Cool Muscle reduces cabling, keeps components to a minimum and speeds up system assembly.

Cool Muscle is ideal for laboratory and test equipment or for light industrial automation.

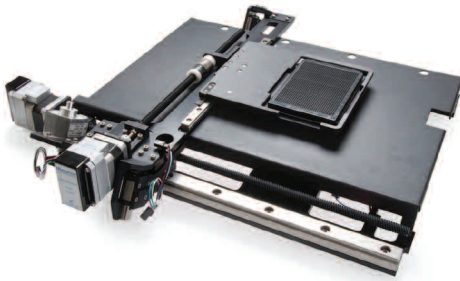

Customised XYZ positioning table

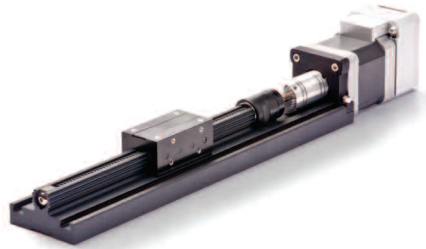

Precision linear stage

Intelligent
Motors



Medical pipetting systems

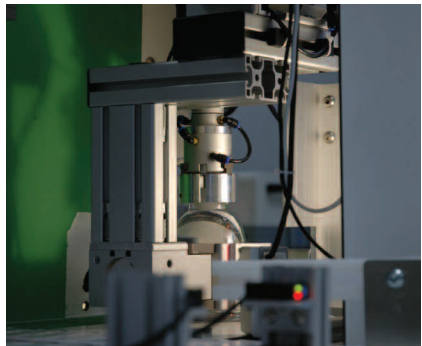

Laboratory automation

Motorised actuators

Reliance supplies pre-built motion stages with integrated Cool Muscle motors, see [page 2-19](#). We also manufacture unique, high-speed precision rack actuators fitted with Cool Muscle, available with solid racks or tubular racks, ideal for pipette systems, see [page 2-14](#).



All dimensions in mm

Associated Products

- Couplings: [page 8-1](#)
- Leadscrews: [page 7-1](#)
- Hardware: [page 13-1](#)
- Cables: [page 2-11](#)

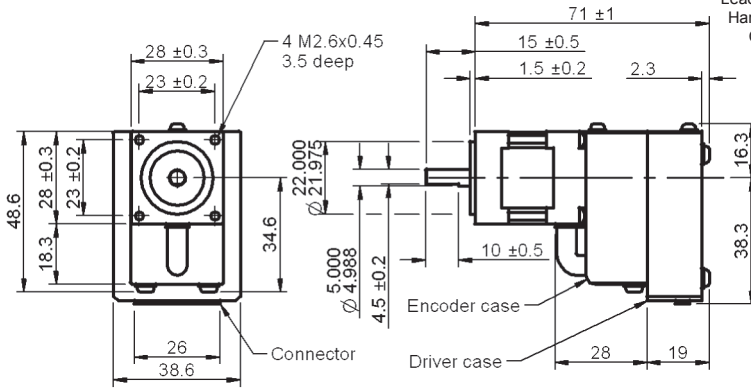

RCM1 - P - 11 S 30 - RT3

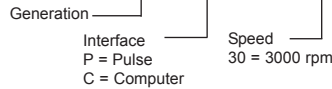

Specification table

	RCM1-□-11S30-RT3
Motor output power	9 W
Maximum speed	3,000 rpm
Continuous torque	0.027 Nm
Peak torque	0.039 Nm
Load inertia allowance	80 g-cm ²
Motor inertia	8g -cm ²
Input supply current rated (Continuous torque/rated peak torque)	0.8 A/1.0 A
Weight	246 g

Torque curve

RCM1-□-11S30-RT3

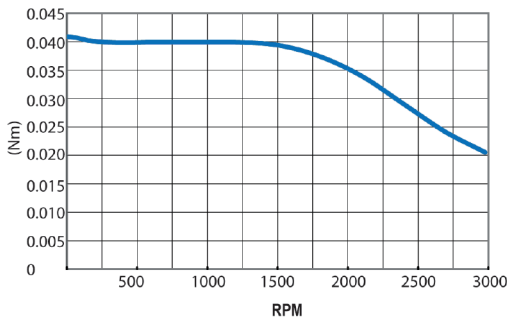

Technical support

- Product overview - see [page 2-2](#)
- Technical information - see [page T2-1](#)
- P & C interface - see [page T2-2](#)
- Software interface - see [page T2-3](#)
- Electrical interface - see [page T2-5](#)
- Cables - see [page 2-11](#)
- Accessories - see [page 2-12](#)



Associated Products

Couplings: page 8-1
 Leadscrews: page 7-1
 Hardware: page 13-1
 Cables: page 2-11

All dimensions in mm

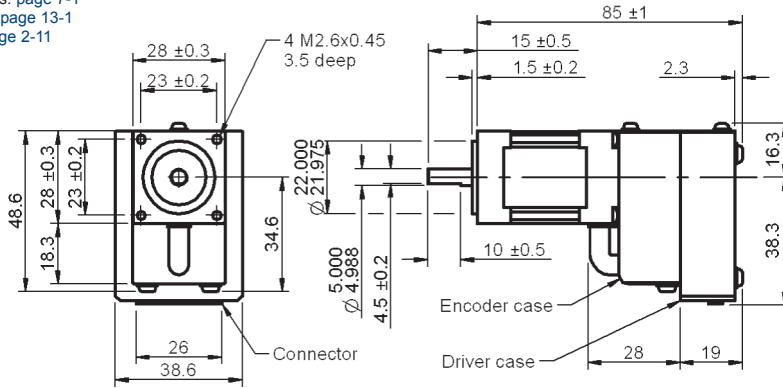

RCM1 - P - 11 L 30 - RT3

Generation
 Interface
 P = Pulse
 C = Computer
 Speed
 30 = 3000 rpm

Specification table

	RCM1-□-11L30-RT3
Motor output power	18 W
Maximum speed	3,000 rpm
Continuous torque	0.055 Nm
Peak torque	0.078 Nm
Load inertia allowance	180 g-cm ²
Motor inertia	18 g-cm ²
Input supply current rated (Continuous torque/rated peak torque)	1.2 A/1.5 A
Weight	300 g

Torque curve

RCM1-□-11L30-RT3

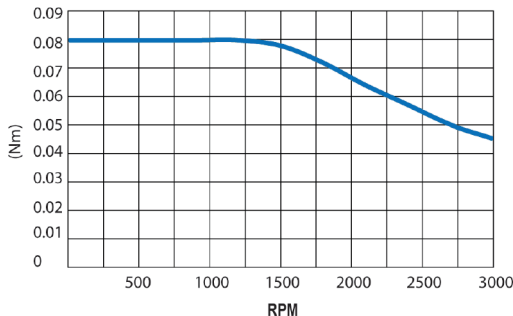

Technical support

- Product overview - see page 2-2
- Technical information - see page T2-1
- P & C interface - see page T2-2
- Software interface - see page T2-3
- Electrical interface - see page T2-5
- Cables - see page 2-11
- Accessories - see page 2-12

Intelligent Motors



All dimensions in mm

Associated Products

Planetary Gearboxes: [page 3-3](#)

Couplings: [page 8-1](#)

Leadscrews: [page 7-1](#)

Hardware: [page 13-1](#)

Cables: [page 2-11](#)

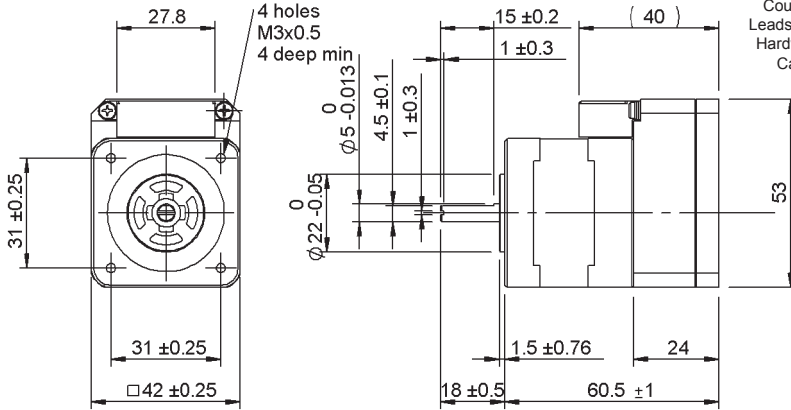

RCM1 - P - 17 S 30-C - RT3

Generation
Interface P = Pulse
C = Computer
Speed 30 = 3000 rpm

Specification table

	RCM1- □ - 17S30-C-RT3
Motor output power	18 W
Maximum speed	3,000 rpm
Continuous torque	0.082 Nm
Peak torque	0.117 Nm
Load inertia allowance	380 g-cm ²
Motor inertia	36 g-cm ²
Input supply current rated (Continuous torque/rated peak torque)	0.8 A/1.0 A
Weight	325 g

Torque curve

RCM1- □ - 17S30-C-RT3

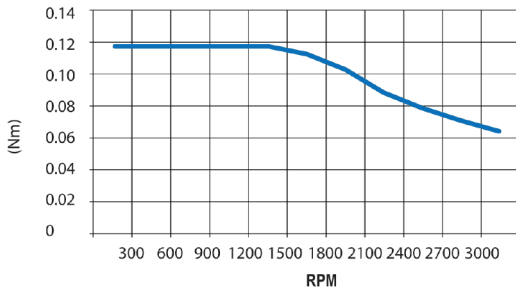

Technical support

- Product overview - see [page 2-2](#)
- Technical information - see [page T2-1](#)
- P & C interface - see [page T2-2](#)
- Software interface - see [page T2-3](#)
- Electrical interface - see [page T2-5](#)
- Cables - see [page 2-11](#)
- Accessories - see [page 2-12](#)



Associated Products

Planetary Gearboxes: [page 3-3](#)

Couplings: [page 8-1](#)

Leadscrews: [page 7-1](#)

Hardware: [page 13-1](#)

Cables: [page 2-11](#)

All dimensions in mm

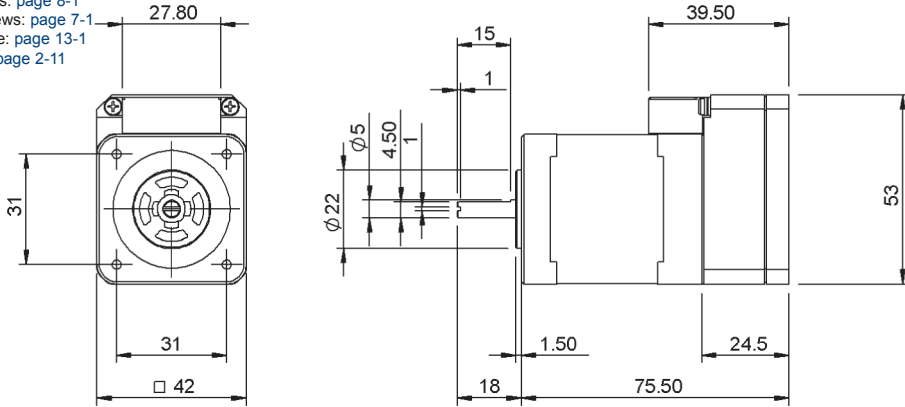

RCM1 - P - 17 L 30-C - RT3

Generation —
Interface — P = Pulse, C = Computer
Speed — 30 = 3000 rpm

Intelligent Motors

Specification table

	RCM1- □ -17L30-C-RT3
Motor output power	18 W
Maximum speed	3,000 rpm
Continuous torque	0.36 Nm
Peak torque	0.518 Nm
Load inertia allowance	760 g-cm ²
Motor inertia	74 g-cm ²
Input supply current rated (Continuous torque/rated peak torque)	1.5 A/1.8 A
Weight	470 g

Torque curve

RCM1- □ -17L30-C-RT3

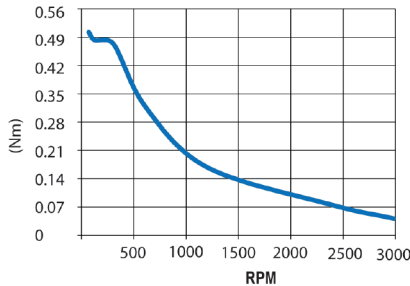

Technical support

- Product overview - see [page 2-2](#)
- Technical information - see [page T2-1](#)
- P & C interface - see [page T2-2](#)
- Software interface - see [page T2-3](#)
- Electrical interface - see [page T2-5](#)
- Cables - see [page 2-11](#)
- Accessories - see [page 2-12](#)



All dimensions in mm

Associated Products

Planetary Gearboxes: [page 3-3](#)

Couplings: [page 8-1](#)

Leadscrews: [page 7-1](#)

Hardware: [page 13-1](#)

Cables: [page 2-11](#)

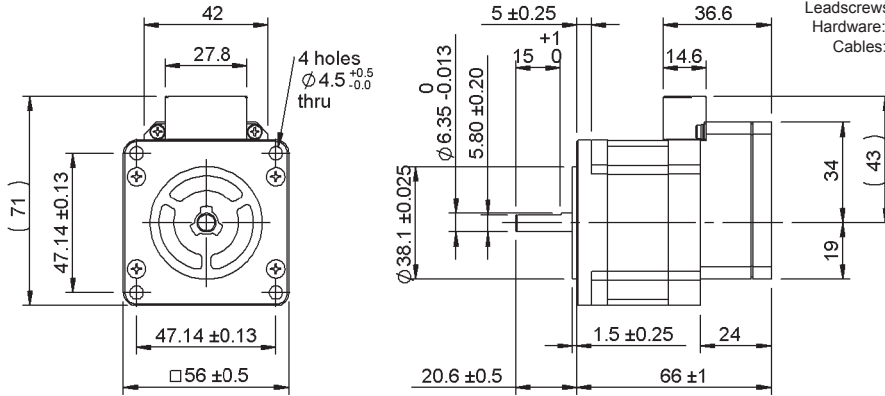

RCM1 - P - 23 S 30-C - RT3

Generation
Interface
P = Pulse
C = Computer
Speed
30 = 3000 rpm

Specification table

	RCM1- □ -23S30-C-RT3
Motor output power	45 W
Maximum speed	3,000 rpm
Continuous torque	0.29 Nm
Peak torque	0.42 Nm
Load inertia allowance	1.0x10 ³ g-cm ²
Motor inertia	1.0x10 ² g-cm ²
Input supply current rated (Continuous torque/rated peak torque)	3.9 A/5.1 A
Weight	580 g

Torque curve

RCM1- □ -23S30-C-RT3

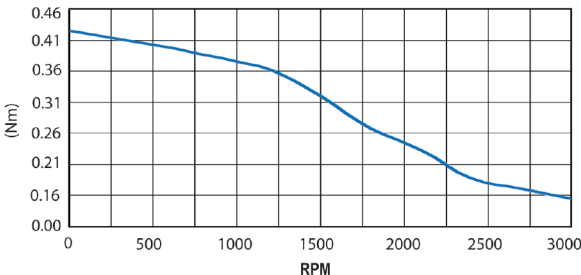

? Technical support

- Product overview - see [page 2-2](#)
- Technical information - see [page T2-1](#)
- P & C interface - see [page T2-2](#)
- Software interface - see [page T2-3](#)
- Electrical interface - see [page T2-5](#)
- Cables - see [page 2-11](#)
- Accessories - see [page 2-12](#)



Associated Products

Planetary Gearboxes: page 3-3

Couplings: page 8-1

Leadscrews: page 7-1

Hardware: page 13-1

Cables: page 2-11

All dimensions in mm

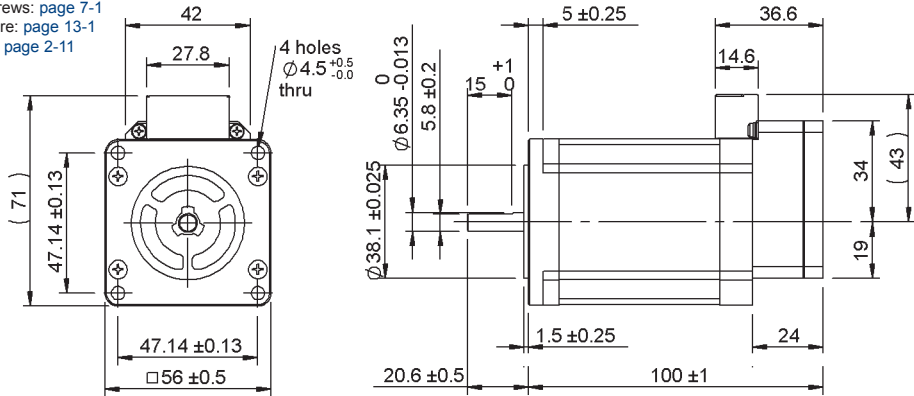

RCM1 - P - 23 L 20-C - RT3

Generation
Interface P = Pulse C = Computer
Speed 20 = 2000 rpm

Specification table

	RCM1- □ -23L20-C-RT3
Motor output power	30 W
Maximum speed	2,000 rpm
Continuous torque	0.87 Nm
Peak torque	1.24 Nm
Load inertia allowance	3.6x10 ³ g-cm ²
Motor inertia	3.6x10 ² g-cm ²
Input supply current rated (Continuous torque/rated peak torque)	2.6 A/3.4 A
Weight	1100 g

Torque curve

RCM1- □ -23L20-C-RT3

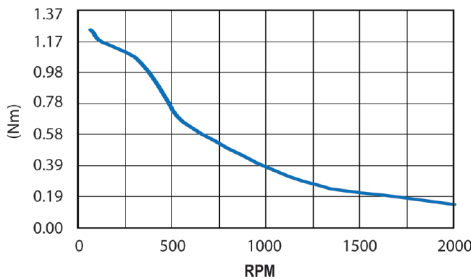

Technical support

- Product overview - see page 2-2
- Technical information - see page T2-1
- P & C interface - see page T2-2
- Software interface - see page T2-3
- Electrical interface - see page T2-5
- Cables - see page 2-11
- Accessories - see page 2-12

Intelligent Motors



General and environmental specifications

Encoder	Incremental magnetic encoder (50,000 pulses per rotation)
Control Method	Closed loop vector control
Input Supply Voltage	DC24 V±10%
Resolution Pulse Rotation (Pulse/Rotation)	200, 400, 500, 1000(default), 2000, 2500,5000, 10000, 25000,50000 Select by parameter
Ambient Operating Temperature	0°C to 40°C
Storage Temperature	-20°C to +60°C
Operating Humidity	Less than 90%RH
Shock	Less than 10 G
Vibration	Less than 1 G

Pin layout

For Reliance Cool Muscle electrical interfacing and connector pin layout see Technical Information [page T2-5](#).

Input/output signal

Pulse Interface	CW/CCW	Step/Direction
Input Signal Pulse Input P	CW/CCW Pulse	Step Pulse
	Maximum frequency: 500 Kpps Minimum pulse width: 0.8 µsec Voltage level H (with pulse) > +3.0 V (+24 Vmax) 7 mA-1 5mA Voltage level L (no pulse) < +0.8 V	Maximum frequency: 500 Kpps Minimum pulse width: 0.8 µsec Voltage level H (with pulse) > +3.0 V (+24 Vmax) 7 mA-15 mA Voltage level L (no pulse) < +0.8 V

Variable Voltage Interface - Now integrated into the C-Type motor

Input Signal	Speed Control setting
Analogue Input V	Increase the voltage from 2.6 V to 4.8 VDC to increase speed in the CW direction Decrease the voltage from 2.4 V to 0 VDC, to increase speed in the CCW direction. Use OP AMP for maximum resolution
	Position control setting Travel distance is proportionate to voltage input (between 0 V and 4.8 VDC) Maximum travel distance is set by a parameter

Computer Control Interface

Input Signal	Control
Input Signal Control Level C	Via supplied cabling - motor interface is TTL, please specify RS232 or RS485 interface option
	Voltage level high > 3 V (minimum 7 mA) Voltage level low < 0.8 V

RT3 Real Time Interface

Co-ordinated Motion	Allows 2 axes to work together to create accurate complex motion
Logic Banks	Embedded PLC up to 200 steps for mathematical calculation of motion
Quadrature	Simulated AB outputs from the magnetic encoder. Maximum frequency 20 kHz
Shared I/O	Inputs or outputs are available to be read and accessed by all motors running programs and logic banks



Software interface

For programming details for the C-Type Reliance Cool Muscle see Technical Information pages T2-3 to T2-5.

'Y' cables

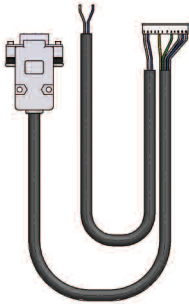

RCM1C3 - xx

Length of wires to first connector
(xx-xx if the two lengths are different)

Generic part number

Standard and customised daisy chain cables

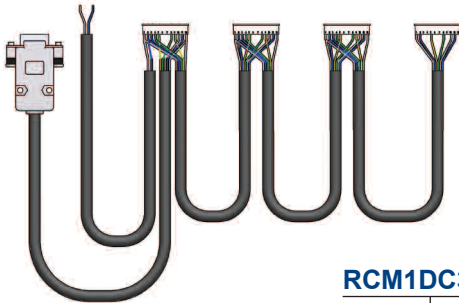

RCM1DC3A - xx - N - xx - xx - xx

Length of wire between connectors
(Only one number required if the lengths are all the same)

Number of connectors

Length of wires to first connector
(xx-xx if the two lengths are different)

Generic part number

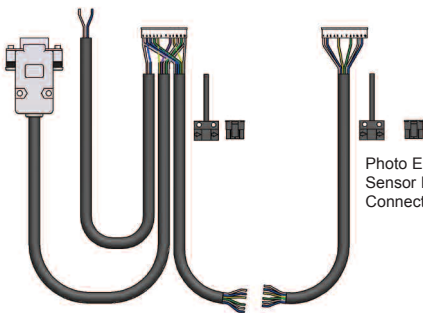
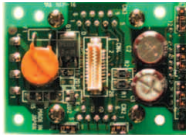

Photo Electric
Sensor Molex
Connector 2 way

i Product options

- For further information about customising cables, please contact us
- Customised cables are available with photosensors option



Communication cards

RS485, PROFIBUS and Ethernet cards are available as options for the Reliance Cool Muscle servo system. Our engineers provide technical support based on extensive experience integrating the Reliance Cool Muscle with third party controllers, HMIs and PLCs.

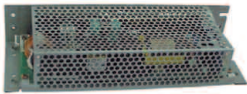

Power supply

Designed specifically for the Reliance Cool Muscle, this power supply is built to withstand the current draw spikes which the hard stops or starts often require. Specification of the power supply is 150 W/300 W, 6 A/10 A.

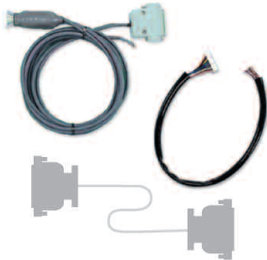

Cables

A standard motor cable (40 cm) and varistor are supplied with every motor. Longer motor cables are available as an option.

A Y-cable is required to connect the Reliance Cool Muscle to a USB or serial port, see [page 2-11](#)

Multi-motor custom cables can be made to suit your application.

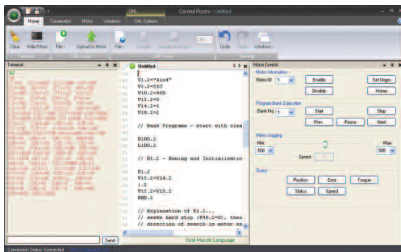

Control room

Control Room is a free application which provides basic tools for setting parameters and creating motion profiles. A user friendly interface makes it easy to work with the Reliance Cool Muscle.

Control Room replaces the CoolWorks software.

CoolWorks continues to be supported by Reliance.



We provide a range of associated products which compliments the Reliance Cool Muscle and enhance its performance, including couplings, gearboxes and linear motion components.



Reli-a-Flex® flexible shaft couplings

The Reli-a-Flex® range of one piece slit couplings has been specially designed to provide accurate transfer of motion between two rotating shafts while at the same time catering for parallel and angular misalignment as well as protecting the bearing systems. See [page 8-6](#) for more information on the Reli-a-Flex® range.



Planetary gearboxes

A range of high quality planetary gearboxes is available to suit your application needs. Combine a low backlash, zero maintenance and high durability gearhead with the Reliance Cool Muscle to maximise performance. Available in NEMA 17 and 23, ratios 3:1 to 512:1. See [page 3-3](#) for more information.

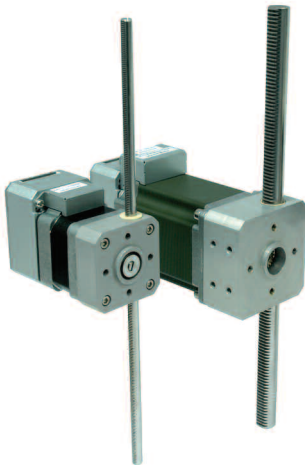

Intelligent actuator systems

A range of intelligent actuators is available to support your precision motion control needs. These include rack actuators and positioning stages for use with the Reliance Cool Muscle. Please contact us or visit the website for more information; www.reliance.co.uk/shop See [pages 2-14 to 2-23](#) for more information.

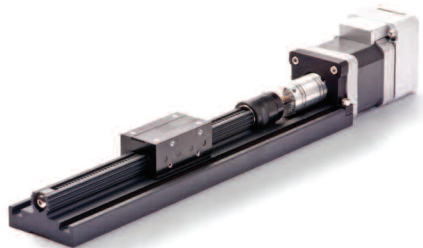



Precise, efficient linear motion

This compact actuation system combines the Reliance Cool Muscle servo system with a rack and pinion drive to give precise linear motion for high speed applications.

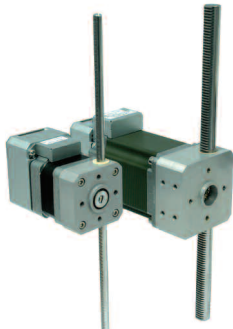

Multiple configurations are available developing peak forces up to 150 N and rated speeds of 300 mm per second, with resolutions of better than 1 micron and standby power consumption of less than 1.7 watts. The assembly has a number of different mounting options for ease of mechanical installation.

The Racktuator™ has built-in closed loop control with an integrated 32 bit CPU, magnetic encoder and PLC. This intelligent assembly can be programmed to decide for itself where it should be at any given time and to send out continuous motion data such as speed, position and torque. The unit is fully integrated, saving space and cost, and makes system integration faster and simpler with control at the point of use. The Racktuator™ is fully programmable and can store onboard discrete

positions, speeds, accelerations, timers, torque limits and custom variables, all to be recalled by up to 15 separate motion control programs. It also has built-in maths and S curve functions for advanced motion control.

Multiple Racktuators™ can work in sequence, either to produce circles, ellipses, or complex arc motions, or in a daisy chain network to automate pick-and-place machines. The Racktuator™ can be operated independently or communicate with a PC host via RS232 or USB. It can also be fitted with a traditional stepper motor, being driven by step and direction signals or with CW/CCW pulses to bring the advantages of an AC servo system to any stepper motor application.

The Racktuator™ is available with both solid and tubular racks, suitable for a variety of applications from scientific research to food preparation and packaging.

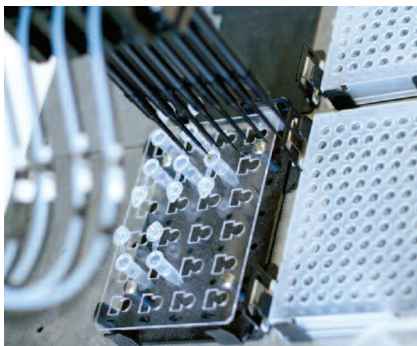

Laboratory automation



Industrial automation

Associated Products

Hardware: page 13-1

All dimensions in mm

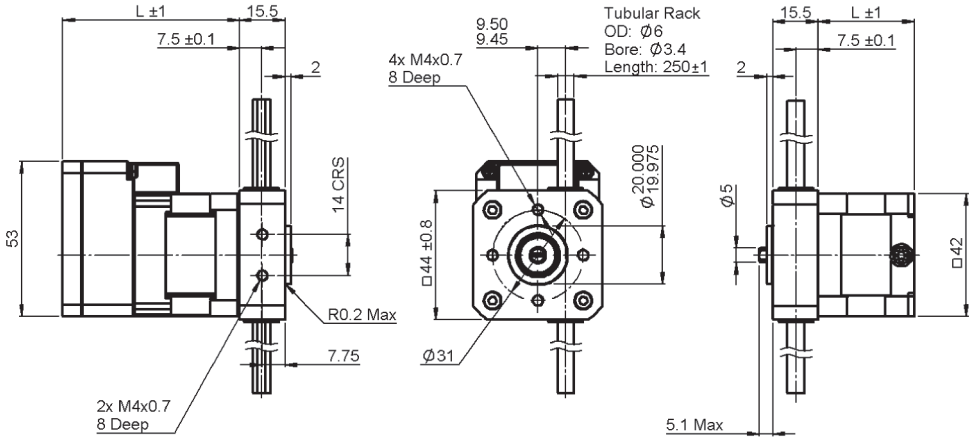

Reliance Cool Muscle Motor Option

Hybrid Stepper Motor Option

Part number selection table

Part Number	Motor	Pinion Material	L	Axial Load (N)	Momentary Load (N)	Travel Range (mm)
RCMRA17S-6-250-C	Reliance Cool Muscle Motor ¹	PEEK	60.5	3	12	200
RCMRA17L-6-250-C-S		St steel	75.3	15	25	
RRA17-6-250	Hybrid Stepper Motor ²	PEEK	33.0	3	12	
RRA17-6-250-S		St steel	33.0	15	25	

¹ Reliance Cool Muscle motor option, see pages 2-6 and 2-7 for motor details (if a pulse interface is required change -C to a -P)

² Hybrid stepper motor option, see page T2-5 for motor details

Technical specification

	RCMRA17 Reliance Cool Muscle	RRA17 Hybrid Stepper
Resolution	0.00085 mm with 50,000 steps/rev	0.21 mm with 200 steps/rev
Max speed	300 mm/sec	
Temperature range	Between 0°C and 40°C	Between -20°C and +50°C
Repeatability	0.025 mm	
Side wobble (fully extended)	±0.2 mm	
Life time	5 million cycles minimum	
Wire length	N/A	200 mm
Backlash	0.08 mm linear movement	
Rack material	316 grade stainless steel	
Lubrication	St steel	PTFE based grease
	PEEK	Lubrication free, provides smooth quiet operation

Technical support

- Product overviews see page 2-2, 2-14 and 6-2
- Technical information see pages T2-9 and T6-1

All dimensions in mm

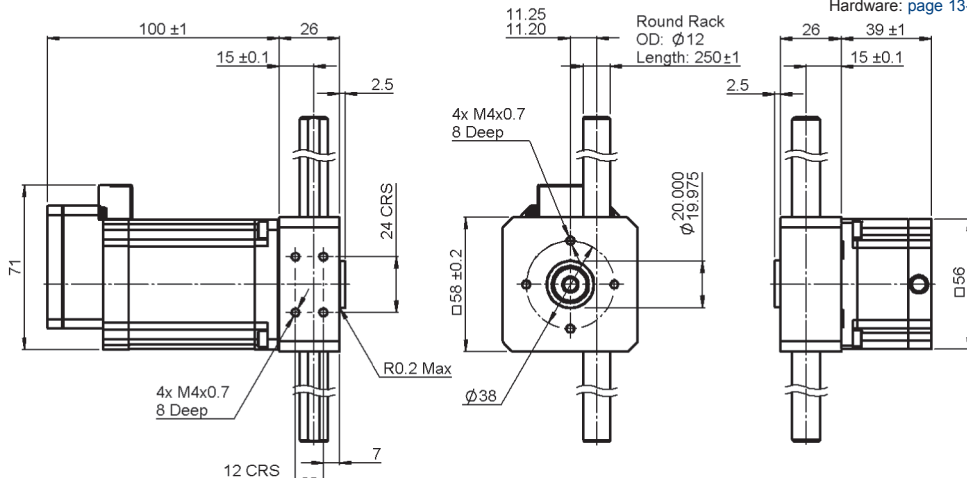

Associated Products
Hardware: page 13-1

Reliance Cool Muscle Motor Option

Hybrid Stepper Motor Option

Part number selection table

Part Number	Motor	Pinion Material	Axial Load (N)	Momentary Load (N)	Travel Range (mm)
RCMRA23L-12-250-C	Reliance Cool Muscle Motor ¹	St steel 17-4Ph coated	90	150	150
RRA23-12-250	Hybrid Stepper Motor ²		90	150	

¹ Reliance Cool Muscle motor option, see pages 2-9 for motor details (if a pulse interface is required change -C to a -P)

² Hybrid stepper motor option, see page T2-5 for motor details

Technical information

	RCMRA23 Reliance Cool Muscle	RRA23 Hybrid Stepper
Resolution	0.0008 mm with 50,000 steps/rev	0.2 mm with 200 steps/rev
Max speed	300 mm/sec	
Temperature range	Between 0°C and 40°C	Between -10°C and +50°C
Repeatability	0.012 mm	
Side wobble (50mm from housing)	±0.2 mm	
Life time	5 million cycles minimum (based on 40 mm stroke)	
Wire length	N/A	200 mm
Backlash	0.06 mm linear movement	
Rack material	440B grade stainless steel	
Lubrication	PTFE based grease	

? Technical support

- Product overviews see page 2-2, 2-14 and 6-2
- Technical information see pages T2-9 and T6-1

Associated Products

Hardware: page 13-1

All dimensions in mm

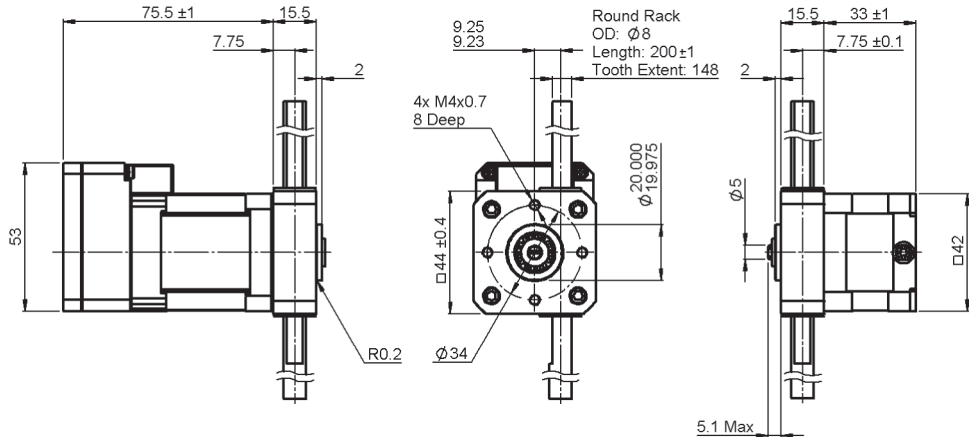

Reliance Cool Muscle Motor Option

Hybrid Stepper Motor Option

Part number selection table

Part Number	Motor	Pinion Material	Axial Load (N)	Momentary Load (N)	Travel Range (mm)
RCMRAK17L-8-200-C	Reliance Cool Muscle Motor ¹	St steel 304	25	50	100
RRAK17-8-200	Hybrid Stepper Motor ²		25	50	

¹ Reliance Cool Muscle motor option, see pages 2-7 for motor details (if a pulse interface is required change -C to a -P)

² Hybrid stepper motor option, see page T2-5 for motor details

Technical information

	RCMRAK17 Reliance Cool Muscle	RRAK17 Hybrid Stepper
Resolution	0.00075 mm with 50,000 steps/rev	0.19mm with 200 steps/rev
Max speed	500 mm/sec	
Temperature range	Between 0°C and +40°C	Between -20°C and +50°C
Repeatability	0.025 mm	
Side wobble (fully extended)	±0.29 mm	
Life time	5 million cycles minimum	
Wire length	N/A	200 mm
Backlash	0.08 mm linear movement	
Rack material	304 grade stainless steel	
Lubrication	PTFE based grease	

Technical support

- Product overviews see page 2-2, 2-14 and 6-2
- Technical information see pages T2-9 and T6-1



Providing custom-built solutions

As well as offering a range of standard actuators Reliance is able to develop bespoke solutions to suit individual requirements. Bespoke motorised actuators are based on our range of catalogue components and assemblies, together with housings and fittings manufactured by Reliance in the UK and Ireland.



XYZ theta stage

Working closely with our customers to understand the application and design specification, we are able to offer design engineering support to help develop an appropriate assembly, bringing knowledge and experience from working in a variety of industries and applications.

Typical examples shown below include a miniature motorised leadscrew actuator for a drug dispensing system, a motorised leadscrew driven slide assembly, using multiple Reliance Cool Muscle motors, for an XYZ theta position system, and a 3-axis rotary-linear actuator for a medical scanner.

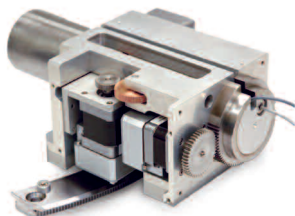

Actuator for a medical scanner

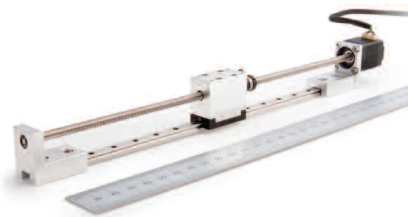

Modular linear actuator

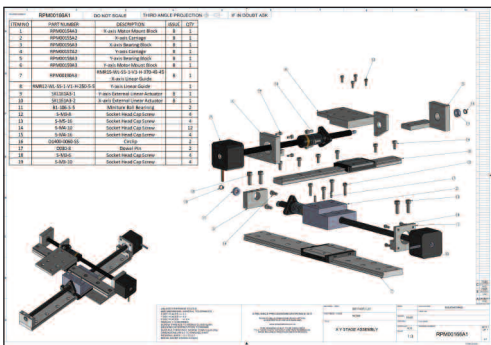

Design engineering support



Manufacturing and assembly

Intelligent Motors



Motorised leadscrew-driven linear slide

The RCMS series of leadscrew stages combines the high speeds and programmability of Reliance Cool Muscle motors with the accuracy and reliability of a leadscrew-driven linear slide.

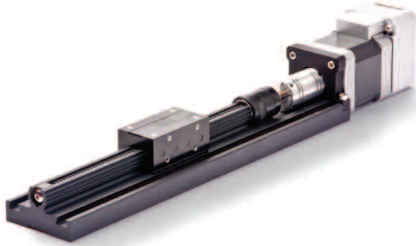

The RCMS is available with two different motor sizes and in a wide range of travel lengths and leadscrew and carriage configurations.

The precision slide's aluminium guide and carriage are driven by a rolled stainless steel leadscrew, available with metric and imperial leads. High performance polymers and TFE coating extend the life of the slide's moving parts.

The Reliance Cool Muscle motor, in NEMA sizes 17 and 23, integrates an efficient vector drive and H-infinity controller with a 50,000-count encoder to form a servo positioning system operating at speeds from 0 to 3,000 rpm with minimum power consumption. Cool Muscle's torque sensing and software travel limits give the option of eliminating home and limit switches from your system.

Typical applications for the RCMS include test instrumentation used in industrial automation and university laboratory research equipment used by the energy industry.



Test equipment for solar cell manufacture



Packaging test equipment



All dimensions in mm unless otherwise stated

Associated Products
Hardware: page 13-1

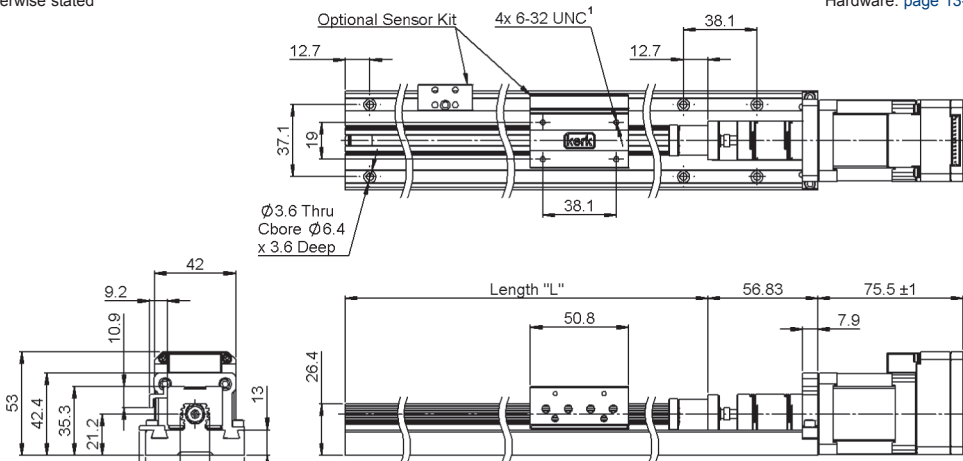

Travel distance = L - Carriage Length - Bearing Support

Length Tolerances	
< L4	± 0.1
4 < L ≤ 16	± 0.15
16 < L ≤ 63	± 0.2
63 < L ≤ 250	± 0.3

Part number selection table

Example Part No. RCMS17L-M04-C-1-18							
Basic Part Number	Screw Lead mm (Inch)	Motor Interface ²	No. Carriages ³	Linear Resolution (Default) mm	Max Drag Torque Nm	Standard Guide Lengths "L" Inch	
RCMS17L-M02	2.0	C (Computer) P (Pulse)	1	0.002	0.03	12 18	
RCMS17L-M04	4.0			0.004	0.04	12 18	
RCMS17L-M012	12.0			0.012	0.04	12 24	
RCMS17L-M25	25.0		2	0.025	0.05	18 24	
RCMS17L-0100	(0.100)			3	0.00254	0.03	10 12 15 18 24
RCMS17L-0200	(0.200)				0.00508	0.04	10 12 15 18 24
RCMS17L-0500	(0.500)		0.0127		0.04	12 15 18 24	
RCMS17L-1000	(1.000)			0.0254	0.05	12 18 24 36	

¹ Metric mounting configuration available, please enquire

² For explanation of -C and -P type interfaces, see pages 2-2 and T2-2

³ Carriage information:

1 = 1 driven carriage

2 = 1 driven and 1 passive carriage

3 = 1 driven and 2 passive carriages



Technical specification

Basic Part Number	Life @ ¼ Design Load mm	Torque to Move Carriage Design Load Nm/kg	Carriage Design Load kg	Max Linear Speed mm/sec	Axial Load kg	Screw Inertia kgm ² /m	Carriage Roll Angle Deg.
RCMS17L-M02	254x10 ⁶	0.016	16	127	5	4.2x10 ⁻⁶	1
RCMS17L-M04		0.023		254			
RCMS17L-M12		0.039		635			
RCMS17L-M25		0.070		1270			
RCMS17L-0100		0.016		127			
RCMS17L-0200		0.023		254			
RCMS17L-0500		0.039		635			
RCMS17L-1000		0.070		1270			

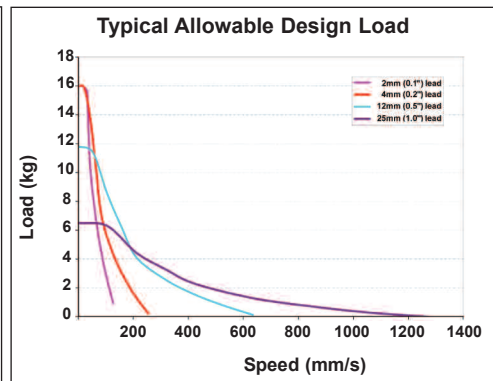
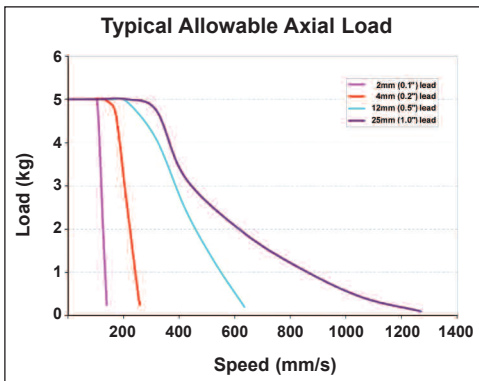

Typical RCMS Accuracy Graph

Based on 0.500 inch lead with a 3 kg load Backlash <0.003 mm

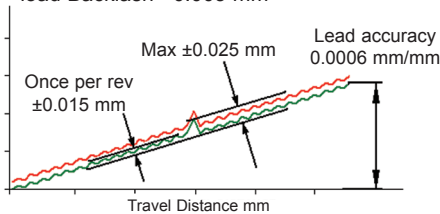

? Technical support

- Product overviews - see [page 2-19](#) and [2-2](#)
- Technical information - see [pages T2-1 to T2-8](#)

i Product options

- Special carriage, rail, screw or metric mounting configurations
- Higher accuracy leadscrew
- Left Hand (LH) or Left/Right (L/R) thread
- Metric leads and guide lengths
- Alternative guide lengths
- Sensor kits, add -S to the end of the part number e.g. [RCMS17L-M04-C-1-18-S](#)



All dimensions in mm unless otherwise stated

Associated Products
Hardware: page 13-1

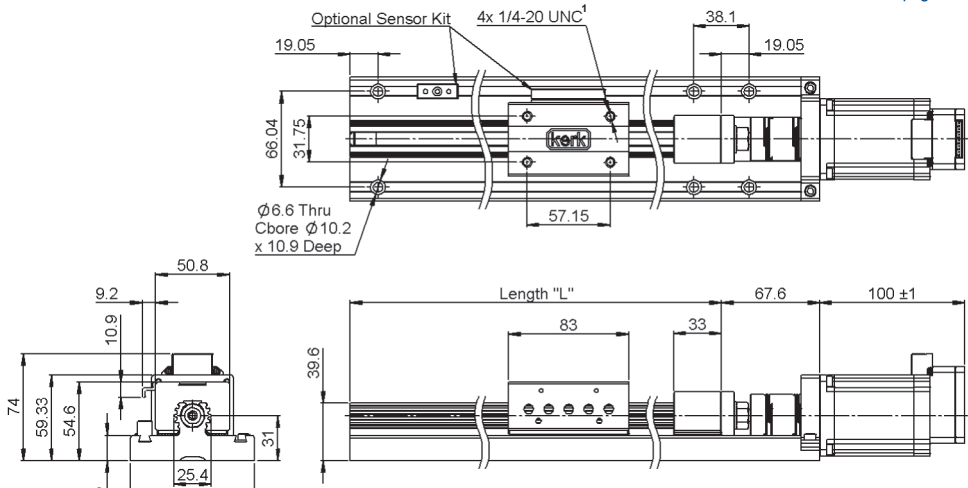

Travel distance = L - Carriage Length - Bearing Support

Length Tolerances	
< L4	± 0.1
4 < L ≤ 16	± 0.15
16 < L ≤ 63	± 0.2
63 < L ≤ 250	± 0.3

Part number selection table

Example Part No. <u>RCMS23L-M08-C-1-18</u>						
Basic Part Number	Screw Lead mm (Inch)	Motor Interface ²	No. Carriages ³	Linear Resolution (Default) mm	Max Drag Torque Nm	Standard Guide Lengths "L" (Inch)
RCMS23L-M08	8.0	C (Computer)	1	0.0080	0.04	18 24
RCMS23L-0100	(0.100)			0.00254	0.04	12 18 24 36
RCMS23L-0200	(0.200)	P (Pulse)	2	0.00508	0.04	12 18 24 36
RCMS23L-0500	(0.500)			0.0127	0.05	12 18 24 36
RCMS23L-1000	(1.000)			0.0254	0.06	12 18 24 36

¹ Metric mounting configuration available, please enquire

² For explanation of -C and -P type interfaces, see pages 2-2 and T2-2

³ Carriage information:

- 1 = 1 driven carriage
- 2 = 1 driven and 1 passive carriage
- 3 = 1 driven and 2 passive carriages



Technical information

Basic Part Number	Life @ ¼ Design Load mm	Torque to Move Carriage Design Load Nm/kg	Carriage Design Load kg	Max Linear Speed mm/sec	Axial Load kg	Screw Inertia kgm ² /m	Carriage Roll Angle Deg.
RCMS23L-M08	254x10 ⁶	0.038	46	267	14	3.9x10 ⁻⁵	1
RCMS23L-0100		0.020		85			
RCMS23L-0200		0.031		169			
RCMS23L-0500		0.047		423			
RCMS23L-1000		0.101		847			

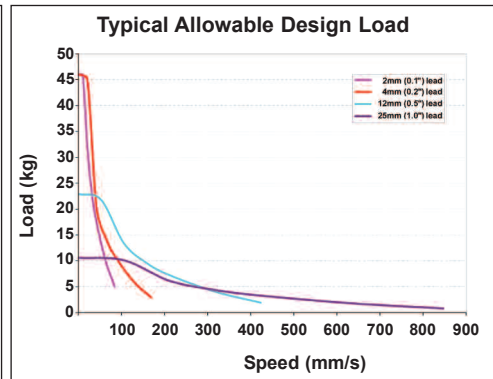
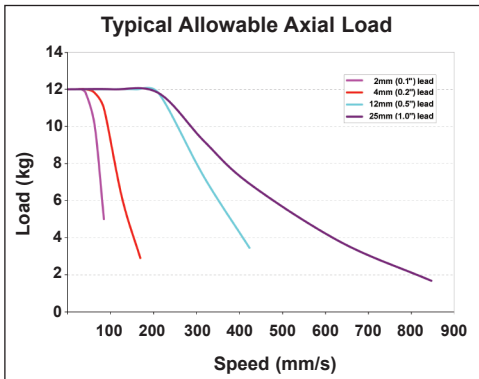

Typical RCMS Accuracy Graph

Based on 0.500 inch lead with a 3 kg load Backlash <0.003 mm

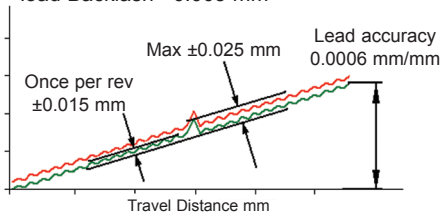

? Technical support

- Products overview - see [page 2-19](#) and [2-2](#)
- Technical information - see [pages T2-1 to T2-8](#)

i Product options

- Special carriage, rail, screw or metric mounting configurations
- Higher accuracy leadscrew
- Left Hand (LH) or Left/Right (L/R) thread
- Metric leads and guide lengths
- Alternative guide lengths
- Sensor kits, add -S to the end of the part number e.g. [RCMS17L-M04-C-1-18-S](#)

Hybrid linear actuators

Reliance offers a range of low maintenance hybrid linear actuators for equipment designers who require high performance and exceptional endurance in a very small package. The actuators are engineered with custom thermoplastics in the rotor drive nut and a stainless steel leadscrew. This allows the linear actuator to be quieter, more efficient and more durable than the standard acme thread and bronze nut configuration commonly used in other linear actuators.

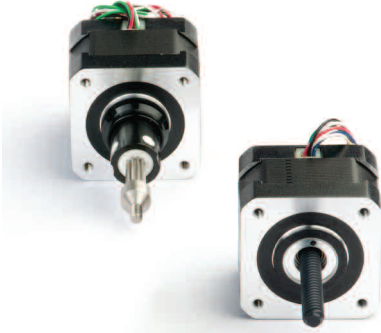

The hybrid linear actuators are available in NEMA frame sizes 8 to 34, with up to 400 full steps per revolution and travel increments as small as 0.003 mm/step.

There are three configurations:

- captive shaft
- non-captive linear
- external linear

Captive linear actuators offer a short stroke in a compact package where anti-rotation of the shaft is not possible by any other means. These units convert rotary to linear motion via an integrated leadscrew and nut. The integrated leadscrew is held captive within the motor housing, welded to a stainless steel spline arrangement. This provides anti-rotation of the leadscrew enabling precise linear movement.

The non-captive linear actuator leadscrew travels through the motor giving an extremely short footprint. As with the captive shaft actuator, conversion of rotary to linear motion takes place within the motor itself by means of the integrated leadscrew and nut, therefore eliminating the use of belts and pulleys, couplings and other mechanical transmission components.

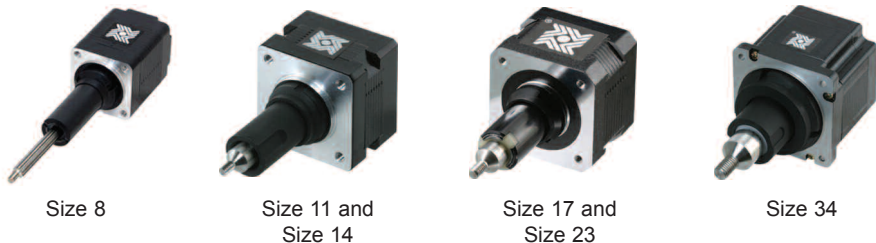

Size 8

Size 11 and
Size 14

Size 17 and
Size 23

Size 34

External linear actuators combine conventional leadscrew and nut technology with stepper motor technology. The leadscrew forms part of the motor shaft negating the need for a shaft to shaft coupling, thus providing zero transmission error from motor to screw and shortening the overall linear footprint.

Contact us for details of products and specifications.



Can-Stack linear actuators



For volume applications we also offer Can-Stack linear actuators, which are a threaded rotor in conjunction with a leadscrew shaft to provide rapid linear movement in two directions (inward and outward). They are available in captive shaft, non-captive linear or external linear variants.

Unique features give ruggedness and reliability that assure long life and consistent performance. Rare earth magnets are available for even higher thrust. The actuators are built with dual ball bearings for greater motion control, precise step accuracy and long life.

Applications for the Can-Stack linear actuators include medical instrumentation, machinery automation, robotics and other automated devices which require precise, remote controlled linear movement in a broad range of temperature environments, whilst the hybrid linear actuators are ideal for applications requiring precise positioning, rapid motion and long life, including XY tables, medical equipment and semi-conductor handling equipment.



Micro dispensing syringe drive



Pharmaceutical testing equipment

Customised configurations

In addition to standard configurations the actuators can be modified to meet specific application requirements. Reliance's applications engineering experience, manufacturing and assembly capabilities enable us to provide modified products and bespoke assembly solutions, see [page 2-18](#).

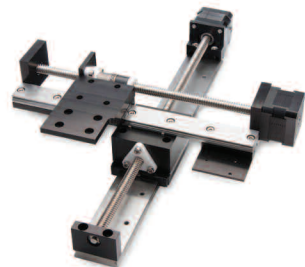



Linear rail actuators

The linear rail actuator consists of a stationary base and load bearing carriage that travels along a rigid extruded aluminium rail, together with a single stack size 17 stepper motor.



The carriage design is unique; it controls slide bearing play with a self-adjusting linear bearing. Integrated along the entire length rail system are “T” slots allowing mounting of limit switches and sensors.

The leadscrew is made from 303 stainless steel with a Black Ice™ TFE coating for durable and permanent lubrication.

The features of the linear rail actuator include:

- “T” slots integrated into exterior rail bottom and sides that accommodate full length support and various mounting options
- Loads easily attach to the compact, moving carriage with four or six M4 x 0.7 size screws
- Load bearing carriage moves efficiently and smoothly within the internal rail geometry of this specially designed aluminum extrusion
- Rail provides end-to-end axial stability and precise motion system accuracy
- Automatic adjustments of slide bearing play with a patent pending “anti-backlash” linear bearing
- Rated life equals that of the existing leadscrews of similar size
- Leadscrew end configurations adapt to various rotary motion sources
- Black Ice™ TFE coatings on a 303 stainless steel leadscrew

For optimum performance, the system can be fitted with the Size 17 Hybrid Linear Actuator, see [page 2-24](#) available in a wide variety of resolutions - from 0.001524 mm/step to 0.048768 mm/step, delivering thrust of up to 222 N. For greater performance Size 17 Hybrid Double Stack Linear actuators provide 0.0158mm/step to 0.127 mm/step and deliver thrust of up to 337N.

Load ratings

	RLRW04
Top load (Z direction)	225 N
Overhang	225 N
Moment roll	8.5 Nm
Moment yaw	8.5 Nm
Moment pitch	8.5 Nm
Twist	±0.75°/m

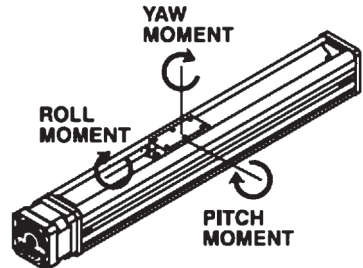



Associated Products
Hardware: page 13-1

All dimensions in mm
unless otherwise stated

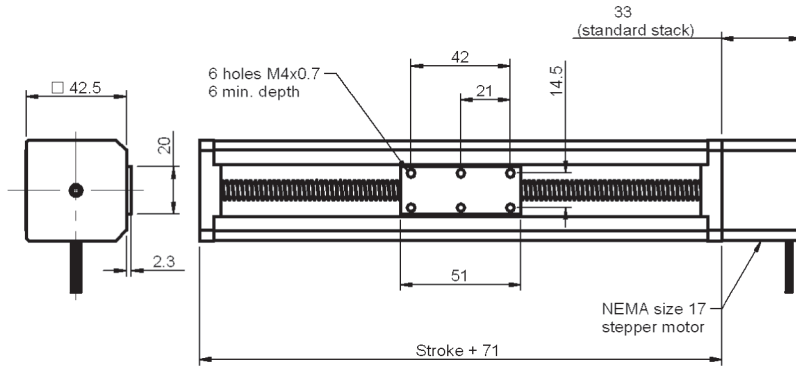

Part number selection table

Example Part No. RLRW04 - B - R⁽²⁾ - M⁽³⁾ - 43⁽⁴⁾ - 0025 - 12								
Basic Part Number	Screw Coating ⁽¹⁾	Performance Specifications			Thread Code	Lead (mm)	Lead (inch)	Stroke ⁽⁵⁾ Rounded Up (inch)
		Max Stroke Length (mm)	Max Speed (m/sec)	Straight Line Accuracy (mm/m)				
RLRW04	B (Black Ice™) S (Uncoated) N (No screw)	1,000	0.5	±1.0	0025	0.635	0.025	07 = 7in 08 = 8in 12 = 12in
					0031	0.794	0.03125	
					0039	1.0	0.0394	
					0050	1.27	0.05	
					0063	1.588	0.0625	
					0079	2.0	0.0787	
					0100	2.54	0.1	
					0125	3.175	0.125	
					0197	5.0	0.1969	
					0250	6.35	0.25	
					0394	10.0	0.3937	
					0500	12.70	0.5	
0750	19.05	0.75						
1000	25.40	1.0						

⁽¹⁾ Alternative screw coatings available, please contact our sales team for more information

⁽²⁾ R = right handed, L = left handed, N = no screw

⁽³⁾ M = motorised

⁽⁴⁾ Size 17 stepper motor

⁽⁵⁾ Stroke length in inches and will be rounded up. Maximum length 24 inch

Intelligent Motors



Introducing the motorised leadscrew linear slide range

Reliance offers a range of motorised actuator systems including the motorised leadscrew linear slide. It offers exceptional linear speed, accurate positioning, and long life in a compact assembly. One of its many advantages is that the length and speed are not limited by critical screw speed, allowing high RPM and linear speeds, even over long spans. Lengths up to 2.4 metres can readily be built, and longer lengths are possible on a special order basis.

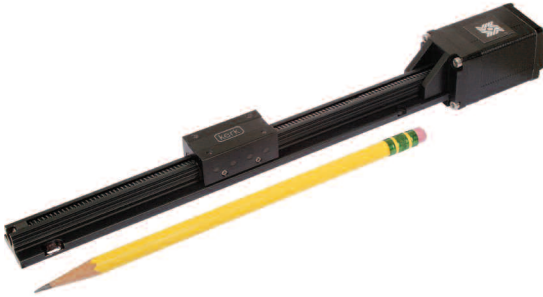

The motorised leadscrew linear slide features wear-compensating, anti-backlash carriages to ensure repeatable and accurate positioning. The pre-assembled unit combines a screw-driven linear actuator with an integrated stepper motor drive reducing part count and improving system integration.

It is available in standard and wide base options, each capable of supporting a range of load capacities. There are four variants of the standard base supporting 67 N, 156 N, 222 N and 445 N, and two of the wide base to support 156 N and 445 N. Both are available with a right or left hand thread; the nominal thread leads are shown in the table opposite. The stepper motor is available in three sizes - NEMA size 11, 17 and 23, alternatively the actuator can be supplied integrated with the Reliance Cool Muscle motor, see [pages 2-19 to 2-23](#), or as a non-motorised leadscrew linear slide see [page 7-38](#).

Typical considerations when selecting a linear actuator include:

- How much force is required from the linear actuator?
- What is the duty cycle of the linear move?
- What is desired step increment from the linear actuator?
- What is the step rate or speed of travel?
- Bipolar or unipolar coils in the stepper motor prime mover?
- Stepper motor coil voltage?
- Must the lead screw hold position with power off or must it be "backdrivable" with power off?
- Are there size restrictions (max footprint of the linear actuator)?
- What is the anticipated life requirement?
- Temperature of operating environment?



Please contact us to discuss your requirements.



Product selection table

Nominal Thread Lead Inches mm		Standard Base Option				Wide Base Option	
		Standard 1	Standard 2	Standard 3	Standard 4	Wide 1	Wide 2
		67 N	156 N	222 N	445 N	156 N	445 N
		Size 11DS Size 17SS Size 17DS	Size 17SS Size 17DS Size 23SS Size 23DS	Size 23SS Size 23DS	Size 23SS Size 23DS	Size 17SS Size 17DS Size 23SS Size 23DS	Size 23SS Size 23DS
0.025	0.635	•					
0.039	1.00	•					
0.050	1.27	•	•			•	
0.0625	1.59	•					
0.079	2.00	•	•			•	
0.098	2.50			•			
0.100	2.54	•	•	•	•	•	•
0.118	3.00	•					
0.125	3.18				•		•
0.157	4.00		•			•	
0.197	5.00		•	•		•	
0.200	5.08	•	•	•	•	•	•
0.250	6.35	•	•		•	•	•
0.315	8.00				•		•
0.375	9.53		•			•	
0.394	10.00	•					
0.400	10.16		•			•	
0.472	12.00		•			•	
0.500	12.70	•	•	•	•	•	•
0.630	16.00			•	•		•
0.750	19.05	•	•			•	
0.984	25.00		•			•	
1.000	25.40		•	•	•	•	•
1.200	30.48		•			•	
1.500	38.10				•		•
2.000	50.80				•		•

Notes

The wide base option provides parallel guide tracks for traversing sensor mount devices

SS = Single Stack, standard linear actuator stepper motor

DS = Double Stack, hybrid linear actuator stepper motor

For further information regarding the single and double stack motors, please contact us

Intelligent Motors

Systems Overview	1
Intelligent Motors and Motorised Actuators	2
Planetary and Right Angle Gearboxes	3
Brass, Ground and Precision Spur Gears	4
Worms and Wheels, Bevels and Internal Gears	5
Round and Rectangular Racks and Pinions	6
Leadscrews and Leadscrew Assemblies	7
Flexible Shaft Couplings, Clutches and Collars	8
Linear Guides and Slides	9
Belts and Pulleys	10
Gear Clamps and Accessories	11
Bearings and Spacers	12
Machine Screws, Dowel Pins and Hardware	13
Technical Information	14

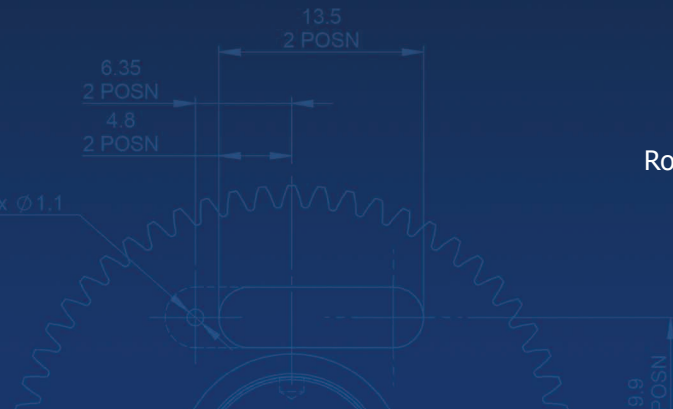

Rowley Mills, Penistone Road, Lepton
Huddersfield, HD8 0LE, England

+44 (0) 1484 601002
www.reliance.co.uk
sales@reliance.co.uk