



All dimensions in mm

Associated Products

Planetary Gearboxes: [page 3-3](#)

Couplings: [page 8-1](#)

Leadscrews: [page 7-1](#)

Hardware: [page 13-1](#)

Cables: [page 2-11](#)

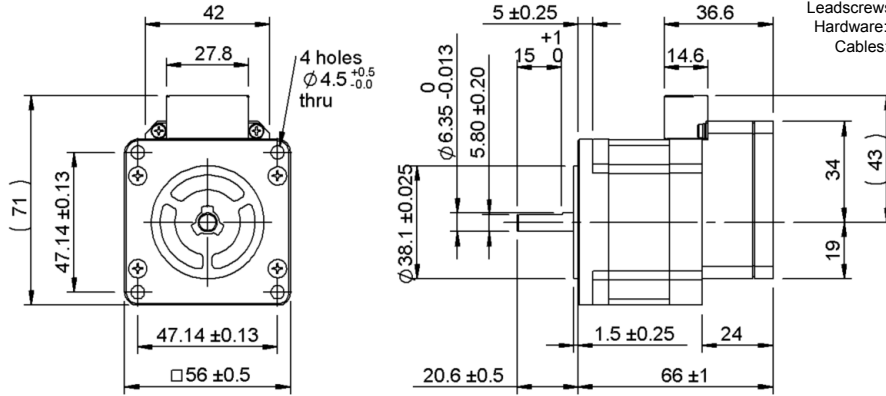

RCM1 - P - 23 S 30-C - RT3

Generation
Interface P = Pulse
C = Computer
Speed 30 = 3000 rpm

Specification table

	RCM1- □ -23S30-C-RT3
Motor output power	45 W
Maximum speed	3,000 rpm
Continuous torque	0.29 Nm
Peak torque	0.42 Nm
Load inertia allowance	1.0x10 ³ g-cm ²
Motor inertia	1.0x10 ² g-cm ²
Input supply current rated (Continuous torque/rated peak torque)	3.9 A/5.1 A
Weight	580 g

Torque curve

RCM1- □ -23S30-C-RT3

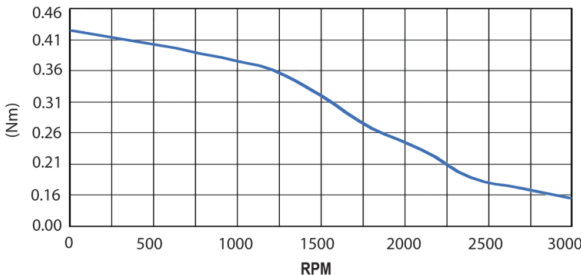

? Technical support

- Product overview - see [page 2-2](#)
- Technical information - see [page T2-1](#)
- P & C interface - see [page T2-2](#)
- Software interface - see [page T2-3](#)
- Electrical interface - see [page T2-5](#)
- Cables - see [page 2-11](#)
- Accessories - see [page 2-12](#)