

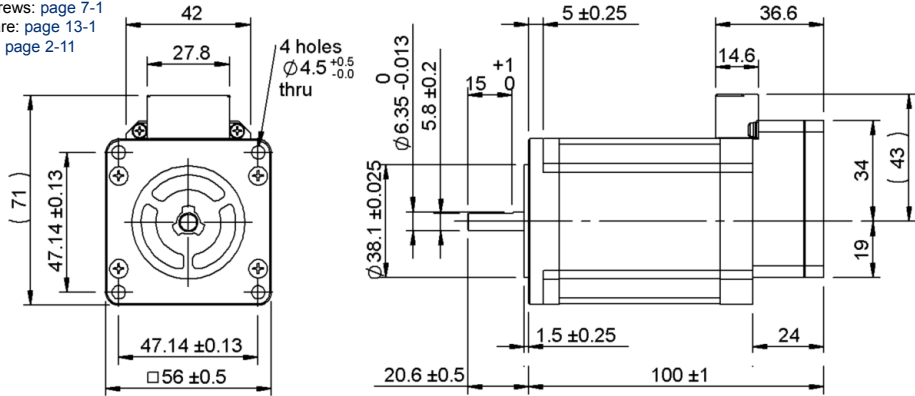

Associated Products

- Planetary Gearboxes: page 3-3
- Couplings: page 8-1
- Leadscrews: page 7-1
- Hardware: page 13-1
- Cables: page 2-11

All dimensions in mm



RCM1 - P - 23 L 20-C - RT3

Generation
Interface
P = Pulse
C = Computer
Speed
20 = 2000 rpm

Specification table

	RCM1- □ -23L20-C-RT3
Motor output power	30 W
Maximum speed	2,000 rpm
Continuous torque	0.87 Nm
Peak torque	1.24 Nm
Load inertia allowance	3.6x10 ³ g-cm ²
Motor inertia	3.6x10 ² g-cm ²
Input supply current rated (Continuous torque/rated peak torque)	2.6 A/3.4 A
Weight	1100 g

Torque curve

RCM1- □ -23L20-C-RT3

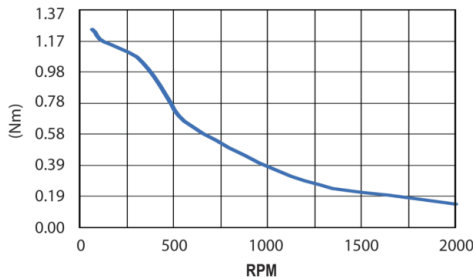

? Technical support

- Product overview - see [page 2-2](#)
- Technical information - see [page T2-1](#)
- P & C interface - see [page T2-2](#)
- Software interface - see [page T2-3](#)
- Electrical interface - see [page T2-5](#)
- Cables - see [page 2-11](#)
- Accessories - see [page 2-12](#)

Intelligent Motors