



Abbey House, Charter Street, Leicester. LE13UD

Tel: 0116 242 5425. Fax: 0116 242 5555

Email: sales@flowmech.co.uk www.flowmech.co.uk

OPERATIONS AND MAINTENANCE MANUAL

FC Booster Set with PM2AD Controller

Please fulfil all listed requirements prior to and during installation and operation of all equipment to prevent invalidation of any warranty given.

Description of Equipment

The "FC" range of single pump booster sets are designed for small water supply systems feeding taps and solenoids in homes garages, car washers

Original installation and operating instructions.

CONTENTS

	Page
1. Symbols used in this document	6
2. Applications	6
2.1 Liquids	6
2.2 Liquid temperature	6
2.3 Operating pressure	6
3. Installation	6
3.1 Location	7
4. Electrical connection	8
4.1 Connecting units with cable and plug fitted	8
4.2 Connecting units with no cable and plug fitted	8
4.3 Alternative power supply	8
5. Control panel	9
5.1 DIP switches	10
5.2 Enabling the DIP switch settings	11
5.3 Checking the DIP switch settings	11
6. Start-up	11
7. Operation	11
7.1 Start/stop according to water consumption	11
7.2 Start/stop with 1 bar differential pressure	11
7.3 Power supply failure	12
8. Functions	12
8.1 Auto-reset	12
8.2 Anti-cycling	12
8.3 Maximum continuous operating time (30 minutes)	12
8.4 Dry-running protection	12
9. Frost protection	13
10. List of alarms	13
11. Technical data	14
12. Fault finding chart	15
13. Further product information	16
14. Disposal	16



Warning

Prior to installation, read these installation and operating instructions. Installation and operation must comply with local regulations and accepted codes of good practice.

1. Symbols used in this document



Warning

If these safety instructions are not observed, it may result in personal injury!



If these safety instructions are not observed, it may result in malfunction or damage to the equipment!



Notes or instructions that make the job easier and ensure safe operation.

2. Applications

The Grundfos PM 2 is designed for automatic start/stop control of Grundfos pumps and other pumps for water supply. The PM 2 can be installed in systems with or without a pressure tank.

Typical applications are water supply systems and rainwater systems in

- single-family houses
- blocks of flats
- summer houses and holiday cottages
- horticulture and gardening
- agriculture.

2.1 Liquids

Clean, thin, non-aggressive and non-explosive liquids without solid particles or fibres that may attack the unit mechanically or chemically.

Examples:

- drinking water
- rainwater.

2.2 Liquid temperature

0 °C - see nameplate.

2.3 Operating pressure

Max. 10 bar.

3. Installation

Install the unit on the discharge side of the pump. See fig. 2.

If pumping from a well, borehole or similar, always fit a non-return valve on the suction pipe of the pump.

It is recommended to connect the unit to the piping system using unions.

The outlet connection of the unit can be rotated 360°. See fig. 1.

The inlet connection is an integrated part of the unit housing.

The unit has a built-in non-return valve.

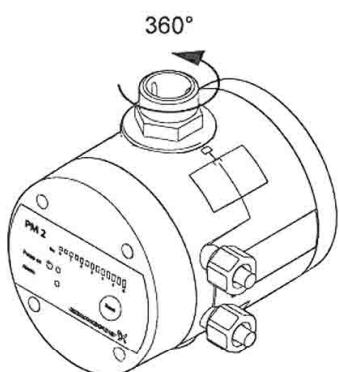

Fig. 1 Rotary outlet connection

3.1 Location

The installation location must be clean and well ventilated.

The PM 2 must be positioned so that it is protected from rain and direct sunlight.

The PM 2 can be installed in systems with or without a pressure tank. See fig. 2.

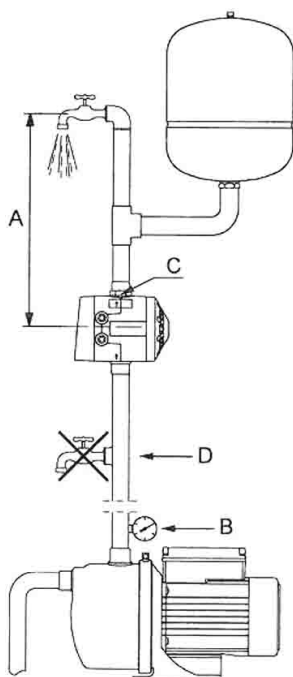

Fig. 2 Installation example

The unit can be fitted directly to the pump discharge port or between the pump and the first tapping point.

TM03 9707 1508

TM04 0336 1508

Pos. A in fig. 2:

It is recommended to install the unit so that the height between the unit and the highest tapping point does not exceed the values in the table below.

Start pressure set [bar]	Maximum height [m]
1.5*	11
2.0	16
2.5	21
3.0	26
3.5	31
4.0	36
4.5	41
5.0	46

* Default setting.

See section 7.1 Start/stop according to water consumption.

Pos. B in fig. 2:

To achieve correct operation, the pump should at least be able to provide the discharge pressures in the table below.

Minimum discharge pressure

Start pressure set [bar]	Operating mode	
	Start/stop according to water consumption*	Start/stop with 1 bar differential pressure**
1.5*	1.9	2.9
2.0	2.4	3.4
2.5	2.9	3.9
3.0	3.4	4.4
3.5	3.9	4.9
4.0	4.4	5.4
4.5	4.9	5.9
5.0	5.4	6.4

* Default setting.

See section 7.1 Start/stop according to water consumption.

** See section 7.2 Start/stop with 1 bar differential pressure.

Pos. C in fig. 2:

The unit should be installed so that the control panel is visible and easily accessible. Ensure that the inlet and outlet are connected correctly.

Caution

To prevent water from entering the unit, do not install the unit so that the cable connections are pointing upwards. See fig. 3.

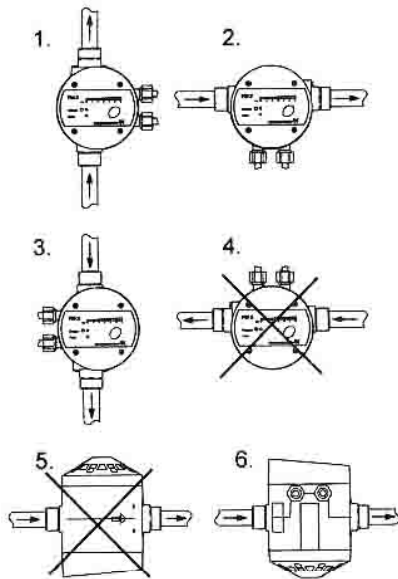

Fig. 3 Mounting positions

Caution

Mounting position 6 should be avoided if the pumped liquid contains particles as these may settle inside the internal pressure tank of the unit.

It is possible to loosen the control panel and change its position, depending on the mounting position of the unit. See fig. 4.

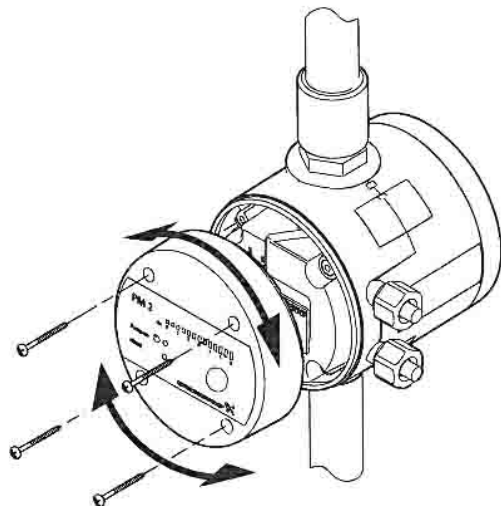

Fig. 4 Orientation of the control panel

4. Electrical connection

Warning

The electrical connection must be carried out in accordance with local regulations and standards.

Before making any connections in the unit, make sure that the power supply has been switched off and that it cannot be accidentally switched on.



The unit must be connected to an external mains switch with a contact gap of at least 3 mm in all poles.

As a precaution, the unit must be connected to a socket with earth connection.

It is recommended to fit the permanent installation with an earth leakage circuit breaker (ELCB) with a tripping current < 30 mA.

4.1 Connecting units with cable and plug fitted

Connect the unit using the supplied cable.

4.2 Connecting units with no cable and plug fitted

1. Remove the control panel of the unit.
2. Carry out the electrical connection as shown in fig. A or B, page 212, depending on motor type.
3. Fit the control panel securely with all four mounting screws so that enclosure class IP65 is maintained.

4.3 Alternative power supply

The PM 2 can be powered by a generator or other alternative power supplies, provided that the requirements for the power supply are fulfilled. See section 11. *Technical data.*

TM04 1950 1708

TM04 1951 1508

4. Electrical connection

Warning

The electrical connection must be carried out in accordance with local regulations and standards.

Before making any connections in the unit, make sure that the power supply has been switched off and that it cannot be accidentally switched on.



The unit must be connected to an external mains switch with a contact gap of at least 3 mm in all poles.

As a precaution, the unit must be connected to a socket with earth connection.

It is recommended to fit the permanent installation with an earth leakage circuit breaker (ELCB) with a tripping current < 30 mA.

4.1 Connecting units with cable and plug fitted

Connect the unit using the supplied cable.

4.2 Connecting units with no cable and plug fitted

1. Remove the control panel of the unit.
2. Carry out the electrical connection as shown in fig. A or B, page 212, depending on motor type.
3. Fit the control panel securely with all four mounting screws so that enclosure class IP65 is maintained.

4.3 Alternative power supply

The PM 2 can be powered by a generator or other alternative power supplies, provided that the requirements for the power supply are fulfilled. See section 11. *Technical data*.

5. Control panel

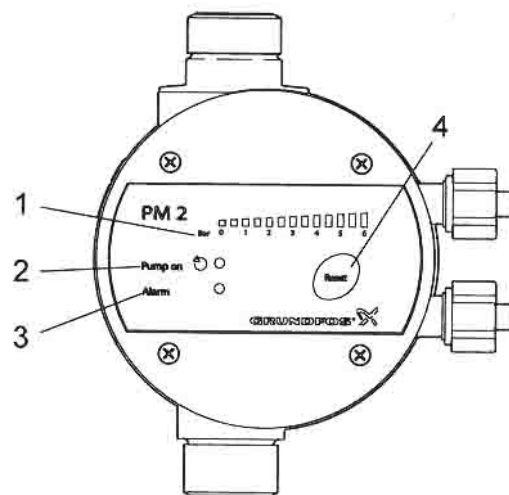

Fig. 5 Control panel

TM03 9361 1508

Pos.	Description	Function
1	"Pressure scale"	The pressure scale has 13 light fields indicating the pressure from 0 to 6 bar. All light fields illuminate briefly when the power supply is switched on.
2	"Pump on"	The green indicator light is permanently on when the pump is running. The indicator light also illuminates briefly when the power supply is switched on.
3	"Alarm"	The red indicator light is permanently on or flashes when the pump has stopped due to an operating fault. See section 12. <i>Fault finding chart</i> . The indicator light also illuminates briefly when the power supply is switched on.
4	[Reset]	The button is used for <ul style="list-style-type: none"> • resetting of fault indications • checking of DIP switch settings. See section 5.3 <i>Checking the DIP switch settings</i> .

5.1 DIP switches

The PM 2 has a number of settings which can be made with the DIP switches behind the control panel. See fig. 6.



Fig. 6 DIP switches

DIP switch		Description	Default setting
No.	Name		
1-4	START	<p>Start pressure (p_{start}) With these DIP switches the start pressure can be set from 1.5 to 5.0 bar in steps of 0.5 bar.</p> <p>Example: DIP switch 1 = "ON" DIP switch 2 = "ON" Start pressure = $1.5 + 0.5 + 1 = 3$ bar See section 7.2.1 <i>Starting and stopping conditions</i>.</p>	All set to OFF ($p_{start} = 1.5$ bar)
5	STOP = START + 1 BAR	<p>Start/stop with 1 bar differential pressure (This operating mode is only suitable for systems with a pressure tank). When the DIP switch has been set to "ON", the pump stop pressure will be equal to $p_{start} + 1$ bar. See section 7.2 <i>Start/stop with 1 bar differential pressure</i>. In systems without a pressure tank, the DIP switch must be set to "OFF".</p>	OFF (start/stop according to water consumption)
6	AUTO RESET	<p>Automatic resetting of alarms When the DIP switch has been set to "ON", the cycling and dry-running alarms will automatically be reset if they have been activated. See section 8.1 <i>Auto-reset</i>.</p>	OFF (manual resetting)
7	ANTI CYCLING	<p>Anti-cycling When the DIP switch has been set to "ON", the pump will be stopped in case of cycling. See section 8.2 <i>Anti-cycling</i>.</p>	OFF
8	MAX RUN 30 MIN.	<p>Maximum continuous operating time (30 minutes) When the DIP switch has been set to "ON", the pump will automatically be stopped if it has been running continuously for 30 minutes. See section 8.3 <i>Maximum continuous operating time (30 minutes)</i>.</p>	OFF

5.2 Enabling the DIP switch settings

Note

When the desired DIP switch settings have been made, they must be enabled, otherwise the PM 2 cannot detect the settings.

To enable the DIP switch settings, press [Reset] or disconnect and reconnect the power supply to the unit.

5.3 Checking the DIP switch settings

When [Reset] is kept pressed for at least 3 seconds, the light fields for the DIP switches set to "ON" will illuminate in the pressure scale.

The light fields illuminate from right to left. This means that if the light field to the far right is on, DIP switch 8 has been set to "ON", etc. See the table below.

Light field [bar]	2.5	3.0	3.5	4.0	4.5	5.0	5.5	6.0
DIP switch no.	1	2	3	4	5	6	7	8

6. Start-up

1. Open a tap in the system.
2. Switch on the power supply.
3. Check that the "Pump on" and "Alarm" indicator lights as well as all the green light fields in the pressure scale illuminate briefly.
 - The pump is running, and a pressure will be built up in the system. The pressure is indicated by the light fields in the pressure scale.
4. Close the tap.
5. Check that the pump stops after a few seconds and that the "Pump on" indicator light goes out.

The system is now ready for operation.

If a pressure is not built up in the system within 5 minutes after start-up, the dry-running protection will be activated, and the pump is stopped. Check the priming conditions of the pump before attempting to restart the pump.

Note

The pump is restarted automatically if DIP switch 6 (AUTO RESET) has been set to "ON", otherwise the pump can be restarted manually by pressing [Reset].

7. Operation

The PM 2 automatically starts and stops the pump. This can be achieved in two different ways:

- On delivery, the unit has a default setting which can be used in systems with or without a pressure tank. See section 7.1 *Start/stop according to water consumption*.
- In systems with a pressure tank, it is possible to use the setting described in section 7.2 *Start/stop with 1 bar differential pressure*. This setting will reduce the pump operating time.

7.1 Start/stop according to water consumption

As default, the PM 2 is set to this operating mode, i.e. DIP switch 5 set to "OFF".

Caution

With the default setting the pump will not stop until it reaches its maximum pressure.

7.1.1 Starting and stopping conditions

Starting conditions

The unit starts the pump when at least one of the following conditions is fulfilled:

- The flow is higher than $Q_{min.}$
- The pressure is lower than p_{start} .
The default start pressure is 1.5 bar and can be increased in steps of 0.5 bar. See section 5.1 *DIP switches*.

Stopping conditions

The unit stops the pump with a time delay of 10 seconds when the following conditions are both fulfilled:

- The flow is lower than $Q_{min.}$
- The pressure is higher than p_{start} .

The p_{start} and $Q_{min.}$ values are shown in section 11. *Technical data*.

7.2 Start/stop with 1 bar differential pressure

This operating mode can be used in systems with a pressure tank of a sufficient size.

In this operating mode, the pump is started and stopped at a 1 bar differential pressure, which reduces the pump operating time. If the pressure tank is of an insufficient size, it will cause cycling of the pump.

To enable this operating mode, set DIP switch 5 to "ON". See section 5.1 *DIP switches*.

7.2.1 Starting and stopping conditions

The conditions described below require that DIP switch 5 has been set to "ON".

Starting conditions

The unit starts the pump when the pressure is lower than p_{start} .

The default start pressure is 1.5 bar and can be increased in steps of 0.5 bar. See section 5.1 *DIP switches*.

Stopping conditions

The unit stops the pump when the pressure is higher than p_{stop} .

$p_{stop} = p_{start} + 1 \text{ bar}$.

7.3 Power supply failure

In case of a power supply failure, the pump restarts automatically when power returns and runs for at least 10 seconds.

8. Functions

8.1 Auto-reset

When the auto-reset function is enabled, cycling and dry-running alarms will be automatically reset.

To enable the function, set DIP switch 6 to "ON". See section 5.1 *DIP switches*.

The auto-reset function should NOT be enabled on pumps which cannot self-prime when water returns after dry-running.

Caution

8.2 Anti-cycling

To avoid inadvertent starts and stops of the pump in case of a failure in the installation, the anti-cycling function can be enabled.

The function will detect cycling if it occurs and stop the pump with an alarm.

When the PM 2 has been set to start/stop according to water consumption, cycling may occur in the following situations:

- In case of a minor leakage.
- If a tap has not been entirely closed.

When the PM 2 has been set to start/stop with 1 bar differential pressure, cycling may occur in the following situations:

- If the pressure tank has lost its precharge pressure.
- If the size of the pressure tank is insufficient.

If the cycling alarm has been activated, the pump can be restarted manually by pressing [Reset].

When the auto-reset function is enabled, the pump will be restarted automatically after 12 hours in alarm condition.

To enable the function, set DIP switch 7 to "ON". See section 5.1 *DIP switches*.

In case of a very small consumption, the anti-cycling function may register this as a minor leakage and stop the pump inadvertently. If this occurs, the function can be disabled.

Note

8.3 Maximum continuous operating time (30 minutes)

When this function is enabled, the pump will be stopped when the pump has been running continuously for 30 minutes.

Restart the pump by pressing [Reset].

The purpose of this function is to avoid unnecessary water and current consumption, e.g. in case of pipe fracture or considerable leakages.

When the function is enabled, any consumption exceeding 30 minutes will cause an alarm, and the pump will be stopped.

Note

If enabled, the auto-reset function will not restart the pump.

To enable the function, set DIP switch 8 to "ON". See section 5.1 *DIP switches*.

8.4 Dry-running protection

The unit incorporates dry-running protection that automatically stops the pump in case of dry running. The dry-running protection functions differently during priming and operation.

If a dry-running alarm has been activated, the cause should be found before the pump is restarted in order to prevent damage to the pump.

Caution

8.4.1 Dry running during priming

If the unit detects no pressure and no flow within 5 minutes after it has been connected to a power supply and the pump has started, the dry-running alarm is activated.

8.4.2 Dry running during operation

If the unit detects no pressure and no flow within 40 seconds during normal operation, the dry-running alarm is activated.

8.4.3 Resetting of dry-running alarm

Manual resetting

If a dry-running alarm has been activated, the pump can be restarted manually by pressing [Reset]. If the unit detects no pressure and no flow within 40 seconds after restarting, the dry-running alarm is re-activated.

Auto-reset

When the auto-reset function is enabled, the pump will be restarted automatically after 30 minutes in alarm condition. If, after restarting, the pump has not been primed within 5 minutes of operation, the dry-running alarm will reappear. The auto-reset function will attempt to restart the pump every 30 minutes during the first 24 hours. Then there will be 24 hours between the restarting attempts.

9. Frost protection

If the unit is subjected to frost in periods of inactivity, the unit and the piping system should be drained before the unit is taken out of operation.

Note

The unit has no draining options, but mounting the unit in one of the positions shown in fig. 7 makes draining easier.

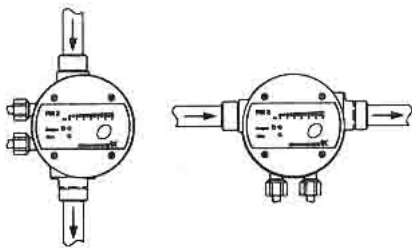

TM04 5459 3209

Fig. 7 Mounting positions making draining easier

10. List of alarms

Indication	Alarm	Cause
"Alarm" is permanently on.	Dry running.	The pump has been running without water.
"Alarm" flashes once per period.	Cycling.	The pump is cycling. Note: Occurs only if the anti-cycling function has been enabled. See section 8.2 <i>Anti-cycling</i> .
"Alarm" flashes twice per period.	Maximum operating time.	The pump has been running continuously for 30 minutes. Note: Occurs only if the function "maximum continuous operating time (30 minutes)" has been enabled. See section 8.3 <i>Maximum continuous operating time (30 minutes)</i> .
"Alarm" flashes three times per period.	Protection mode.	The pump has had too many start/stop sequences within a short period. Each pump start is delayed a few seconds to protect the installation. The start delay is active until normal operation has been re-established. Note: The protection mode will protect the installation when the PM 2 is set to start/stop with 1 bar differential pressure, i.e. when DIP switch 5 is set to "ON". The protection mode functions independently of the anti-cycling function.
"Alarm" flashes more than three times per period.	Internal fault.	Internal fault in the unit.

11. Technical data

Data	230 V model	115 V model
Supply voltage	1 x 220-240 VAC	1 x 110-120 VAC
Maximum inductive contact load		10 A
Frequency		50/60 Hz
Maximum ambient temperature		See nameplate.
Liquid temperature		0 °C - see nameplate.
p_{start} ¹⁾		1.5 to 5 bar
p_{stop} ²⁾		$p_{start} + 1$ bar
$Q_{min.}$		1.0 litre/min.
Time delay during stopping		10 seconds
Maximum operating pressure		PN 10 / 10 bar / 1 MPa
Enclosure class		IP65
Volume of internal pressure tank		0.1 litre
Dimensions		See fig. C, page 212

1) The start pressure (p_{start}) can be set in steps of 0.5 bar. The setting is described in section 5.1 *DIP switches*.

2) The stop pressure (p_{stop}) is only used in systems with a pressure tank. See section 7.2 *Start/stop with 1 bar differential pressure*.

The technical data may be limited by the pump data. See installation and operating instructions for the pump.

12. Fault finding chart



Warning

Before starting work on the pump/PM unit, make sure that the power supply has been switched off and that it cannot be accidentally switched on.

Fault	Cause	Remedy
1. The green light field for "0 bar" is off even if the power supply has been switched on.	a) The fuses in the electric installation have blown.	Replace the fuses. If the new fuses also blow, check the electric installation.
	b) The earth leakage circuit breaker or the voltage-operated circuit breaker has been tripped out.	Cut in the circuit breaker.
	c) No power supply.	Contact the power supply authorities.
	d) The PM unit is defective.	Repair or replace the PM unit.*
2. The green "Pump on" indicator light is on, but the pump does not start.	a) The power supply to the pump is disconnected after the PM unit.	Check the plug and cable connections, and check if the built-in circuit breaker of the pump is switched off.
	b) The motor protection of the pump has tripped out due to overload.	Check if the motor/pump is blocked.
	c) The pump is defective.	Repair or replace the pump.
	d) The PM unit is defective.	Repair or replace the PM unit.*
3. The pump does not start when water is consumed. "Pump on" is off.	a) Too big difference in height between the PM unit and the tapping point.	Adjust the installation, or increase the start pressure. See section 5.1 <i>DIP switches</i> .
	b) The PM unit is defective.	Repair or replace the PM unit.*
4. System without pressure tank: Frequent starts/stops.	a) DIP switch 5 set to "ON".	Set DIP switch 5 to "OFF". See section 5.1 <i>DIP switches</i> .
	b) Leakage in the pipework.	Check and repair the pipework.
	c) The non-return valve is stuck in open position.	Clean or replace the non-return valve.*
5. System with pressure tank: Frequent starts/stops.	a) The pressure tank has no precharge pressure, or the tank size is insufficient.	Check the tank precharge pressure, and recharge the tank, if necessary. If the size of the pressure tank is insufficient, set DIP switch 5 to "OFF", or replace the pressure tank.
	b) Leaky non-return valve.	Clean or replace the non-return valve.*
6. The pump does not stop.	a) The pump cannot deliver the necessary discharge pressure.	Replace the pump.
	b) The start pressure is set too high.	Decrease the start pressure.
	c) The PM unit is defective.	Repair or replace the PM unit.*
	d) The non-return valve is stuck in open position.	Clean or replace the non-return valve.*
7. The red "Alarm" indicator light is permanently on.	a) Dry running. The pump needs water.	Check the pipework.
	b) The power supply to the pump is disconnected after the PM unit.	Check the plug and cable connections, and check if the built-in circuit breaker of the pump is switched off.
	c) The motor protection of the pump has tripped out due to overload.	Check if the motor/pump is blocked.
	d) The pump is defective.	Repair or replace the pump.
	e) The PM unit is defective.	Repair or replace the PM unit.*

Fault	Cause	Remedy
8. System without pressure tank: The red "Alarm" indicator light flashes once per period.	a) Cycling. A tap has not been closed entirely after use.	Check that all taps have been closed. See section 8.2 <i>Anti-cycling</i> .
	b) Cycling. There is a minor leakage in the system.	Check the system for leakages. See section 8.2 <i>Anti-cycling</i> .
9. System with pressure tank: The red "Alarm" indicator light flashes once per period.	a) Cycling. The pressure tank has no precharge pressure, or the tank size is insufficient.	Check the tank precharge pressure, and recharge the tank, if necessary. If the size of the pressure tank is insufficient, set DIP switch 5 to "OFF", or replace the pressure tank. See section 8.2 <i>Anti-cycling</i> .
10. The red "Alarm" indicator light flashes twice per period.	a) Maximum continuous operating time (30 minutes). The pump has been running continuously for 30 minutes.	Check the system for leakages. Disable the function to allow the pump to run for 30 minutes. See section 8.3 <i>Maximum continuous operating time (30 minutes)</i> .
11. The red "Alarm" indicator light flashes three times per period, and each pump start is delayed a few seconds.	a) Too many start/stop sequences within a short period. The pressure tank has no precharge pressure, or the tank size is insufficient.	Check the tank precharge pressure, and recharge the tank, if necessary. If the size of the pressure tank is insufficient, set DIP switch 5 to "OFF", or replace the pressure tank.
	b) Too many start/stop sequences within a short period. The PM 2 is set to start/stop with 1 bar differential pressure, i.e. DIP switch 5 is set to "ON", but no pressure tank has been installed in the system.	Set DIP switch 5 to "OFF".
12. The red "Alarm" indicator light flashes four times per period.	a) Pressure sensor fault.	Repair or replace the PM unit.*

* See service instructions on www.grundfos.com > International website > WebCAPS > Service.

13. Further product information

Further information and technical details for the Grundfos PM 2 can be found on www.grundfos.com > International website > WebCAPS.

If you have any questions, feel free to contact the nearest Grundfos company or service workshop.

14. Disposal

This product or parts of it must be disposed of in an environmentally sound way:

1. Use the public or private waste collection services.
2. If this is not possible, contact the nearest Grundfos company or service workshop.

General Installation

Site Location

During off loading and positioning of the booster set care must be taken only to lift via the pump.

The unit location should be undercover, dry and freely ventilated. Protection from frost must be ensured.

Provision should be made for the disposal of system drained water.

Reasonable access to all parts of the set and adequate service work space must be provided. Provision for lifting equipment is recommended for units incorporating large pumps.

The floor base should be firm and level in all directions, and points are provided for floor fixing if desired. Isolation of the set if required should be by optional ant vibration stand together with pipework flexibles.

All system pipework should be aligned and self supporting preventing any strain or distortion within the unit.

Water Supply

The stored water should be clean and free from any foreign materials. There should be nothing suspended or dissolved to block or wear the pump internal components.

Electrical

The set is equipped with a 2.5m long connecting cable to be fitted with a suitable plug or wired into a fused isolator. A suitable fused supply should be used. All equipment should be earthed. This is a single phase 240V / 50 Hz unit.

All electrical works to be carried out by qualified personnel, complying with all current UK regulations.

Operation

The Fluid Controller (F.C.) is designed to start the pump when the system pressure falls, upon start up the unit continues to pump until the demand stops at which point the pump is stopped. Should there be a lack of water the internal float switch will disable the pump, if this happens check the water tank has refilled and press and hold the red button until the system has re-pressurised.

The F.C. has three indicator lamps:

Green:	Mains power on, pump ready to run
Yellow:	Pump Run
Red:	Fault

Start – Up

Ensure water is flowing into the water tank.

Open suction isolation valve.

Vent the pump via the hexagon head vent screw mounted on top of the pump until water is released, tighten nut.

Open discharge valve ¼ turn

Turn on power and allow pump to start.

Open discharge valve to half open and provide water to system. When fully up to pressure fully open discharge valve.

Maintenance

The fluid controller is maintenance free.

The pump should be checked for leaks or bearing noise.

Please contact Flow Mech Products for any repairs / service requirements.
