



English

Installation, Operation and Maintenance Instructions

Sun-Sub

Solar Water Pumping Systems

Contents

Declaration	4
United States Listing	4
FCC Declaration of Conformity	4
CE Declaration of Conformity	5
Warranty	6
Warranty Statement	6
Introduction	7
Intended Use	7
System Overview	7
Warnings	7
Solar Motor Controller (SMC)	8
Brushless DC Submersible Motor	9
Subrotor Pump Wet End	9
Optional Bore Level Probe	9
Specifications	10
Motor Specifications	10
Solar Motor Controller Specifications	11
Cable Specifications	13
Pump Specifications	14
Installation	15
Block Diagram	15
Installation Procedure	16
Commissioning	20
Electrical Connections	20
Starting the system	20
Operation	22
Operation of the SMC	22
Float Switch input	23
Pump Speed Control	23
Sun-Sub Totaliser Operation	23
Pressure Cut off system.	24
Solar Display Unit	25
Trouble Shooting Guide	26
Maintenance	27
Solar Motor Controller (SMC)	27
Motor	27
Subrotor Pump Wet End	27
Spare Parts	31

Declaration

United States Listing

United States test laboratory (NRTL) listing is provided by United States Test Company (USTC)



Listing Number: E1231003

The standard that the system meets is:

UL 61010

The product was first listed by USTC in:

2007

The products covered by this Listing:

- SUN SMC3000
- SUN SMC700W
- SUN SMC350
- SUN ELECT TRACK
- SUN DISP UNIT.

FCC Declaration of Conformity

This equipment has been tested and found to comply with the limits for a Class A digital device, pursuant to part 15 of the FCC Rules. These limits are designed to provide reasonable protection against harmful interference when the equipment is operated in a commercial environment. This equipment generates, uses and can radiate radio frequency energy and if not installed and used in accordance with the instruction manual, may cause harmful interference to radio communications. Operation of this equipment in a residential area is likely to cause harmful interference in which case the user will be required to correct the interference at his own expense.

Declaration

CE Declaration of Conformity

The Manufacturer of the products covered by this Declaration is:

Mono Pumps (Australia) Pty Ltd
338-348 Lower Dandenong Road
Mordialloc, Victoria, 3195, Australia

The directives covered by this Declaration:

89/336/EEC	Electromagnetic Compatibility directive, as amended.
73/23/EEC	Low Voltage Equipment directive, amended by 93/68/EEC.
98/37/EC	Machinery directive.

The products covered by this Declaration:

SUN SMC3000, SUN SMC700W, SUN SMC350, SUN ELECT TRACK.

The basis on which conformity is being declared:

The products identified above comply with the protection requirements of the EMC directive, with the principal elements of the safety objectives of the Low Voltage Equipment directive, and with the essential health and safety requirement of the Machinery directive. The manufacturer has applied the following standards:

IEC61010, EN 55011

The technical documentation required to demonstrated that the products meet the requirements of the Low Voltage Equipment directive has complied and is available for inspection by the relevant enforcement authorities.

The CE mark was first applied in:

2007

Signed: S. Watt

Authority: Engineering Manager
Mono Pumps (Australia) Pty Ltd

Date: August 30th, 2007

Attention!

The attention of the specifier, purchaser, installer, or user is drawn to requirements and limitations to use that must be observed when these products are taken into service to maintain compliance with the above directives. Details of requirements and limitations to use are contained in the product manual.

Warranty

Warranty Statement

1. The Sun-Sub Solar Water Pumping System manufactured by Mono Pumps are covered by warranty for a period not exceeding twenty-four months from purchase.
2. Mono Pumps will make good by repair, or at their option, the replacement of faulty parts under warranty, providing always that:
 - (a) The equipment was correctly installed and properly used in accordance with Mono Installations and Operating instruction and accepted codes of good engineering practice.
 - (b) The claim for goods under warranty arises solely from faulty design, material or workmanship.
 - (c) The repair is carried out in the Mono Pumps factory or by an authorised agent or distributor appointed by Mono Pumps.
 - (d) All freight costs to and from the factory or repair agent are to be paid by the purchaser.
3. In the case of equipment or components which are not of Mono Pumps manufacture, but supplied by them, the warranty is limited to that extended by the suppliers or manufacturers of such equipment.
4. Mono Pumps warranty does not cover any of the following:
 - (a) Claims for third party liability of damage caused by failure of any of the company's products.
 - (b) Damage caused by abnormal operating conditions, war, violence, storm cataclysm or any other force.
 - (c) Damage caused by the equipment being used for an application for which it is not recommended.
 - (d) Damage caused by sand or abrasive materials, corrosion due to salt water or electrolytic action.
 - (e) Damage to the SMC if the SMC has been opened by removal of the back plate before being returned to Mono.
 - (f) Damage to the motor if the motor is found to have been disassembled before being returned to Mono Pumps.
 - (g) Damage caused by running the pump dry.
5. The decision of Mono Pumps in relation to any claims or disputes over warranty is final.
6. The warranty is in lieu of all other warranties and conditions expressed or implied, written or oral, statutory or otherwise, which are hereby negated and excluded.
7. This express warranty does not exclude any conditions or warranty implied by the Trade Practices Act 1974 or separate State laws and in addition to any other right, that the original purchasers or any subsequent purchaser may have at law.

In case of claim please contact your Authorised Mono Pumps dealer or contact Mono Pumps (Australia) Pty Ltd.

Introduction

Intended Use

The Sun-Sub Solar Water Pumping system is designed for pumping potable water from boreholes using solar power. Do not use the system for any other purpose.

The protection provided by the equipment may be impaired, if the equipment is used in any other manner than designed.

System Overview

Mono Pumps Sun-Sub Solar Water Pumping Systems are comprised of four main parts:

- 1 Either a stationary or tracking solar array.
- 2 Solar Motor Controller (SMC).
- 3 Brushless DC Submersible Motor with electrical drop cable.
- 4 Subrotor Pump (Wet End) which is direct coupled to the submersible motor.

Additional items such as Bore Caps, Termination Kits, Water Level Controllers (WLC's), Float Switches, etc. may also be supplied with the system. The pump rising main, discharge piping, bore cap and all equipment foundations and ancillary structures, unless otherwise requested is the responsibility of the installer. The installation, operation and maintenance of the Solar Array are not covered in this manual. Please refer to the Solar Arrays manual for information on this part of the solar water pumping system.

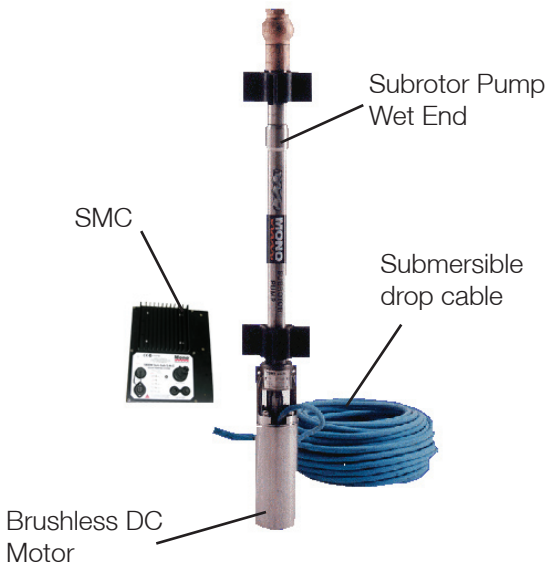

Warnings



Solar arrays can deliver voltage levels up to 160V DC. Always unplug the SMC from the array before working on any electrical wiring on the SMC or Motor Cables. In the event that alterations are required to the array itself, it is essential to cover the front of the array with a blanket or other suitable material to completely stop electrical generation.



The output voltage from the SMC to the Motor is 180V DC. Always unplug the SMC from the array before working on any electrical wiring on the SMC or Motor Cables.



All electrical connections in the solar water pumping system are made via plug and socket. The solar array must be fitted with a switched socket to accept the plug from the SMC and to ensure that the system can be completely isolated from the power source when required.



When installing or removing the pump from the borehole always use suitable lifting equipment to prevent injury.

Introduction

Solar Motor Controller (SMC)



Do not handle electrical connections when wet. Electric shock can occur.

The SMC comprises a solar maximum power point tracker and brushless DC motor control electronics combined in the one enclosure.



The MPPT converts and adjusts the voltage on the solar array to maximise power generation and increases or reduces this voltage to suit the demands of the motor controller.

The motor controller is an electronic commutator replacing the brushes in conventional DC motors. The motor controller senses back EMF voltages from the motor to determine the rotor position. This information is fed into a micro computer to calculate the energising sequence for the motor phases.

Features include:

- Input power ranges from 150 Watts to 1500 Watts from solar modules (refer to specifications for voltage, current and power limits for each SMC model.)
- Microprocessor controlled maximum power point

tracking continuously changes the array voltage and monitors the input power level thus following changes in the maximum power point of the array. This technology extracts the maximum available power from the solar modules.

- Remote On/Off control via float, pressure switch or water level control via probes placed in the bore hole.
- Electronic pressure cutoff system.
- Easily accessible On/Off switch.
- Interface to an optional Hand Held Display Unit
- Variable motor speed control via front panel or the optional Hand Held Display Unit.
- Thermal overload protection
- Input current overload protection detects if too many solar modules are connected to the SMC or if high currents are supplied from a battery source.
- Output current overload protection stops the system if the discharge pressure from the pump is too high.
- If the power output from the array is too low to start the pump, the system goes into “sleep” mode before attempting to restart the pump. This reduces load on the circuits and heating of DC motors.
- Low motor speed cut off to reduce pump and motor wear.
- Float Switch Input Protection prevents damage if accessory devices connected to the float switch socket are wired incorrectly.
- Status lights to tell the operator what the system is doing.

Introduction

Brushless DC Submersible Motor

The Mono Pumps Sun-Sub System uses a high efficiency, brushless, sensorless, permanent magnet, DC, submersible motor designed for coupling to the Mono Pumps Subrotor submersible pump. The pump and motor are suitable for use in 100mm (4") or larger standard boreholes.

The motor has a sealed, permanent magnet rotor and supported by rolling element bearings with all the drive electronics housed separately on the surface in the SMC. No sensor is required to determine rotor position within the motor.

Subrotor Pump Wet End

The progressing cavity pump has been designed specifically for use on the Sun-Sub system. The hard chrome plated rotor provides long life. The low interference design of the rotor and stator ensure low starting torque while maximising the pumping efficiency.

The high operating efficiency of the motor pump and SMC ensures that the maximum amount of water can be pumped over the whole day and during cloudy conditions.

Optional Bore Level Probe



Part # SUN S0346

Mono can supply a separate level probe for fitment into the bore or well. This probe device plugs into the Float Switch outlet on the SMC.

A bore level switch is recommended if the flow of the bore is lower than the maximum flow rate of the pump.

The bore level probe will protect the pump from dry running if the water level in the bore drops to the level of the inlet to the pump.



Dry running of the pump will damage the rubber stator in the pump. Damage resulting from dry running is not covered by the system warranty.

Specifications

Specifications

Motor Specifications

Size Range			
Output Power Rating	300W	600W	1200W
Nominal Torque Rating	0.7Nm	1.5Nm	3.0Nm
Nominal Speed at rated power	3000rpm	3000rpm	3000rpm
Variable Speed Control	Yes via SMC	Yes via SMC	Yes via SMC
Efficiency at Nominal Torque Rating	85 %	85 %	85 %
Electrical Characteristics			
Maximum Operating Voltage (motor)	180V	180V	180V
Input Voltage Range	0-180V DC	0-180V DC	0-180V DC
Operating Frequency Range	0 - 100 Hz	0 - 100 Hz	0 - 100 Hz
Maximum Current	3 amps	5 amps	8 amps
Mechanical Specifications			
Motor Casing Length	366 mm	411 mm	456 mm
Outside Diameter	93mm	93mm	93mm
Weight	8 kg	10kg	12 kg
Minimum Bore Diameter	100 mm (4")	100 mm (4")	100 mm (4")

Mounting arrangement

All motors built to NEMA standard 17/5/72 (except Shaft)

“Submersible Motors for Deep Well Pumps 4 inch”

Output shaft designed to suit direct connection to the Subrotor Pump Flexishaft.

Materials	All models
Casing, end caps, rotor can, external shaft	316 stainless steel
Studs, screws, nuts and washers	316 stainless steel
Cable plug	Santoprene/gold plated contacts/nylon
Rotor core	Mild Steel
Thrust bearing	7203 BECBP
Radial bearings	6202
Mechanical seal	Carbon / Ceramic
Magnets	NdFeBr (Neodymium Iron Boron)
Lubricant	Caltex White Oil Pharma. Complies with FDA regulation CFR 172.878 and CFR 178.3620(a)
Cable	4 core 1.5mm ² submersible
O rings	Nitrile

Water Quality

Maximum Water Temperature	34 deg C, also see Pump Specifications
pH range	8.5 to 6.0
Hardness Range	2000 Mg/L
Salt Concentration	500 ppm

Specifications

Solar Motor Controller Specifications

Electrical

Solar Array Input

300W / 350W SMC

Voltage : 30 to 100 VDC
Current : 0 to 5 A
Solar Array: 350W Max.

600W / 700W SMC

Voltage : 30 to 165 VDC
Current : 0 to 5 A
Solar Array: 700W Max.

Series 3000 SMC

Voltage : 30 to 165 VDC
Current : 0 to 15 A
Power: 1500W Max.
Solar Array: 3000W Max.

Motor output

300W / 350W SMC

Voltage : 0 to 180V
3 Phase switched DC
Frequency: 0 to 100 Hz
Current : 0 to 3 A

600W / 700W SMC

Voltage : 0 to 180V
3 Phase switched DC
Frequency: 0 to 100 Hz
Current : 0 to 4 A

Series 3000 SMC

Voltage : 0 to 180V
3 Phase switched DC
Frequency: 0 to 100 Hz
Current : 0 to 9 A

Float Switch connector

Switch input (pin 3,4)

Operation Normally closed
Shutdown on open contact
Current: 3mA (closed circuit)

Voltage: 15V (open circuit)

Auxiliary Supply (pin 1,2)

Voltage: 15VDC Nominal
Current: 50mA max (10V)

Com Connector RS232
9600 baud
rts/cts

Environmental

Storage Temperature: -10 to 60C
Operating Temperature: -10 to 50C
IP Rating: Type 3, Water and dust tight.
Humidity: 95% Max.

Dimensions & Weight

Dimensions (Carton)
390 x 275 x 290mm
Weight (in carton) 6.5Kg
Refer following page for further
dimensions.

Lightning Protection

In a solar water pumping system it is necessary to avoid having two earth points. (e.g. The motor itself and the earth rod attached to the solar array frame.) Mono recommends tying the pump safety wire to earth and bonding across to the earth stake with a 1.0"-2.0" galvanized earth strap.

The most vulnerable point is at the motor cable entry to the electronics where it is possible to receive an extreme earth potential rise after a lightning strike nearby.

Metal Oxide Varistors are fitted on the array input and Transorbs on the Motor output.

Specifications

Series 3000 SMC Dimensions

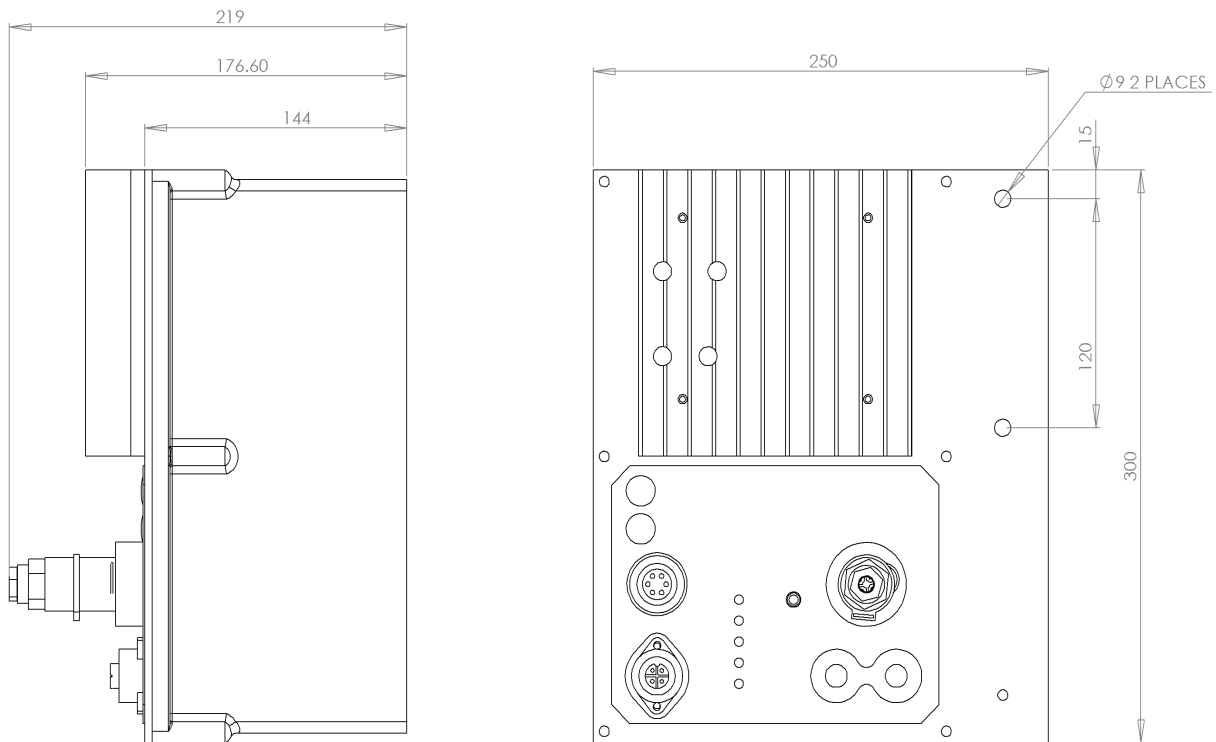

350 / 700W SMC Dimensions

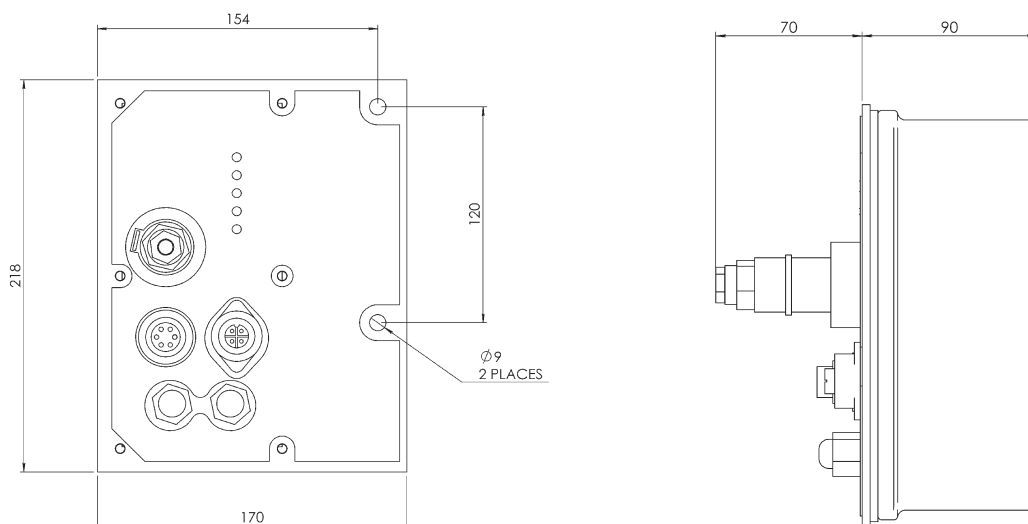

Specifications

Cable Specification

Motor

Motor Plug	180V, 9A	
Cable	Double Insulated	
	250V	
	4 Core	2.5mm ² for lengths <80m 4mm ² for lengths >80m

Array

Array Plug	165V, 15A	
Cable	Double Insulated	
	1000V	
	Single Core	4mm ²

Float Switch

Float Switch Plug	15V, 50mA	
Cable	Double Insulated	
	250V	
	4 Core 0.5mm ²	Systems with two float switches
	2 core 0.5mm ²	System with one float switch

Com Port

Com Port Plug	15V, 50mA	
Cable	Double Insulated	
	250V	
	6 Core	

Specifications

Pump Specifications

Size Range

Model Numbers	SM022	SM041	SM042	SM061	SM062	SM101	SM151
Maximum Speed [rpm]	3000	3000	3000	3000	3000	3000	3000
Flow at Maximum Speed [lpm]	20	40	40	60	60	100	150
Max Discharge Pressure [kPa]*	1500	750	1500	750	1500	750	750
Pump length without motor [mm]	860	850	940	850	940	890	900

(* Discharge pressures are maximum for the pump only. Pressure limitations due to motor current will result in lower maximum pressures for some system.)

Mechanical Specifications

Typical Weight without motor 7.9 kg

1½ inch BSP threaded outlet

Mounting arrangement

To NEMA standard 17/5/72 motors (except Shaft)

“Submersible Motors for Deep Well Pumps 4 inch”

The pump can be mounted on a NEMA shaft if an adaptor is used.

Materials	All models
Motor Adaptor	316 cast stainless steel
Pump Barrel	304 stainless steel
Socket Adaptor	304 stainless steel
Stator	304 stainless steel tube with natural rubber lining
Flexishaft	431 stainless steel coated with Halar
Rotor (Standard)	316 stainless steel coated with Hard Chrome Plating
Rotor MK 3	316 stainless steel
Rotor MK 5	316 stainless steel
Non Return Valve	Bronze with Nitrile seat and anti-rotating pin
O rings	Nitrile

Rotor Selection - Temperature

150W and 300W SYSTEMS		
Temperature	Model	
	SM022	SM041
up to 25°C	Mark 1 Rotor	Mark 3 Rotor
26°C - 34°C	Mark 3 Rotor	Mark 5 Rotor
34°C+	Contact Mono Pumps	Contact Mono Pumps

375W SYSTEMS +	
Temperature	For All Models
up to 28°C	Mark 1 Rotor
28°C - 34°C	Mark 3 Rotor
34°C+	Contact Mono Pumps

NOTE: performance may slightly reduce at temperatures below 15C"

Installation

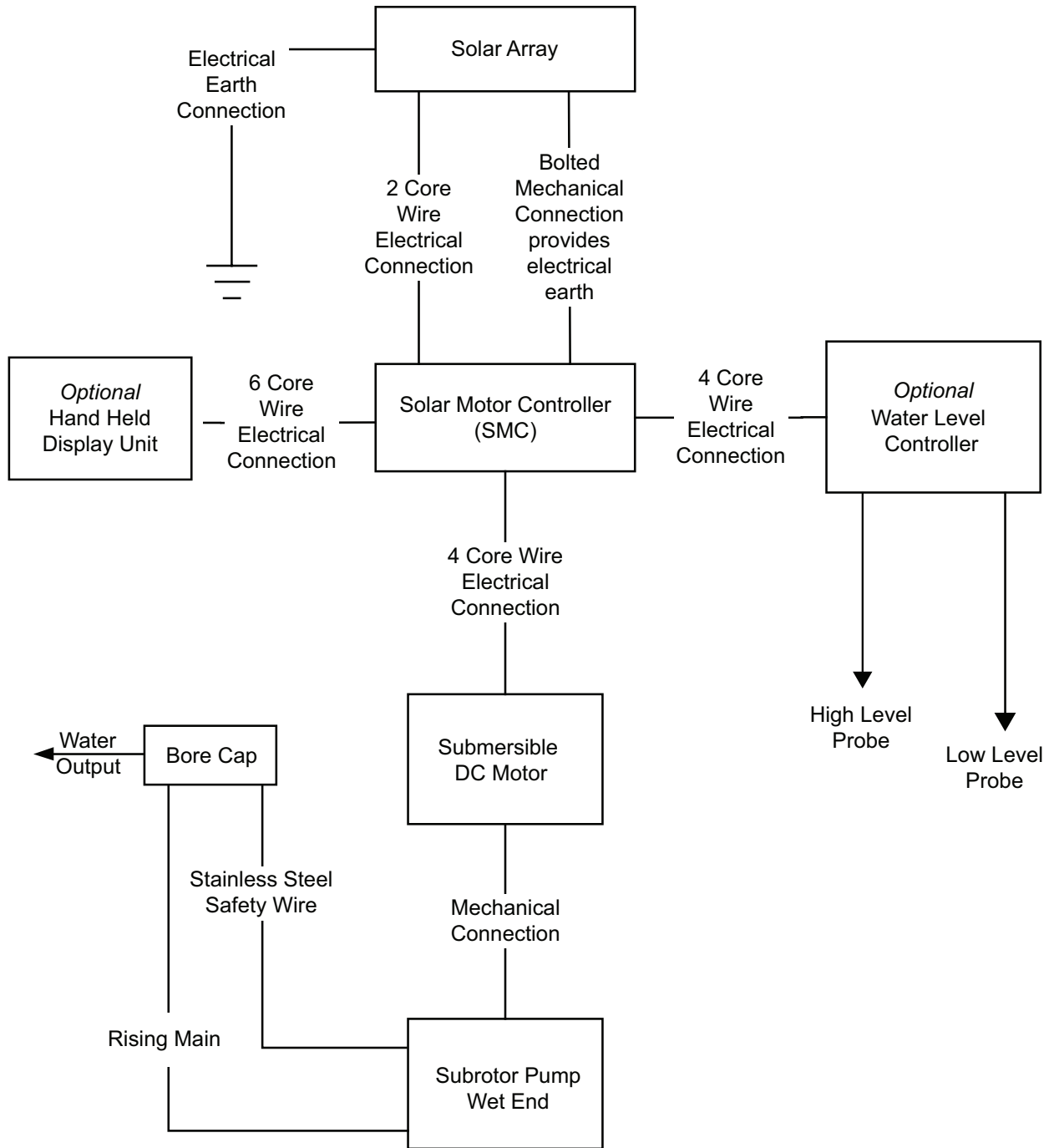

Installation

Installation Procedure

General

The following describes the installation of the Pump, Motor and SMC. Refer to the separate Solar Arrays manual for information on installing the Solar Array.

The Warranty does not cover damage due to running the pump dry. If there is a possibility that the pump will pump more water than the borehole can supply Mono Pumps recommend that a Water Level Controller is fitted to the system.

Note that the Warranty does not cover damage to the motor or pump caused by water quality outside the limits specified in the Specifications section of this manual.

Installing the Pump

Prepare the Bore Cap

Assemble the bore cap as shown below

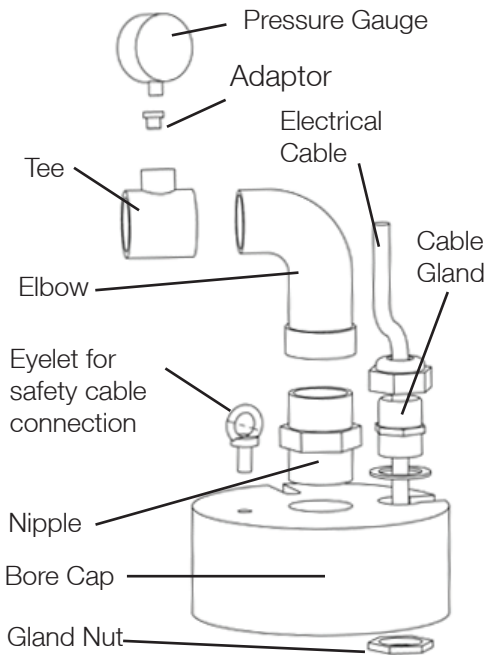

Determine the Pump Setting Depth

It is important to set the pump at the correct level in the borehole. Make sure that the unit is at least one metre above any gravel layer and one metre below the maximum drawdown level.

Prepare the Pump

If the bore hole is less than 6" in diameter it will be necessary to trim the rubber stabilisers on the pump as shown below.

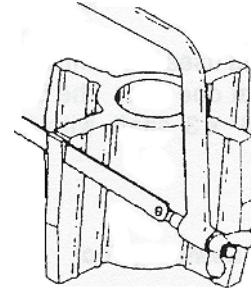

The pump can be installed on various rising main materials including polyethylene pipe. If using a polyethylene rising main Mono Pumps recommend that Class 12 pipe be used with cone type compression couplings. Screw the fitting that connects the pump to the rising main into the threaded outlet on the top of the pump.

Lay the rising main out along the ground. Cut the rising main to the correct length and connect to the pump and borecap. The motor cable should be taped to the rising main every 3 metres with electrical tape. Leave 100 mm of slack in the electrical cable between each taping to allow for stretch of the rising main.



If the stretch of the rising main is not allowed for, the electrical cable will be pulled tight when the pump is installed resulting in failure of the cable splice or cable gland on the motor.

Installation

If a Water Level Controller is being used the bottom probe should be taped to the raising main with the power cable. The bottom probe should be positioned above the pump as shown below. The top probe is best left untapped so that it can be raised and lowered in the bore as required.

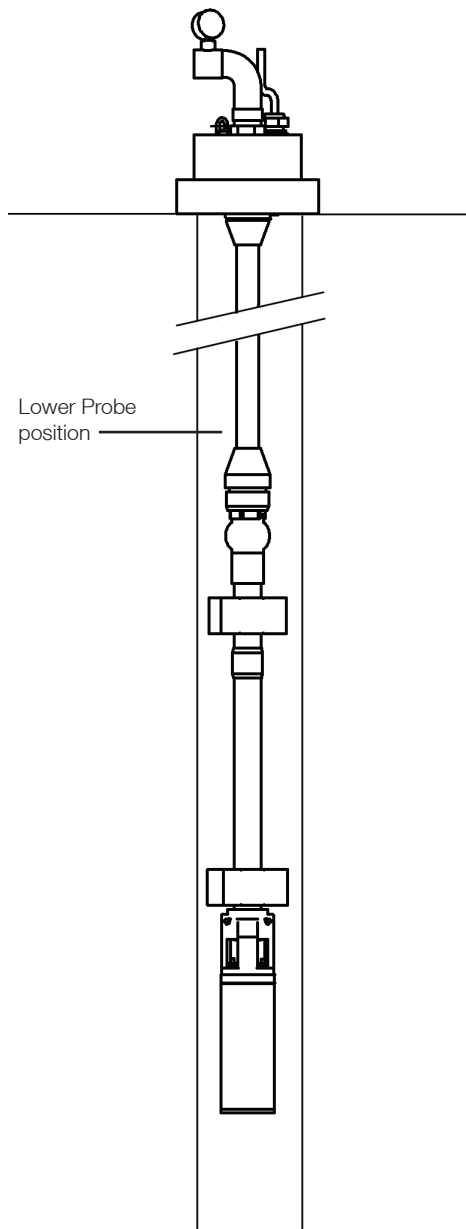

As an initial setting the top probe should be positioned about 1 metre above the bottom probe. It is not necessary to separate the probes by a large distance as it is with some AC pumping systems. (In AC systems the probe separation is used to control the number of pump starts per hour because more than 20 starts per hour can cause the motor to overheat). The Sun-sub system will not be damaged by repeated starts so large separations are not required.

The pump must be supported by means of a stainless steel safety cable. Assemble the clamps onto each end of the stainless steel safety cable.

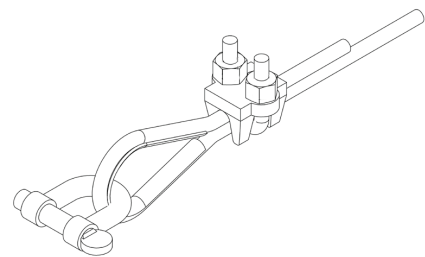

Connect the stainless steel safety cable to the pump as shown below. (Note the motor is not shown for clarity.)

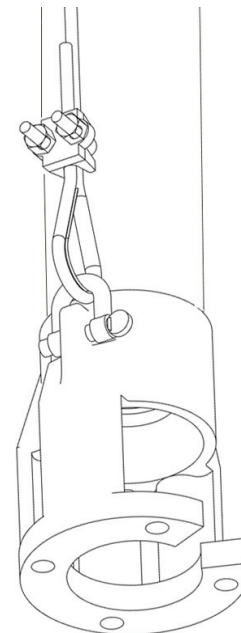

Installation

The other end of the safety cable will be connected to the bore cap when the pump has been installed.

Before installing the pump the rotor and rubber stator of the pump needs to be lubricated with a little water. Disconnect the pump from the motor by removing the four nuts and pulling the main body of the pump away from the motor. The rotor and drive shaft will remain attached to the motor. Wet the rotor and stator in with clean water.



Do not use any lubricants on the rubber stator as these may interfere with or damage the stator's rubber material.

Reassemble the pump body to the motor and tighten the four nuts.

Installing the pump into the borehole



Warning: Do not lower or ever support the pump by the submersible electrical cable.

As the pump is lowered down the bore, the weight should be taken through the safety cable or rising main.

When the pump has reached its required depth the bore cap should be positioned on the top of the bore. Slacken the safety cable slightly so that it can be ensured that the pump is hanging vertically. The safety cable can be secured to the bore cap at the completion of the installation.

The electrical cable should be passed through a cable gland where it passes through the borecap to prevent chafing of the insulation. The electrical cable should be buried underground in electrical conduit between the borecap and the array frame to protect it from damage.

Motor Plug



The output voltage from the SMC to the Motor is 180V DC. Always unplug the SMC from the array before working on any electrical wiring on the SMC or Motor Cables.

SMC End

If the motor plug was removed from the cable during the installation process it is important that the wires are reconnected correctly to ensure that the pump runs in the correct direction.

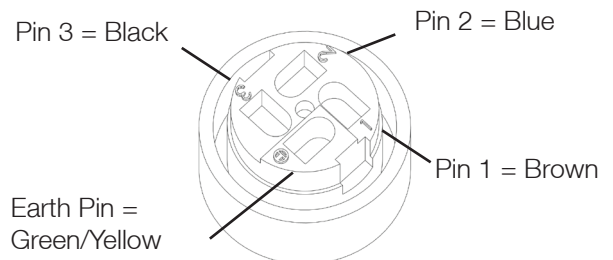
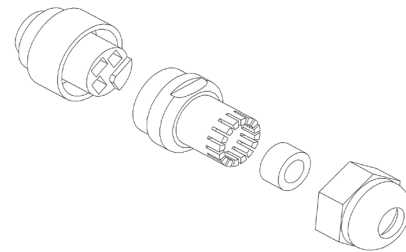

Motor End

If the motor plug was removed from the motor, it must be replaced with a new O Ring's and sealant grease. For disconnection or connection of the plug, the pump barrel must be removed.

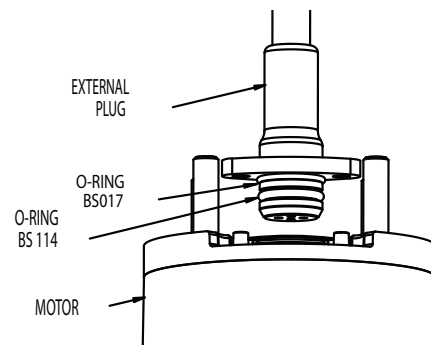

Installation

Non-Return Valve on the Delivery Pipe

If the system is fitted to a pressure tank or the static head above the bore cap is greater than 20 metres then it is recommended that a non-return valve be installed as close as possible to the outlet at the bore head, even though the pump is already fitted with one. The use of a non-return valve will ensure that the pump does not turbine backwards if the non-return valve on the pump were to leak.

Mounting the Solar Motor Controller (SMC)

Attach the SMC to the bracket on the array frame using stainless steel M8 bolts, nuts and washers.

Earthing the Solar Array

The post or one of the support legs of the solar array must be earthed to provide lightening protection for the system and to prevent the array structure from becoming "live" in the case of a fault with the array or SMC. If the array frame is more than a few metres from the bore hole the earth point of the array must be connected to the pump safety cable. This is to prevent large voltage differences occurring between the motor and the SMC if lightening strikes the ground near the solar system.

Refer to the Commissioning section on the following page for instructions on connecting the electrical wiring and starting the system for the first time.

Wiring the Float Switch Plug



Warning: Ensure that all plugs are fitted correctly to the SMC. Failure to fit the plugs correctly will allow water to enter into the SMC leading to failure. This is not covered by warranty.

The Float Switch is fitted with a blanking plug as standard. The assembly of the float switch plug and wiring of the blanking plug are shown below.

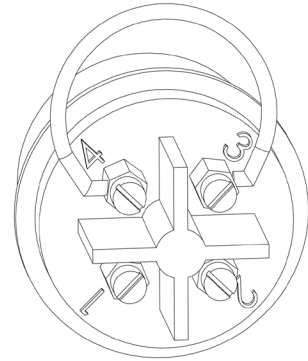
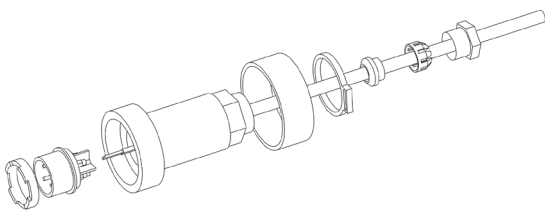

The SMC will only operate when pins 3 and 4 of the float switch are connected. The blanking plug contains a link wire to connect these two pins. External switches can be wired into the float switch to remotely start and stop the pump.

Float Switch Pin Connections

Pins 1 is the positive output of 15 volt DC power supply used to power the optional water level controller.

Pin 2 is the negative output of the 15 volt DC power supply

Pin 3 is the positive connection to the float switch.

Pin 4 is the negative connection to the float switch.

Note: The 15 Volt power supply is not suitable for charging lead acid batteries.

Commissioning

(Starting the system for the first time)



Warning: Incorrectly connecting the positive and negative wires between array and the SMC will result in damage to the electronics inside the SMC.

Electrical Connections

The Solar Motor controllers utilise 2 “MC” style leads to connect the SMC to the Solar array.

Switch the SMC off using the On/Off Switch on the front of the SMC.

Plug the Motor Plug into the motor socket on the SMC. Ensure that the motor cable is adequately protected from damage by animals or livestock. The cable should be attached to the array post or support frame with electrical ties to prevent the motor plug from being accidentally pulled out of the SMC.



Solar arrays can deliver voltage levels up to 160V DC. Always unplug the SMC from the array before working on any electrical wiring on the SMC or Motor Cables. In the event that alterations are required to the array itself, it is essential to cover the front of the array with a blanket or other suitable material to completely stop electrical generation.



Warning: Removing the motor plug from the SMC or shorting the wires together when the SMC is operation, could result in damage to the electronics in the SMC.



Warning: Ensure that all plugs are fitted correctly to the SMC. Failure to fit the plugs correctly will allow water to enter into the SMC leading to failure. This is not covered by warranty.



Switch the isolation switch on the array to the off position (if fitted).

Connect the 2 metre MC cables between the SMC and solar array switch located on the back of the solar array.

Fit the blank float switch plug into the float switch socket on the front of the SMC. The SMC will not operate without either the blank plug or a correctly wired accessory plug fitted to the SMC. For the initial system test, it is recommended to use the jumper plug. Other accessories such as the Water Level probe can be installed if necessary after the operation of the SMC and motor is confirmed.

Starting the system

When starting the system for the first time it is recommended that the discharge pipe is not connected to the outlet at the bore cap. This will allow the water to flow freely where the quality of the water can be observed.

Turn the array isolation switch to the on position (if fitted).

The Solar Power Status Light should light up indicating that power is available from the array.

Switch the SMC On using the On/Off switch on the SMC. The Motor Start Status Light should flash indicating that the pump is starting. When the pump has started the Motor Start Status Light will turn off and the Max Speed / Motor Run Status Light will flash or turn on continuously.

Listen to the operation of the pump. If air can be heard bubbling up in the bore the pump may be running backwards. Immediately turn off the SMC and check the SMC motor plug wiring before restarting the system. If the pump is run backwards for more than 20 seconds the stator may be damaged.

It may take a few minutes for the bore water to reach the surface depending on the depth of the pump setting. If the water that flows from the bore cap is cloudy or contains sand it is important the pump is not turned off until the water flows clear. Turning off the pump before the water clears could result in sand being left in the pump preventing the pump

Commissioning

from restarting. If this occurs it will be necessary to pull up the pump and clean the rotor and stator.

Turn off the SMC and connect any discharge pipe work. Connect any accessory systems such as the WLC, float switches, pressure switches etc.

Turn on the SMC and re-check the operation of the system.

If during the initial operation the pump lowers the well water level until suction is discontinued (i.e. the pump is running dry) then turn off the system immediately. If possible the pump should be lowered further into the bore hole or fit a Tank and bore level controller to prevent the pump from running dry and damaging the rubber stator. Allow the bore to “recover” for about 30 minutes before restarting the pump. The maximum speed of the pump can be reduced using the optional Mono Solar Display Unit as a means of preventing dry running. (Refer to the Pump speed control instruction in the operation section of this manual). If this method is used it will be necessary to carefully monitor the bore for a number of days to ensure that the pump does not run dry at any time. Damage to the pump caused by dry running is not covered by the warranty.

Operation

Operation of the SMC

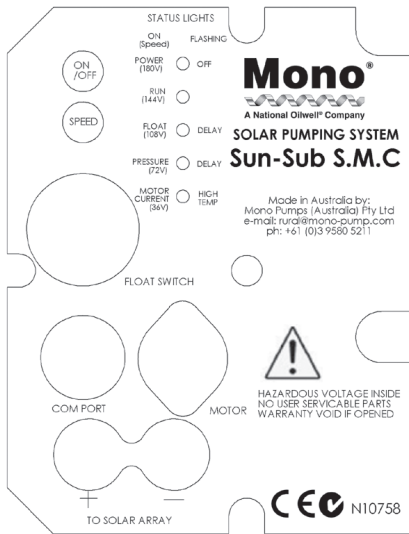

Max Speed / Motor Run

Lights up fully when the motor is running at maximum speed

Flashes proportional to the speed of the motor at lower speeds

Float Indicator

The indicator lights up when the float switch input is open

It flashes when the SMC is in the float switch delay mode

Pressure

The pressure indicator lights up when the pump pressure exceeds the preset limit

The indicator flashes when the SMC is in the pressure delay mode

Overload / Input/Temp

Lights up if the motor is overloaded

Flashes slow if the input current reaches the maximum value

Flashes fast if the SMC over heats

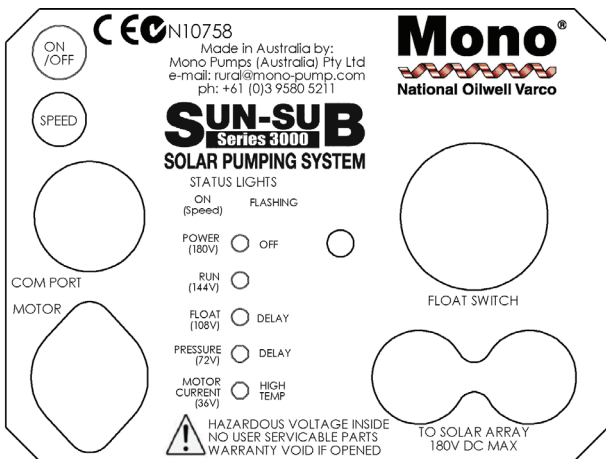

Status Lights

The SMC features five multifunction system status lights (LED's). The first function of each light is indicated by continuous illumination of the LED. A flashing LED indicates the second function. The functions of the LED's are as follows:

SMC's Diagnostic Indicators

Solar Power / Low Power

Lights up when solar power is available.

The indicator flashes when the unit is turned off via the On/ Off switch or via the Com Port.

The indicator turns off if insufficient power is available to the SMC.

Operation

Float Switch input

The SMC's Float switch input has been designed to operate on single bore probe (SUN S0346) or tank float switch. The SMC will attempt to start the motor if there is a closed electrical connection across the float switch input (Pins 3,4). If the circuit is opened via the bore/float switch the motor will be stopped and the Float Indicator will illuminate. Once the bore/float switch has re-closed, a 15 minute time delay will become active, continuing to stop the motor. The Float indicator will flash as the timer is counting down. When 15 minutes has elapsed the SMC will attempt to start the Motor and the indicator will turn off.

Pushing the On/Off button will cancel the time delay on the float switch input.

The float switch input can be configured to run the optional Mono tank and bore level controller (SUN 0415).

Pump Speed Control

The pump speed feature can be used to limit the maximum speed of pump, therefore reducing the peak flow of the pump. This is useful when the peak flow needs to be reduced as in a low yielding bore.

These SMC's have 2 methods of reducing the maximum motor speed, firstly by pushing the front panel speed switch or by using the Solar Display unit.

a/ Front Panel Speed Button

Pushing the Speed button will increase the maximum speed by 20% each push. The initial push will illuminate the number of indicators corresponding to the current maximum speed setting, if the switch is pushed again the maximum speed will be increased by 20% (36V). Once the absolute maximum setting of 100% (180V) has been attained the next push will revert back to the 20% setting.

b/ Solar Display Unit (SDU)

To reduce the maximum pump speed using the SDU, plug the SDU into the SMC and follow these steps:

- i/ Press enter (#) on the SDU to clear any previous operation.
- ii/ Press * 6 # , the display should read "Max Motor Volt ?"
- iii/ Enter the desired maximum motor voltage between 36 and 180V, for 100V press 100# , the display should now read "Max MotorV=100V".

Note: The SDU setting will override the maximum available Speed button setting, therefore the front panel switch can only increment the speed up to the SDU setting.

Sun-Sub Totaliser Operation

The Sun-Sub controllers have an inbuilt totaliser function. This function counts every revolution the pump has done since installation. This reading can be used as a method for totalising the flow from the installation.

- 1/ To recall number of Pump Revolutions from the SMC enter *8# on the Solar display unit for 150, 300, 600, 1200W SMCs (software V1.3 or greater) enter *7# on the Solar display unit.
- 2/ Pump conversion factors

SM022	150
SM041/42	75
SM061/62	50
SM101	30
SM151	20
- 3/ To calculate litres pumped
Total Litres = Revolutions/Pump Factor
e.g. 1340000 Revs SM042 Pump
 $1340000/75 = 17,867$ litres

Operation

Pressure Cut off system.

This system has been designed for use as a method for controlling the filling of a remote storage tank. A float valve is fitted in the remote tank, once the tank is full the valve closes, this causes the pressure to build up in the system tripping the Pressure cutoff system. The pressure cutoff system electronically monitors the Pumps operating pressure, if the pump pressure rises above the preset limit the pump will automatically stop for 30 minutes, after 30 minutes has elapsed the SMC will then attempt to restart the pump. The pressure indicator on the front panel shows whether the system has been shut down via the pressure cutoff system. The indicator will illuminate when the pressure limit has been reached, it will flash when the unit is counting down for 30 minutes.

SETUP (The Mono Pumps Solar Display Unit "SDU" is required for this operation)

- 1/ Program the Pump model (Normally programmed before the unit is shipped from Mono).

If you want to check which pump model is selected, press * 7 # on the SDU keypad, the SDU will now ask for a Pump Model. Press 0 # ,the SDU will now display the current pump selection.

To change the Pump model ,using the SDU press * 7 #, the SDU will now ask for a Pump Model. Enter the 3 number pump code corresponding to the Pump model fitted to the motor then push the # key.

Example. SM022=022#, SM061=061# ect.

- 2/ Measure Pump Pressure.

Start the pump, when the pump is running at its maximum speed and the pipes and tanks are full, measure the pressure using the SDU. Using the SDU press * 5 # ,this will give a dynamic pressure reading. Once you have determined the maximum operating pressure add a minimum of 20 metres (to allow for any variances) to the value, this will give you the Pressure cut off point.

Example. SDU maximum reading 55M
Pressure Cutoff Point = 75M

Note: A pressure gauge fitted to the pump outlet will be helpful in determining the maximum pressure of the system, but importantly the SDU pressure displayed is measured at the Pump not the top of the bore. Allowance must be made for this when programming the cutoff point.

- 3/ Set Pressure Cutoff Point

Using the SDU press * 2 #, the SDU will now ask for a pump pressure. Enter the require pressure limit then press the # key. e.g. 65 Metres=65# , 35 Metres=35# ect.

If you want to check what the trip pressure is set to, press * 2 #, the SDU will now ask for a pump pressure. Press 0 # the SDU will now display the current pressure trip setting.

- 4/ Test the system.

Close the float valve fitted in the tank to simulate a full tank. This should make the pressure in the system increase over the trip point, the pressure indicator should turn on and the pump shutdown. The pressure Indicator will flash to indicate the system is in delay mode. If a SDU is connected to the SMC it will display the time to restart in Minutes.

Pushing the On/Off button will cancel the time delay once the pressure cutoff system in active.

Operation

Solar Display Unit

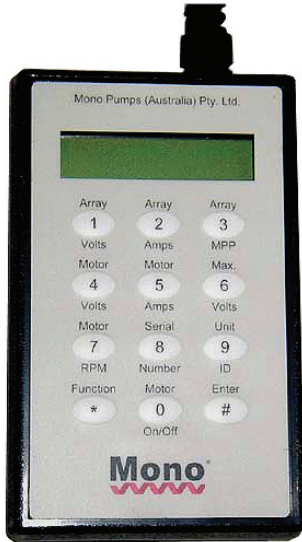

The Solar Display Unit is an optional accessory that allows the operator to extract data from the SMC and change software settings within the SMC. The unit has a two line display. The first line displays information on the current operating mode of the SMC. E.g. Motor Starting, Input current overload, maximum motor speed etc. The second line of the display shows information depending on the currently selected function. The primary functions are listed on the keypad on the front of the unit. E.g. To see the array voltage press key 1 then the Enter key. The second line will now display the array voltage. The voltage will be updated continuously until a new function is selected.

The display unit is powered from the SMC but also contains a 9 volt battery. If the SMC is running the display unit takes power from the SMC (i.e. it will operate even if the internal battery is flat.) If the SMC is not connected to an array or the array is not generating any power, the display unit will run of the internal battery. The display unit will also power up the microprocessor on the Power Master so that settings can be changed in the SMC without the SMC being connected to a solar system. When the SMC is running of the Solar Display Unit the Solar Power / Low Power light on the SMC will flash indicating that there is insufficient power to operate the pump.

A list of the primary functions is shown below.

Primary Functions

- 0 Motor On/Off (turns the system on or off)
- 1 Array Volts
- 2 Array Amps
- 3 Array Maximum Power Point (Normally auto but if the voltage has been fixed the set voltage will be displayed.)
- 4 Motor Volts
- 5 Motor Amps
- 6 Max Motor Volts (The default is 180 volts but by setting a lower maximum motor voltage the maximum speed of the pump can be controlled. This is useful in applications where the yield of the bore is low.)
- 7 Motor RPM
- 8 Serial Number and Date of Manufacture of the SMC
- 9 Unit ID of the Solar Display Unit

Second Functions

There are additional functions that can be accessed by pressing the * key followed by the number key and enter then the value and enter. E.g. To set a new maximum motor voltage of 90 volts press * 6 enter 9 0 enter.

- 1 Array Power
- 2 Set Pressure Limit (0 reads current setting)
- 3 Set Array MPP (Used to turn off the maximum power point tracking and set the voltage to a fixed value. 0 returns to auto mode.)
- 4 Motor Power
- 5 Pump Pressure
- 6 Set Maximum Motor Voltage
- 7 Set Pump Model (0 reads current setting)
- 8 Revolution Counter
- 9 Restores the SMC to the factory default settings

Operation

Trouble Shooting Guide

Status Light	State	Possible Problem	Solution
Solar Power	Off	Loose array connection	Test array & rectify problem
		Faulty array	Test array & rectify problem
		Faulty SMC	Return to Mono for assessment
		Not enough solar power	Check array position or wait for more sun light
	Flashing	On/Off switch set to off	Push On/Off switch
Remote control set to off		Push On/Off switch	
Motor Speed	On but no flow from pump	Motor disconnected from pump	Reconnect motor to pump / check direction of rotation
		Broken Flexishaft /Coupling	Replace Flexishaft / Coupling
	Flashing / slow	Array partially faulty	Test array & rectify problem
		Pump load increased	Check for obstruction in the pump non-return valve or increased head due to pipe blockage
	Off	System is waiting for enough power	Need more solar power
		Stuck pump	Clear or prime pump
Faulty motor		Return to Mono for assessment	
Off/Float	On	Pins 3,4 of float switch connector open circuit	Check link in dummy plug
		Float / pressure switch open circuit	Check operation of float / pressure switch
	Flashing	In delay mode	Push On/Off switch twice
Pressure	On	Pump Overpressured	Release Pressure in system
	Flashing	In delay mode	Push On/Off switch twice
Overload	On	Motor overload	Check system head
		Pump over pressured	Remove source of flow obstruction
	Flashing	Wrong array configuration	Test array & rectify problem
	Flashing/fast	SMC too hot	Check SMC location for ventilation

Maintenance

Solar Motor Controller (SMC)

There are no user serviceable parts inside the SMC. If the SMC is not functioning correctly it must be returned to Mono Pumps for service.



Any disassembly of the SMC by unauthorized personnel will invalidate all warranty. The back plate/heat sink must not be removed under any circumstances.

Motor

There are no user serviceable parts inside the Motor. If the Motor is not functioning correctly it must be returned to Mono Pumps for service.



The Warranty on the motor is void if it is disassembled. All repairs and maintenance must be carried out at the Mono Pumps factory.

Subrotor Pump Wet End

Disassembly

Remove the four nuts and spring washers connecting the pump to the motor.

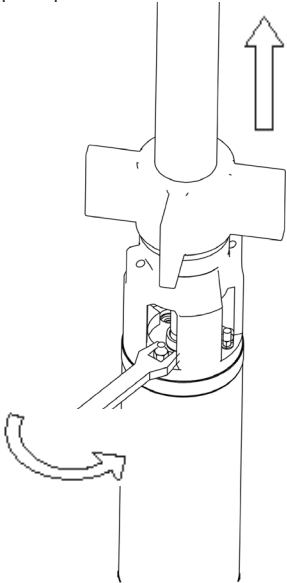

Pull the pump off the rotating assembly being careful to pull in a straight line to prevent damage to the flexishaft coating.

To remove the stator grip the Non-Return Valve in a vice or pipe wrench and unscrew the Stator by gripping the Socket in a second wrench.

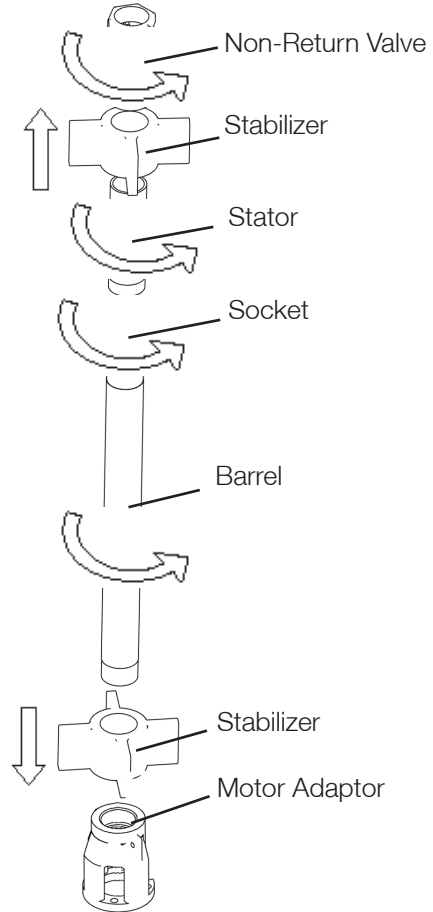

WARNING: When removing the Stator it is very important that the tube is not distorted by pipe wrenches, vice jaws etc. Damage to the outside of the stator tube can result in loss of performance and seizure of the pump.

Maintenance

Inspect the stator for signs of damage to the rubber surface and replace if necessary. It is not generally necessary to disassemble the pump Barrel from the Motor Adaptor.

Inspect the Rotor for signs of wear and replace if damaged. If it is necessary to replace the rotor it is recommended that the stator be replaced at the same time.



WARNING: Do not damage the green Halar coating on the flexishaft. Attempting to remove the flexishaft by gripping it with a pipe wrench will destroy the coating and void the warranty. The Halar coating protects the flexishaft from corrosion. Damage to the coating can lead to fatigue failure of the flexishaft.

To remove the Rotor from the Flexishaft, unscrew the rotor by using a spanner on the flat on the rotor and a second spanner on the flats on the motor shaft. Do not grip the flexishaft. If the flexishaft unscrews from the flexishaft adaptor and remains in the rotor it will be necessary to carefully grip the exposed metal between the thread and the green Halar coating with multigrips or similar and unscrew the rotor using a spanner on the flats.

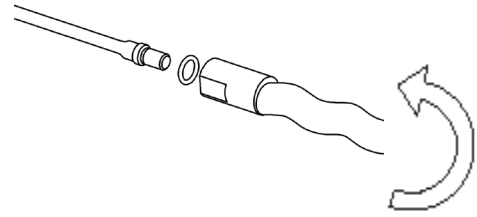
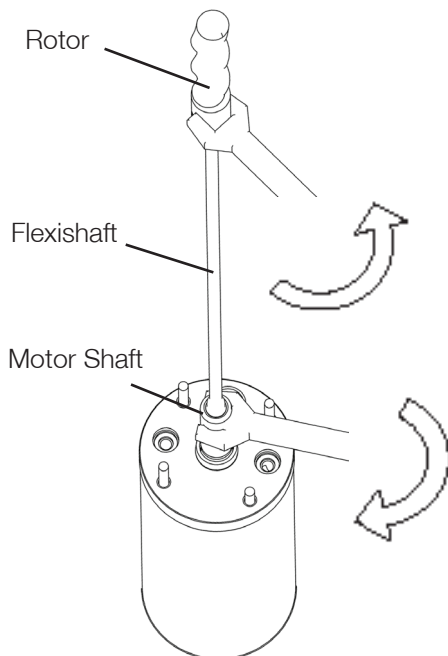

Assembly

Always replace the o-rings in the motor shaft and rotor with new parts. Coat the Flexishaft threads with nickel or copper based anti-seize. Screw the assembly together by hand and tighten using a spanner on the rotor head flat and a second spanner on the motor shaft.

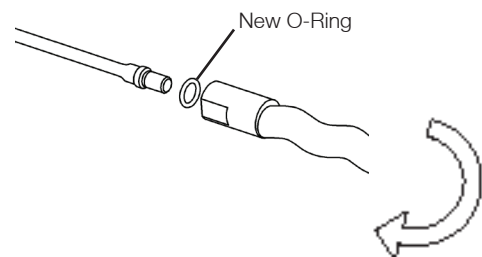
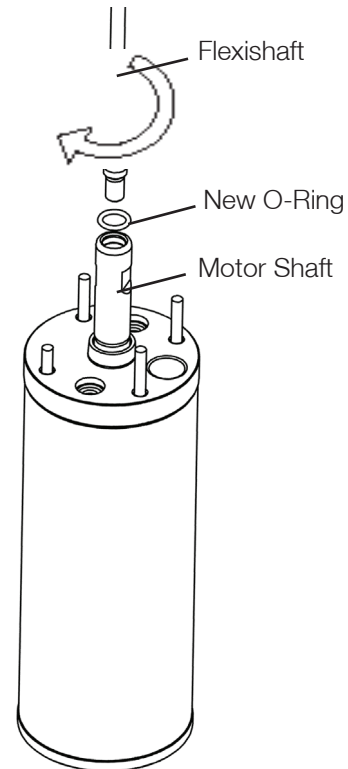

Maintenance

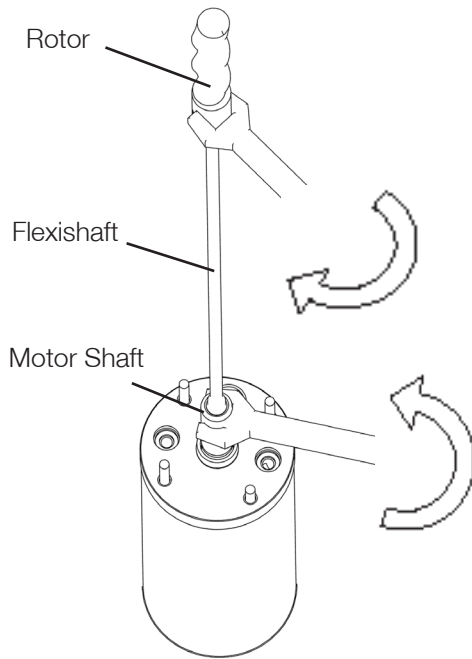

Body Parts

If the pump barrel has been removed from the motor adaptor piece reassemble these components first. Fit a stabiliser over the pump barrel. Lightly coat both pump barrel threads with Stag pipe sealant. If too much Stag is used the excess could be washed into the stator causing damage to the stator and seizure of the pump. Screw the pump barrel into the motor adaptor piece by hand. Screw the socket onto the pump barrel.

Check the orientation of the stator - one end is marked "Suction This End". Fit a stabiliser over the stator. Lightly coat both stator threads with Stag pipe sealant - be careful not to use excessive amounts. Screw the suction end of the stator into the socket by hand.

Screw the non-return valve onto the stator. (Make sure the check valve is on the correct way such that the flow through the pump will open the valve).

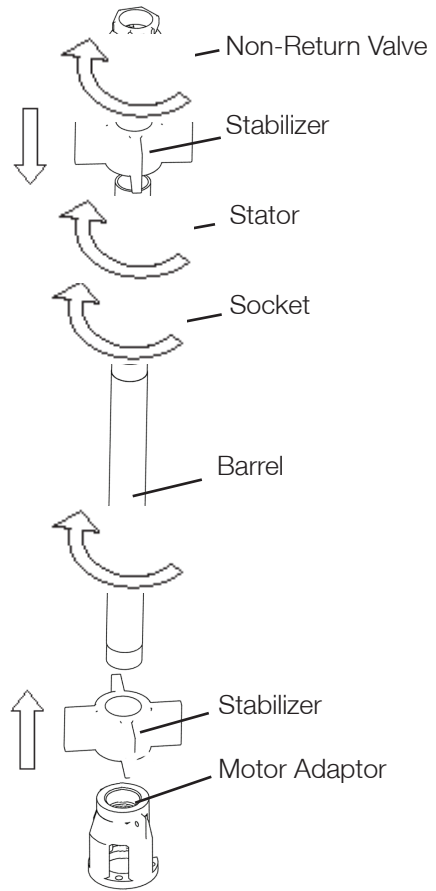

Tighten the assembly using a spanner or wipe wrench on the check valve and by passing a rod or large screwdriver through the motor adaptor piece. It is important that this assembly is tight to prevent it unscrewing in service. The Stag pipe sealant will act as a thread-locking agent when dry.



WARNING: Do not tighten the stator connections by using a pipe wrench, vice etc. on the stator tube. It is very important that the stator is not distorted by pipe wrenches, vice jaws etc. Damage to the outside of the stator tube can result in loss of performance and seizure of the pump.



WARNING: Do not use grease, soap, hand cream, etc. to lubricate the Stator. These products will damage the natural rubber stator and result in seizure of the pump. When assembling the rotor into the stator it is only necessary to wet the components in water.

Maintenance

Final Assembly

Wet the rotor and stator with water and slide the stator assembly over the rotor assembly. Some resistance will be felt as the rotor is pushed into the stator. Align the motor adaptor piece with the cable outlet on the motor and the motor studs. Push the stator assembly home. Fit the four spring washers over the studs. Fit the four M8 nuts and tighten with a spanner.

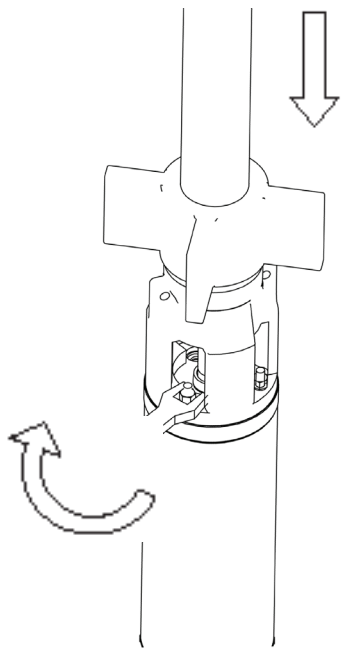

Spare Parts

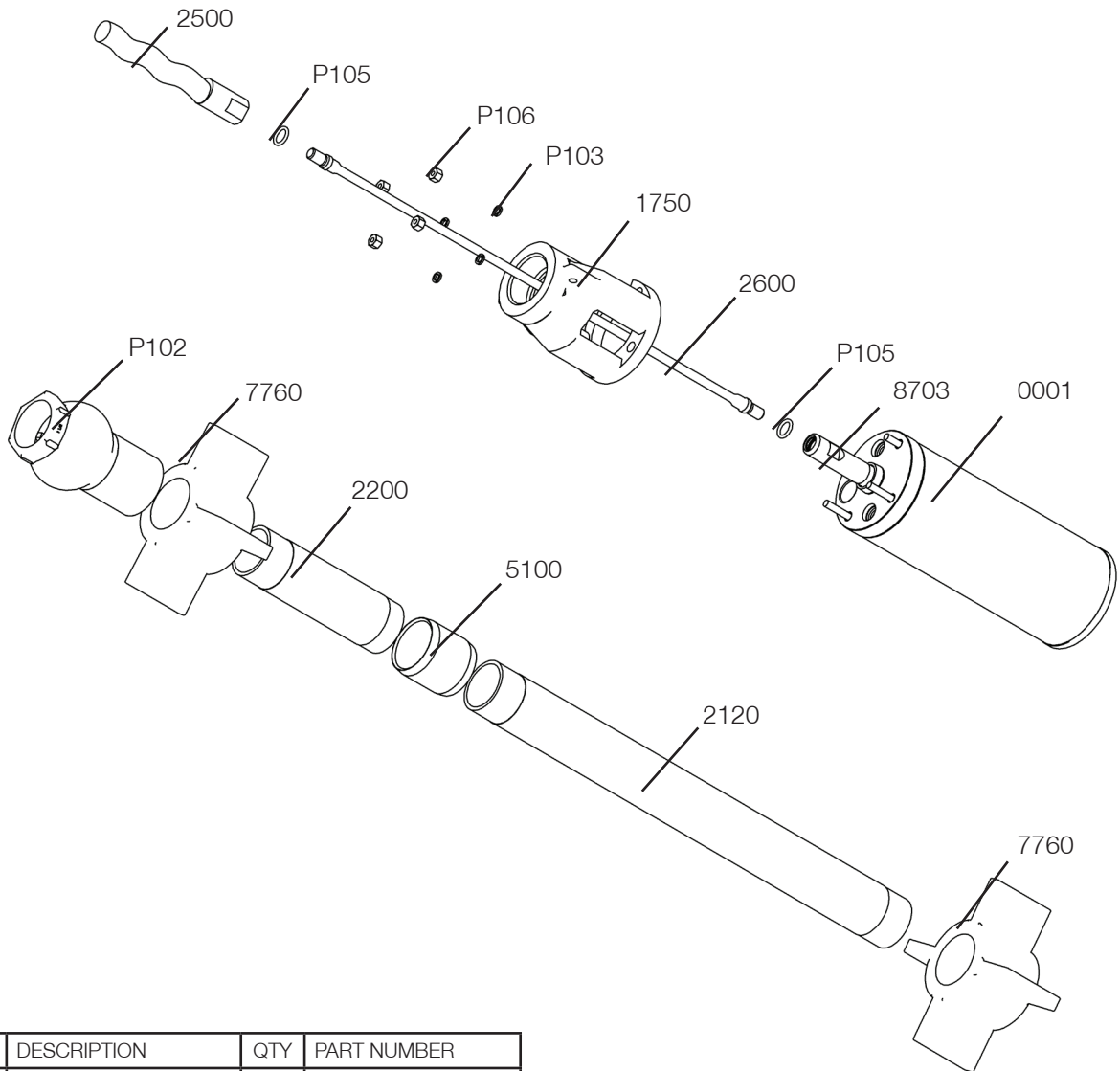

ITEM	DESCRIPTION	QTY	PART NUMBER
0001	300 W MOTOR	1	SUN MOT300W
	600 W MOTOR	1	SUN MOT600W
	1200 W MOTOR	1	SUN MOT1200W
1750	MOTOR ADAPTOR	1	ST SM041 1750
2120	PUMP BARREL	1	SS SM041 2120
2200	STATOR	1	SEE CHART BELOW
2500	ROTOR	1	SEE CHART BELOW
2600	FLEXISHAFT COATED	1	SM SM151 2650
5100	SOCKET	1	SF SM041 5130
7760	STABILIZER	2	RB STA 155X040
8703	THROWER	1	SWP 15100
P102	CHECK VALVE	1	VCV150
P103	SPRING WASHER	4	SUN 23185-3
P105	O RING	2	S211120P
P106	HEX NUT	4	SUN 23184-3

PUMP MODEL	ROTOR STATOR CHART	
	2500 - ROTOR	2200 - STATOR
SM021	SF SM021 2530	RA SM022 2210
SM022	SF SM022 2530	RA SM022 2210
SM041	SF SM041 2530	RA SM041 2210
SM042	SF SM042 2530	RA SM042 2210
SM061	SF SM061 2530	RA SM061 2210
SM062	SF SM062 2530	RA SM062 2210
SM101	SF SM101 2530	RA SM101 2210
SM102	SF SM102 2530	RA SM102 2210
SM151	SF SM151 2530	RA SM151 2210

Europe

Mono Pumps Ltd, Martin Street, Audenshaw
Manchester, M34 5JA, England
T. +44 161 339 9000
E. info@mono-pumps.com

D.M.I EST, 56, rue du Pont
88300 Rebeuville, France
T. +33 3 29 94 26 88
E. dmi-est@dmi-est.fr

Americas

Monoflo Inc., 10529 Fisher Road
Houston, Texas 77041, USA
T. +1 713 980 8400
E. inquire@monoflo.com

Monoflo S.A., Ing Huergo 2239
(1842) Monte Grande
Pcia. de Buenos Aires, Argentina
T. +54 11 4290 9940/50
E. info@monoflo.com.ar

Monoflo Canada, 6010 – 53rd Ave
Alberta, Lloydminster
T9V2T2, Canada
T: + 1 780 875 5584
E: info@monoflo.com.ar

Asia

Mono Pumps Ltd, No. 500 YaGang Road
Lujia Village, Malu, Jiading District
Shanghai 201801, P.R. China
T. +86 21 5915 7168
E. monoshanghai@nov.com

Australasia

Mono Pumps (Australia) Pty Ltd
338-348 Lower Dandenong Road
Mordialloc, Victoria 3195, Australia
T. 1800 333 138
E. ozsales@mono-pumps.com

Mono Pumps (New Zealand) Ltd
35-41 Fremlin Place, Avondale
Auckland, 1026, New Zealand
T. +64 9 829 0333
E. info@mono-pumps.co.nz

Melbourne	T.	03 8587 4303	F.	03 8587 4388
Sydney	T.	02 8536 0900	F.	02 9542 3649
Brisbane	T.	07 3350 4582	F.	07 3350 3750
Adelaide	T.	08 8447 8333	F.	08 8447 8373
Perth	T.	08 9479 0444	F.	08 9479 0400
Darwin	T.	08 8931 3300	F.	08 8931 3200
Kalgoorlie	T.	08 9022 4880	F.	08 9022 3660
Christchurch NZ	T.	+64 3 341 8379	F.	+64 3 341 8486

www.monopumps.com



© Mono Pumps Limited November 2009 Literature reference: MPA573-10

Mono® is a registered trademark of Mono Pumps Limited. seepex® is a registered trademark of seepex Seeberger GmbH + Co. NEMO®, NM® and NE® are registered trademarks of Erich Netzsch GmbH & Co Holding KG. NETZSCH® is a registered trademark of NETZSCH Mohnpumpen GmbH. Mono Pumps Limited is not an authorised distributor of parts and services for the products of Seeberger GmbH, Allweiler, NETZSCH Mohnpumpen GmbH, PCM, Robbins & Myers or Orbit and Mono Pumps Limited products are not associated with, endorsed by, or sponsored or manufactured by these companies.

NOV Mono®

One Company, Unlimited Solutions