



Water Treatment Solutions





About Us

Transvac Systems Limited is a privately owned Ejector Solutions provider formed in 1973.

As both a designer and a manufacturer of Ejectors, Transvac has full in-house control over process and mechanical design, supply of raw materials, manufacturing, scheduling and testing. With all of our procedures certified to BS EN ISO 9001:2008 the quality of the final product is assured.

Transvac is accredited to Module H of the Annexe III Pressure Equipment Directive (PED) and our products are CE marked where appropriate. We are also 1st Point Assessment (FPAL), UVDB and Achilles registered.

All products are custom designed to suit the process and mechanical requirements of each application to ensure maximum operating efficiency.

Transvac offers standard and exotic materials of construction including Hastelloy, Duplex, Super Duplex, Titanium etc.





Ejector Solutions for Water Treatment

Transvac Systems manufacture custom designed Ejector solutions for the process industries.

With over 40 years experience on the application of Ejectors, backed by a comprehensive list of references, Transvac's position as world leaders in Ejector technology is firmly established.

Our product range includes Ejectors for solid dosing (carbon, lime, salt etc), Venturi Aerators for effluent treatment, Jet Compressors for ozone/chlorine dosing, Jet Mixers for waste agitation and Jet Pumps for chemical dosing/dilution.

The TransPAC is a fully automated, containerised carbon dosing solution, providing once-through inline dosing to combat against taste & odour, pesticides and other contaminations with minimal need for building or groundwork.

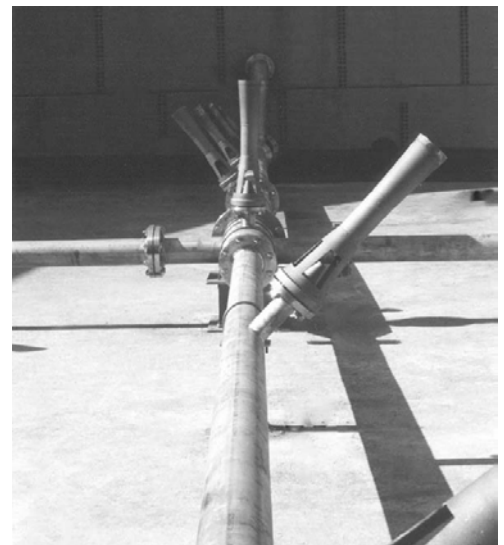

Recent Clients



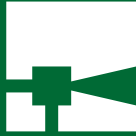

Tank Jet Mixers

Transvac Tank Jet Mixers are a mass momentum exchange device which uses the energy of pressurised liquid to entrain, mix and pump a secondary liquid. The principle is used for many process applications including blending, solids suspension, dilution and heat distribution.

In operation, pressurised motive liquid is discharged through the jet nozzle into the suction chamber. The change from pressure energy to kinetic energy (velocity) creates a region of low pressure that entrains liquid from within the process vessel via the open suction ports. The motive and suction liquid streams combine and mix under high shear conditions in the venturi diffuser. The resulting mixture is then discharged into the bulk of the process liquor as a high velocity turbulent jet.

Advantages:

- ▶ No moving parts
- ▶ No splashing or aerosol created
- ▶ Operates at variable depths
- ▶ No bridges or bearings used
- ▶ No in-tank maintenance needed
- ▶ Evenly distributes mixing
- ▶ Controllable mixing
- ▶ Simple, reliable and robust

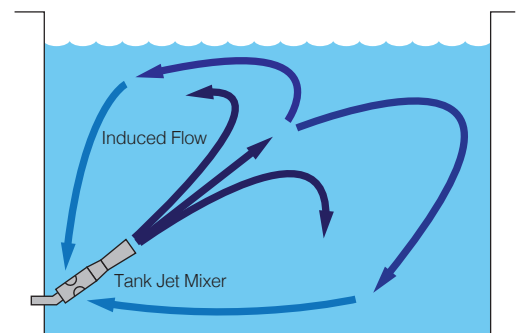

Standard Transvac Tank Jet Mixers entrain 3 parts suction liquid for every 1 part motive liquid with the discharge jet of 4 parts inducing further secondary mixing.

Each Tank Jet Mixer is designed to suit the process mixing requirement and single Mixers or a number of mixers mounted on an intank manifold are available. Transvac can offer the basic mixers or a complete system including pipework, pumps and valves.

Materials of construction are chosen to suit the process conditions, common materials include stainless steel, carbon steel, Polypropylene, PVCu, PTFE, and GRP. Hygienic designs are available for the food / pharmaceutical industry

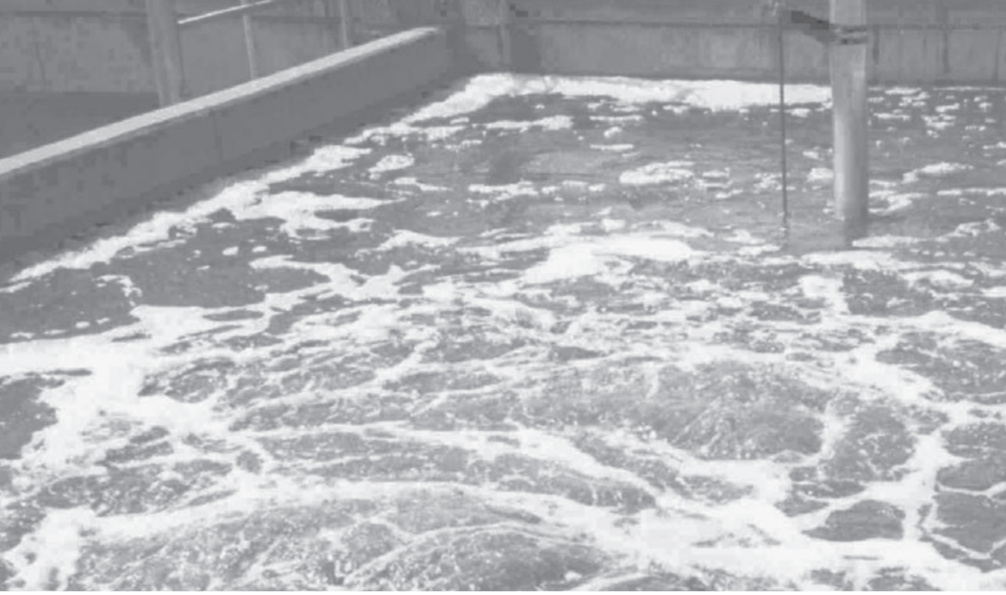

Venturi Aerators

Transvac Venturi Aerators are a mass momentum exchange device which uses the energy of pressurised liquid to entrain, mix and pump air into a secondary liquid.

Standard self aspirating units can operate at tank depths of up to 7 metres and offer typical efficiencies between 1.2 and 1.8 kgO₂/kWh at standard conditions. High alpha factors, simplicity, reliability and low cost make the Transvac Venturi Aerator a competitive with other forms of aeration equipment available on the market.

The action of the Venturi Mixer / Aerator is ideal for mixing balance tank effluent on industrial plants. The unit not only provides effective liquid / liquid mixing, but it also entrains atmospheric air to further enhance mixing and transfer oxygen into effluent.

The system works successfully with varying liquor depths and for keeping solids in suspension. A connection into the tank from the air stack also enables the unit to operate as a liquid / liquid mixer with no air entrainment.

With no parts within the tank requiring maintenance and with corrosion resistant materials of construction available, the Transvac Venturi Aerator is an ideal mixing device for plants handling aggressive hazardous effluent.

The oxygen transfer feature of the Transvac Aerator is used to it's full on food waste balance tank mixing because it can keep the effluent 'fresh', avoiding unpleasant odours.

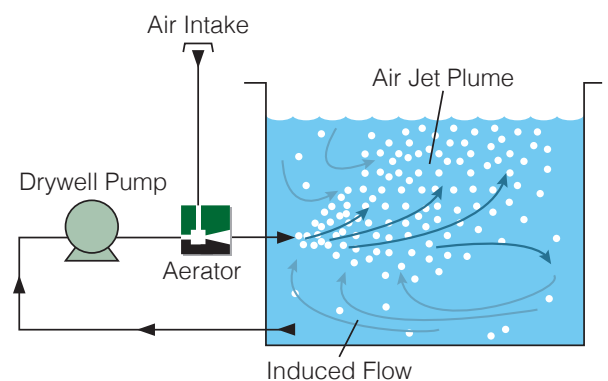

Advantages:

- ▶ No moving aerator parts
- ▶ High oxygen transfer
- ▶ High alpha factors
- ▶ Minimal maintenance
- ▶ Virtually silent operation
- ▶ No aerosol spray
- ▶ Simple to install and retrofit
- ▶ Materials to suit the process





Liquid Jet Pumps

Transvac has supplied thousands of units to the process and allied industries. Using liquid as the motive force Transvac Jet Pumps can accurately entrain, mix and dilute a secondary liquid, eliminating the need for mechanical dosing pumps and mixers.

In operation a high velocity jet of pressurised liquid discharged from the motive nozzle produces a region of low pressure in the suction chamber that entrains the secondary liquid. The two streams then thoroughly mix in the throat before the resulting mixture flows through the diverging cone to regain some pressure in order to overcome system discharge heads.

Typical Applications

- ▶ Chemical Dosing & Dilution
- ▶ Polyelectrolyte Production
- ▶ Ion Exchange Resins
- ▶ Activated Carbon / Lime
- ▶ Sludge & Slurry Handling

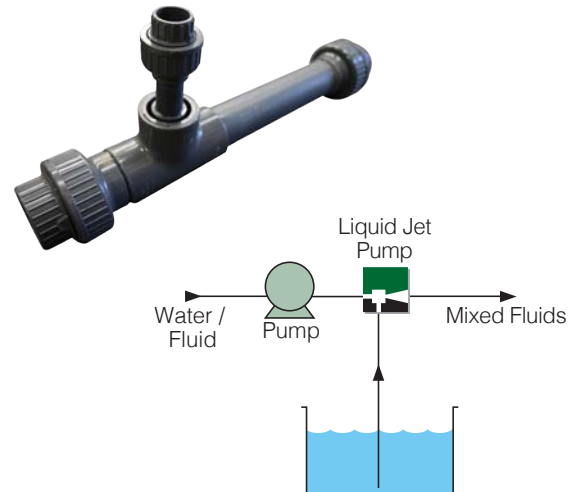

Liquid Jet Compressors

Transvac Liquid Jet Compressors have been extensively used for entraining ozone and atmospheric air in water treatment applications.

Using liquid as the motive force Transvac Jet Compressors can accurately entrain and mix air or gas in-line and discharge against a back pressure.

In operation a high velocity jet of pressurised liquid discharged from the motive nozzle produces a region of low pressure in the suction chamber that entrains the secondary gas. The two streams then thoroughly mix in the throat before the resulting mixture flows through the diverging cone to regain some pressure in order to overcome system discharge heads.

Advantages:

- ▶ Simple and reliable
- ▶ No moving parts
- ▶ In-line mixing
- ▶ Custom designed
- ▶ Materials to suit process
- ▶ No maintenance

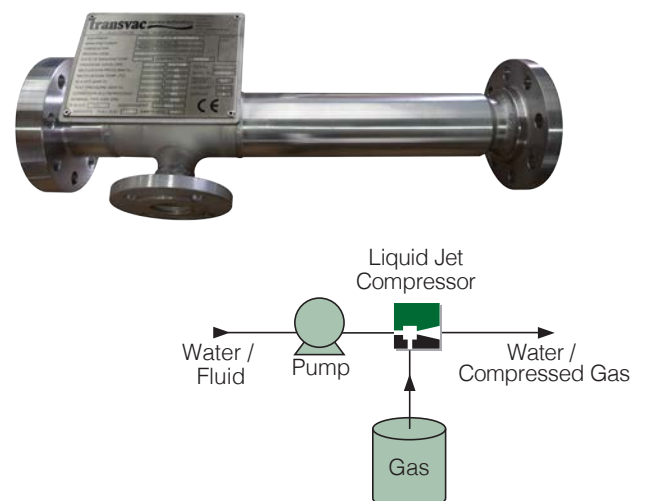

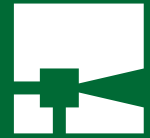

Liquid Jet Solids Pumps

A versatile method of entraining, mixing and pumping solids into liquids. The Venturi principle offers many advantages over other types of high shear mixing equipment on the market. Robust and highly reliable with no moving parts to wear, the units are virtually maintenance free.

Available in either stationary, portable or mobile models the custom designed Liquid Jet Solids Pump (LSP) units can be supplied as individual items or complete skid mounted systems including motive pump, valves etc. Powder can be loaded manually or automatically using screw feeders at ground level, thereby keeping powder handling at a minimum. In many cases fluid energy from existing pumps can be used which eliminates the need for additional power.

Depending upon the process conditions operation can be on a once-through or recirculation basis



Advantages:

- ▶ Reduced powder handling
- ▶ No moving parts
- ▶ Complete mixing of powders and liquids
- ▶ Materials to suit process
- ▶ Low level operation
- ▶ Reduced batch times
- ▶ No maintenance
- ▶ Existing pumps can often be used

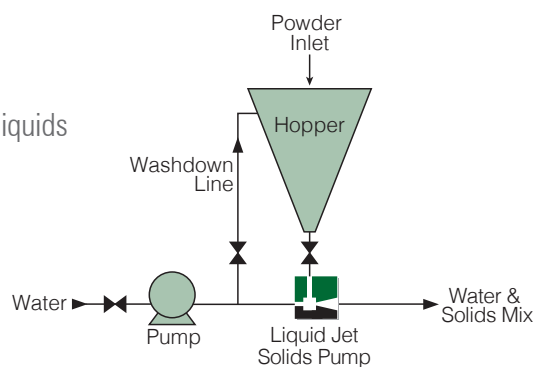

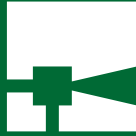

TransPAC - a complete PAC dosing solution



When water standards slip, you need to act fast. The fully contained, mobile TransPAC dosing solution puts you back in control.

With minimal need for building or groundworks, TransPAC provides a safe and secure home for your dosing solution. Simply hook it up and away you go.

TransPAC provides once-through inline dosing, so there are no batch mixing tanks to contend with and the fully programmable HMI control panel provides accurate and efficient dosing. After all, no one likes wastage.

The TransPAC is also supplied with a silo adapter kit which can be easily fitted by the site operator to enable the system to receive carbon from a site silo, rather than a bulk bag.

A Containerised **TransPAC** Dosing System Includes

Secure, vandal-proof container with lighting	✓
Transvac PAC Ejector, in-line wet mixing / pumping system	✓
Flexicon powder handling / metering system (bulk bag or silo fed option)	✓
Clean water, pressure booster pumps	✓
Water header tank	✓
Site specific control panel with alarm interface	✓
Interconnecting pipework and valves (manual or automated)	✓
Instrumentation	✓
Optional compressor	✓
Silo feed adapter kit	✓
Dust extraction system	✓

For more detailed information on TransPAC, see our TransPAC brochure or visit www.carbondosing.com



The silo feed adapter kit makes the system flexible to your site requirements and provides ultimate flexibility

Advantages of a **TransPAC** Dosing System

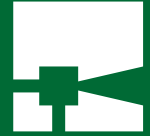

PAC dose rate to match works flow	✓
Accurate dosing, no PAC wastage	✓
Clean and reliable operation	✓
Once through in-line mixing	✓
Dosing lines flushed clean after use	✓
No wet mixing moving parts	✓
Minimal maintenance	✓
Simple to install and operate, minimal civil works required	✓
Hygienic design	✓
Manual or fully automatic operation	✓
Compatible with site telemetry	✓
Containers can be moved from site to site as required	✓
No requirement to involve M & E Contractors	✓

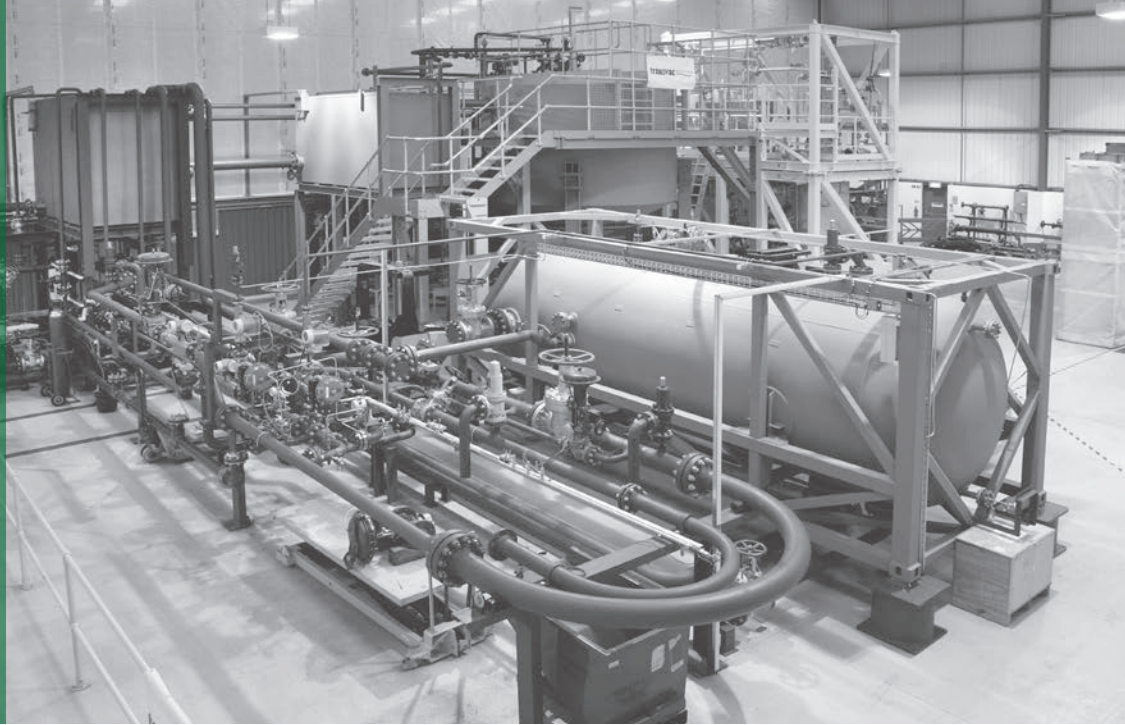

Research & Development Test Facility

Transvac officially opened its R&D Test facility in April 2010. The state-of-the-art test facility primarily develops new oil & gas Ejector technology for subsea processing, flare gas recovery, sand slurry pumping and production boosting.

Ejector applications for the nuclear, bio-fuel, chemical and wastewater industries are also under development.

The R&D test facility includes high and low pressure equipment for handling water, gas, multi-phase and

slurry. Test programmes are supported by CFD studies and include fundamental University research.

The Transvac facilities include liquid flow lines for high, medium & low pressure testing (in excess of 250 bar (g)) and solids handling systems.

Transvac performs functional validation tests for Ejectors used in the oil & gas, nuclear and process industries.

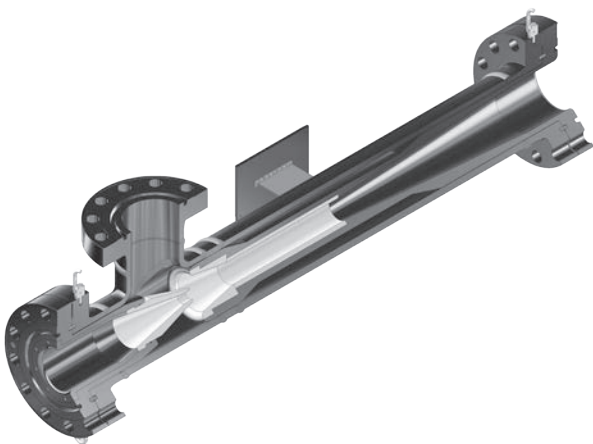

Why not visit Transvac head office and take a tour of the first-class R&D facility for yourself?



Research & Development - Key Research Areas

Fluid Structure Interaction

- ▶ Jet break up characterisation
- ▶ Coalescing and dispersion of multiphase flows
- ▶ Measurement techniques [laser Doppler]
- ▶ CFD model calibration [new code development]

High Motive Pressure Liquid Jet Compressor

- ▶ Optimisation & characterisation
- ▶ Scaled trials
- ▶ CFD model calibration

Low energy inline micro bubble generation

- ▶ Optimisation of new equipment and envelope testing

Gas Motivate Liquid Units

- ▶ Optimisation and stabilisation studies

Liquid Jet Pump Erosion Prediction Techniques

- ▶ Micro scale experimental trials
- ▶ CFD modelling and calibration
- ▶ Full scale Ejector testing
- ▶ Accelerated testing methods

Recent R&D clients:

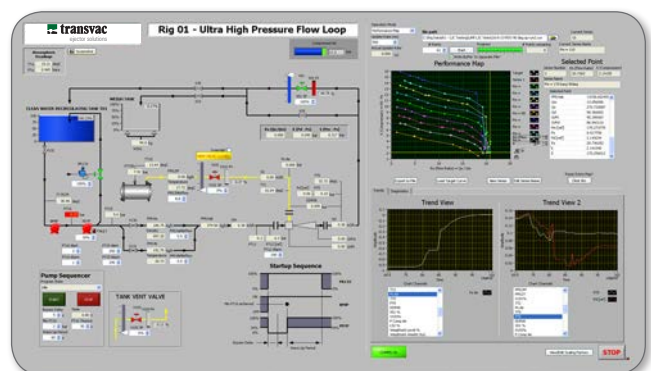



Transvac Systems Ltd., Monsal House, 1 Bramble Way, Alfreton, Derbyshire, DE55 4RH, UK
Tel: +44 (0) 1773 831100 | **Email:** sales@transvac.co.uk | **Web:** www.transvac.co.uk

Registered in England No. 1526398

www.carbondosing.com

