

EUROCLAD

Liner cladding profiles





CONTENTS



Introduction		3
Typical construction detail		3
19/1000mm	Liner	4
20/1066mm	Liner	4
MW5L	Liner	4
20/914mm	Liner	5
32/1000mm	Liner	5
Product reference	Instant reference	6
	Colour and finish	6
	Fire classification	6
	Thermal performance	6
	Roof lights	6
	Spacers	6
	Liner sealed at Manufacturers Recommendations	7
	Cover widths	7
	Fillers	7
	Curving	7
	Fixings	7
	Fragility	7
Corus Colorcoat® products and services		8



INTRODUCTION

Euroclad is one of the UK's leading manufacturers of steel and aluminium roof and wall cladding, with a wealth of manufacturing experience. Core products, including Elite Systems with their specified performance, low pitch roof systems and LINEAR façades are popular with clients, architects and contractors.

Founded in 1981 Euroclad has taken huge strides over more than 25 years, consistently investing in people and technology to satisfy customer needs and maintain its position at the forefront of the metal roofing and cladding industry.

As part of its commitment to quality, service and the environment, Euroclad operates a Quality Management System approved to BS EN ISO 9001:2000 and an Environmental Management System approved to BS EN ISO 14001:2004.

LINER PROFILES

One of the most significant developments in steel clad buildings in the '80's, was the inclusion of a steel liner. Cost effectiveness, simplicity and ease of installation all ensure that it has been one of Euroclad's consistently popular products for over 20 years.

This publication looks at the details of Euroclad liner sheets, each of which have been designed to match the cover widths of the external profiled sheets and can be purchased individually or as part of one of Euroclad Elite Systems.

Euroclad recommends the use of standard 0.4mm gauges for wall systems and 0.7mm gauges for roof systems. Should there be a requirement for other gauges, please contact the Euroclad Sales Office for availability.

Euroclad manufacture all liner sheets from Corus Colorcoat® lining enamel. The standard colour available is referred to as 'bright white'.

Translucent sheets can be supplied to match all Euroclad liner sheets. Liners are also available as crimped, curved sections – giving huge flexibility of application to fit most requirements.

Euroclad liner sheets have been designed to span up to 2,000mm in 0.4mm gauge material. It should be noted that unlike other designs of liner which can gape significantly between purlins, correctly installed Euroclad liner sheets in standard 0.4mm gauge material will not encounter this problem, preventing the need for specification of 0.5mm and 0.55mm gauge material.

Euroclad liner sheets, when fixed in accordance with our recommendations, meet the requirements of the Construction Design and Management Regulations (CDM).

However, as with all material, great care must be exercised in installation to guarantee a satisfactory end product.

TYPICAL CONSTRUCTION DETAIL

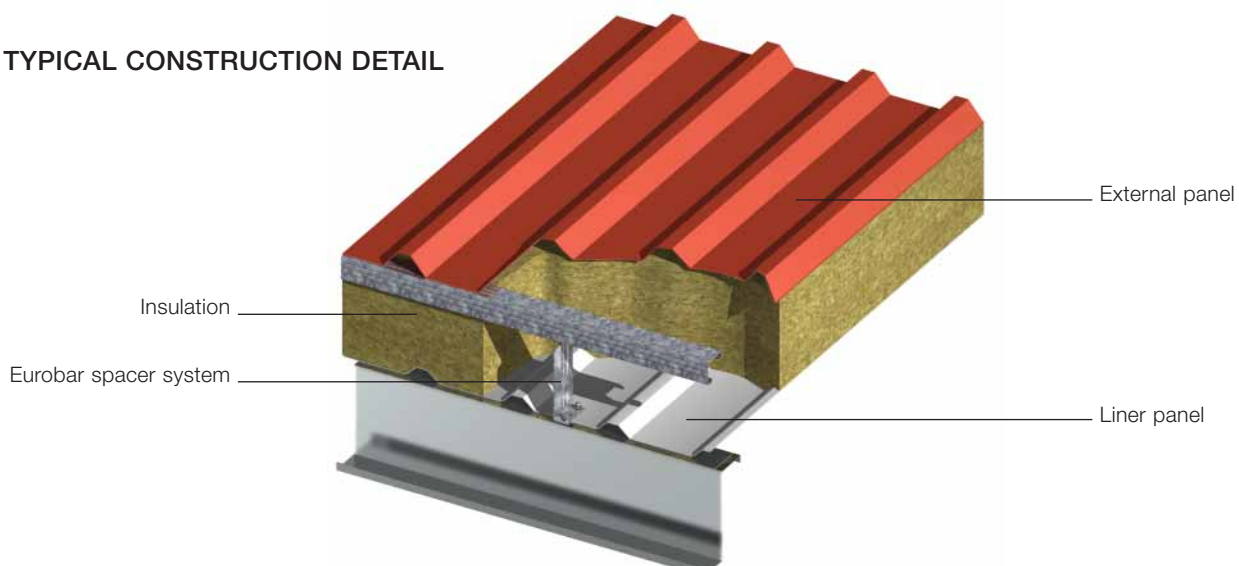

LINER CLADDING PROFILES

19/1000mm Liner

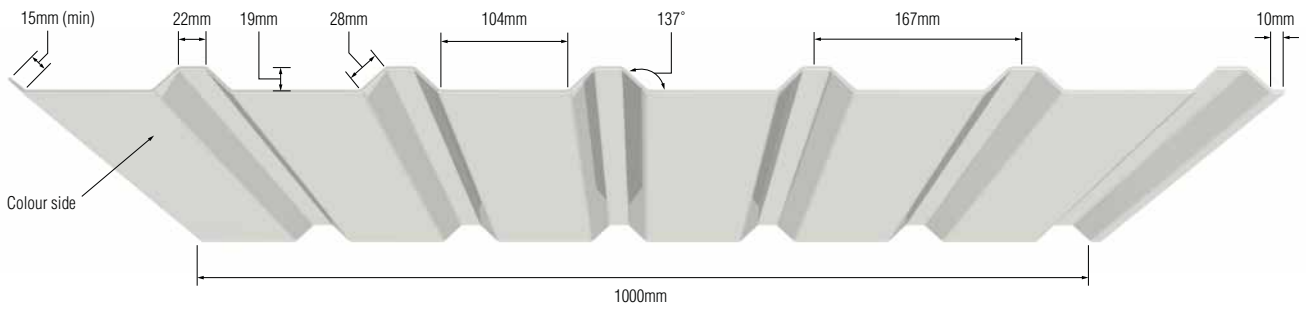

20/1066mm Liner

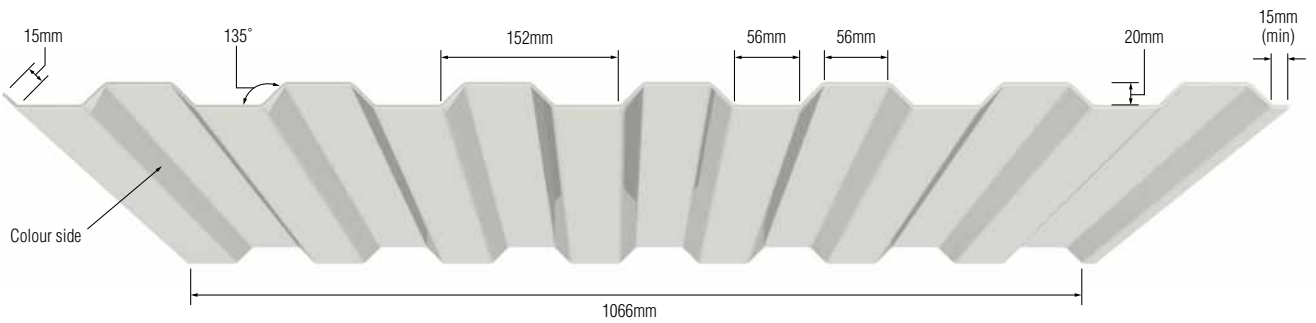

MW5L Liner

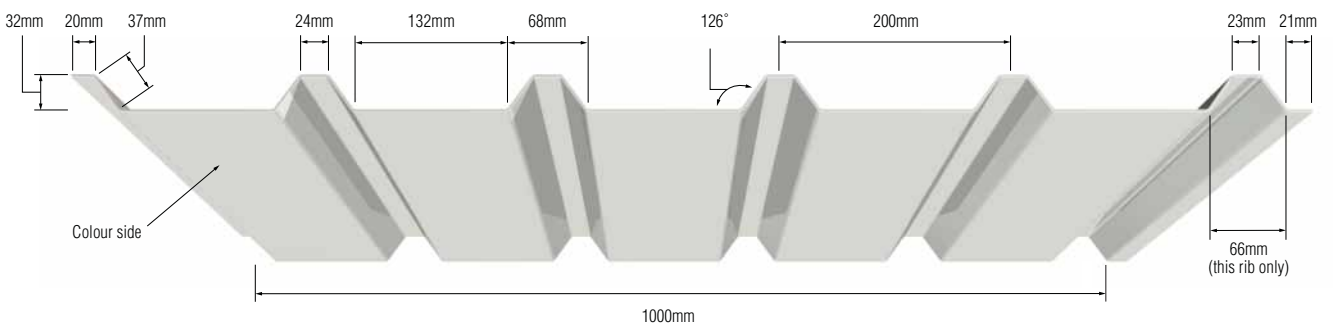

20/914mm Liner

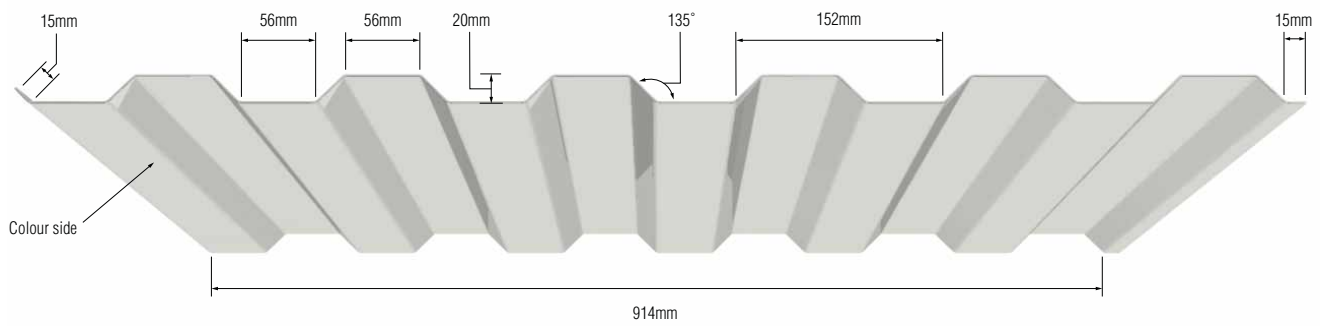

32/1000mm Liner

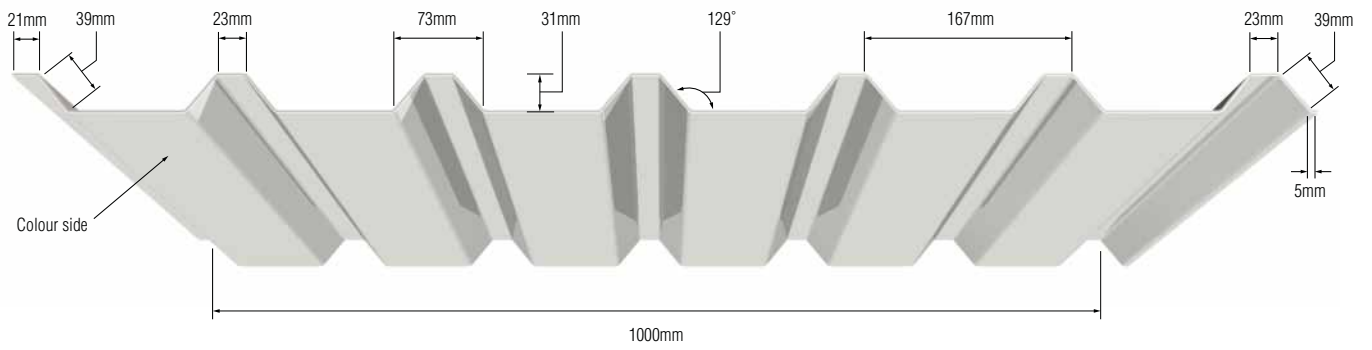

PRODUCT REFERENCE

INSTANT REFERENCE

Gauges	19/20 and 32/38 as standard offer and drawings	
Cover widths	914mm, 1000mm and 1066mm	
Maximum recommended length	6,500mm	
Maximum span	2,000mm	
Weight	0.4mm	20/914 = 3.215kg/Lm 19/1000 = 3.498 Kg/Lm 20/1066 = 3.764 Kg/Lm
	0.7mm	MW5L = 6.753 Kg/Lm
Standard colour	Bright white	
Finish	Lining enamel	
Substrate	Z275, hot dipped galvanised to BS EN 10 147, Fe E 220g	

Euroclad manufacture all liner sheets from Corus Colorcoat® lining enamel, a full specification of which can be found at www.euroclad.com.

Euroclad constructions offer an economic, lightweight alternative to other methods of internal lining. The durability and strength of pre-finished steel assists the speed of on-site construction.

Euroclad liner sheets form an integral part of Elite Systems, which offer specific performance and a 12 or 25 year guarantee.

1. COLOUR AND FINISH

The standard colour available is bright white (S5900) Corus Colorcoat® lining enamel, which provides optimum light reflectively, together with a hard, smooth, easily cleaned finish. For colour matching purposes, the nearest reference is BS 22-B-15.

2. FIRE CLASSIFICATION

Euroclad liner panel sheets have a Class 1 rating in relation to Surface Spread of Flame, to BS 476 (B):Part 7 and achieves a 'Class 0' surface rating for the purposes of the 'Building Regulations'.

Euroclad liner sheets, in conjunction with euroclad external sheets and insulation can be constructed to provide a fire resistant wall. Please refer to the 'Firewalls brochure' for further details.

3 THERMAL PERFORMANCE

Please refer to 'Design and Installation Recommendations' for insulation depths to meet specific U-value requirements.

4. ROOF LIGHTS

In normal circumstances Euroclad only recommend the use of GRP rooflights for which there are matching profiles available.

Internal rooflights are usually supplied in SAA1 grade to meet the requirements of Part B4 (External Fire Spread) of the Building Regulations (Fire Safety).

Because of the necessity to seal all penetrations effectively, Euroclad recommend that factory sealed rooflights are not used, as, in our opinion, it is far easier and more secure to install a site assembled rooflight system.

5. SPACER

The over rail built up system is typically the Eurobar or Eurobar Extra spacer.

Various bracket types and sizes are supplied by Euroclad, full details are available from the 'Eurobar' brochure.

6. LINER SEALED AT MANUFACTURERS RECOMMENDATIONS

With the new focus on airtightness, the effective sealing of the liner in both built-up and composite constructions is fundamental to the system performance.

Both in controlled small-scale tests and in practical air permeability tests in actual buildings, the metal liner, when correctly sealed, has successfully passed the Building Regulations criteria for Air Permeability.

The specification for sealing Euroclad liner sheets is as follows:

A. Side lap sealing	50mm x 1mm butyl sealing strip (polybond or similar)
B. End lap sealing	4mm butyl mastic bead, or a 6mm x 2mm, or 9mm x 3mm rectangular section is recommended, fixed in each trough

- Position the sealant in straight, unbroken lines covering the sheet laps.
- Place the sealant into the corrugations or troughs.
- Do not over stretch the sealant.
- Ensure continuity and effectiveness of seal, especially at the corners of sheets and at all penetrations of pipes, ducts, rooflights etc.

The BRE also advise careful sealing of all penetrations and the provision of adequate ventilation. Taking into account these two factors, Euroclad recommend that if rooflights are required they should be built up on site and not be factory sealed.

7. COVER WIDTHS

Euroclad liner profiles are primarily designed for use in conjunction with euroclad exterior profiled sheets and are, therefore, available in cover widths of 914mm and 1,066mm in the 20mm profile and 1,000mm in the 19mm, MW5 and 32mm profiles.

8. FILLERS

Black/white UV resistant polyethylene foam fillers are available for use as closures at the ends of the liner panels and at openings such as rooflights.

9. CURVING

The liner profiles are all suitable cranked curving and can be curved to any radius above 300mm. Please refer to the 'Curved roof and wall cladding profiles' brochure for further information.

10. FIXINGS

See the 'Design and installation recommendations' brochure for further information.

11. FRAGILITY

Can be classified as 'non-fragile' when installed as detailed in 'Guide to non-fragile installation of Euroclad profiles' (new document).

CORUS COLORCOAT® PRODUCTS AND SERVICES

To ensure the long-term performance and appearance of the building, it is important that the pre-finished steel product is specified alongside the cladding system.

Corus Colorcoat® Products and Services

The Colorcoat® brand provides the recognised mark of quality and metal envelope expertise exclusively from Corus. Over the course of 40 years Corus has developed a range of technically leading Colorcoat® pre-finished steel products which have been comprehensively tested and are manufactured to the highest quality standards. These are supported by a range of services such as comprehensive guarantees, colour consultancy and technical support and guidance.

Colorcoat HPS200® Ultra

The latest generation product for roof & wall cladding, Colorcoat HPS200® Ultra offers an exciting new colour range and dramatically improved colour and gloss performance. Maintenance and inspection free, Colorcoat HPS200® Ultra delivers twice the colour and gloss retention of standard plastisols, and is now guaranteed for up to 40 years, combining outstanding performance with unrivalled reliability.

Colorcoat Prisma®

The ideal choice to deliver eye-catching buildings that will stand the test of time. Technically and aesthetically superior to PVDF (PVF2), Colorcoat Prisma® is readily available in the most popular solid and metallic colours. All backed up with the unique Confidex® Guarantee providing cover for up to 25 years.

Repertoire® Colour Consultancy

The Repertoire® Colour Consultancy can advise on colours and colour strategies using a range of standard shades, as well as discussing individual bespoke colour requirements. Corus can match almost any shade from physical swatches to commonly used references such as RAL, NCS and British Standard and more unusual standards.

Confidex® Guarantee

Offers the most comprehensive guarantee for pre-finished steel products in Europe and provides peace of mind for up to 40 years. Unlike other guarantees, Confidex® covers cut edges for the entirety of the guarantee period and does not require mandatory annual inspections.

Confidex Sustain®

Offers the first CarbonNeutral building envelope in the world. It provides a combined guarantee which covers the durability of the Colorcoat® pre-finished steel product and guarantees to offset unavoidable CO₂ emissions from the pre-finished steel and Colorcoat® assessed cladding system, including fixings and insulation, from cradle to cradle. More than just offsetting, the aim is to encourage specification of the most sustainable pre-finished steel products and cladding systems.

Colorcoat® Building Manual

Developed in consultation with architects and other construction professionals, the Colorcoat® Building manual incorporates over 40 years of Colorcoat® expertise. It contains information about sustainable development and the creation of a sustainable specification.

Colorcoat® Technical Papers

Working closely with the Corus Colorcoat® Centre for the Building Envelope based at Oxford Brookes University and the Steel Construction Institute, Corus has produced a number of Technical Papers. These address key construction issues such as the creation of an airtight building envelope and end of life options for pre-finished steel cladding systems.

For more information about Corus Colorcoat® products and services visit www.colorcoat-online.com or call the Colorcoat Connection® helpline on +44 (0)1244 892434.

Corus Colorcoat HPS200® and Colorcoat Prisma® pre-finished steel in Blue, Sirius and Goosewing Grey.



Corus Colorcoat HPS200® pre-finished steel in Augusta Green.



Euroclad Limited

Wentloog Corporate Park
Cardiff
CF3 2ER

Telephone +44 (0)29 2079 0722
Facsimile +44 (0)29 2079 3149
E-mail sales@euroclad.com
Internet www.euroclad.com

Euroclad (Ireland) Limited

Unit 4
Newhall Industrial Estate
Naas
Co. Kildare

Telephone 00 353 (0) 45 435 470
Facsimile 00 353 (0) 45 435 472
Internet www.euroclad.ie

