



The Counting Cashbox

A combination of skimming, detecting and counting in one solid safe.



The MCC is a unique combination of a 100% ECB detection device and an intelligent storage in one solution.

With a bracket you can easily mount it in a checkout where it stores all the notes fast and secure in a handy portable container. You can choose to mount it in a way you can always check the display for the total count or you can choose to slide the system forward in order to read it.

By the two lockable compartments you can choose to take away the whole cashbox without touching its contents. This can be desired in case of a third (CIT) party for pick up or somebody who just transports the boxes inside the building. You can also choose to empty the box at the till directly and leave the whole compartment at the cash desk.

In any case after your shift you will know instantly how much is in the cashbox and you can do a straight deposit without a further count!



easy to open



easy to transport



already counted



easy to carry with the portable container

Specifications:

- Screws for mounting are included.
- Easy to install yourself.
- External measures in mm: (h x b x d): 340 x 140 x 430.
- Thickness: 2mm.
- Weight: 7 kg.
- Extra containers deliverable from stock.



SECURITY FIRST. SERVICE SECOND TO NONE.

100% ECB MT2158 detector



Air Tube Services Ltd
Commercial House, 23 Meadow Road, Netherfield, Nottingham NG4 2FR

Cash Trolley

The base of the trolley has a **wide opening cash door** that remains locked whilst the cash collection is made. It is recommended the keys for this lower door are not to be taken when collecting the money.

The cash is collected in a sturdy **internal cash collection box** that holds the cash safely in place whilst in transit. The cash access door can be opened once safely delivered.

Each trolley comes with an **angled steer handle**, and a **secure chain wrist attachment**, which can activate a high pitch alarm if there is any attempt to steal the money.

Mk 1 is for note and coin collection.

Mk 2 is a long wheelbase trolley, for note and heavy coin load.

Mk 3 is as Mk1, but incorporating a top section permitting distribution of cash floats to staff tills.

Mk's 1 & 2 offer a **choice of alarm protection** as an optional extra; Mk3 incorporates an alarm as standard

MK1 Trolley

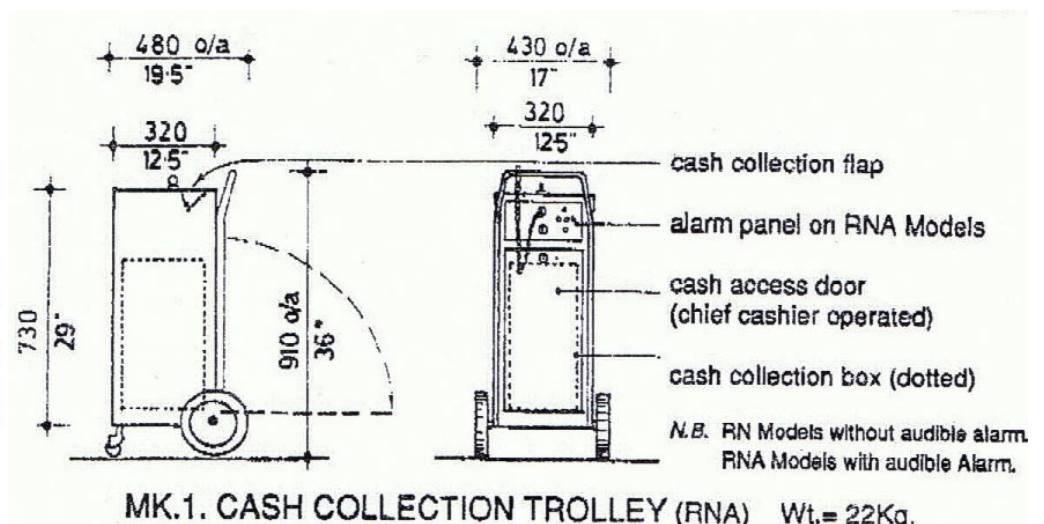

MK2 Trolley

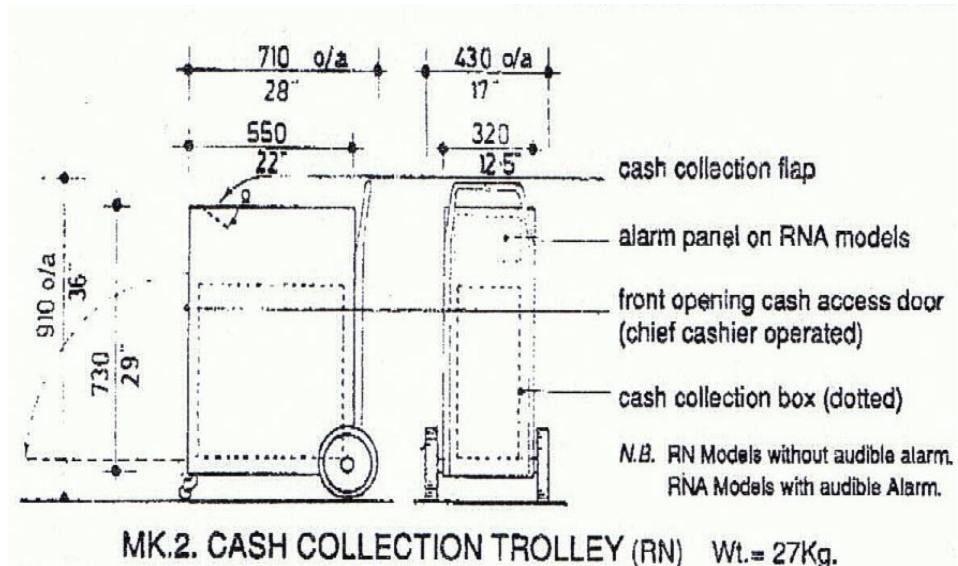

MK3 Trolley

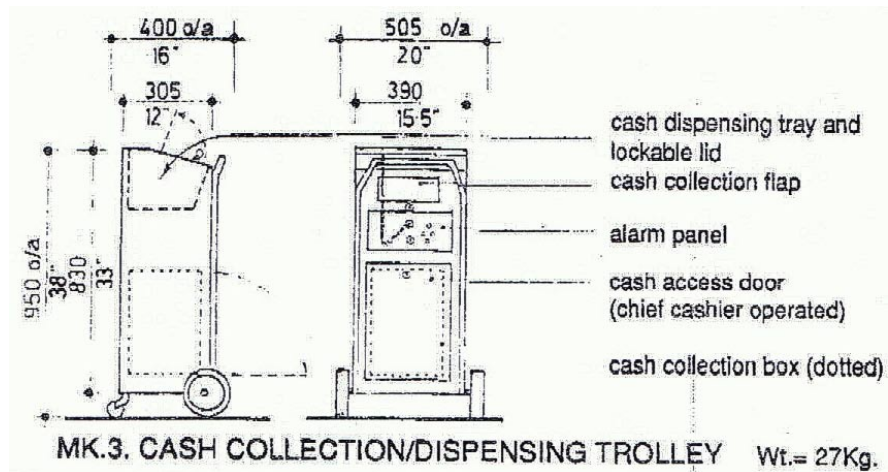

Web : www.airtubeservices.co.uk

Tel : 0115 9611 911 Email : sales@airtubeservices.co.uk

Air Tube Services Ltd, 23 Meadow Road, Netherfield, Nottingham, NG4 2FR

SECURITY FIRST. SERVICE SECOND TO NONE

