

density  
2.7 g/ml

% efficiency	Particle Size
0	0
	1
	2.5
10	5
20	7.5
34	10
50	15
62	20
73	25
83	30
90	40
97	50
98	60

Standard Grade w.c.  
test dust . Silica  
Powder

Analysis Microns	% of mass by weight
104-150	3
75-104	7
60-75	10
40-60	15
30-40	10
20-30	10
15-20	7
10-15	8
7.5-10	4
5-7.5	6
2.5-5	8
< 2.5	12

### ME CYCLONES EFFICIENCY

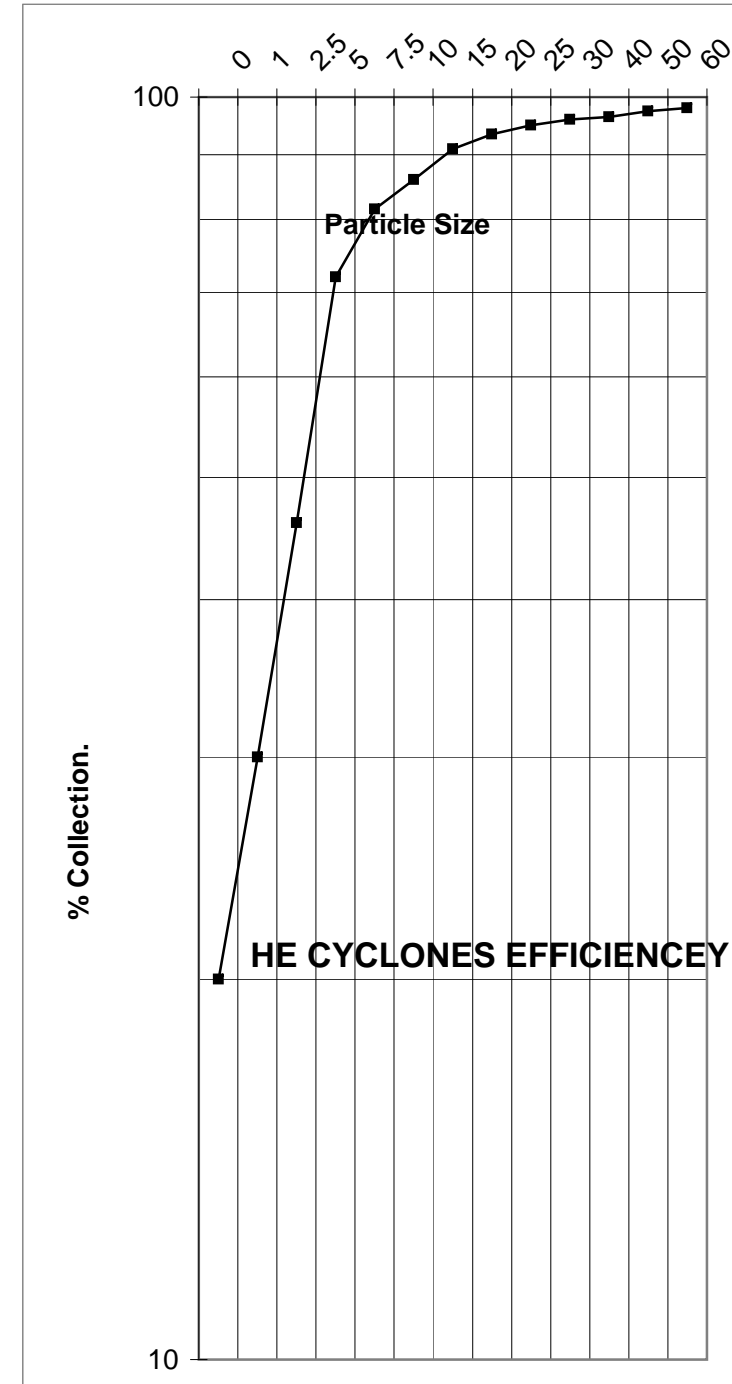
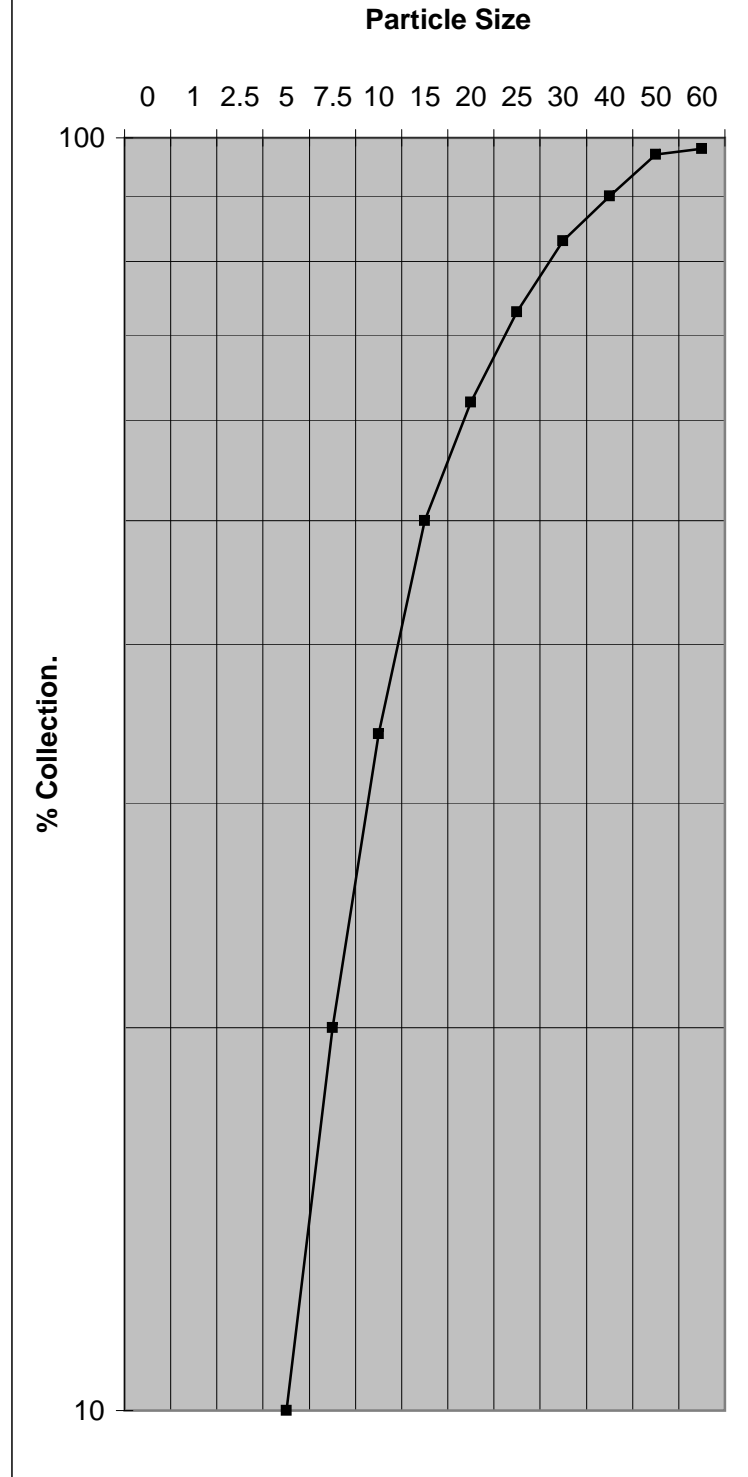

% efficiency	Particle Size
20	0
30	1
46	2.5
72	5
81.5	7.5
86	10
91	15
93.5	20
95	25
96	30
96.5	40
97.5	50
98	60

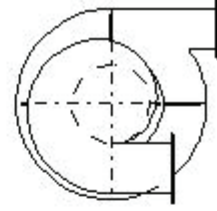
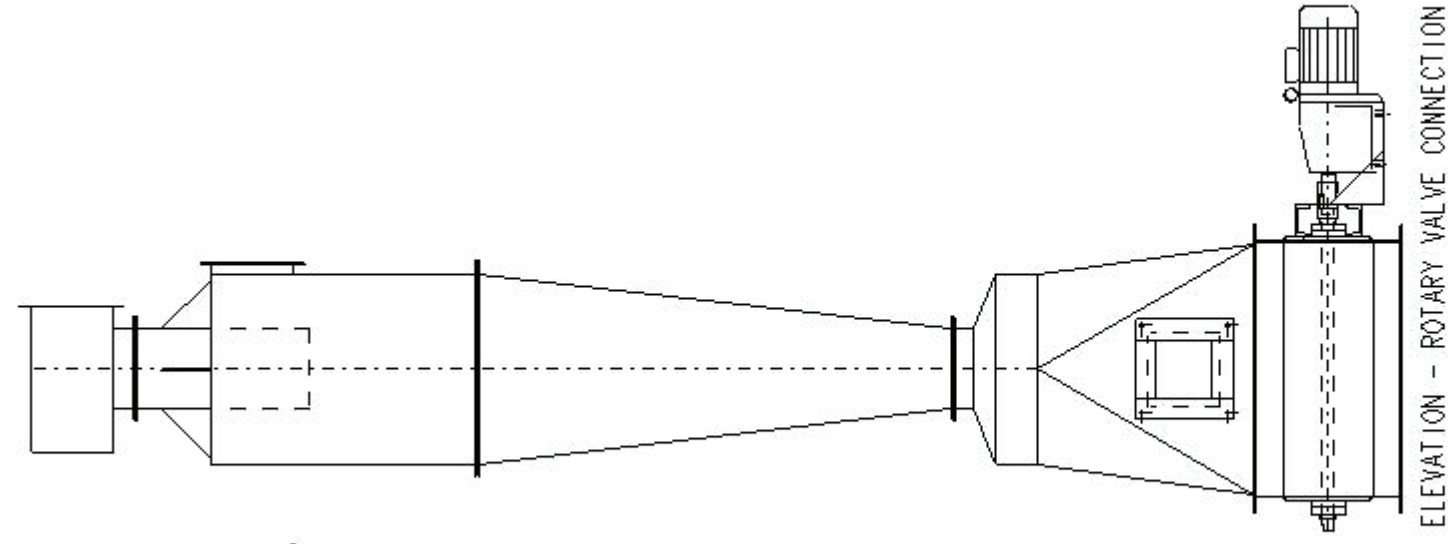
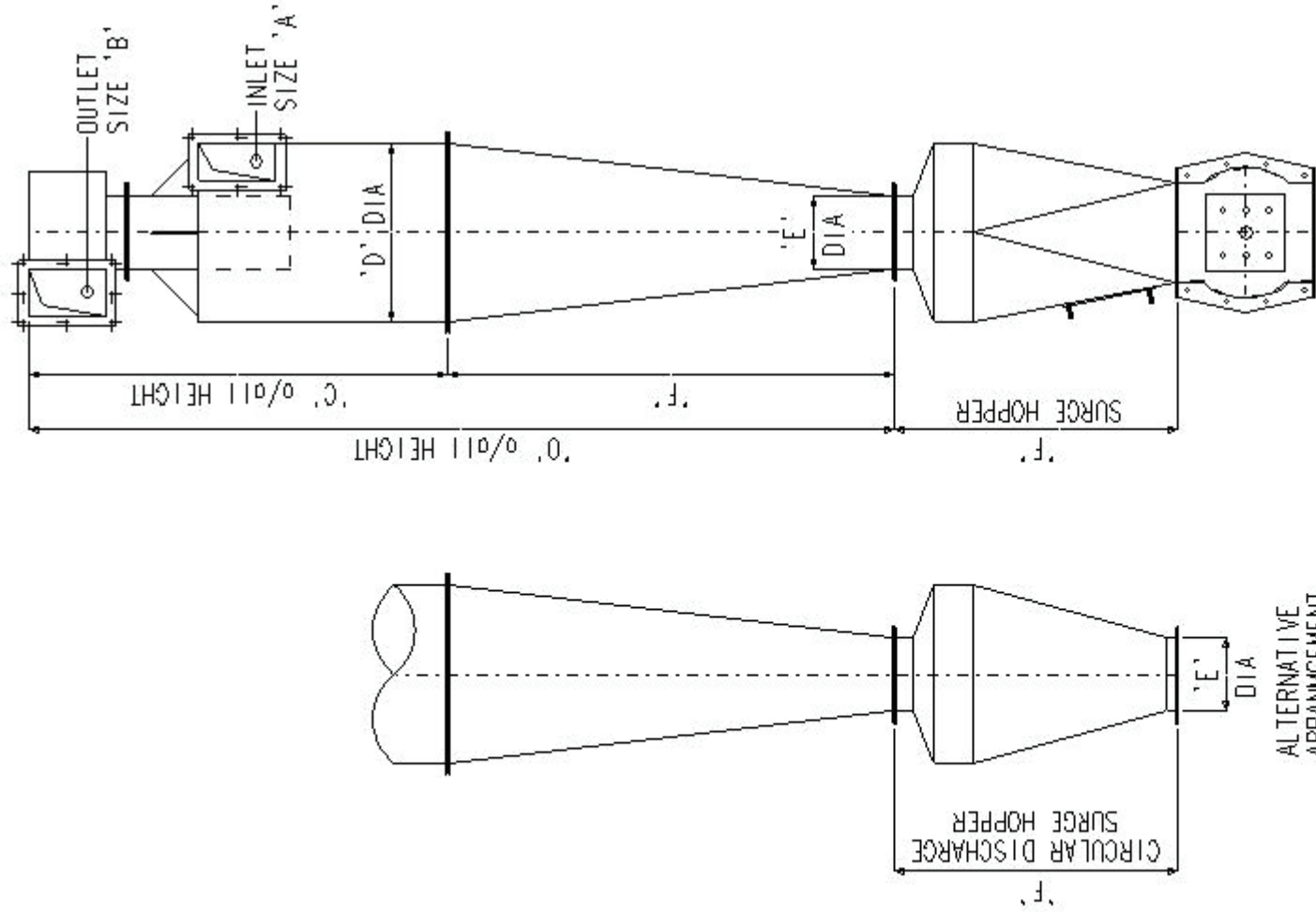

PLAN VIEW

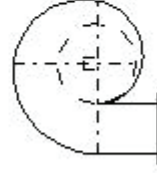

PLAN VIEW OF  
OUTLET VOLUTE

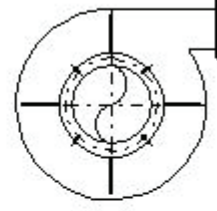

SECTIONED PLAN VIEW  
OF INLET VOLUTE

'H' TYPE HIGH EFFICIENCY CYCLONES