

# LX Series

## Diesel and LP Gas Forklift Trucks

2,000kg and 2,500kg

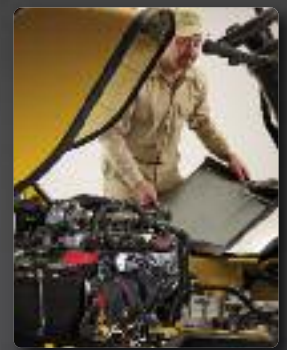

- Designed for medium duty applications, up to 1000 hours per year
- 2,000kg or 2,500kg capacities, Diesel or LPG power
- Electronic Powershift transmission delivers fast load handling
- Proven components ensure excellent reliability and high productivity

**Yale**   
People. Products. Productivity.

## Truck Dimensions

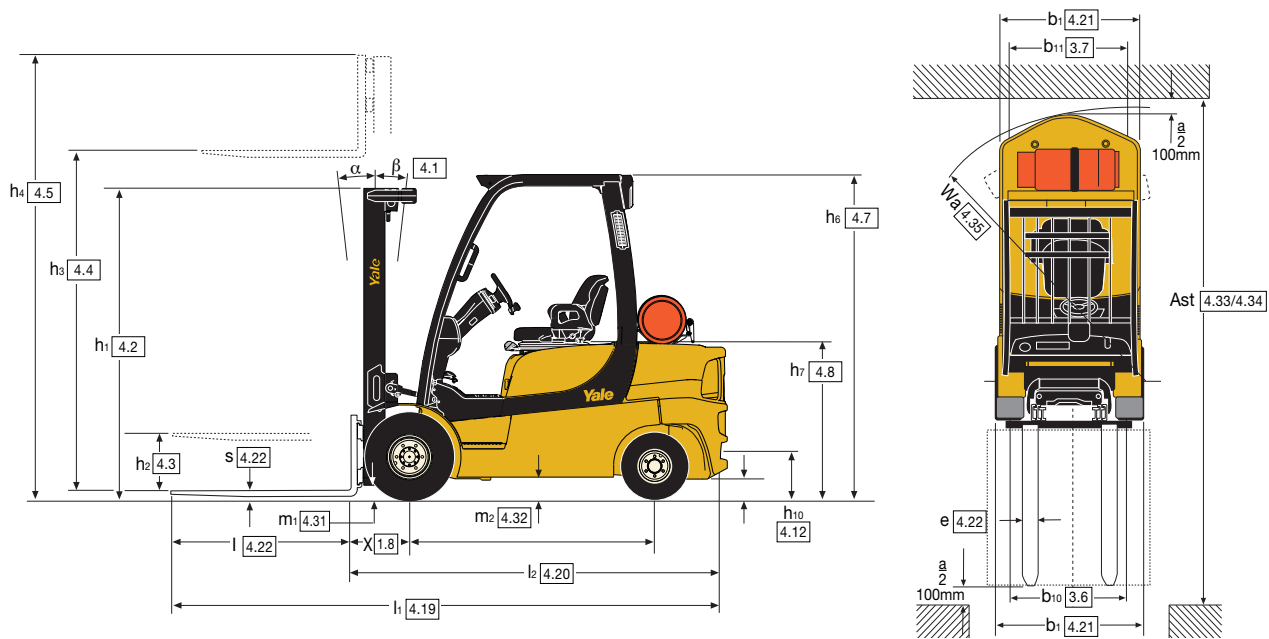

## GDP20LX, GLP20LX, mast details and capacity ratings (kg) - Supercushion tyres

Masts	Overall Lowered Height (OAH) h1	Maximum Lift Height (MFH) h3+s	Tilt		Capacity @ maximum lift height		Lift height @ maximum capacity			
			F	B	Standard Carriage (kg)	Integral Sideshift	Lift Height (mm)	Standard Carriage (kg)	Lift Height (mm)	Integral Sideshift (kg)
3 Stage FFL (E)	2049	4325	5	5	2000	1900	4325	2000	4325	1900
	2199	4775	5	5	1800	1760	4300	2000	4300	1900
	2299	5075	5	5	1500	1460	4250	2000	4250	1900

## GDP25LX, GLP25LX, mast details and capacity ratings (kg) - Supercushion tyres

Masts	Overall Lowered Height (OAH) h1	Maximum Lift Height (MFH) h3+s	Tilt		Capacity @ maximum lift height		Lift height @ maximum capacity			
			F	B	Standard Carriage (kg)	Integral Sideshift	Lift Height (mm)	Standard Carriage (kg)	Lift Height (mm)	Integral Sideshift (kg)
3 Stage FFL (E)	2049	4325	5	5	2500	2400	4325	2500	4325	2400
	2199	4775	5	5	1930	1900	4300	2500	4250	2400
	2299	5075	5	5	1610	1570	4200	2500	4150	2400

Capacity in kg @ 500 mm load centre. Equipped with 1000 mm forks and supercushion tyres.

## Application Guide

Attributes	GDP/GLP20LX	GDP/GLP25LX
Operation	Low intensity applications	Low intensity applications
Typical Shifts per Day	1 shift, light 2nd shift	1 shift, light 2nd shift
Typical Hours per year	Up to 1000	Up to 1000
Typical Operation Frequency	Intermittent	Intermittent
Duty Cycle Levels	Moderate	Moderate
Ramp Usage	Occasional	Occasional
Fuel Type	Diesel / LPG	Diesel / LPG
Standard Engine	2.0L	2.6L
Engine Power	29,1kW	30,2kW
Mast Types	3-Stage Full Free Lift	3-Stage Full Free Lift
Attachment Compatibility	Carriage or Sideshift only	Carriage or Sideshift only
Hydraulic Functions	1 auxiliary function, available with Sideshift only	1 auxiliary function, available with Sideshift only
Travel Speeds (with load, km/h)	16,9 / 17,4	16,9 / 17,4
Ast 1000 mm x 1200mm wide	3563 mm	3624 mm
Lift Speed with load (m/s)	0,42 / 0,43	0,41 / 0,42
Gradeability laden @1,6 km/h	29,3% / 25,1%	26,1% / 22,5%

# VDI 2198 - General Specifications

		Yale		Yale		Yale		Yale		
Characteristics	1.1	Manufacturer		Yale		Yale		Yale		
	1.2	Model designation		GDP 20 LX		GDP 25 LX		GLP 20 LX		
	1.3	Power: battery, diesel, LPG, electric mains		Diesel		Diesel		LPG		
	1.4	Operation: manual, pedestrian, stand, seat, orderpicker		Seat		Seat		Seat		
	1.5	Load capacity	Q (kg)	2,000		2,500		2,000		
	1.6	Load centre	c (mm)	500		500		500		
	1.8	Load distance	x (mm)	388		388		388		
	1.9	Wheelbase	y (mm)	1623		1623		1623		
	Weights	2.1	Unladen weight	kg	3400		3675		3240	
2.2		Axle loading with load, front/rear	kg	4806 / 594		5635 / 540		4727 / 513		
2.3		Axle loading without load, front/rear	kg	1712 / 1688		1630 / 2045		1632 / 1608		
Wheels and Tyres	3.1	Tyres: L = Pneumatic, V = Solid, SE = Supercushion		SE		SE		SE		
	3.2	Tyre size, front		6.5 X 10-10		6.5 X 10-10		6.5 X 10-10		
	3.3	Tyre size, rear		18 X 7-8		18 X 7-8		18 X 7-8		
	3.5	Number of wheels, front/rear (X = driven )		2 x / 2		2 x / 2		2 x / 2		
	3.6	Track width, front	b10 (mm)	978		978		978		
	3.7	Track width, rear	b11 (mm)	895		895		895		
	Dimensions	4.1	Mast tilt, forward $\alpha$ /back $\beta$	degrees	5 / 5		5 / 5		5 / 5	
4.2		Height of mast, lowered	h1 (mm)	2049		2049		2049		
4.3		Free lift $\blacktriangle$ $\blacklozenge$	h2 (mm)	1554		1554		1554		
4.4		Lift height $\blacktriangle$	h3 (mm)	4325		4325		4325		
4.5		Height of mast, extended $\blacklozenge$	h4 (mm)	4820		4820		4820		
4.7		Height to top of overhead guard $\circ$	h6 (mm)	2149		2149		2149		
4.8		Seat height $\times$	h7 (mm)	1044		1044		1044		
4.12		Towing coupling height	h10 (mm)	330		330		330		
4.19		Overall length	l1 (mm)	3426		3491		3426		
4.20		Length to face of forks	l2 (mm)	2426		2491		2426		
4.21		Overall width (Standard / Wide / Dual)	b1/b2 (mm)	1147		1147		1147		
4.22		Fork dimensions	s/e/l (mm)	40 x 100 x 1000		40 x 100 x 1000		40 x 100 x 1000		
4.23		Fork carriage to DIN 15173. Class, A/B		IIA		IIA		IIA		
4.24		Fork carriage width $\blacktriangleright$	b3 (mm)	977		977		977		
4.31		Ground clearance under mast, with load	m1 (mm)	98		98		98		
4.32		Ground clearance at centre of wheelbase	m2 (mm)	127		127		127		
4.33		Aisle width with pallets 1000mm long x 1200mm wide $\bullet$	Ast (mm)	3563		3624		3563		
4.34		Aisle width with pallets 800mm wide x 1200mm long $\bullet$	Ast (mm)	3763		3824		3763		
4.35		Outer turning radius	Wa (mm)	2175		2236		2175		
4.36	Inner turning radius	b13 (mm)	103		103		103			
Performance	5.1	Travel speed with/without load	km/h	16.9	17.0	16.9	17.0	17.4	18.0	
	5.2	Lifting speed with/without load	m/s	0.42	0.52	0.41	0.52	0.43	0.50	
	5.3	Lowering speed with/without load	m/s	0.50	0.43	0.50	0.43	0.49	0.42	
	5.5	Drawbar pull with/without load @ 1.6km/h	kN	14.2	8.8	14.0	9.5	12.3	8.8	
	5.6	Maximum drawbar pull with/without load	kN	16.6	8.8	16.4	9.5	14.7	8.8	
	5.7	Gradeability with/without load @ 4.8km/h $\blacksquare$	%	20.1	27.3	15.0	27.3	16.7	27.3	
	5.8	Maximum gradeability with/without load @1.6km/h $\blacksquare$	%	29.3	27.3	26.1	27.3	25.1	27.3	
	5.10	Service brake		Hydraulic		Hydraulic		Hydraulic		
	Motors	7.1	Engine manufacturer/type		Yanmar		Yanmar		Mazda	
		7.2	Engine output, in accordance with ISO1 585 / DIN 6271	kW	29.1		29.1		30.2	
7.3		Governed speed	rpm	2400		2400		2400		
7.4		Number of cylinders/displacement	cm <sup>3</sup>	4 / 2659		4 / 2659		4 / 1998		
7.5		Fuel consumption in accordance with VDI cycle	l/hr or kg/hr	2.9		3.3		2.7		
Other	8.1	Drive control		Automatic		Automatic		Automatic		
	8.2	Working pressure for attachments	bar	N/A		N/A		N/A		
	8.3	Oil flow for attachments	l/min	N/A		N/A		N/A		
	8.4	Average noise level at operator's ear $\star$	dB(A)	79		79		79		
		Guaranteed sound power 2001/14/EC	dB	102		102		102		
8.5	Towing coupling type / DIN type		Pin		Pin		Pin			

$\star$  Measured according to the test cycles and based on the weighting values contained in EN12053.

$\blacktriangle$  Top of forks

$\times$  Full-suspension seat in depressed position

$\blacktriangleright$  Add 32 mm with load backrest

$\blacklozenge$  Without load backrest

$\circ$  h6 subject to +/- 5 mm tolerance

$\bullet$  Stacking aisle width are based on the V.D.I. standard calculation as shown on illustration. The British Industrial Truck Association recommends the addition of 100 mm to the total clearance (dimension a) for extra operating margin at the rear of the truck.

$\blacksquare$  Gradeability figures are provided for comparison of tractive performance, but are not intended to

endorse the operation of the vehicle on the stated inclines. Follow instructions in the operating manual regarding operation on inclines.

**Spec sheet truck based on:**  
4325mm (TOF) 3-stage full free lift mast with mast with standard carriage, 1000 mm forks with manual levers.

## LX Series

Models: GDP/GLP 20LX, 25LX

### Yale GDP/GLP20-25LX

Engineered to deliver high productivity in low intensity or medium duty applications, the new Yale GDP/GLP20-25LX series meets the requirements of users who require a cost-effective solution to their materials handling needs. The LX is designed to operate in moderate applications for short periods of time, or to conduct lighter duty work cycles for longer - typical operating hours are in the region of 500-1,000 hours per annum.

Available with either Diesel or LPG engines and in 2,000 or 2,500kg capacities only, the new LX has been configured for specific applications, giving customers the opportunity to acquire a truck that exactly meets their materials handling needs, but at a reduced level of investment.

### High Productivity

The new 20-25LX provides these customers with the performance characteristics they need, ensuring a high rate of productivity - the electronically controlled Powershift transmission delivers fast load handling and smooth direction changes. Loads can be positioned quickly and correctly thanks to the fast hydraulics and the optional integral sideshift and the responsive electronically-controlled inching adjustments gives the operator better control of load positioning.

### Operator Comfort

The more efficient operators are over the course of the shift, the more profitable the operation will be. Operator comfort is therefore key to maximizing productivity, so the LX driving position offers the ideal work place environment for operators, as well as excellent all-round visibility during handling operations.

Whole-body vibration levels are low thanks to the isolated powertrain and the standard full-suspension seat. Foot space is ample and all controls are in within easy reach - a 30cm diameter steering wheel with spinner knob, with an adjustable steering column offers infinite adjustments and comfort and the cowl-mounted hydraulic levers are precise and easy to operate. As drivers often need to get on and off the truck regularly during the shift, entry and exit

is made easy thanks to a simple 3-point entry system, with a low step height of 38cm.

### Reliable Operation

While carefully designed to operate efficiently in specific applications with moderate duty cycles, the LX still retains the innovative design and engineering, solid construction and reliability familiar to Yale users. Proven components, such as sealed electrical connectors, O-ring face seal fittings and a well-regarded durable powershift transmission, plus a simplified electrical system that retains the benefits of CANbus wiring, mean that - in the right application - LX models will deliver excellent reliability, ensuring maximum uptime, high productivity and reduced costs.

### Low Operating Costs

Furthermore, the LX offers exceptional value for money - An efficient 2.6L Diesel or 2.0L LPG engine, single-speed transmission and lighter overall weight help to maximise efficiency and deliver lower fuel costs, providing an ideal balance between the amount of loads moved and fuel used.

The use of right-sized, dependable components, reduced electronic complexity and a simplified list of options mean that over the lifetime of the truck, the savings continue to add up. With lower overall operating costs, the LX represents a cost-effective solution for medium-duty materials handling operations with lower operating hours.

### Easy Maintenance

Maintenance is made easy thanks to the complete cowl-to-counterweight service access, with a 65° opening hood and one-piece removable floor plate, helping to reduce downtime. Unplanned service can be kept to the minimum thanks to the use of proven, reliable components, such as sealed electrical connectors with IP66 rating against ingress of dirt and water, helping to keep your truck, and your operation, running smoothly.

As with all Yale products, the LX is supported by a dealer network which offers excellent geographical coverage and the most responsive service organization in the industry, delivering

after sales support that ensures that the maximum uptime is maintained.

### Application Types

Home Improvement Stores  
Wholesale and Retail Outlets  
Secondary Distribution  
Third Party Logistics  
Independent Retail

### Standard Features:

- 2.0L Mazda LPG or 2.6L Yanmar Diesel engine
- Powershift single speed transmission
- Drum brakes
- Supercushion tyres - Front 6.50 X 10-10 Rear 18 X 7-8
- Continuous Stability Enhancement system
- 3-stage Full Free Lift mast - 4350mm maximum fork height
- 5 degree forward / 5 degree back tilt
- 977mm Class II carriage
- 1000mm forks
- Vinyl full-suspension seat with seatbelt
- Cowl-mounted levers
- Direction lever
- 2150mm high Overhead Guard
- Rear reflectors
- Low diesel and LPG warning indicator
- Coolant temperature warning light

### Options

- Masts: 3-stage Full Free Lift: 4800mm, 5100mm
- Load Backrest
- 3rd hydraulic function (Integral Sideshift)
- 1100mm, 1200mm forks
- Semi-suspension vinyl seat
- Light Kit: rear brake lights, marker lights and reverse lights, Halogen front and rear worklights
- Amber LED strobe light-low or high mounted
- Back-up alarm
- Dual rearview mirrors
- Rear drive handle with horn button.



NACCO Materials Handling Limited trading as Yale Europe Materials Handling  
Flagship House, Reading Road North, Fleet, Hampshire GU51 4WD, United Kingdom.  
Tel: + 44 (0) 1252 770700 Fax: + 44 (0) 1252 770784  
[www.yale-forklifts.eu](http://www.yale-forklifts.eu)

Country of Registration: England. Company Registration Number: 02636775



**Safety.** This truck conforms to the current EU requirements. Specification is subject to change without notice.

Publication part no. 258985452 Rev.00  
Printed in The United Kingdom (0611HG) EN

Yale is a registered trade mark.  
© Yale Europe Materials Handling 2011. All rights reserved.  
Truck shown with optional equipment