



# METALLIC SEALS

**Metal O Rings**  
**Metal C Rings**  
**Spring Energised Metal C Rings**  
**Metal E Ring Seals**



MOONTOWN LTD  
SEALING SYSTEMS BROCHURE





To compliment our already successful Spring Energised PTFE seal range, Moontown offers a range of Metallic sealing products for the most demanding sealing applications where temperature/radiation/corrosion/permeability etc may preclude the use of PTFE and elastomeric seals.

Manufactured in a range of high quality alloys and stainless steel, our metallic seals can be used for gas and liquid mediums.

Included in our range are metal O rings; metal C rings; spring energised metal C rings and metal E ring seals.

These products are offered in a choice of materials/cross sections and material thicknesses to cover a wide range of application duties. Various coatings are also available to enhance sealing capabilities.

Most of these products are supplied in circular form but we can also offer special shaped solutions subject to meeting some minimum engineering qualifications.

We can also offer our U seal Radial design which is specially manufactured for applications where there is a small degree of linear movement, such as with expansion joints. This seal is designed on request.

Typical applications for our metal seals are;

- Pumps
- Oil and gas
- Chemical
- Diesel/Automotive engines
- Aerospace/Aero Engines
- Plastic molding
- Reactors/Nuclear Installations
- Accelerators
- High vacuum
- Valves
- Compressors
- Heat exchangers
- Research Equipment



Please contact us with details of your sealing requirement.



## METAL 'O' RING SEALS

### Description and Applications of Metallic "O" Ring Seals

The Moontown O-Ring Seals are used when elastomers and other non metallic seals will not seal properly or do not offer the required reliability for the application, usually as a result of temperatures, pressures, or the environment. Moontown O-Ring Seals are long lasting seals and unlike non-metallic seals, they are not subject to failure due to incompatibility with the environment, out gassing or from deterioration due to age.

Moontown O-Ring Seals are generally fabricated from tubing. Typical tubing material consists of stainless steel or high temperature alloys such as inconel. These materials are frequently used because they offer resilient properties that enable the seal to "Spring-Back".

Moontown O-Ring Seals are used as static face type seals and should not be used as a dynamic seal. While the majority of seals are circular, many seals are produced in rectangular, racetrack and other various shapes and configurations.

We welcome the opportunity to design a seal to fit your application. Whether you are sealing gases or liquid -253°C or 1100°C vacuum to 3450 BAR. We have the capability to produce a suitable seal from available material.

The following are key elements in specifying the proper seal determining the base material:

- Temperature Limits/Duration
- System Pressure
- Media to be sealed
- Available Seating Load

#### Plating and Coatings

Plating or Coating of the O-Ring Seal provides a soft malleable surface that will smear into small imperfections in the mating hardware. Enhancing seal performance

#### Shaped Seals

Metallic O-Ring Seals can be produced in various shapes. The availability of shaped O-Ring permits the design engineer to select the shapes; However, it is recommended to contact our Technical Service staff for design assistance of seal and groove.

#### Suggested minimum Radii for shaped seals

Free Height	Min. Radius	Free Height	Min. Radius	Free Height	Min. Radius
0.89	3.18	3.18	19,00	6.35	101,60
1.57	6.35	3.96	38,10	9.53	152,40
2.39	12,70	4,78	50,80	12,70	254,00



**INTERNAL PRESSURE EXHIBIT A**

SEAL		
C		A
Free Height	Tol.	OD Range
0,89	+0,076 /- 0,025	9,52 – 44,45
1,57	+0,076 /- 0,025	10,3 – 101,6
2,39	+0,076 /- 0,025	25,4 – 304,8
3,18	+0,076 /- 0,025	50,8 – 1016,6
3,96	+0,100 /- 0,000	76,2 – 914,4
4,77	+0,127 /- 0,000	101,6 – 1219,2
6,35	+0,127 /- 0,000	152,4 – 1828,8
9,53	+0,127 /- 0,000	304,8 – 3048,0
12,7	+0,152 /- 0,000	610,0 – 3048,0

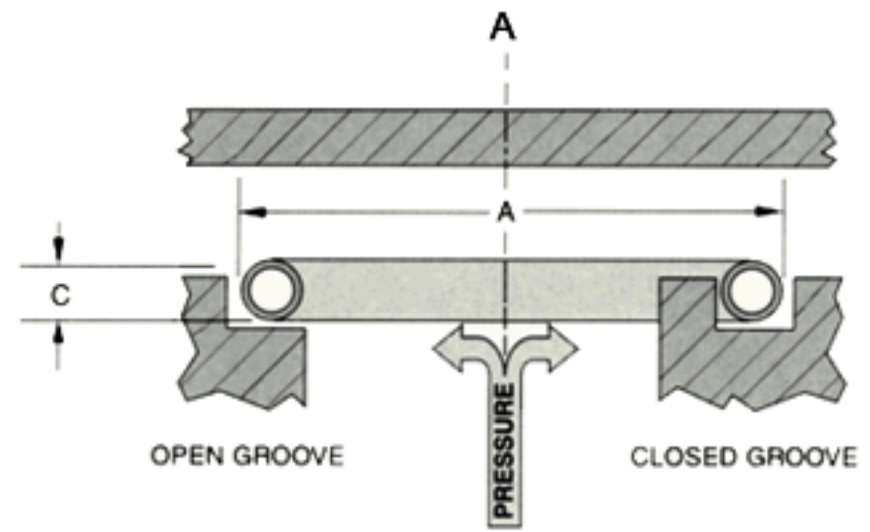
**EXTERNAL PRESSURE EXHIBIT B**

SEAL		
C		A
Free Height	Tol.	D Range
0,89	+0,076 /- 0,025	9,52 – 44,45
1,57	+0,076 /- 0,025	10,3 – 101,6
2,39	+0,076 /- 0,025	25,4 – 304,8
3,18	+0,076 /- 0,025	50,8 – 1016,6
3,96	+0,100 /- 0,000	76,2 – 914,4
4,77	+0,127 /- 0,000	101,6 – 1219,2
6,35	+0,127 /- 0,000	152,4 – 1828,8
9,53	+0,127 /- 0,000	304,8 – 3048,0
12,7	+0,152 /- 0,000	610,0 – 3048,0

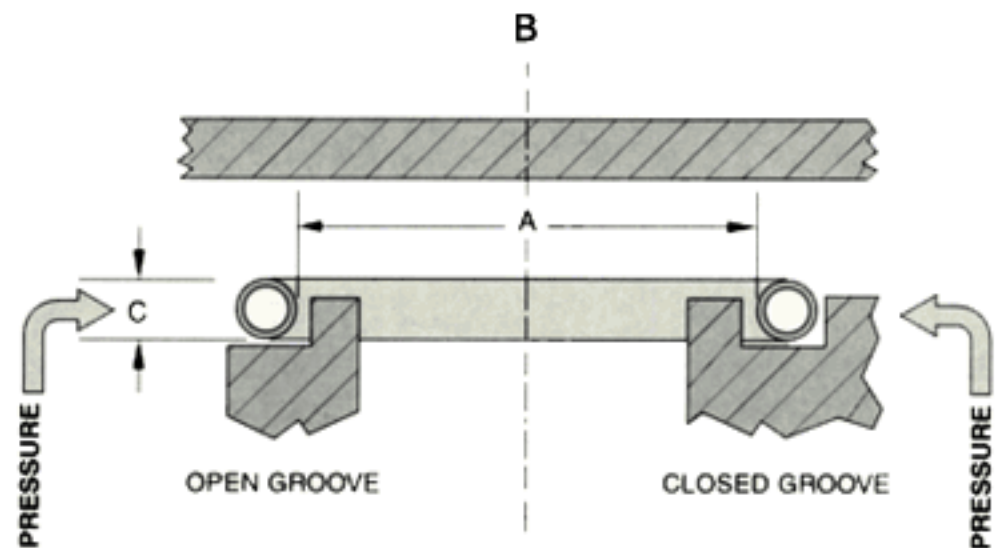
**Loading**

The seal is compressed to a predetermined height to optimize performance resulting in two uniform contact lines on the face of the seal. As the seal is compressed it deforms elastically to provide maximum resiliency allowing for maximum sealing.

**Venting**

For pressures over 70 BAR seals must be vented. In the vented condition the seal utilizes the system pressure to equalize the pressure within the seal, maintaining acceptable seal stresses and preventing the seal from collapsing.

**Sealing Surface Finish**

The groove and mating flange face must have a surface finish of 16 Ra for plated or coated seals. For gas and vacuum, a finish 4 to 8 Ra is recommended. Machining tool marks in groove or flange face must be concentric (circular lay). The seal and mating hardware surfaces must be free from dirt, grit and other foreign materials.

**O-Ring Seal Type**

Pressure will determine the type of seal that should be selected

**Plain**  
(Not Self-Energized or Pressure filled)

Made of metal tubing, usually stainless steel and Inconel alloys.

This is most economical O-Ring seal design. It is used for low to moderate pressure and vacuum applications

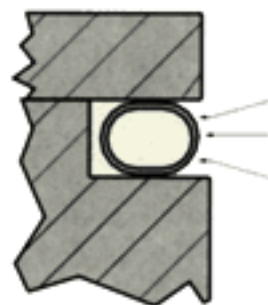
**Ultra-high Vacuum to 70 BAR:  
Non Self-energized****Self-Energizing**

The inner or outer diameter is vented with small holes or slots. The pressure equalizes with the system pressure by increasing the pressure inside the seal which enhances the performance by permitting the seal to exert increased pressure on the mating hardware. Internal pressure seals are vented on the ID and external pressure seals are vented on the OD.

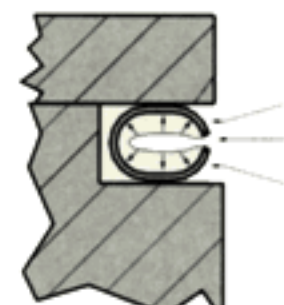
**70 BAR and higher:  
Self-energized**



## METAL 'C' SEALS

### Moontown standing for assurance of design, manufacturing and quality in advanced sealing technology

Pressure fluctuations and heat are constant concerns for designers of aircraft engines, valves, pressure transducers exhaust manifolds and fuel injectors. A combination of these two factors can result in premature failures or short seal life. Moontown C-ring seals can help overcome both heat and pressure pulsating sealing problems. Key to the seal's performance is the high spring back characteristic due to the C-shaped construction. These highly resilient seals can be used for internal, external and axial pressures under extreme conditions that preclude the use of gaskets made of organic materials. This uniquely fabricated seal configuration is capable of producing relatively high levels of spring back. The compression of the seal in a controlled groove or between two radial interfaces, produces a counter load, generating an effective sealing action that is ideal for these special applications.

#### Basic Design Characteristics

Moontown C-Ring seals will undergo plastic deformation when installed at the 20% recommended compression. These C-ring seals may be reusable in their original cavities or in cavities that are nearly the same depth as the original.

C-ring seals have much lower initial flange load requirements than O-rings. However, it is still high enough to provide effective smearing of the plating or coating used on the sealing surfaces. Deflection capability is excellent and it is normally assumed to be about half of the spring back, however, this is a function of the operating conditions and the required leakage rate.

#### Determining factors in seal selection

*In the seal selection process, the designer should always keep in mind the following rules.*

- There is a direct relationship between seal O.D. and free height
- Larger free height always provides a better performing, more consistent seal

The seal selection is a process of optimizing design limitations, size, available load, spring back, design requirements and cost

#### The most important factors in C-ring seal design are:

- Maximum pressure and direction
- Allowable leakage rate
- Extreme operating temperature
- Available flange load

#### High Performance Metallic Seal Types:

- Internal pressure
- External pressure
- Axial pressure

#### Deflection Capability

We define this as the ability to continue to seal as the flanges separate under pressure. This function is related to free height, material type, heat treatment and diameter. All things being equal, the larger the free height the more resilient the seal. More resilient seals allows for some tolerance on flanges which are out of flat and parallel.

#### Material Types, Platings and Coatings

Moontown C-ring seals can be made of almost any alloy that can be formed. However, because strength and temperature properties are the primary technical consideration, we produce our seals primarily from Alloy X750 or 718 materials. Other high temperature alloys are also available.

#### Moontown C-Ring Seals

Where very low leak rates are demanded, C-ring seals are plated or coated to provide a relatively soft surface which flow into the minor imperfections of the flanges at installation. Plating or coatings will not compensate for poor surface finishes on the mating hardware. The selection of plating or coating is based on the allowable leak rate, the viscosity (density) of the fluid, flange roughness and the application temperature.





### INTERNAL PRESSURE EXHIBIT A

SEAL		
C		A
Free Height	Tol.	OD Range
0,79	+/- 0,05	4,75 – 25,4
1,19	+/- 0,05	6,35 – 34,92
1,57	+/- 0,05	9,52 – 101,6
2,39	+/- 0,05	19,00 – 152,4
3,18	+/- 0,76	25,4 – 914,0
3,96	+/- 0,76	31,75 – 914,0
4,77	+/- 0,10	50,8 – 1220,0
6,35	+/- 0,10	101,6 – 3048,0
9,52	+/- 0,10	304,8 – 3048,0
12,7	+/- 0,13	610,0 – 3048,0

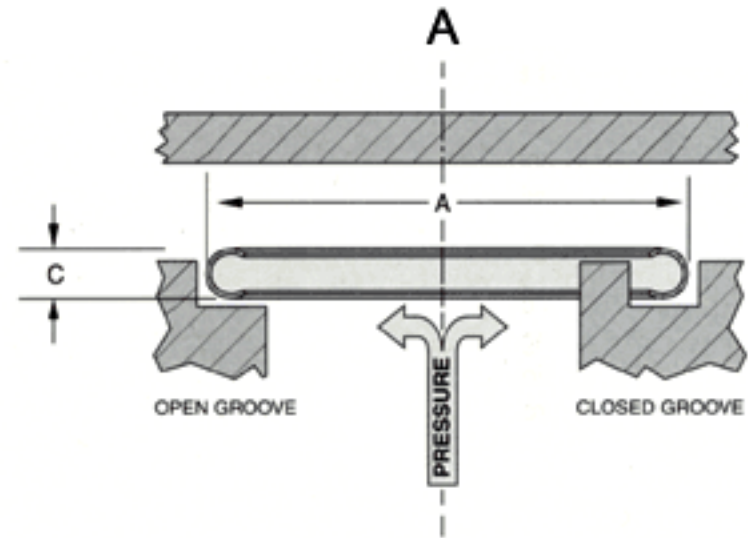

### EXTERNAL PRESSURE EXHIBIT B

SEAL		
C		A
Free Height	Tol.	ID Range
0,79	+/- 0,05	4,75 – 25,4
1,19	+/- 0,05	6,35 – 34,92
1,57	+/- 0,05	9,52 – 101,6
2,39	+/- 0,05	19,00 – 152,4
3,18	+/- 0,76	25,4 – 914,0
3,96	+/- 0,76	31,75 – 914,0
4,77	+/- 0,10	50,8 – 1220,0
6,35	+/- 0,10	101,6 – 3048,0
9,52	+/- 0,10	304,8 – 3048,0
12,7	+/- 0,13	610,0 – 3048,0

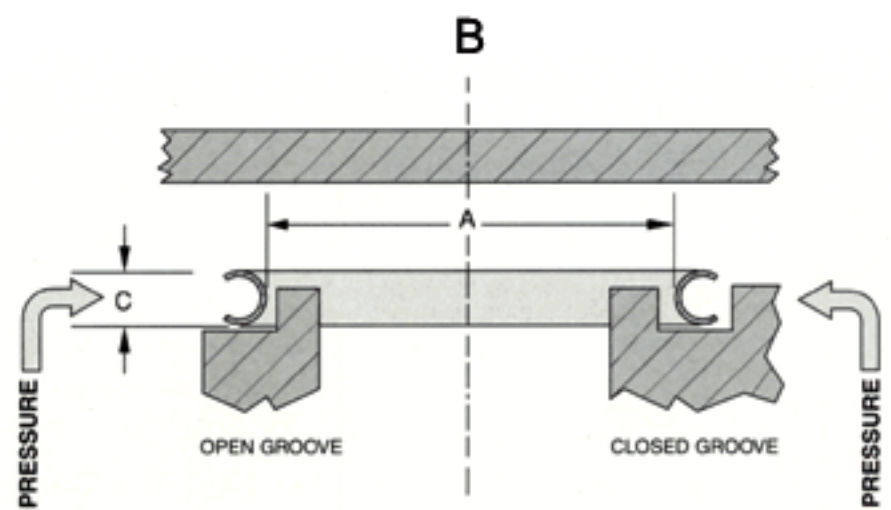

### AXIAL PRESSURE EXHIBIT C

SEAL	
C	A
Free height	OD Range
1,19	5,7 – 35,0
1,57	9,5 – 101,6
2,39	19,0 – 165,0
3,18	44,5 – 254,0
3,96	50,8 – 254,0
4,77	76,0 – 304,8
6,35	127,0 – 304,8

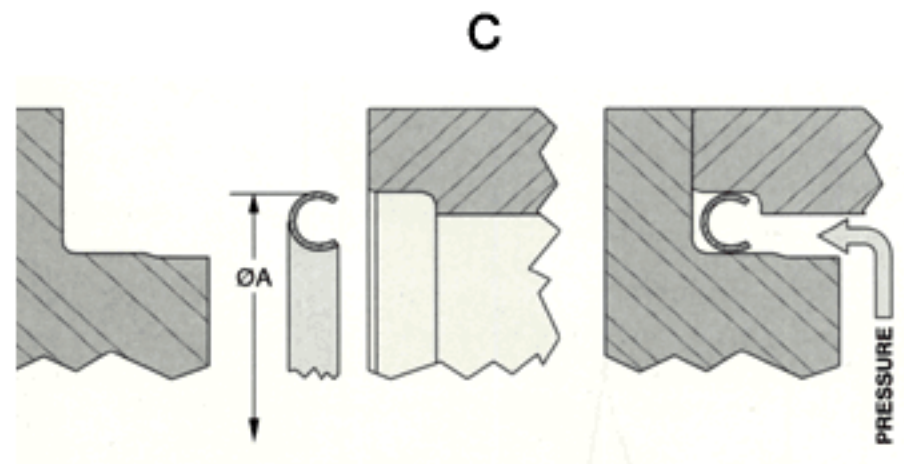



## METAL SPRING ENERGISED 'C' - SEALS

### Operating Conditions

The Moontown high performance seal has a temperature range from cryogenic to 1100 °C at pressures from 1x10<sup>-10</sup> Torr to 6900 BAR. These seals are normally not affected by corrosion, radiation or other adverse environmental conditions, provided the seal material is compatible with the medium.

### Seal Design Concept

The Moontown high performance seal is a self and pressure activated design. When the seal is compressed to a predetermined deflection, sealing stresses are generated by the resilient jacket and spring. Additional seal energization is achieved when system pressure is introduced, increasing seal loading. Unless otherwise engineered, the system pressure is applied to the open side of the seal.

### High Performance Metallic Seal Types:

- Internal Pressure
- External Pressure
- Axial Pressure

Moontown High Performance Seals use the compression of the mating hardware contact surfaces, and the system pressure or vacuum to provide an effective metal leakproof seal. The Moontown utilizes high temperature alloys for both jacket and springs. The proper combination of the base materials and surface coatings make it possible to seal practically any fluid at extreme temperatures or pressures without deterioration over extended periods of time.

**Moontown High Performance Seals provides superior performance for the most internal, external and axial applications such as:**

- Low Pressure - Ultra high vacuum
- High pressure to 6900 BAR
- Low temperature to -253°C
- High temperature to 1100°C

**Because of these capabilities, Moontown high performance seals are widely used in critical and demanding applications, including:**

- Missile and space systems
- Jet engines, controls, and instruments
- High temperature aircraft systems
- Nuclear reactor & waste containment systems
- Diesel engines
- Chemical, petro-chemical processing systems

### Dynamic Applications

Moontown high performance seals are ideal metallic seals for limited reciprocating and rotating motion, involving fluids and gasses with system pressures up to 2000 BAR cryogenic to high temperatures. The seal design and the unique forming and fabricating process provides a metal seal that maintains contact with the dynamic sealing surfaces. The energizing spring exerts uniform pressure on the jacket and keeps pre-set load on the seals. This unique design requires moderate sliding force, which can be adjusted to prevent seal deterioration and surface damage in dry or poorly lubricated applications.

### Design Considerations For Non-Circular Shapes

Moontown high performance seals are made in circular and non-circular configurations. The non-circular shapes in most cases require special tooling. There is also a very important relationship between the free height and the corner radii on these seals. Some of the non-circular shapes we are currently producing are as follows:

- Square
- Rectangular
- Oval
- Racetrack





**INTERNAL PRESSURE EXHIBIT A**

SEAL		
C		A
Free Height	Tol.	OD Range
1,57	+/- 0,05	12,7 – 101,6
2,39	+/- 0,05	25,4 – 152,4
3,18	+/- 0,076	31,75 – 91,4
3,96	+/- 0,076	31,75 – 91,4
4,77	+/- 0,10	50,8 – 121,9
6,35	+/- 0,10	101,6 – 304,8
9,52	+/- 0,10	304,8 – 304,8
12,7	+/- 0,13	610,0 – 304,8

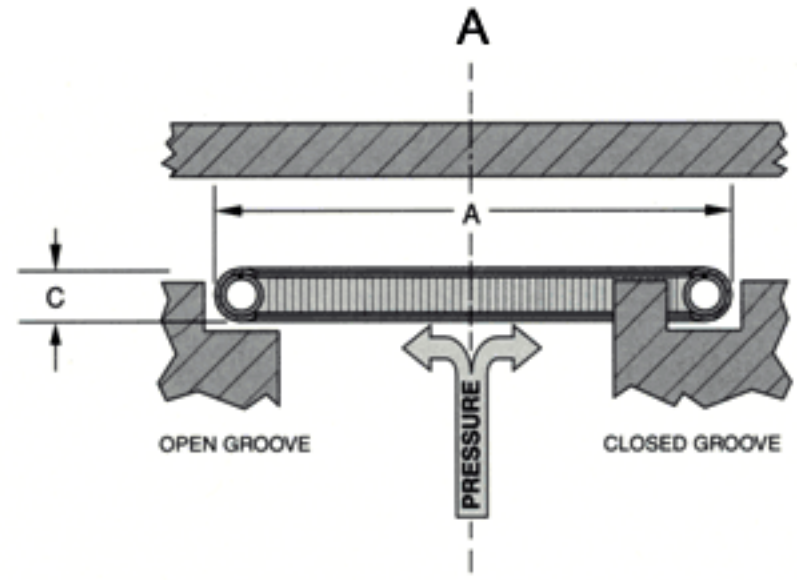

**EXTERNAL PRESSURE EXHIBIT B**

SEAL		
C		A
Free Height	Tol.	ID Range
1,57	+/- 0,05	12,7 – 101,6
2,39	+/- 0,05	25,4 – 152,4
3,18	+/- 0,076	25,4 – 91,4
3,96	+/- 0,076	31,75 – 91,4
4,79	+/- 0,10	50,8 – 121,9
6,35	+/- 0,10	101,6 – 304,8
9,52	+/- 0,10	304,8 – 304,8
12,7	+/- 0,13	610,0 – 304,8

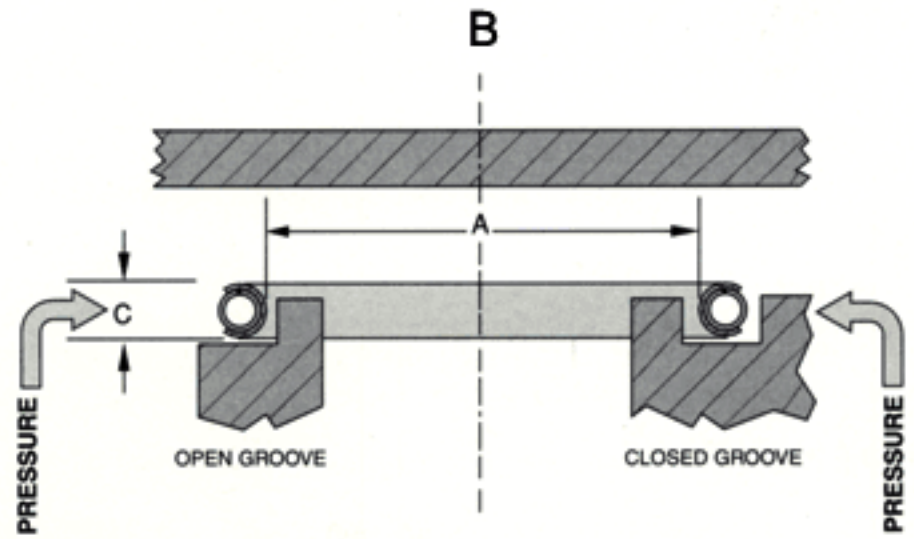

**AXIAL PRESSURE EXHIBIT C**

SEAL	
C	A
Free Height	OD Range
1,57	6,35 – 101,6
2,39	12,7 – 88,9
3,18	44,48 – 254,0
3,96	50,8 – 254,0
4,77	76,2 – 304,8
6,35	127,0 – 304,8

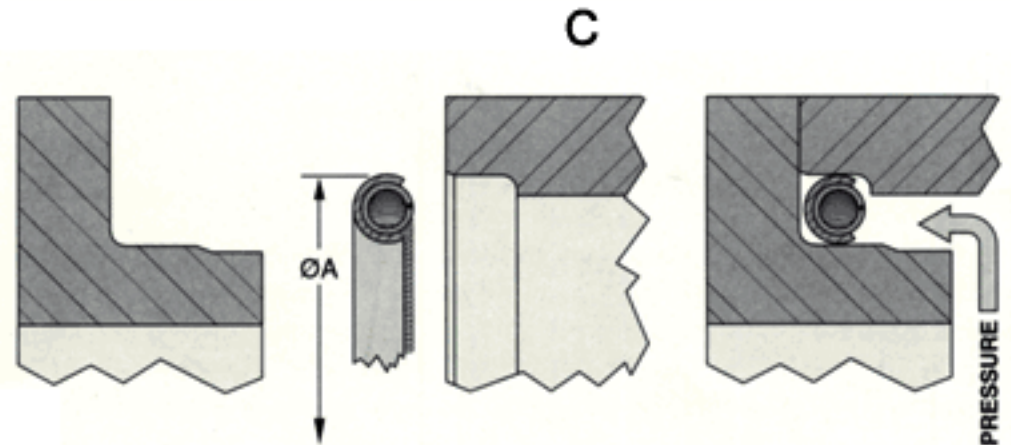





## METAL 'E' RING SEALS

### EXTERNAL PRESSURE

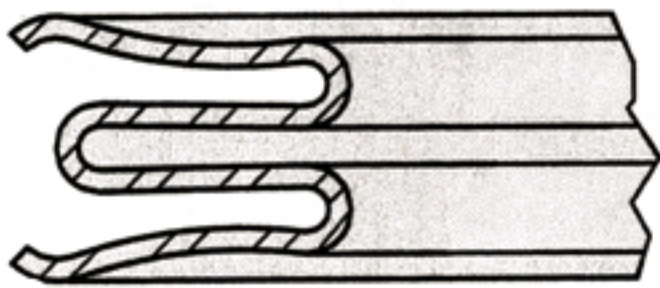

### INTERNAL PRESSURE

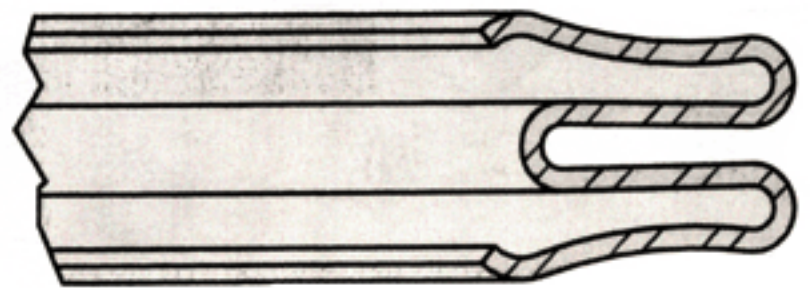

### INTRODUCTION

E-Rings (E cross section seals, convolution seals) are engineered to operate in applications that require light loading, flexibility and high temperature capability. E-Rings operate primarily within the elastic limits of the material. The superior flexibility or springback characteristics are important when used in cavities that experience large amounts of separation during normal operation. Applications include gas turbine engine housings, hot air ducting, exhaust manifold couplings and ball valve seat seals. This type of metallic seal exhibits very good fatigue resistance.

### PLATINGS & COATING

In static applications, platings and coatings offer only minor sealing enhancement due to the low force and resultant low sealing stress. In higher pressure applications, the stress can increase to allow the plating to smear into the cavity imperfections. In dynamic applications where the seal is subjected to fluctuating loads and cavity changes, the plating will work between the seal and the cavity improving sealing and also lubricating the two components. Cobalt-Molybdenum-Chromium-Silicon alloy coating can be applied to the seal surfaces to protect the seal from wear and fretting. Please consult ASE engineering for assistance with plating and coating selection for your specific application.

### LOAD & SPRINGBACK

E-Rings have excellent load deflection relationships up to the cavity depths shown in table 1. Seating loads shown in the tables are typical for the various cross sections compressed to the cavity depth shown. The compression load requirements are very low with higher springback compared to other metallic seal types. The load requirements will increase proportionally to system pressure, extending the springback capability in extreme conditions.

### MATERIALS

Inconel X-750 Specification AMS 5598, 5667  
Service Temperature up to 730°C

Inconel 718 Specification AMS 559, 5663  
Service Temperature up to 800°C

Waspaloy Specification AMS 5544  
Service Temperature 925°C

### HEAT TREATMENT

E Seals will be annealed, depending on complexity of form. Final form is solution annealed and age hardened (long cycle).





## METAL 'E' RING SEALS

### EXHIBIT A: INTERNAL PRESSURE

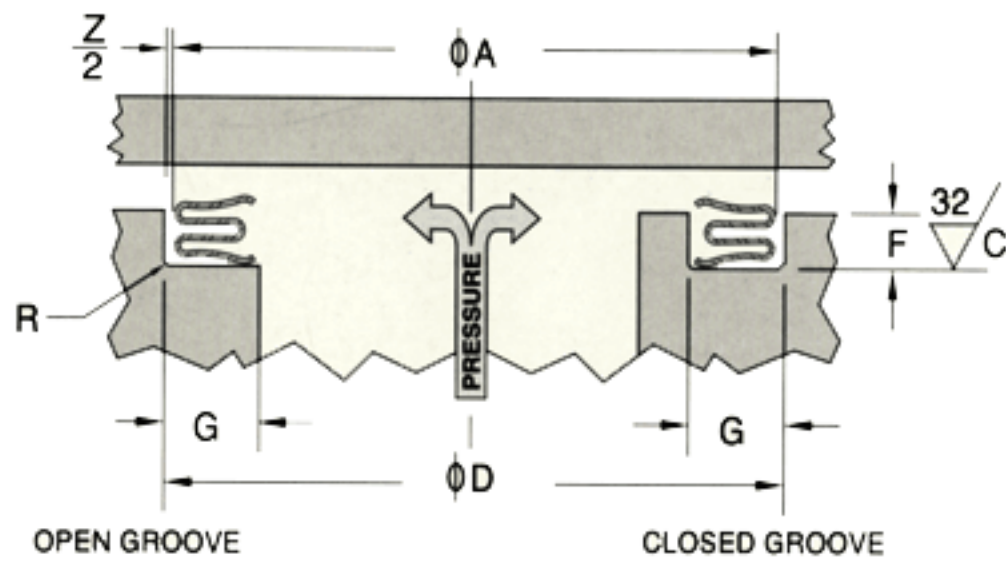
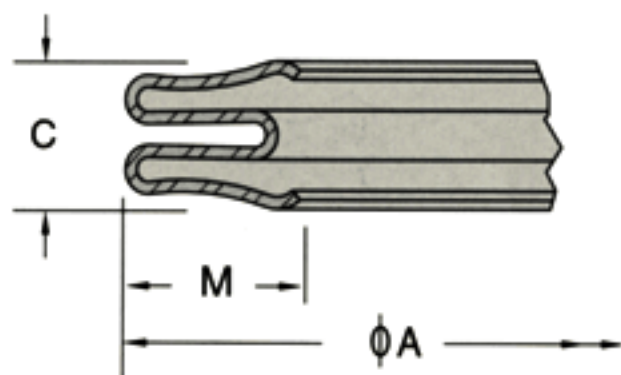

$$\text{ØA} = \text{D}_{\text{MAX}} + \text{Z} + 2\text{P}_{\text{MAX}}$$

ØA: TOLERANCE H11  
 D: MINIMUM GROOVE DIAMETER  
 Z: DIAMETRAL CLEARANCE FROM TABLE  
 P: MAXIMUM PLATING THICKNESS

SEAL DIMENSIONS (MM)				
C	A	Z	M	T
FREE HEIGHT	O.D. RANGE Tolerance h11	DIAMETRAL CLEARANCE	MAX. SEAL WIDTH	MATERIAL THICKNESS
1,91 +/- 0,076	38-305	0,076	1,68	0,152
2,49 +/- 0,076	57-457	0,076	2,11	0,203
2,74 +/- 0,127	57-457	0,076	3,68	0,229
2,74 +/- 0,076	50-457	0,076	2,31	0,254
3,35 +/- 0,076	63-812	0,127	3,02	0,203
3,55 +/- 0,127	63-812	0,127	4,90	0,305
3,55 +/- 0,127	57-812	0,127	3,10	0,381
5,54 +/- 0,127	90-1220	0,152	4,70	0,381
7,49 +/- 0,152	150-1524	0,203	6,81	0,508

GROOVE DIMENSIONS			
D	F	G <sub>3</sub>	R
GROOVE DIA. Tolerance H10	DEPTH MIN/MAX		
1	1,55/1,60	2,29	0,38
1	1,90/2,03	2,79	0,50
1	2,16/2,26	4,32	0,50
1	2,16/2,26	2,92	0,50
1	2,84/2,99	3,68	0,76
1	2,95/3,05	5,84	0,76
1	2,95/3,05	4,06	0,76
1	4,55/4,65	5,84	1,02
1	6,22/6,35	8,00	1,52

PERFORMANCE		
SEATING LOAD (Kg/mm) circumference	SPRINGBACK m/m	WORKING PRESSURE (BAR)
0,63	0,23	105
0,66	0,46	140
0,72	0,46	205
1,52	0,36	345
0,63	0,61	140
0,81	0,56	240
1,07	0,51	240
0,98	0,86	140
1,34	1,14	140

TOLERANCES		
NOMINAL DIAMETER RANGE	SEAL TOLERANCE (h11) +/- .000	CAVITY TOLERANCE (H10) +/- .000
6-10	0,076	0,051
10-18	0,102	0,076
18-30	0,130	0,084
30-50	0,160	0,100
50-80	0,190	0,120
80-120	0,220	0,140
120-180	0,250	0,160
180-250	0,290	0,185
250-315	0,320	0,210
315-400	0,360	0,230
400-500	0,400	0,250
500-760	0,500	0,300
760-1050	0,630	0,400
1050-1425	0,760	0,500
1425-1940	0,100	0,630
1940-2560	0,127	0,760

**NOTES:**

1. GROOVE DIAMETER AS SUPPLIED BY CUSTOMER
2. MATERIALS: ALLOY 718 PER AMS 5596, 5663 . WASPALOY PER AMS 5544
3. FOR APPLICATIONS ABOVE 315°C CONSULT MOONTOWN





# METAL 'E' RING SEALS

## EXHIBIT B: EXTERNAL PRESSURE

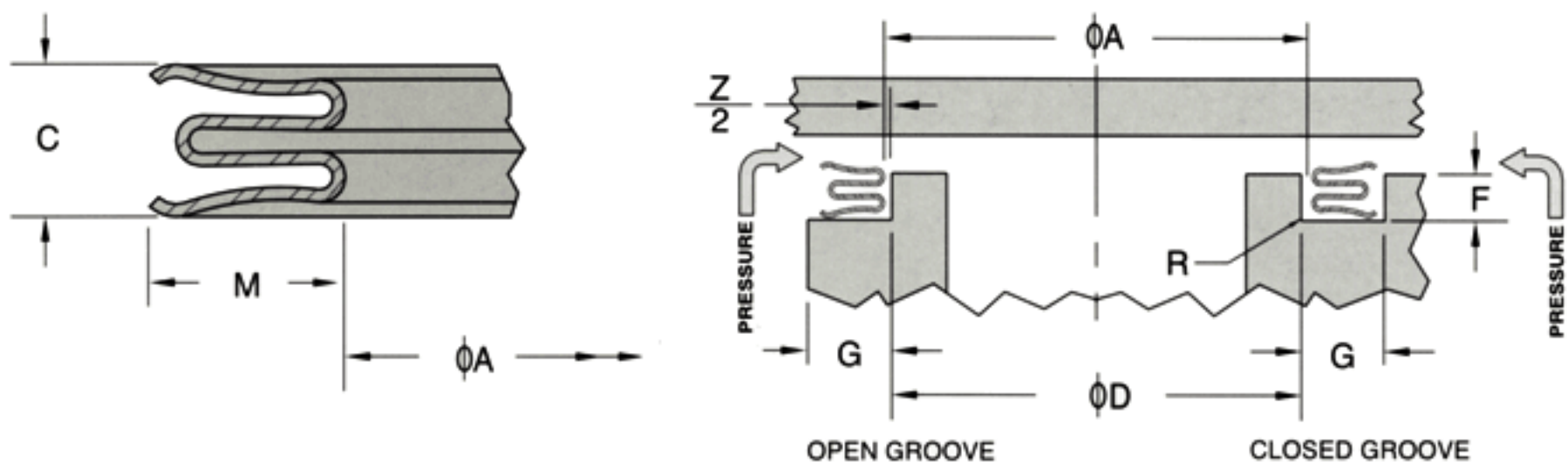

$$\phi A = \underset{\substack{\text{MIN} \\ \text{TOLERANCE } h11}}{D} - Z - \underset{\substack{\text{MAX} \\ \text{DIAMETRAL CLEARANCE FROM TABLE}}}{2P}$$

MAXIMUM PLATING THICKNESS

SEAL DIMENSIONS (MM)				
C	A	Z	M	T
FREE HEIGHT	O.D. RANGE Tolerance h11	DIAMETRICAL CLEARANCE	MAX. SEAL WIDTH	MATERIAL THICKNESS
1,91 +/- 0,076	38-305	0,076	1,68	0,152
2,49 +/- 0,076	57-457	0,076	2,11	0,203
2,74 +/- 0,127	57-457	0,076	3,68	0,229
2,74 +/- 0,076	50-457	0,076	2,31	0,254
3,35 +/- 0,076	63-812	0,127	3,02	0,203
3,55 +/- 0,127	63-812	0,127	4,90	0,305
3,55 +/- 0,127	57-812	0,127	3,10	0,381
5,54 +/- 0,127	90-1220	0,152	4,70	0,381
7,49 +/- 0,152	150-1524	0,203	6,81	0,508

GROOVE DIMENSIONS			
D	F	G	R
GROOVE DIA. Tolerance H10	DEPTH MIN/MAX	MINIMUM WIDTH	MAX CORNER RADIUS
▲	1,55/1,60	2,29	0,38
▲	1,90/2,03	2,79	0,50
▲	2,16/2,26	4,32	0,50
▲	2,16/2,26	2,92	0,50
▲	2,84/2,99	3,68	0,76
▲	2,95/3,05	5,84	0,76
▲	2,95/3,05	4,06	0,76
▲	4,55/4,65	5,84	1,02
▲	6,22/6,35	8,00	1,52

PERFORMANCE		
SEATING LOAD (Kg/mm) circumference	SPRINGBACK m/m	WORKING PRESSURE (BAR)
0,63	0,23	105
0,66	0,46	140
0,72	0,46	205
1,52	0,36	345
0,63	0,61	140
0,81	0,56	240
1,07	0,51	240
0,98	0,86	140
1,34	1,14	140

TOLERANCES		
NOMINAL DIAMETER RANGE	SEAL TOLERANCE (H11) + .000/-	CAVITY TOLERANCE (h10) +/- .000
6-10	0,09	0,058
10-18	0,110	0,070
18-30	0,130	0,084
30-50	0,160	0,100
50-80	0,190	0,120
80-120	0,220	0,140
120-180	0,250	0,160
180-250	0,290	0,185
250-315	0,320	0,210
315-400	0,360	0,230
400-500	0,400	0,250
500-760	0,500	0,300
760-1050	0,630	0,400
1050-1425	0,760	0,500
1425-1940	0,100	0,630
1940-2560	0,127	0,760

