



Integrated Monoleaf Suspension and Steer Axle System

Save up to 85 pounds with SOFTEK®

Trim weight and reduce maintenance with Hendrickson's SOFTEK® front mechanical suspension.

Hendrickson's SOFTEK combines the STEERTEK NXT axle and monoleaf spring technology to create a cutting-edge, weight-saving front suspension system. This complete system saves up to 85 pounds compared to a traditional two-leaf spring and I-beam axle system.

SOFTEK suspension system is designed for heavy-duty truck applications rated at 12,000- and 12,350-pound capacities. The advanced design captures characteristics of the traditional mechanical suspension while reducing weight to help increase payload capacity.

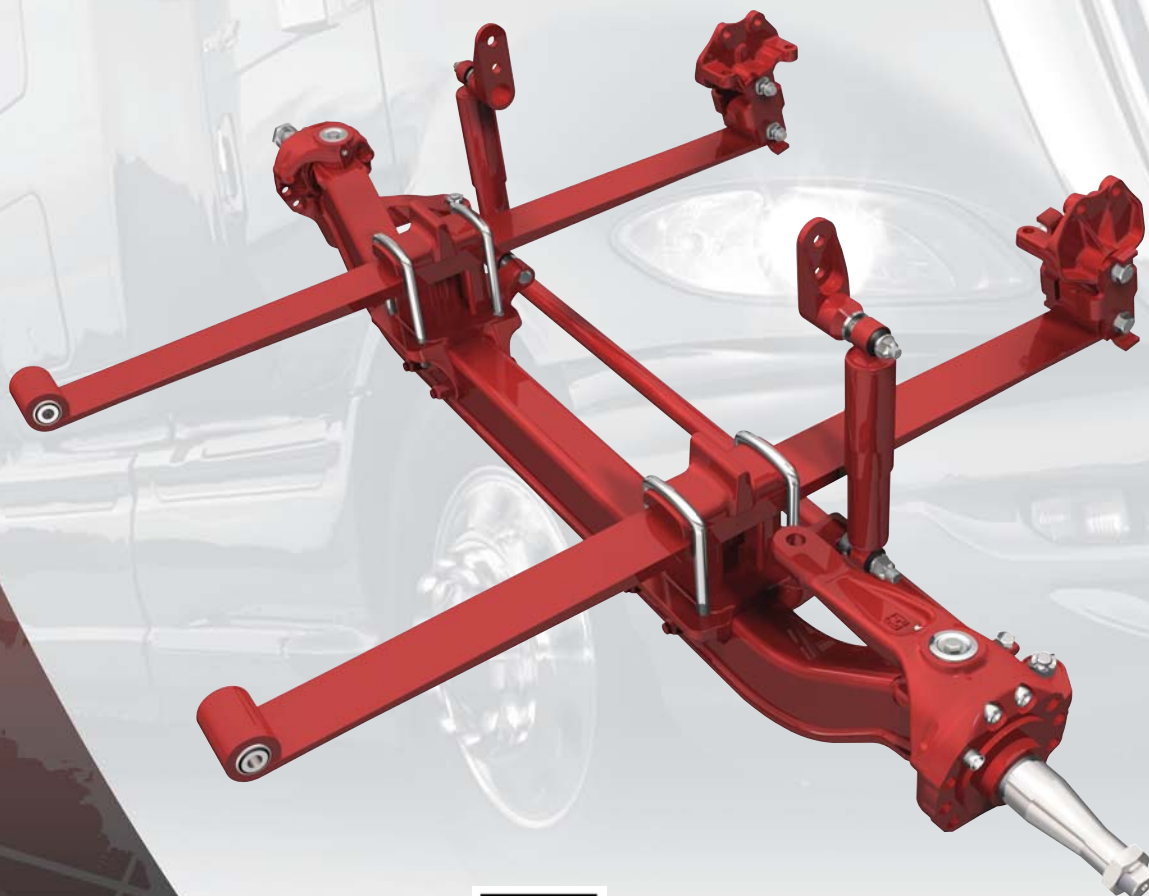

For more information, download
the free mobile app at gettag.mobi
and scan the tag to the left.

For additional information, call **630.910.2800** or
visit our web site at www.hendrickson-intl.com.



HENDRICKSON
The World Rides On Us®

SOFTEK® — Hendrickson's breakthrough design with integrated monoleaf spring and fabricated axle saves up to 85 pounds.

The world's leading supplier of heavy-duty springs and advanced suspension systems, Hendrickson drew on decades of engineering expertise to develop SOFTEK. Fleets and owner operators realize the benefits of weight savings and reduced maintenance that come with the advanced SOFTEK front suspension system.

Warranty

- STEERTEK NXT comes with a standard 10-year, 1 million mile limited warranty*

Monoleaf spring technology

- Reduces weight and eliminates inter-leaf friction

Soft ride monoleaf technology

- Utilizes sophisticated manufacturing techniques to help ensure long service life

Brake compatibility

- Compatible with drum or disc brakes
- Accepts both 5/8" and 3/4" brake hardware

Shackle redundancy

- Replaces the need for a second leaf thus reducing weight

STEERTEK NXT axle

- The box-shaped cross section resists horizontal, vertical and twisting forces more effectively than traditional I-beam axles
- Continuous beam architecture minimizes stress points for added durability
- Integrated axle seats to improve ground clearance, reduce part count, and simplify assembly

Steering and tie rod arms

- Integrated for increased strength and reduced weight

Rubber bushings

- Help reduce maintenance and noise
- Require no lubrication

Two-piece knuckle assembly

- Reduces the time required to service the kingpin bushings
- Premium kingpin bushings and seals provide enhanced protection from the elements to improve bushing life

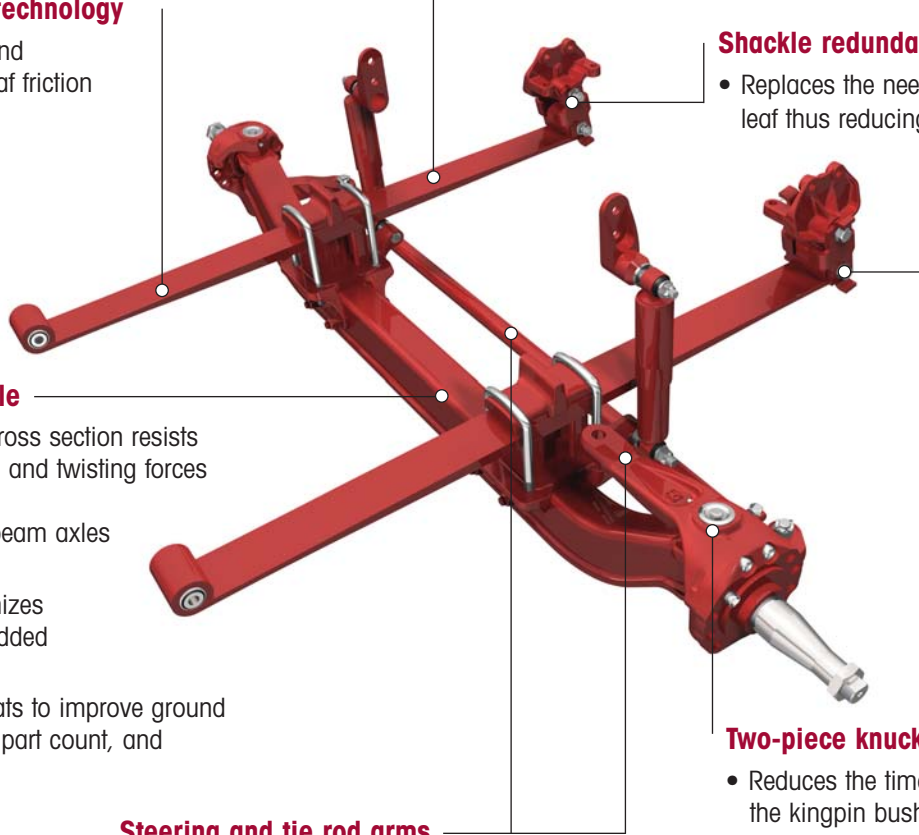

* 10-year, 1 million mile limited warranty covers certain structural components only. Warranty coverage applies to the axle beam, steering arm, knuckle assembly and kingpin when used in applications approved by Hendrickson and within the proper guidelines of the product. Warranty is not valid for bus, RV and coach applications and does not cover components experiencing normal wear. Contact Hendrickson for full warranty details and limitations.

www.hendrickson-intl.com

HENDRICKSON

Truck Commercial Vehicle Systems 1.866.755.5968
800 South Frontage Road 630.910.2800
Woodridge, IL 60517-4904 USA Fax 630.910.2899