

ELEVATION OF PREPARED
OPENING VIEWED FROM INSIDE

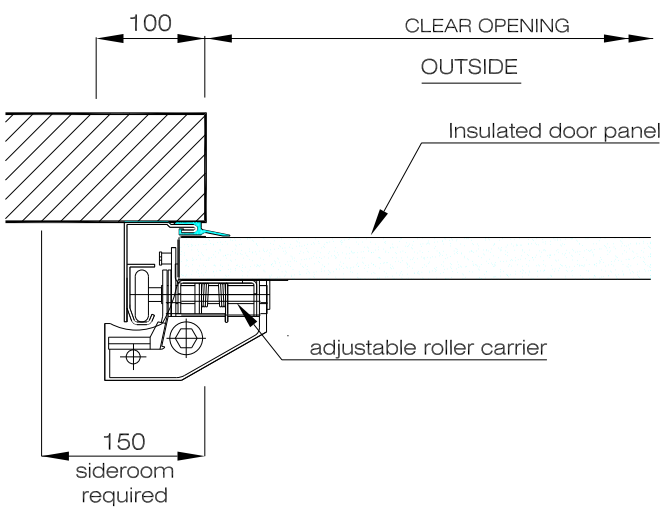

TYPICAL GUIDE FIXING TO STEEL JAMB

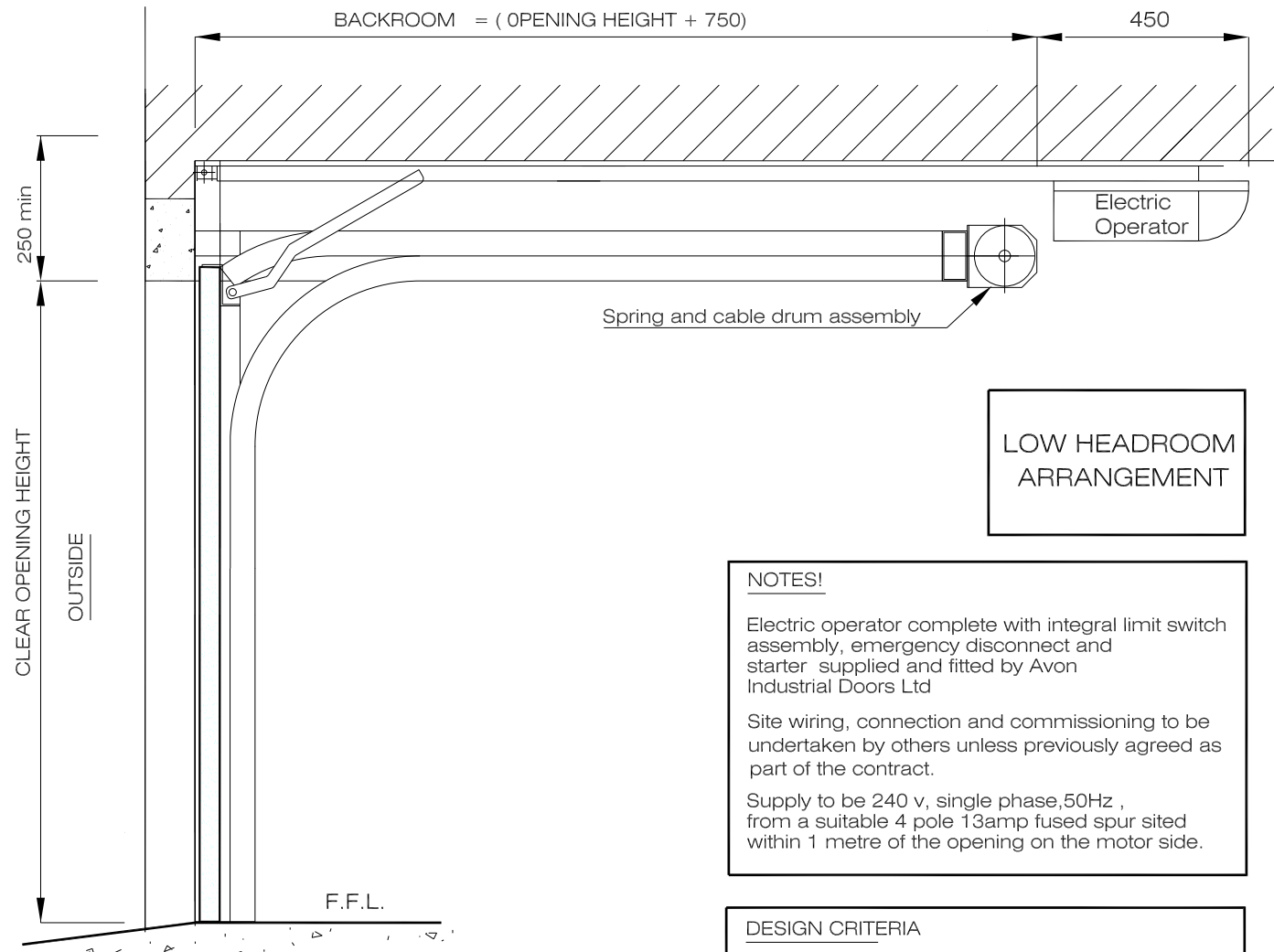

SECTION THROUGH OPENING

LOW HEADROOM
ARRANGEMENT

NOTES!

Electric operator complete with integral limit switch assembly, emergency disconnect and starter supplied and fitted by Avon Industrial Doors Ltd

Site wiring, connection and commissioning to be undertaken by others unless previously agreed as part of the contract.

Supply to be 240 v, single phase, 50Hz, from a suitable 4 pole 13amp fused spur sited within 1 metre of the opening on the motor side.

DESIGN CRITERIA

- 1) Maximum structural opening width 5000 mm
- 2) Maximum structural height 3000mm
- 3) Maximum door weight 300 kg
- 4) All fixing faces to be flush, plumb and clear of projections.
- 5) Design of the structural frame to be suitable to support the door and its fixings based on a design weight of 24 Kg / sq M.

THIS DRAWING MUST NOT BE SCALED.

