



Spare Parts

We also supply spare parts such as replacement cams, gears, paper knives and general running spares for all of the above mentioned machinery, as well as;

- Forming dies and cams for Uniplast I 60 A/B/C/D/BPK 0240A, Euromec, Strada, Baby/Super Rostoplast, 85a Super Robust, Aquarius RLM2 and RLM3 etc
- Cooking coils and bowls for Ter Braak TBK 750/1300, Hamac 145A and 155A and Solvomat
- Replacement conical rollers and sizing rollers for Hamac, Rose, Guiseley, Euromec batch rollers/rope sizers
- Wire / plastic belts for Hamac/Guiseley/Euromec/Klockner cooling tunnels
- Plastic belts for DT&G belt type chocolate coaters



After-Sales Services



A.M.P Rose technicians are available to travel world-wide for the servicing, installation and commissioning of candy and chocolate equipment.

Services provided;

- Equipment installation and commissioning
- Machine break-down service
- Training for operators and maintenance staff
- Annual maintenance contracts including parts and labour
- Specialist confectioners for trouble-shooting or recipe formulation

Redundant Assets



The Company also purchases Client's redundant machinery. Whether it is an outright purchase, a trade-in against new or rebuilt machinery, or a sale on the Client's behalf, with our considerable industry contacts, the Customer can be certain of the best deal possible for their redundant equipment.

Where a large number of machines or production lines are involved, A.M.P Rose can arrange for disposal via auction, which can be done either on-site or over the internet. This can also include the safe removal of the equipment from site and the onward shipping to the buyers.

As industry experts, we can also provide current valuations of clients assets, for disposal, financial or insurance purposes.

Website



Our website is regularly updated and includes complete listings and photos of all our current stock of used machinery. Please visit www.amp-rose.com

A.M.P-Rose



REBUILT MACHINERY



A.M.P-Rose

Heapham Road North, Gainsborough,
Lincolnshire. DN21 1QU. England
Tel: +44 (0) 1427 611969
Fax: +44 (0) 1427 616854
e-mail: sales@amp-rose.com
website: www.amp-rose.com

Represented by;

A.M.P-Rose

Your partner in the confectionery industry



REBUILT MACHINERY

For more than 30 years the A.M.P-Rose name has been synonymous with the supply of the highest quality rebuilt machines. The Company has an enviable reputation and a world-wide Blue Chip customer base.

Our policy is to offer our customers the price and delivery advantages of buying used equipment with the risk removed and the reassurances of the highest standards of engineering excellence.

Our technicians are experienced with many different brands of processing and packaging machines, which allows us to supply almost any machine required in the candy and chocolate manufacturing processes.

The work undertaken to a fully rebuilt machine includes the following;

- Complete strip down to the bare frame
- Steam clean and spray paint
- Every component inspected and all damaged or faulty ones replaced or repaired
- Design and manufacture of new size-change parts (if required)
- Design and manufacture of new style-change parts (if required)
- Re-assembly by skilled, experienced technicians
- Completely new electrical wiring throughout
- New electrical panel and components
- Provision of guarding to meet current Health & Safety standards
- Machine set-up and test-run using clients products and wrapping materials
- Supply of machine operator manuals and electrical wiring diagrams
- Optional 'CE' documentation and accreditation
- Optional installation, commissioning and training services

A rebuilt machine supplied by A.M.P Rose carries a comprehensive 12 months parts and labour guarantee.

Used machines can also be supplied which are reconditioned to a lesser standard – offering the advantage of a lower investment and a quicker lead-time. Machines can be tailored to suit the customers' budget and specific needs.

Our Facilities

The Company employs over 100 skilled personnel in a modern and well-equipped manufacturing facility, which houses the following facilities;

- Sales, administration, accounts, export and shipping offices
- 2D and 3D CAD/CAM facility including solid modelling and advanced machine design software
- Purchasing and planning departments using modern manufacturing software
- Component manufacturing using conventional and CNC machine tools
- Spray painting and component finishing facilities
- Spare parts and after-sales service departments
- Machine assembly departments for both processing and packaging machines
- Crate manufacturing, packing and dispatch departments

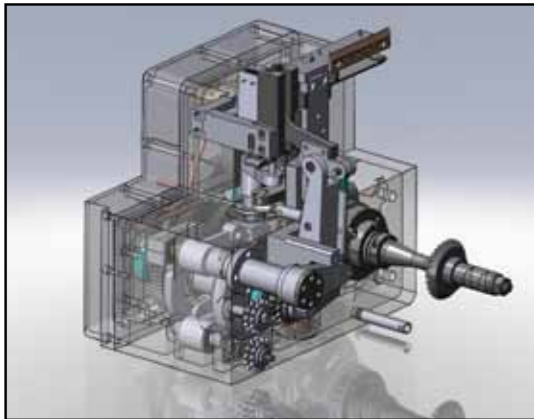

- Hard candy/toffee/chew/jelly cooking systems
- Candy forming and processing lines
- Cut & wrap machines
- Pre-formed sweet wrappers
- Chocolate wrapping
- Biscuit wrapping
- Chocolate tempering/coating
- Roll/stick wrapping machines
- Chocolate moulding
- Carton erectors/overwrappers
- Horizontal/Vertical FFS
- Chocolate/sugar coating systems
- Bar forming lines



Examples of a servo upgrade to a high speed pillow pack machine

Machine Up-Grades

As food manufacturing companies strive to reduce cost, today's Production Managers demand that packaging machines have higher speeds, greater efficiency, and more automation.

It is not un-common to find machinery in food factories that are more than 20 years old. Such machines may still be operational but often they do not meet current requirements, not only in terms of output and efficiency, but also in terms of operator safety.

Such improvements can be undertaken either at the Customer's site or at the A.M.P Rose factory, depending on the complexity of the changes.

Typical improvements to such machines include;

- Inspection and servicing
- Supply or up-grading of machine guards
- Electrical re-wiring
- Retro-fitting of PLC's and 'Human-Machine Interface units' (HMI's)
- Replacement of mechanical units with Servo or other types of drives
- Modifications to suit new wrapping materials – for cost or marketing reasons
- Re-design of mechanisms to increase output/efficiency
- Addition of robotic feeding systems
- 'CE' marking for electrical and mechanical safety



Product Size & Style Changes

A.M.P Rose regularly supplies size and style change sets for many different types of confectionery and chocolate wrapping machines. Such machines include

SIG: DSR / DST / DSH / DST / DSN / C / CK / CK-R / CL / CL-R

SAPAL: TD / BB / ZRM / Bi-b / Bn-e / BN-p / BN-k / PRLP

RASCH: RK / RU / RUE / RG / RGE / RHE

ROSE THEEGARTEN: UI / UI-EFC / UI-FI / FWT / HI / HI-FI / A2-DB / A3

AUTOWRAPPERS: RH / SUPER 2000 / VERSAFLOW / CBR

OTTO HANSEL: X 8000 series / SPEEDY 7210/7215

GD: 2500 / 5000 B and UNI / 2650 / 2120R / 4600 / 2160B / 4000S

NAGEMA: EU 3 / EU4 / EU7 / EU8 / EL9 / EW5 / EW7

CARLE & MONTANARI: CMY 55 / CMY 800 / CMY 871

ROSE 110 / 112 and **SIG** GS / GRT biscuit wrappers

ROSE FORGROVE TEA & ICE CREAM CARTON ERECTORS and RAZOR BLADE WRAPPING MACHINES

ALL ROSE & FORGROVE chocolate and candy wrapping machines



- Rose • SIG • Sapal • Rasch • Theegarten • Carle & Montanari • Aquarius • Hamac Hansella • Pactec • Ter Braak • Otto Hansel • DT&G
- Ruffinatti • ACMA GD • Marden Edwards • YPP • Nagema • Baker Perkins • Klockner • Autowrappers • Bosch • Forgrove • BCH • Loesch
- Buhler • Sollich • Nielsen • Dumoulin • Tevopharm • Aasted • Fima • Euromec